



## **Operational flexibility of combined heat and power plant with steam extraction regulation**

Downloaded from: <https://research.chalmers.se>, 2026-04-06 21:56 UTC

Citation for the original published paper (version of record):

Beiron, J., Mocholí Montañés, R., Normann, F. (2019). Operational flexibility of combined heat and power plant with steam extraction regulation. *Energy Proceedings*, 5

N.B. When citing this work, cite the original published paper.

# OPERATIONAL FLEXIBILITY OF COMBINED HEAT AND POWER PLANT WITH STEAM EXTRACTION REGULATION

Johanna Beiron<sup>1\*</sup>, Rubén M. Montaños<sup>1</sup>, Fredrik Normann<sup>1</sup>

1 Department of Space, Earth and Environment, Chalmers University of Technology, S-412 96 Göteborg, Sweden  
\*(Corresponding Author, beiron@chalmers.se)

## ABSTRACT

This paper evaluates the potential for flexible operation of combined heat and power plants, using previously validated steady-state and dynamic process models. The models compute the change in power and heat generation, as well as the response times of steam turbine extraction regulation. It is found that for small-to-medium sized plants, steam bypass could be a promising solution for regulation of power output, also in combination with boiler load changes. Rise times for load reductions by valve opening are within 30 s, independent of the extracted flow, and steam extractions/bypass can lead to power output reductions of up to 30% of rated power. However, plant specific design aspect may limit the achievable magnitude of load changes and must be considered.

**Keywords:** Combined Heat and Power, Operational Flexibility, District Heating, Steam Extraction, Dynamic Modeling

## NONMENCLATURE

### Abbreviations

CHP	Combined Heat and Power
DH	District Heating
TES	Thermal Energy Storage

## 1. INTRODUCTION

The demand for operational flexibility in thermal power plants is expected to increase as the share of non-dispatchable renewable energy sources, for example wind power, grows in power systems. The ability to vary the power generation on timescales from seconds to

seasons presents business opportunities for power plants and is beneficial for balancing of the energy system.

In thermal power plants, the power output is commonly varied by changing the boiler load, see e.g. [1,2]. However, ramping of boilers to cover short-term fluctuations is associated with thermal stress and lifetime reduction of components, which may cause increased maintenance costs. To avoid ramping of the boiler, power generation may instead be varied by regulation of the steam flow to and from the steam turbine. Steam extraction regulation has previously been studied for large-scale coal condensing plants, in combination with internal thermal energy storages (TES) [3–5]. A TES avoids the thermodynamic losses that would result from condensing the extracted steam with cooling water. However, for combined heat and power (CHP) plants, TES implementation might not be necessary (although possible, as studied in [6]), since the extracted steam can instead be cooled by the district heating (DH) flow, temporarily causing variations in the DH generation, which can be buffered by the DH system.

The aim of this paper is to determine: 1) the potential and operational limitations for using steam extractions to manage operational flexibility of small-to-medium size CHP plants, and 2) the related impact on DH delivery.

## 2. METHOD

### 2.1 Reference plant description

A Swedish 48 MW<sub>el</sub> waste-fired CHP plant is used as a reference in this work. The plant configuration is shown in Figure 1, with emphasis on the steam cycle. The plant has extraction and backpressure condensers for district heating generation (Cond 1-2). The plant is currently

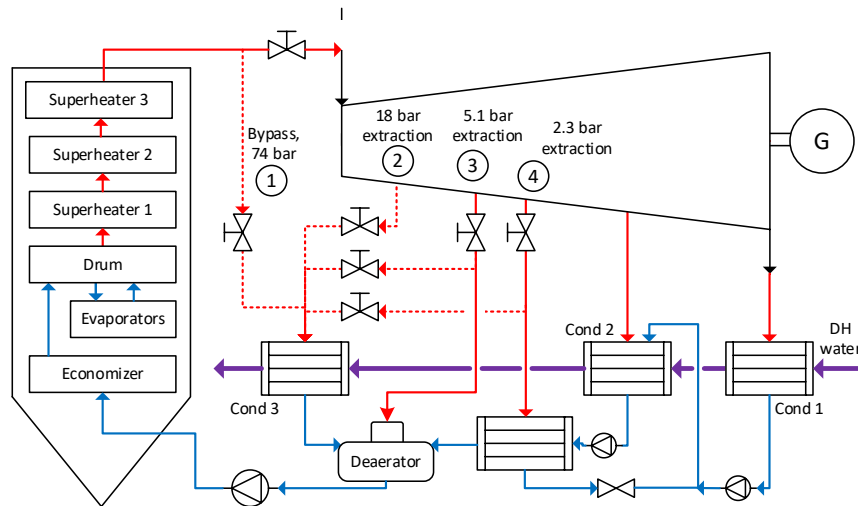

Fig 1 Illustration of the reference plant configuration, with extraction points currently in use (3,4; solid lines) and potential extraction points (1,2; dashed lines).

using steam extractions for low-pressure feedwater heating and deaeration. A non-operational extraction point also exists at a higher pressure. Furthermore, there is a turbine bypass connected to a third condenser (Cond 3, not meant to be in operation).

## 2.2 Process modifications

This study considers potential process modifications to the reference plant. The options evaluated represent four possible steam extraction regulating operations, that are either in use (solid lines in Fig 1) or could be implemented with slight retrofits to the plant (dashed lines). All new steam extractions are condensed in condenser 3, to produce DH, with condensate return to the deaerator tank. The operational steam regulation options and the design extraction pressures considered are:

1. Turbine bypass point (74 bar)
2. Turbine high-pressure point (18 bar)
3. Deaerator extraction point (5.1 bar)
4. Feedwater heater extraction point (2.3 bar)

## 2.3 Modeling

Models of the reference plant are implemented in the steady-state and dynamic modeling environments Epsilon Professional and Dymola/Modelica, respectively. The models are developed based on process and design data from the reference plant, and are validated for stationary and transient operation, see our previous work, Beiron et al. [7], for a thorough description of the dynamic model including model validation. The steam extraction regulations are implemented as control valves

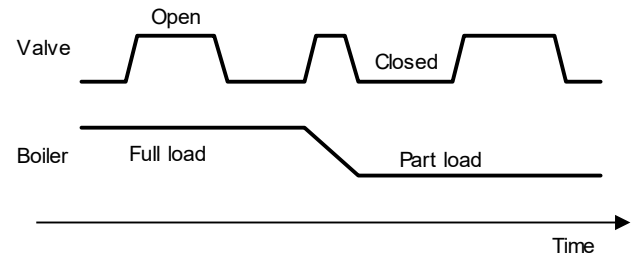

Fig 2 Dynamic simulation cases with valve opening/closing at boiler full and part load.

with mass flow regulators. The regulatory control layer is modified to keep the pressure and temperature of the extracted steam within the design range of condenser 3.

## 2.4 Simulations

The models developed simulate the impact of steam extraction regulation on plant performance. The stationary model simulations are run for a fixed extraction pressure and boiler load, while the mass flow of extracted steam is varied within a relevant range. The resulting absolute change in power and DH generation is computed for each extraction point.

The dynamic model simulations provide the response time for each operational action. The simulations are performed as 10-20 s ramps for the cases listed below and visualized in Figure 2.

- A. Opening of steam extraction valve, for reduction of the steam turbine load, at full or 87% of boiler load.
- B. Closing of steam extraction to deaerator or feedwater heater, to increase steam turbine load, at boiler full load.

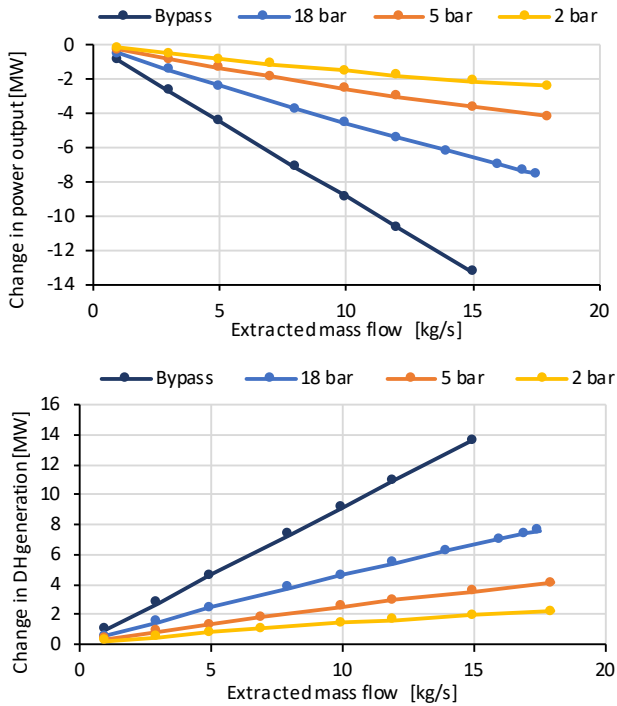

Fig 3 Change in power and DH generation depending on steam extraction flow at four extraction pressures.

- C. Combined opening of steam extraction valve and boiler load reduction from 100 to 87% of full load, for a faster steam turbine load reduction compared to that achieved by boiler load reduction only.

The target extracted steam mass flow sets the valve opening and is adapted to suit each case. A sensitivity analysis examines how the size of extracted flow impacts the response time. The response variables considered are: generator power output, DH generation and DH supply temperature. For each response variable, the rise time is calculated. The rise time is defined as the time required to go from 10% to 90% of the steady-state response.

### 3. RESULTS AND DISCUSSION

The steady-state results of change in power and DH generation when increasing the steam extraction flow at the four extraction points are presented in Figure 3. The changes in power and DH are of opposite sign and comparable magnitude, indicating that the total plant efficiency remains unaffected. Obviously, the power output is most effected by the extraction of high-pressure steam, close to 14 MW (30% of rated power) for a 15 kg/s bypass; as this steam has the highest enthalpy. The 18-bar extraction also yields a noticeable power reduction, up to 8 MW. The impact of low-pressure (2.3

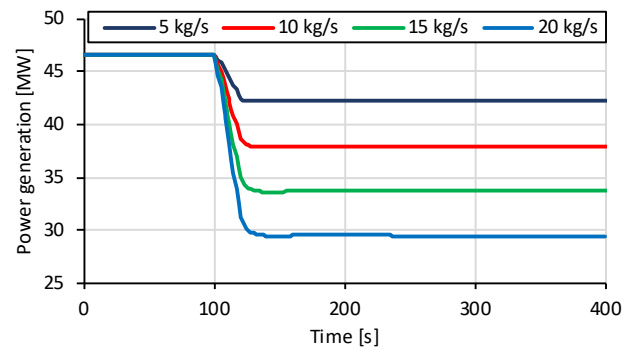

Fig 4 Dynamic responses for power generation when various mass flows of steam are bypassed the turbine.

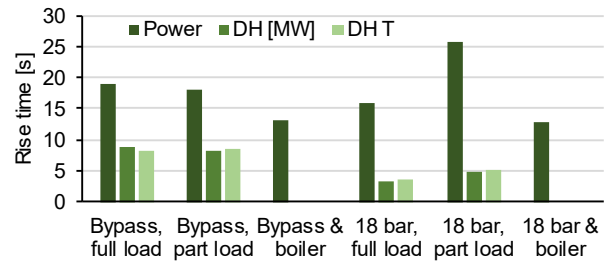

Fig 5 Response variable rise times for bypass and 18 bar extraction valve openings, with Cases A and C. DH bars for Case C are omitted because rise time is not considered a suitable measure for the inverse responses observed.

bar steam) extraction is marginal, < 3 MW. The DH supply temperature is increased in all cases, with a maximum  $\Delta T$  of 5°C for a 20 kg/s bypass.

For the dynamic simulations, power output responses for bypass extractions (Case A, 100% load) of varying mass flows are plotted in Figure 4. The valve opening starts at time = 100 s. The response times are of similar magnitude (rise times around 16-19 s) independent of the mass flow of steam extracted. The rise times for Case A (full and part load) and Case C are presented in Figure 5, for the three response variables, which are all within 30 s. In comparison, rise times for boiler load changes of similar magnitude as achieved by the extraction regulations are around 400 s. The practical implications of these results are that Case A can be efficiently used to accomplish variability in power generation on short timescales, for example applied to frequency response markets, in which activation times are commonly within 2-3 minutes. Case C can increase the plant ramp rate for load changes that last for longer periods of time, for instance related to the hourly day-ahead power market.

Closing the valves for the deaerator and feedwater heater extractions (Case B) cause inverse dynamic responses, with a temporary increase in steam turbine

power that over time changes to a reduction in steady-state power output. For example, reducing the deaerator steam flow from 2 to 0.7 kg/s leads to an initial power increase that is maintained above 2 MW for around 25 minutes; thereafter decreasing and settling at a 3 MW power reduction. The load reduction is due to the lowered efficiency resulting from less steam being available for feedwater preheating. Thus, Case B could be applicable for steam turbine load increases, although limited to minute-timescales.

For the 48 MW<sub>el</sub> CHP plant studied, the opening of extraction valves is limited by feedwater conditions. The feedwater is only slightly subcooled in the deaerator – less than 1°C at design conditions. As steam is extracted, the deaerator steam pressure is reduced as the flow through the turbine is lowered, and threatens to sink below the saturation pressure of the water. This is a potential cavitation problem for the feedwater pump and, thus, puts an upper limit on the allowable extraction flows. Larger plants equipped with multiple feedwater preheating stages might avoid this problem. This result shows that plant size and design should be considered when evaluating operational retrofits and actions, and highlights the importance of closed-loop power plant simulations for this purpose.

The CHP plant is a part of a DH network that requires stable delivery of DH from the plant. The variations in DH and DH supply temperature caused by steam extraction regulation must therefore be kept within limits. The observed  $\Delta T$  for steam bypass are below 5°C, but the temperature change also depends on the DH flow, which in turn is related to the size and operation of the DH network. System studies are needed to further analyze these dependencies. To manage variations in DH generation that do not follow the demand profile, a TES (e.g. a hot water accumulation tank) could be installed in the DH network, where surplus heat can be stored for later use [6].

From a system point of view, having the ability to increase DH generation in a base-load CHP plant using steam extractions, could reduce the need for expensive peak units during high-demand periods and lead to lower operating costs for the DH system.

#### 4. CONCLUSION

This paper considers the potential of power output variability by regulation of steam extractions in a CHP plant of small-to-medium size. In summary, high-pressure steam extractions could yield changes in power generation of a magnitude significant to power markets, including balancing markets and ancillary services. In this

case, up to 14 MW (30% of rated power) may be reduced within 30 seconds, which is significantly faster than a corresponding boiler load change. Flexible operation of steam extractions could, thus, be an effective way of providing variation management to the power system with only slight retrofits to the process and/or modifications to the plant control system.

#### ACKNOWLEDGEMENT

This project is financed by the Swedish Energy Agency, Energiforsk – The Swedish Energy Research Centre and Göteborg Energi AB.

#### REFERENCES

- [1] Korpela T, Kaivosoja J, Majanne Y, Laakkonen L, Nurmoranta M, Viikko M. Utilization of District Heating Networks to Provide Flexibility in CHP Production. *Energy Procedia* 2017;116:310–9. doi:10.1016/j.egypro.2017.05.077.
- [2] Kahlert S, Spliethoff H. Investigation of Different Operation Strategies to Provide Balance Energy With an Industrial Combined Heat and Power Plant Using Dynamic Simulation. *J Eng Gas Turbines Power* 2016;139:1–8. doi:10.1115/1.4034184.
- [3] Zhao Y, Liu M, Wang C, Li X, Chong D, Yan J. Increasing operational flexibility of supercritical coal-fired power plants by regulating thermal system configuration during transient processes. *Appl Energy* 2018;228:2375–86. doi:https://doi.org/10.1016/j.apenergy.2018.07.070.
- [4] Zhao Y, Wang C, Liu M, Chong D, Yan J. Improving operational flexibility by regulating extraction steam of high-pressure heaters on a 660 MW supercritical coal-fired power plant: A dynamic simulation. *Appl Energy* 2018;212:1295–309. doi:10.1016/j.apenergy.2018.01.017.
- [5] Richter M, Oeljeklaus G, Görner K. Improving the load flexibility of coal-fired power plants by the integration of a thermal energy storage. *Appl Energy* 2019;236:607–21. doi:https://doi.org/10.1016/j.apenergy.2018.11.099.
- [6] Wang W, Sun Y, Jing S, Zhang W, Cui C. Improved Boiler-Turbine Coordinated Control of CHP Units with Heat Accumulators by Introducing Heat Source Regulation. *Energies* 2018;11:2815. doi:10.3390/en11102815.
- [7] Beiron J, Montañés RM, Normann F, Johnsson F. Dynamic modeling for assessment of steam cycle operation in waste-fired combined heat and power plants. *Energy Convers Manag* 2019;198:111926. doi:10.1016/j.enconman.2019.111926.