

TECHNICAL REPORT

Modelling of heat pumps, controller for space and water heating

SINDHU KANYA NALINI RAMAKRISHNA, TORBJÖRN
THIRINGER



Department of Electrical Engineering
Chalmers University of Technology
Gothenburg, Sweden

Modelling of heat pumps, controller for space and water heating

SINDHU KANYA NALINI RAMAKRISHNA, TORBJÖRN THIRINGER

© SINDHU KANYA NALINI RAMAKRISHNA, TORBJÖRN THIRINGER 2024
All rights reserved.

Technical Report No. 2024:1
Department of Electrical Engineering

Division of Electric Power Engineering
Chalmers University of Technology
SE-412 96 Gothenburg, Sweden
www.chalmers.se

Contents

1	Introduction	1
2	Heat pump	3
2.1	Actual vapour compression heat pump cycle	4
	Pressure-enthalpy diagram	4
	Thermodynamic analysis of the components in a heat pump . .	6
2.2	Compressors	8
2.3	Model for refrigerant's mass flow rate in scroll compressors . .	8
2.4	Performance indicator of heat pumps	9
2.5	Vapour injection in scroll compressors	10
2.6	Procedure for calculating the COP of a heat pump using the thermodynamic tables	11
	Vapour compression heat pump cycle without vapour injection	11
	Vapour compression heat pump cycle with vapour injection . .	11
3	Controller for space and water heating	15
3.1	Thermal model of a house	15
3.2	Controller design for space heating	16
3.3	Stratified layer model of domestic hot water tank	19
3.4	Controller design for water heating	19
3.5	Controller design for providing space and water heating	22

CHAPTER 1

Introduction

An increase in the share of electricity production from intermittent sources of energy and reduction in the share of fossil fuel based synchronous generators, creates a demand for flexible resources. One such flexible resource is a heating system equipped with a heat pump.

In Sweden, a majority of the electric energy consumption takes place in the residential and service sector. Furthermore in the residential sector, the per capita consumption in single family houses are higher compared to multi family dwellings. Also, around half of the consumption in single family houses is from heating systems and these systems are generally equipped with heat pumps. This indicates the potential of heating systems to act as flexible resources. The heat pumps used in single family houses provide both space and water heating, with a priority set for water heating.

To use the heating system as a flexible load, it is important to know the electric power consumption by the heat pump while operating at different conditions. Furthermore, flexibility also depends on the control action of space and water heating. Thus, with this background, the main aim of this report is to, describe the detailed modelling of a heat pump, controller design for space and water heating.

CHAPTER 2

Heat pump

A heat pump is a device used for space heating, cooling and water heating applications. In case of heating applications, the heat pump transfers the heat from a low temperature source to a high temperature sink. To enable the heat transfer between the source and sink, the heat pump must be powered by an external source like electricity.

The main components in a heat pump are shown in figure 2.1. They are also listed below:

- Evaporator
- Compressor
- Condenser
- Expansion valve

The operation of a heat pump is based on an actual vapour compression heat pump cycle. The vapour compression heat pump cycle consists of four processes and they are as listed below:

- Heat absorption by the refrigerant in the evaporator
- Compression of the refrigerant in the compressor
- Heat rejection by the refrigerant in the condenser

- Throttling/expansion (pressure drop) of the refrigerant in the expansion valve

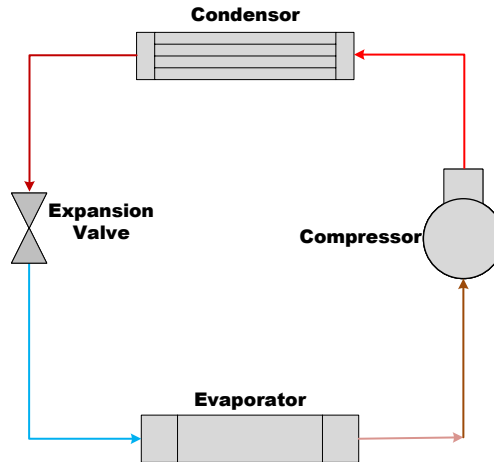

Figure 2.1: Main components in a heat pump [1]

2.1 Actual vapour compression heat pump cycle

In the analysis of an actual vapour compression heat pump cycle, the properties namely, specific internal energy (u), pressure (P) and specific volume (v) of the working fluid are significant. In this regard, these properties are combined from a simplification point of view as,

$$h = u + P \cdot v \quad (2.1)$$

This property is termed as specific enthalpy (h) and has the unit in ($\frac{kJ}{Kg}$).

Pressure-enthalpy diagram

The pressure-enthalpy ($P-h$) diagram plays an important role in understanding and analysing a vapour compression heat pump cycle. The $P-h$ diagram

of the refrigerant R134a is shown in figure 2.2. The vapour dome (the dome with black outline filled with green lines) indicates the region where, the refrigerant is partly vapour and partly liquid. The black line of the vapor dome on the left hand side represents saturated liquid and that on the right hand side represents saturated vapour. The region towards the left and right of the vapour dome, indicates liquid and vapour states of the refrigerant respectively. Both temperature (dark blue line) and pressure are constant inside the vapour dome. The green lines represents quality, indicating the percentage of vapour present in the liquid-vapour mixture.

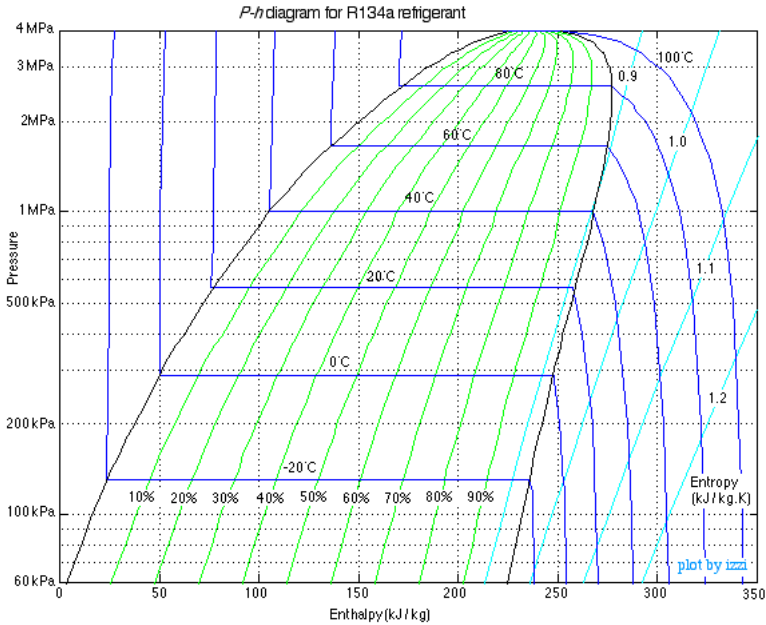

Figure 2.2: pressure enthalpy diagram of refrigerant R134a [2]

Along with enthalpy, another thermodynamic property of interest is entropy. It indicates the measure of disorderliness of a substance during different states or the kinetic energy lost or energy unavailable for doing useful work ($\frac{kJ}{KgK}$). In figure 2.2, entropy is represented by the lines in aqua colour.

Given any two intensive independent properties (eg: density, pressure, temperature) for a refrigerant (provided the state is fixed), other properties can

- **Compressor:** The superheated refrigerant at the outlet of the evaporator enters the compressor. Here the refrigerant is compressed to obtain a high temperature and a high pressure vapour. The compressor performs this operation by consuming electric power. In this stage, there is only work done and no heat addition. The states of the refrigerant at the inlet and outlet of the compressor are represented by '1' and '2' respectively.

The actual power consumption for this process is indicated by the dotted line connecting states 1 and 2'. There is no heat addition taking place during this process, and hence it is adiabatic. The work done by the compressor is given by

$$\dot{W}_{comp} = \frac{\dot{m}(h_2 - h_1)}{\eta_{isent}} \quad (2.2)$$

Here, η_{isent} represents the isentropic efficiency, h_2 and h_1 represents the enthalpy at the outlet and inlet of the compressor in $(\frac{kJ}{Kg})$.

- **Condenser:** The high pressure and high temperature refrigerant at the outlet of the compressor, enters the condenser. In the condenser, the refrigerant rejects the heat by initially undergoing desuperheating. '2s' represents the state of a saturated vapour at a high pressure and a high temperature. This is followed by the heat rejection at a constant temperature. This process occurs when the state of refrigerant changes from '2s' to '3s'. The state '3s' represents the state of saturated liquid. Furthermore, the refrigerant is subcooled. There is no work done by the condenser and only heat is rejected. The heat rejected by the condenser is given by

$$\dot{Q}_{out} = \dot{m}(h_2 - h_3) \quad (2.3)$$

Here, h_2 and h_3 represents the enthalpy at the inlet and outlet of the condenser in $(\frac{kJ}{Kg})$.

- **Expansion valve:** The refrigerant enters the expansion valve at state '3'. Here, the refrigerant undergoes expansion and enters the evaporator. This process is represented by the line connecting the states 3 and 4. During this process, no heat addition/rejection takes place and no work

is done. This process is adiabatic and isenthalpic (The enthalpy of the refrigerant remains same at the inlet and outlet of the expansion valve). Again, the refrigerant enters the evaporator and the cycle continues.

2.2 Compressors

Compressor is the heart of a heat pump. The manufactures of compressors will provide operating envelopes, indicating the conditions within which the compressors can operate safely and performance is guaranteed. Scroll compressors are a common type of compressors used in heat pumps for residential applications. Hence, the focus will be on scroll compressors.

An example operating envelope for a scroll compressor is shown in figure 2.4. The envelopes indicate the limitations of the compressor's operation in terms of maximum condensing temperature and minimum speed for a given evaporating temperature. For instance, the inner most blue envelope indicates that the compressor should run at a minimum speed of 900 RPM for a given set of condenser and evaporator temperatures.

Based on speed, there are two types of compressors namely fixed and variable speed compressors. In variable speed compressors, the speed is adjusted to deliver appropriate heat, for maintaining the temperature set by the users. However, this is subjected to the constraints provided by the operating envelope of the compressor. For example, from figure 2.4, the minimum speed at which the compressor can operate is 900 RPM. The compressor cannot be operated below this speed.

2.3 Model for refrigerant's mass flow rate in scroll compressors

The model for the refrigerant mass flow rate ($\frac{Kg}{s}$), for both variable and fix speed compressors is estimated as

$$\dot{m} = \frac{V_{dis}\rho_s f \eta_{vol}}{10^6} \quad (2.4)$$

Here, V_{dis} is the compressor displacement volume in ($\frac{cc}{rev}$), ρ_s is the density at suction in ($\frac{Kg}{m^3}$), f is the compressor speed in Hz, and η_{vol} is the volumetric

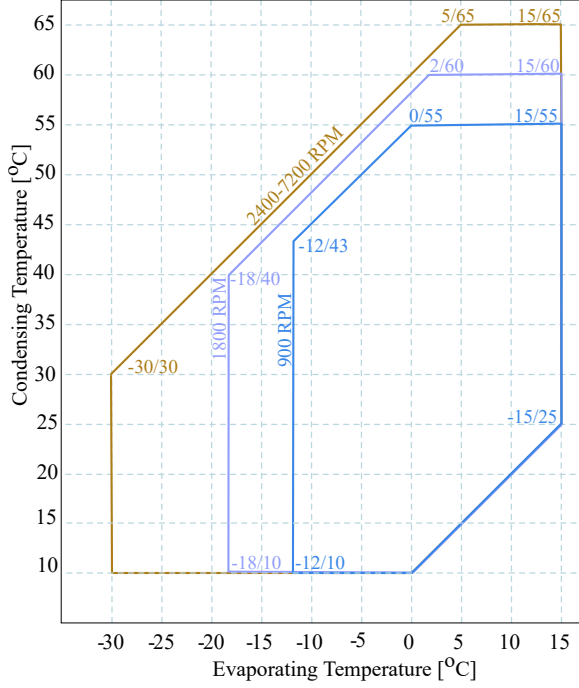

Figure 2.4: Scroll compressor operating envelope [4]

efficiency [5].

The correlation between the estimated and experimental values for the mass flow rate in [5] was strong with an error margin of $\pm 10\%$.

2.4 Performance indicator of heat pumps

The performance of a heat pump is evaluated in terms of Coefficient of Performance (COP). The COP for any heat pump cycle is given by

$$COP = \frac{\text{Heat delivered}}{\text{Work done by compressor}} = \frac{\dot{m}(h_2 - h_3)}{\frac{\dot{m}(h_2 - h_1)}{\eta_{isent}}} \quad (2.5)$$

The maximum theoretical COP (Carnot heat pump) for any heat pump

operating between the source and sink temperatures of T_C and T_H (both in K) respectively can be formulated as

$$COP = \frac{T_H}{T_H - T_C} \quad (2.6)$$

2.5 Vapour injection in scroll compressors

The operating envelope and COP of a heat pump at low source temperatures, can be increased by incorporating vapour injection in an actual vapour compression heat pump cycle. This can be realised using an economiser (a combination of heat exchanger and expansion valve). The representation of vapour injection in a vapour compression cycle with the associated components in a heat pump and on a pressure-enthalpy diagram is shown in figures 2.5 and 2.6 respectively.

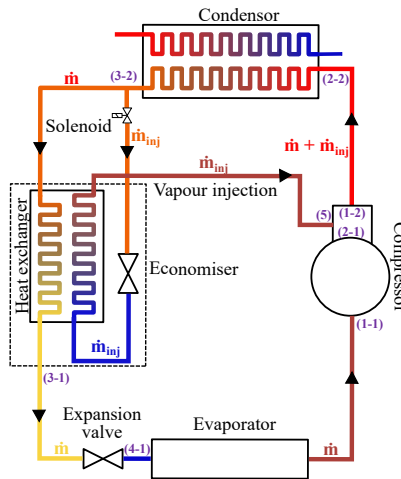

Figure 2.5: Vapour injection in scroll compressors [6]

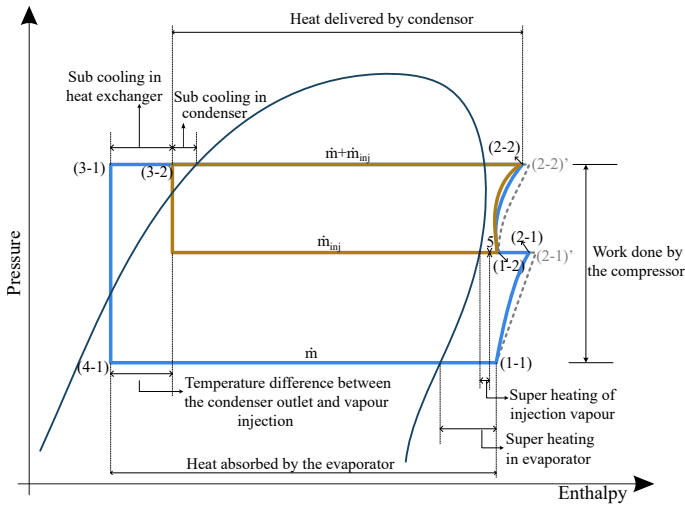

Figure 2.6: Vapour compression heat pump cycle with vapour injection [6]

2.6 Procedure for calculating the COP of a heat pump using the thermodynamic tables

The vapour compression heat pump cycle can be analysed for different operating conditions and the COP can be estimated using the Coolprop library [7]. The Coolprop library includes thermodynamic tables for various refrigerants.

Vapour compression heat pump cycle without vapour injection

The procedure for the calculation of COP, without vapour injection is as explained in [8].

Vapour compression heat pump cycle with vapour injection

The actual vapour compression heat pump cycle with vapour injection, operates at three pressures corresponding to the pressures of evaporator, vapour

injection and condenser. The subsequent explanation will be based on figures 2.5 and 2.6. With this background, the procedure employed for the calculations with appropriate reasoning is listed below [6][9] :

1. The pressure in the evaporator is determined using the information of the temperature at which evaporation occurs and the corresponding quality of saturated vapour.
2. The temperature for superheating is assumed to be 5 K[10]. The enthalpy ' h_{1-1} ' is determined using the details of the temperature at which the refrigerant is superheated and the pressure in the evaporator. Also, the entropy and density of the refrigerant are determined at the same condition (state: 1-1). This is followed by the calculation of mass flow rate using (2.4).
3. The temperature of vapour injection line (saturated temperature at an intermediate pressure) is approximated using the expression

$$T_{inj} = 0.8T_e + 0.5T_c - 21 \quad (2.7)$$

The terms T_e and T_c correspond to evaporator and condenser temperatures in °F. This is experimentally derived for vapour injection scroll compressor models ZF*KVE and ZF*K5E by Emerson climate technologies with an accuracy of ± 5 [6]. The approximation is suggested to be valid only when the evaporation temperature varies between -31.1 °C and 10 °C, followed by a variation of condenser temperature between -26.6 °C and 65.5 °C. However, (2.7) is valid even for the scroll compressor model ZH13KVE by Emerson climate technologies, dedicated for heat pumps. For other scroll compressors by different manufacturers, the vapour injection temperature corresponding to various combination of T_e and T_c can be obtained by contacting the manufacturers.

4. From an optimal system performance point of view, a temperature difference of 5 K is assumed in the following cases [10]:
 - Condenser subcooling
 - The temperature of the subcooled liquid at the outlet of economiser's heat exchanger (state:(3-1)) and the temperature of vapour injection line (T_{inj}).
 - The temperature of vapour injection at the outlet of injection port (state:5) and the temperature of vapour injection line (T_{inj}).

5. The pressure in the vapour injection line is determined using the temperature of the vapour injection line (T_{inj}) and the corresponding quality of the saturated vapour.
6. The enthalpy ' h_5 ' of the superheated vapour to be injected is determined using the temperature of injection vapour at the outlet of the injection port ($T_{inj}+5$) and the pressure in the vapour injection line.
7. The pressure in the condenser is estimated using the details of the temperature in the condenser and the quality of saturated liquid.
8. The enthalpy ' h_{3-2} ' at state (3-2), is determined using the details of the temperature in the condenser considering subcooling (T_c-5) and the pressure in the condenser.
9. The enthalpy ' h_{3-1} ' at state (3-1) is determined using the details of the temperature of the subcooled liquid at the outlet of economiser ($T_{inj}+5$) and the pressure in the condenser.
10. The mass flow rate of vapour injected is calculated based on the energy balance equation in the economiser and is given by

$$\dot{m}_{inj} = \frac{\dot{m}(h_{3-2} - h_{3-1})}{(h_5 - h_{3-2})} \quad (2.8)$$

11. The process of compression is assumed to be isentropic. So, the entropy of the vapour from the first compression (state: (2-1)) is assumed to be the same as that of the vapour at the outlet of the evaporator (state: (1-1)).
12. The enthalpy ' h_{2-1} ' at state (2-1), is determined using the details of entropy at state (2-1) and the pressure in the vapour injection line.
13. The enthalpy ' h_{1-2} ' at state (1-2), is obtained by using the energy balance equation at the vapour injection port of the compressor and is given by

$$\begin{aligned} \dot{m}_{inj}(h_{1-2} - h_5) &= \dot{m}(h_{2-1} - h_{1-2}) \\ h_{1-2} &= \frac{\dot{m}h_{2-1} + \dot{m}_{inj}h_5}{(\dot{m} + \dot{m}_{inj})} \end{aligned} \quad (2.9)$$

14. The entropy at state (1-2) is determined using the information of enthalpy at the same state and pressure corresponding to the vapour injection line.
15. As the process of compression is assumed to be isentropic, the entropy of state (2-2) is equal to the entropy at state (1-2). The enthalpy at

state (2-2) can be obtained by using the details of entropy at the same state and condenser pressure.

16. The work done by the compressor is given by

$$\dot{W}_{comp} = \frac{(\dot{m}(h_{2-1} - h_{1-1})) + ((\dot{m} + \dot{m}_{inj})(h_{2-2} - h_{1-2}))}{\eta_{isent}} \quad (2.10)$$

17. The COP of the heat pump is given by

$$COP = \frac{(\dot{m} + \dot{m}_{inj})(h_{2-2} - h_{3-2})}{\dot{W}_{comp}} \quad (2.11)$$

3.1 Thermal model of a house

The thermal model of a house can be represented as a simple series RC circuit, powered by a heat input from a heating source as a dependant current source. The outdoor ambient temperature which is an external condition is represented as a voltage source and is shown in figure 3.1. The heat input is modelled as a dependant current source as the heat delivering capability of a heat pump varies based on its source and sink temperatures.

The terms ' $C_{overall}$ ' and ' $R_{overall}$ ' are the total thermal mass and thermal resistance of a house respectively. ' $R_{overall}$ ' is obtained by taking the reciprocal of ' $U_{overall}$ '. ' $U_{overall}$ ' represents the total heat transfer co-efficient of the house. ' Q_{heat} ' and ' T_{amb} ' represents the heat from a heat pump and outdoor ambient temperature respectively. The indoor temperature is represented by the voltage ' T_{room} ' across the capacitor.

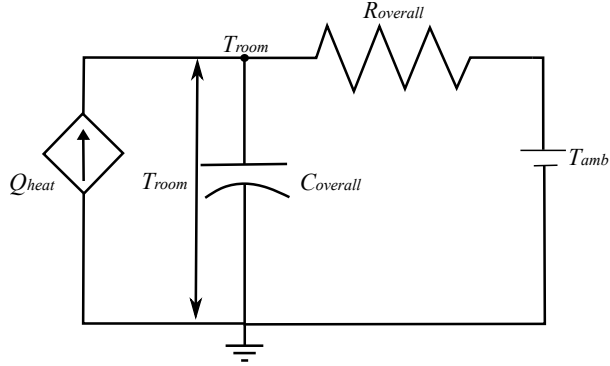

Figure 3.1: Simple thermal model of a building

3.2 Controller design for space heating

A process model is a mathematical model of a system whose specific output is to be controlled for maintaining it at a specified set point. This model aids in estimating the output for a given set of input conditions.

The first step in designing any controller is to determine the transfer function of the process model. The transfer function is the relationship between the desired output of the system (which is to be controlled) with respect to the input.

In figure 3.1, the output is ' T_{room} ' and inputs are ' Q_{heat} ' and ' T_{amb} '. The transfer function for this model is derived as follows:

Applying KCL (Kirchhoff's current law) to the circuit gives

$$Q_{heat}(t) = C_{overall} \frac{dT_{room}(t)}{dt} + \frac{T_{room}(t) - T_{amb}(t)}{R_{overall}} \quad (3.1)$$

Taking the Laplace transform on (3.1) and by rearranging the terms, the transfer function is obtained as

$$\frac{T_{room}(s)}{(Q_{heat}(s) + \frac{T_{amb}(s)}{R_{overall}})} = \frac{R_{overall}}{R_{overall}C_{overall}S + 1} \quad (3.2)$$

The controller design adopted in this study is based on [11] and the control diagram is shown in figure 3.2. A selector switch is used to ensure that there is no space heating provided when the heat pump is in water heating mode. Since, the values in the term ' $\frac{T_{amb}}{R_{overall}}$ ' is known, it is modelled as a feed-forward. The saturation block is modelled as an adaptive limiter.

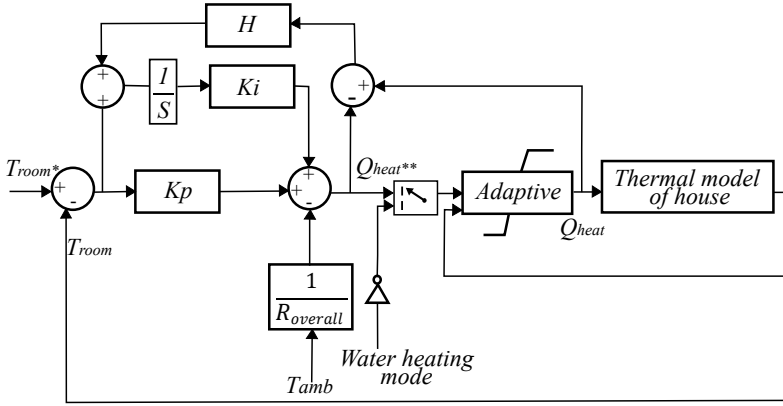

Figure 3.2: Block diagram of the controller for space heating

Saturation block as an adaptive limiter:

The heat delivering capability is limited by the space heating system comprising of radiators/floor heating and the heat pump. In this model, the saturation block (i.e, practical limitations of the space heating system) is modelled as an adaptive limiter. This is because, the heat delivering capability of the heat pump is dependant on the source and sink temperatures. Furthermore, the heat emitted by the radiators is limited by the supply, return temperature of water and the room temperature.

The thermal output of the radiators at different conditions is estimated based on the reference values (Thermal output of the radiator at standard conditions i.e, 55/45/20°C. These temperatures represent the supply and return temperatures of the water in the radiator followed by the indoor room temperature) and data provided in [12] as

$$Q_{heat_{rad}} = Q_{heat,ref@standard} \left(\frac{\Delta T}{\Delta T_{ref@standard}} \right)^n \quad (3.3)$$

Where, $Q_{heat_{rad}}$ is the thermal output of radiator in W, $Q_{heat,ref@standard}$ is the thermal output of radiator at standard conditions (55/45/20 °C) in W, ΔT is the arithmetic or logarithmic temperature difference in °C, $\Delta T_{ref@standard}$ is the arithmetic temperature difference calculated at standard conditions and n is the exponent characteristic of the radiator.

The selection of arithmetic or logarithmic temperature difference for ΔT is based on the condition, $\left(\frac{T_{return} - T_{room}}{T_{supply} - T_{room}} \right) < 0.7$. If the condition is met, then logarithmic temperature difference should be used, else arithmetic temperature difference should be considered. T_{return} and T_{supply} are the supply and return temperature of the water in the radiator. T_{room} is the indoor room temperature. The arithmetic and logarithmic temperature difference is calculated as

$$\begin{aligned} \Delta T_{log} &= \frac{T_{supply} - T_{return}}{\ln \left(\frac{T_{supply} - T_{room}}{T_{return} - T_{room}} \right)} \\ \Delta T_{arth} &= \left(\frac{T_{supply} + T_{return}}{2} \right) - T_{room} \end{aligned} \quad (3.4)$$

Observing (3.3) it is noticed that, it is challenging to calculate the values of supply and return temperature of the water, for a given value of room temperature and heat. Thus, the heat delivered by the radiator/floor heating system is calculated for various values of supply, return temperature of water and room temperature. Furthermore, these results are tabulated and formulated into a look up table.

Based on the actual room temperature and reference heat from the controller, the look up table provides the supply, return temperature of the water in radiator and the mass flow rate. However, the look up table will not provide the information regarding the value of heat to which the reference heat from the controller is approximated to. Hence, based on the supply and return temperature of the water, obtained by the look up table, also considering the reference heat from the controller and actual room temperature, the actual heat emitted by the radiator with corresponding mass flow rate is determined again using (3.3) and (3.4). Thus, the heat emitted by the radiators is ob-

tained.

The condenser temperature ' T_{cond} ' in the heat pump (sink temperature), based on the supply and return temperature of the water [13] can be computed as

$$T_{cond} = T_{return} + \frac{T_{supply} - T_{return}}{1 - e^{-\frac{(T_{supply} - T_{return})}{\Delta T_{log.cond}}}} \quad (3.5)$$

$\Delta T_{log.cond}$, is the logarithmic temperature difference of the heat exchange and is assumed to be 4 K.

The results from the heat pump modelling considering the entire operating envelope are tabulated and formulated into look up tables. Based on the information of condenser temperature, heat delivered by the radiators and source temperature in the heat pump, the corresponding values of speed, electric power needs and utilization of direct electric heating by the heat pump can be obtained.

3.3 Stratified layer model of domestic hot water tank

The temperature of a stratified hot water tank can be estimated through state space model and is represented in figure 3.3.

The detailed mathematical modelling is described in [14].

3.4 Controller design for water heating

A simple model of a domestic hot water tank without any stratification is shown in figure 3.4. Here, ' $Q_{withdrawl}$ ' represents the heat loss in the water tank due to water withdrawal, ' Q_{heat} ' represents the heat from the heat pump and ' C_{tank} ' is the thermal mass of water in the tank. ' T_{room} ' and ' T_{water} ' represents the room and water temperature in the tank respectively.

Applying KCL to circuit gives

$$C_{tank} \frac{dT_{water}(t)}{dt} = Q_{heat}(t) + Q_{withdrawl}(t) + \frac{T_{room}(t) - T_{water}(t)}{R_{tank}} \quad (3.6)$$

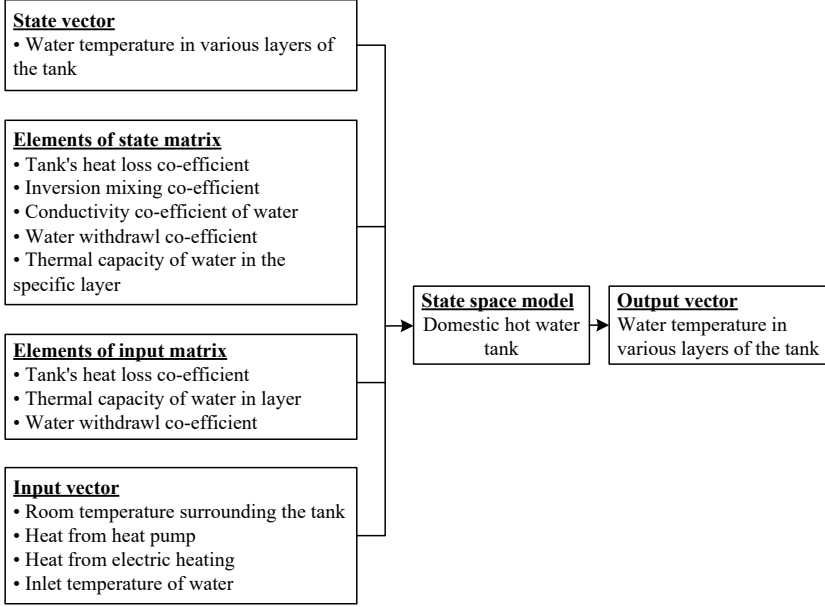

Figure 3.3: Model for estimating the temperature in domestic hot water tank

where, R_{tank} is the reciprocal of water tank's heat transfer coefficient. $Q_{withdrawal}$ can be written as

$$Q_{withdrawal}(t) = \dot{m}_{water}(t)C_{water}(T_{in}(t) - T_{water}(t)) \quad (3.7)$$

where \dot{m}_{water} is the mass flow rate of the water being extracted, C_{water} is the specific heat capacity of the water and T_{in} is the inlet water temperature.

Taking Laplace transform on (3.6) and by rearranging the terms, the transfer function is obtained as

$$\frac{T_{water}(s)}{(Q_{heat}(s) + \frac{T_{room}(s)}{R_{tank}}) + \dot{m}_{water}(s)C_{water}T_{in}(s)} = \frac{R_{tank}}{R_{tank}(C_{tank}S + \dot{m}_{water}C_{water}) + 1} \quad (3.8)$$

As the rate at which hot water is drawn, the temperature of water at the inlet, the indoor temperature can be measured and as the heat transfer coeffi-

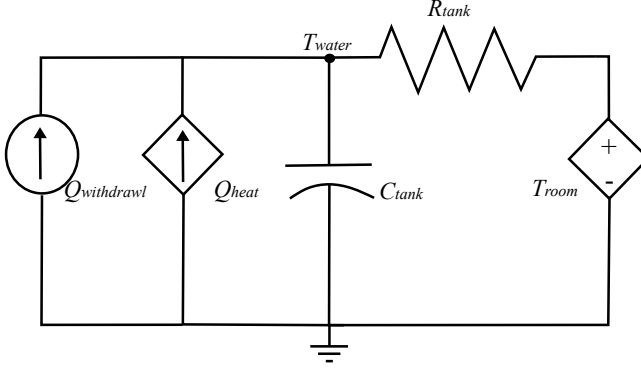

Figure 3.4: Simple model for a domestic hot water tank

cient of the tank is known, the terms involving these parameters are modelled as a feed forward.

Based on this, the block diagram of a domestic hot water controller is shown in figure 3.5. A dead band of $1^{\circ}C$ is used.

Saturation block as an adaptive limiter:

The heat delivering capability in the hot water tank is limited by the water heating system comprising of a hot water coil and a heat pump. In this model also, the saturation block is modelled as an adaptive limiter as in the case of the controller for space heating. This is because, the heat delivering capability of the heat pump is dependant on the source and sink temperatures. Furthermore, the heat emitted by the hot water is limited by the supply, return temperature of water and the water temperature in the layers in which the hot water coil is placed.

The thermal output of the hot water coil at different conditions is estimated to be

$$Q_{heat} = UA_{hotwatercoil} \left(\frac{T_{supply} + T_{return}}{2} \right) - T_{avgL(i+m)...L(i+n)} \quad (3.9)$$

$UA_{hotwatercoil}$ represents the heat transfer coefficient of the hot water coil

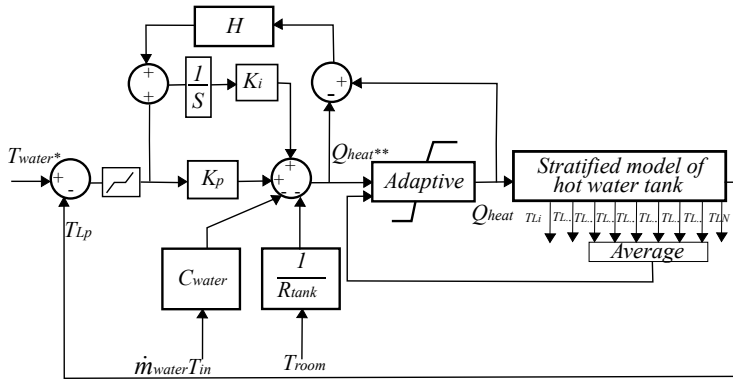

Figure 3.5: Block diagram of the controller for water heating

and $T_{avgL(i+m)\dots L(i+n)}$ represents the average temperature of water in layers (i+m) to (i+n), where the hot water coil is placed.

By observing (3.9) it is noticed that, it is challenging to calculate the values of supply and return temperature of water for a given value of average water temperature in layers (i+m) to (i+n). Thus, the heat delivered by the hot water coil is calculated for various values of supply, return temperature of water in the hot water coil and average water temperature in layers (i+m) to (i+n). These results are tabulated and formulated into a look up table.

The procedure for obtaining the speed, electric power needs and utilization of direct electric heating by the heat pump is explained in section 3.2.

3.5 Controller design for providing space and water heating

The block diagram of the controller providing space and water heating is shown in figure 3.6.

Depending on the requirement, appropriate control mode i.e., space or water heating is selected. For example, if the controller is in water heating mode, the input would be the error signal obtained from reference temperature for water ' T_{water}^* ' and the actual temperature of water ' $T_{water, TLP}$ ', obtained from a sensor placed at a specific location in the domestic hot water tank. Based on

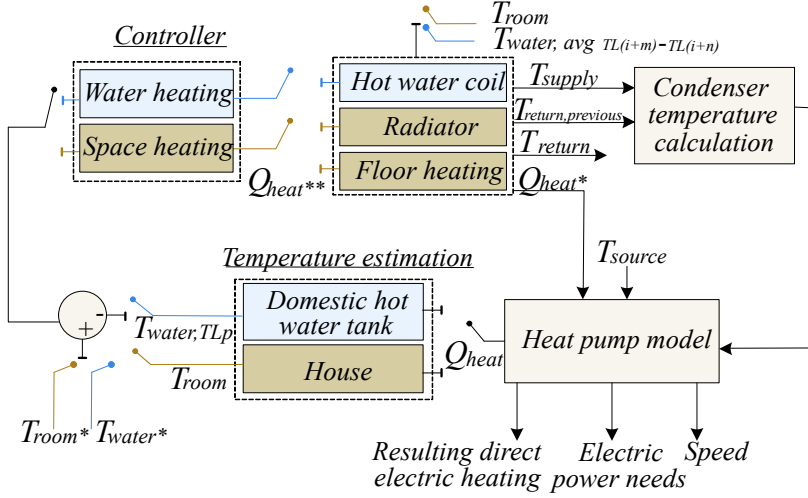

Figure 3.6: Controller design for providing space and water heating

the error signal, the controller provides a reference signal for heat ' Q_{heat}^{**} '. Depending on ' Q_{heat}^{**} ' and the average temperature of water in which the hot water coil is placed, the look up table for the hot water coil provides, the required value of supply and return temperature of water. This is followed by calculation of the actual value of heat that can be provided ' Q_{heat}^* ' using (3.9). Based on the supply and the previous return temperature of water, the condenser temperature in the heat pump is calculated using (3.5). Using the condenser temperature, source temperature of the heat pump ' T_{source} ' and ' Q_{heat}^* ', the look up table from the heat pump model provides, the speed, the utilisation of direct heating, electric power needs, and the actual value of heat ' Q_{heat} ' that can be provided. Based on the value of ' Q_{heat} ' released into the water in the domestic hot water tank, the water temperature is estimated.

References

- [1] G. Narsilio, I. Johnston, A. Bidarmaghz, O. Mikhaylova, A. Kivi, and R. Aditya, “Geothermal Energy: Introducing an Emerging Technology,” in *International Conference on Advances in Civil Engineering for Sustainable Development*, Suranaree University of Technology, 2014, pp. 141–154.
- [2] Ohio University. “P-h diagram for r134a refrigerant.” (2022), [Online]. Available: https://www.ohio.edu/mechanical/thermo/property_tables/R134a/ph_r134a.html (visited on 02/25/2022).
- [3] N. Kocyigit, H. Bulgurcu, and C.-X. Lin, “Fault diagnosis of a vapor compression refrigeration system with hermetic reciprocating compressor based on p-h diagram,” *International Journal of Refrigeration*, vol. 45, pp. 44–54, 2014, ISSN: 0140-7007.
- [4] CopelandTM, “Emerson Climate Technologies,” in *CopelandTM Scroll Variable speed compressors for residential air conditioning applications*, (Accessed on 04/03/2022), Emerson Electric Co., 2020.
- [5] N. Park, J. Y. Shin, and B. Y. Chung, “A new dynamic heat pump simulation model with variable speed compressors under frosting conditions,” in *8th International Conference on Compressors and their Systems*, ScienceDirect, 2013, pp. 681–696.
- [6] Emerson Climate Technologies, “Economized Vapor Injection (EVI) for ZF*KVE and ZF*K5E Compressors,” in *Application Engineering Bulletin*, Emerson Climate Technologies, 2019, pp. 1–29.

- [7] I. H. Bell, J. Wronski, S. Quoilin, and V. Lemort, “Pure and pseudo-pure fluid thermophysical property evaluation and the open-source thermophysical property library coolprop,” *Industrial & Engineering Chemistry Research*, vol. 53, no. 6, pp. 2498–2508, 2014.
- [8] S. K. Nalini Ramakrishna, T. Thiringer, and C. Markusson, “Quantification of electrical load flexibility offered by an air to water heat pump equipped single-family residential building in sweden,” in *14th IEA, Heat pump conference*, 2023.
- [9] T. W. Moesch, A. M. Bahman, and E. A. Groll, “Performance Testing of a Vapor Injection Scroll Compressor with R407C,” in *International Compressor Engineering Conference*, Purdue University, 2016, pp. 1–10.
- [10] Emerson Climate Technologies. “Scroll compressors with vapour injection for dedicated heat pumps.” (2022), [Online]. Available: http://www.sklep-klimatyzacja.pl/dokumentacje/COPELAND_dok_2006/EN_C060217_AGL_ZHEVI.pdf (visited on 02/25/2022).
- [11] S. Lundberg, “Rl circuit current control, lecture slides, electric drive systems enm 076,” *Chalmers University of Technology*, no. January, 2022.
- [12] Purmo. “Technical catalogue, panel radiators.” (), [Online]. Available: https://www.purmo.com/docs/Purmo-technical-catalogue-full-panel-radiators-10_2021_EN.pdf (visited on 05/01/2022).
- [13] M. Maivel and J. Kurnitski, “Heating system return temperature effect on heat pump performance,” *Energy and Buildings*, vol. 94, pp. 71–79, 2015.
- [14] S. K. Nalini Ramakrishna and T. Thiringer, “Domestic hot water heat pump: Modelling, analysis and flexibility assessment (in press),” in *IEEE PES 15th Asia-Pacific Power and Energy Engineering Conference*, 2023.