



A review of industrial tracking control algorithms

Downloaded from: <https://research.chalmers.se>, 2026-04-05 08:34 UTC

Citation for the original published paper (version of record):

Yuan, M. (2020). A review of industrial tracking control algorithms. *Control Engineering Practice*, 102: 104536-. <http://dx.doi.org/10.1016/j.conengprac.2020.104536>

N.B. When citing this work, cite the original published paper.



A review of industrial tracking control algorithms[☆]

Meng Yuan^{a,*}, Chris Manzie^a, Malcolm Good^b, Iman Shames^a, Lu Gan^c, Farzad Keynejad^c, Troy Robinette^c

^a Department of Electrical and Electronic Engineering, The University of Melbourne, Parkville, VIC 3010, Australia

^b Department of Mechanical Engineering, The University of Melbourne, Parkville, VIC 3010, Australia

^c ANCA Motion, Bayswater North 3153, Australia

ARTICLE INFO

Keywords:

Trajectory tracking
Motion control
Industrial machines

ABSTRACT

Advanced manufacturing is characterised by machines that move an end effector through a given trajectory to perform operations such as cutting, grinding and printing. In many industrial machines, properties such as structural flexibility, external disturbances as well as spatially separate actuator and end effector make the tracking problem challenging. In this paper, a literature survey on trajectory tracking control algorithms is conducted to examine representative features of existing methods. Then the major classes of algorithms are compared on a commercial single-axis test bench to provide practitioners with a direct insight into the trade-off between performance and implementation.

1. Introduction

In 2016, the size of the global industrial motion control market was \$US16.54 billion and it is expected to reach approximately \$US22.8 billion by 2022 (Statista, 2018). To retain a competitive advantage in the manufacturing market, two competing characteristics of speed and precision are typically used to assess the performance of an industrial machine. Improving speed leads to higher throughput and productivity, yet it may compromise the precision and ability to meet a given manufacturing tolerance. To realise accurate manufacturing, trajectory tracking control is essential and has been investigated in many industrial applications including precise positioning (Lee & Tomizuka, 1996; Liu, Luo, & Rahman, 2005; Lu, Chen, Yao, & Wang, 2013), servo drive control (Chen, Yao, & Wang, 2013a, 2013b; Hanifzadegan & Nagamune, 2015) and machine tools (Huang, Liu, Hsu, & Yeh, 2010; Stephens, Manzie, & Good, 2013; Yao, Al-Majed, & Tomizuka, 1997).

The desire to reduce machine cost whilst retaining high speed and acceleration properties has also led to lighter structures for given motor specifications (Luca & Siciliano, 1989; Rahimi & Nazemizadeh, 2014). The lighter components lead to more flexible mechanical structures. The inherent flexibility of the transmission parts and the non-rigid characteristics of the lighter manipulator result in vibration and oscillation during the manufacturing process. The resulting vibration not only deteriorates the tracking accuracy but also reduces the throughput,

as avoiding vibration requires lower acceleration and jerk reference trajectories (Meckl & Seering, 1985). Control of machines with flexible manipulators has been considered for gantry machines (Gordon & Erkorkmaz, 2012), machine tools (Stephens, Manzie, & Good, 2010), servo drive system (Cychowski, Szabat, & Orłowska-Kowalska, 2009; Okwudire & Altintas, 2009; Thomsen, Hoffmann, & Fuchs, 2011) and robotics (Cannon & Schmitz, 1984; Li & Chen, 2001). Further, Benosman and Le Vey (2004) and Dwivedy and Eberhard (2006) review the modelling and control methods of flexible manipulators since the 1970s and Lochan, Roy, and Subudhi (2016) reviews approaches specific to the two-link manipulator, although issues around disturbance rejection and spatially separate actuator and end effector are not considered therein.

In addition to structural flexibility, the non-rigid feature of transmission parts and manipulator may cause a discrepancy between the drive and load (or end effector) position. For systems without end-effector position measurement, an observer is generally required to estimate the load side states (Cychowski et al., 2009). A detailed review of the challenges this induces is provided in Kiang, Spowage, and Yoong (2015). Furthermore, the disturbances on the drive and load side can deteriorate the trajectory tracking performance leading to proposed compensatory methods like adaptive control (Pradhan & Subudhi, 2014; Yao, Jiao, & Ma, 2014). Meanwhile, disturbance-observer-based approaches have also been proposed to account for the

[☆] This work is supported by the University of Melbourne through Melbourne International Fee Remission Scholarship (MIFRS) and Melbourne International Research Scholarship (MIRS).

* Corresponding author.

E-mail addresses: yuanm3@student.unimelb.edu.au (M. Yuan), manziec@unimelb.edu.au (C. Manzie), mccgood@unimelb.edu.au (M. Good), iman.shames@unimelb.edu.au (I. Shames), lu.gan@ancamotion.com (L. Gan), farzad.keynejad@ancamotion.com (F. Keynejad), troy.robinette@ancamotion.com (T. Robinette).

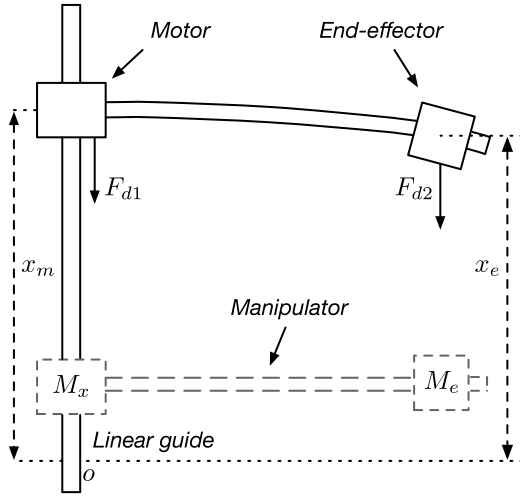

Fig. 1. Schematic diagram of investigated system with structural flexibility.

presence of unmodelled dynamics (Li, Xia, & Zhou, 2012; Yun, Su, Kim, & Kim, 2013).

Although numerous control methods are proposed, the proportional–integral–derivative (PID)-based cascaded control is still the most prevalent in industry (Visioli & Legnani, 2002), due to a combination of factors including its relatively simple design and low implementation cost. However, with the ever-increasing demands on industrial machining, there is a need to objectively assess when the benefits of advanced controller architectures might provide sufficient motivation to consider alternatives to the PID-based approaches.

The objective of this paper is to conduct a literature survey of existing trajectory tracking control methods and identify the features of representative methods. The tracking performance and associated implementation challenges will be investigated using a platform containing structural flexibility, external disturbances and spatially separate actuator and end effector. For a fair comparison, the experiments of all investigated controllers are conducted on the same single-axis test bench.

The rest of the paper is organised as follows: In Section 2, the dynamic model describing the system of interest is formulated. Section 3 categorises the existing control laws, while the experimental set-up and results quantifying the performance of the different algorithm classes are presented in Section 4.

2. System description

The one-dimensional systems under consideration include drives with flexible transmissions and machines with flexible manipulators. Such systems can be uniformly represented as Fig. 1. This schematic shows two snapshots of the system, with the lower (dotted grey line) indicating a steady state when the end-effector position, x_e is equal to the motor position, x_m ; and the upper (solid black line) indicating an orientation during dynamic behaviour $x_e \neq x_m$.

In a lumped parameter approximation, M_m and M_e represent the equivalent mass of the motor and load; while F_{d1} and F_{d2} stand for the lumped disturbances on the motor and end effector respectively. The latter may include physical disturbance as well as influences arising from un-modelled dynamics or imperfect model parameters.

If first order approximations of the dynamics are modelled with all higher order modes relegated to part of the disturbance terms, the system can be represented by the following equations:

$$\begin{aligned} \dot{x}_m &= v_m, \\ \dot{v}_m &= \frac{1}{M_m} (k_t u - k_s (x_m - x_e) - c_s (v_m - v_e) - F_{d1}), \end{aligned} \quad (1)$$

$$\begin{aligned} \dot{x}_e &= v_e, \\ \dot{v}_e &= \frac{1}{M_e} (k_s (x_m - x_e) + c_s (v_m - v_e) - F_{d2}), \end{aligned} \quad (2)$$

Here $v_m = \dot{x}_m$ and $v_e = \dot{x}_e$ are the velocity of the motor and load respectively; u represents the current to the motor; k_t is the equivalent force constant of the motor; k_s and c_s are the equivalent spring constant and internal damping coefficient of the flexible mechanical components.

This control-oriented model structure has been used to describe many industrial applications including ball screw mechanisms (Erkorkmaz & Hosseinkhani, 2013; Gordon & Erkorkmaz, 2013; Okwudire & Altintas, 2009; Zhang & Chen, 2016), conveyor belt (Hace, Jezernik, & Šabanović, 2007) and two-mass drive with shaft elasticity (Fuentes, Silva, & Yuz, 2012; Serkies & Szabat, 2013).

Furthermore, in many related works such as (Zhu, Ge, & Lee, 1999), it has been demonstrated this lumped parameter model (2) can lead to effective tracking of a reference trajectory by the end effector in single-link flexible manipulators.

3. Review of industrial tracking control algorithms

The general industrial motion controller is usually given in the structure as shown in Fig. 2. Since the time scale of the electrical subsystem is much faster than the mechanical subsystem, the design of the current controller, which is usually done at the drive level, is not the main focus of this review paper. In practical implementations, the control input includes a disturbance d_i , while the measured position x_m and velocity v_m are contaminated by sensor noise d_m . The baseline controller is designed based on the position reference x_e^* , the measured motor position \bar{x}_m and motor velocity \bar{v}_m .

Note that several industrial motion control problems (e.g. spindle control of machine tools) require accurate velocity tracking. In such cases, the position loop in Fig. 2 can be disengaged and only velocity and current control loop are required. The ensuing discussion can be applicable under this modified architecture.

For position control, the existing control approaches to provide trajectory tracking in a system with dynamics (1) and (2) are grouped into three classes. The first class of algorithms do not utilise an explicit model of the system in their development, and consist of variations on traditional PID approaches, H_∞ control and sliding mode control. The second class of algorithms use observers to estimate the disturbances in the system, in order to provide pre-emptive disturbance compensation in the control input. The final class considers explicit use of the system dynamics in the calculation of the control input, and are known as model-based approaches.

3.1. Non-model-based feedback control

Non-model-based feedback controllers do not utilise an explicit form of system dynamics in the controller design (Ge, Lee, & Zhu, 1997). The low commissioning effort and relatively low computation load make non-model based feedback control easy for implementation in trajectory tracking applications, and these are highly utilised in industry implementations. The approach can be further divided into a number of categorisations.

3.1.1. PID-based cascaded control

Despite many advanced control algorithms being proposed for trajectory tracking, by far the most adopted controller in industrial settings is still the PID-based cascaded control (Visioli & Legnani, 2002). The standard cascaded controller consists of three control loops, namely position, velocity and current loop from outside to inside. In the outermost loop, the position controller uses the error between the desired and measured position to generate the command for the velocity loop. In a similar way, the velocity controller in the middle loop uses the velocity difference to calculate the reference signal for the innermost current loop. For the innermost loop, the current error is used as

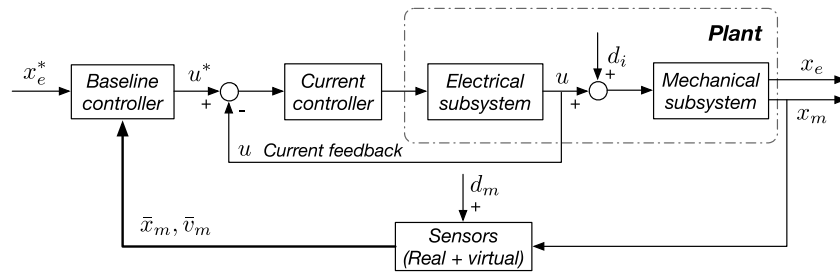

Fig. 2. Schematic diagram of industrial trajectory tracking controller.

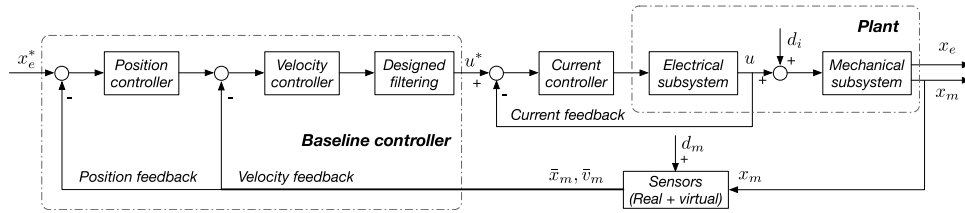

Fig. 3. Schematic diagram of cascaded control with filtering for trajectory tracking.

the input to the current controller for generating the voltage required to drive the motor (Buja & Kazmierkowski, 2004). The core idea of cascaded control is to feedback intermediate variables that lie between the disturbance injection point and the output (Goodwin, Graebe, & Salgado, 2000). Note, however, the disturbances on each loop are effectively treated as constants that are rejected by the integral action of the corresponding controller.

Structural flexibility in the system can lead to high-frequency vibration and reduce tracking performance at the end-effector side in industrial machines. The standard PID-based cascaded structure is not able to directly handle these types of disturbances, and so many modifications to the structure have been considered.

Active approaches rely on additional sensing such as position and velocity of the end-effector side (Vukosavic & Stojic, 1998), and build this into the velocity feedback loop. In Szabat and Orłowska-Kowalska (2007), a comparative study of various PI-based controller structures for the speed and current loops was conducted. The approaches considered additional feedback for vibration suppression in systems with a flexible connection, and theoretical and experimental results demonstrated that the resonant frequency could be shifted sufficiently to avoid speed oscillations in the closed-loop system. The primary disadvantage of this approach is the need for sensors at the end effector, which may be impractical from both a cost and placement perspective in practice.

Alternatively, the flexibility of the structure may be ignored and the measurements of the motor are used in place of the end-effector position (Erkorkmaz & Altintas, 2001; Poignet, Gautier, & Khalil, 1999). In systems with some degree of flexibility, using the collocated control architecture to control the position of the end effector leads to a non-minimum phase system which requires detuning the control gains.

Instead of using additional sensors and/or redesigning the mechanical hardware, ‘passive’ approaches intended to avoid vibration being initiated have been used widely in practice. These can involve command shaping, where the reference is modified to remove energy around the natural frequencies of the system. By doing so, the vibration modes of the system are not excited, thus reducing the residual vibration during the process (Mohamed & Tokhi, 2004; Singhose, 2009). As one example, the input shaping in Singer and Seering (1990) involves convolving the desired command with a sequence of impulses, where the amplitude and time locations of the impulses are determined based on the natural frequencies and damping ratio of the system.

As another passive approach to deal with unmodelled dynamics online, Fig. 3 illustrates how filtering may be included in an industrial trajectory tracking application. Here the signal generated by the

velocity controller is subjected to input shaping before serving as the current command. Note that without the filtering block, the structure demonstrated in Fig. 3 reduces to the standard cascaded controller. In Singhose (2009), different methods including low-pass and notch filters are described in detail, while the performance comparisons of filtering and input shaping schemes can be found in Mohamed and Tokhi (2004), Singer, Singhose, and Seering (1999) and Singhose and Vaughan (2011).

Due to the mechanical coupling between the motor and the end effector, vibration at the end effector induces oscillations in the motor current and position. Consequently, the filtering schemes above indirectly target the end-effector vibration, with the effectiveness being discussed in applications including ball screw drives (Erkorkmaz & Hosseinkhani, 2013; Gordon & Erkorkmaz, 2013; Lee, Lee, & Ahn, 2012) and servo drive systems (Bahn, Kim, Lee, & Cho, 2017; Vukosavic & Stojic, 1998).

In summary, the additional filtering augments the standard cascaded controller to increase the closed-loop bandwidth slightly. This is achieved by attenuating the detrimental frequency-domain effects of resonance and anti-resonance on the closed-loop transfer function through careful filter design. However, this approach does not target other sources of performance degradation arising from system nonlinearities and other time-varying or unmodelled dynamics.

3.1.2. Non-model-based robust control

The cascaded controller is designed based on the assumption that the different loops are separated in time scales so that independent controller design is possible. Using PI-variants on the loops is ideally suited for rejection of slowly varying (in the time scale inherent to the loop of interest) varying disturbances. However, controller calibration that does not consider structural flexibility or changes due to variation in machine characteristics may lead to poor tracking in a given loop. This can then detrimentally impact on the performance of subsequent outer loops (Bonivento, Nersisyan, & Zanasi, 1994).

The desire to improve the robustness of the closed-loop system to these variations has seen proposed solutions including the controller calibration that explicitly considers parameter variation through tuning subject to constraints on gain margin or sensitivity (Garpinger, Häggglund, & Åström, 2014; Sekara & Matausek, 2009).

Other non-model based robust control methodologies such as H_∞ control have also been proposed (Van Brussel & Van den Braembussche,

1998). The H_∞ control explicitly considers the robustness of the system; however, it requires more system information than the cascaded controller as the frequency spectrum of possible disturbances is required for control synthesis. Although the robustness and performance are considered during the H_∞ design process, the control performance of H_∞ is conservative, since the worst scenario of disturbance is considered, and there is always a compromise between the performance and robustness when a purely H_∞ controller is used (Amann, Owens, Rogers, & Wahl, 1996).

Furthermore, the design of the controller is often complicated. To simplify the H_∞ control design, (Li & Liu, 2009), proposed combining it with dynamic surface control. The authors applied the approach for reference tracking of an electrostatic micro-actuator with model uncertainty and external disturbances.

Other applications of H_∞ control include (Wang & Chen, 2006), where the non-minimum phase nature of the system was dealt with by shaping the reference trajectory using a causal inversion approach. The combination was shown, via simulation of a one-link flexible manipulator, to avoid the destabilising effect of having the sensor and controller spatially disparate.

Other non-model-based robust control approaches that have been suggested widely include sliding mode control. This control technique is robust to model uncertainty and insensitive to parameter variation. Sliding mode control has been widely applied for trajectory tracking in applications including robot manipulators (Slotine & Sastry, 1983), mobile robots (Yang & Kim, 1999) and electrical feed drives (Altintas, Erkorkmaz, & Zhu, 2000). The potential disadvantages of the technique include the possibility to induce chattering, and the need for a bounded disturbance model prior to controller development.

3.1.3. Implementation considerations

For the non-model-based algorithms discussed in the previous subsections, the design of a controller does not rely heavily on the existence of an explicit plant model. In the case of the robust algorithms, an approximate linear model with some knowledge of plant variability is typically enough to design the controllers.

Achieving a high level of performance using this class of algorithms through gain tuning can be challenging. Often heuristic approaches are employed in practice to balance the competing needs of robustness and performance, although some effort has been devoted to systematically approaching this problem (Åström, Panagopoulos, & Häggglund, 1998; Killingsworth & Krstic, 2006; Tan, Liu, Chen, & Marquez, 2006).

On the positive side, once designed the algorithms are readily implemented at high computation rates due to the relative simplicity of the associated control calculations. This has allowed them to be deployed for decades in industrial tracking applications with relatively low computation resources (e.g. position loop sample rates as high as 26 kHz for PID and H_∞ were used as far back as 1998 Steinbuch & Norg, 1998), or to increase the sampling rates to very high rates when more computational resources are available.

3.2. Disturbance-estimation-based feedback control

To compensate for the unknown disturbances arising from non-linear effects including friction, disturbance-estimation based methods have been widely proposed. Although a direct position measurement from the end-effector side is not generally available, vibration at the end effector induces oscillations in the motor current and position which can be measured. Whilst the filtering approaches of the previous section attempt to avoid excitation of vibrations, the disturbance estimation techniques instead try to actively compensate for any measured indications by modifying the current control input.

For disturbances that can be explicitly measured or modelled, feed-forward and feedback linearisation have been proposed to attenuate or eliminate the effect of disturbances (Aguilar-Avelar & Moreno-Valenzuela, 2016). Implementation of these techniques is typically not

undertaken in practice due to the difficulty and/or expense of the required direct measurements, and instead different types of disturbance-estimation-based control (DEBC) methods have been proposed. These approaches have been shown to preserve the nominal performance of the baseline controller in the absence of disturbance (Chen, Yang, Guo, & Li, 2016), which is advantageous from a controller tuning perspective.

Whilst many types of disturbance estimator have been proposed in the literature, herein their key features are summarised with a focus on the disturbance observer (DOB) and extended state observer (ESO) methods.

3.2.1. Disturbance-observer-based control

The disturbance observer was first proposed in 1983 for estimating the load torque in the speed control of a DC motor (Ohishi, Ohnishi, & Miyachi, 1983), under an implicit assumption that the load torque is constant. Since then, modifications to the original disturbance observer have been designed to enable application in a range of systems requiring disturbance suppression. These include extending the algorithm for the position loop in servo-motors (Huang et al., 2010; Kempf & Kobayashi, 1999; Ohishi, Ogino, & Hotta, 1989; Solsona, Valla, & Muravchik, 2000; Tan, Lee, Dou, Chin, & Zhao, 2003; Umeno & Hori, 1991), applications in X–Y tables (Jamaludin, Van Brussel, & Swevers, 2009; Lee & Tomizuka, 1996; Tan, Lim, Huang, Dou, & Giam, 2004), robotic manipulators (Eom, Suh, & Chung, 2001; Oh & Chung, 1999) and grinding circuit (Zhou, Dai, & Chai, 2014). An extensive review of disturbance estimation and attenuation techniques and their application in different domains was presented in Chen et al. (2016), although a direct comparison with other trajectory tracking methods was not considered.

The fundamental idea of DOB can be illustrated as shown in Fig. 4, where d_l is the lumped disturbance, and \hat{d} is the estimated lumped disturbance. If the mechanical subsystem from current to motor position can be represented by the transfer function $P(s)$, the DOB consists of an inverse of the nominal model $P_n^{-1}(s)$ and a low-pass filter $Q(s)$. Under the assumption that the time scale of the current loop is much faster than mechanical loop (implying $u \rightarrow u^* - \hat{d}$), and the subsystem from current to motor position is minimum phase, the lumped disturbance reduces to

$$d_l(s) = (P_n(s)^{-1} - P(s)^{-1})x_m(s) + d_l(s) + P_n(s)^{-1}d_m(s). \quad (3)$$

Now, if the filter is designed to have $Q(s) \approx 1$ within the desired operating frequency range of the closed loop, then $\hat{d} = d_l$. Then by substitution of (3) into the equation $x_m(s) = (u(s) + d_l(s))P(s)$, the output of the system can be shown to be

$$x_m(s) = P_n(s)u^*(s) - d_m(s). \quad (4)$$

Hence, the impact of the load disturbance d_l has been suppressed from the output, x_m by the DOB.

The efficacy of the approach is dependent on the linearity of the plant model, and subsequent design of the filter $Q(s)$. Furthermore, (4) deals only with the motor position and does not consider the end effector. There is no direct compensation for structural flexibility.

3.2.2. Extended state observer based control

The extended state observer (ESO) was first proposed in 1995 to estimate the lumped disturbance with incomplete information about the system dynamics (Han, 1995). Unlike many other methods, there is no reliance on linear plant assumptions. Typically, this observer is incorporated into the so-called active disturbance rejection control (ADRC) for reference tracking while reducing the effect caused by unknown disturbance (Han, 2009). The structure of the ESO-based reference tracking control scheme is shown in Fig. 5.

ESO observers have been successfully deployed in many industrial applications, usually in conjunction with ADRC, including mechatronics

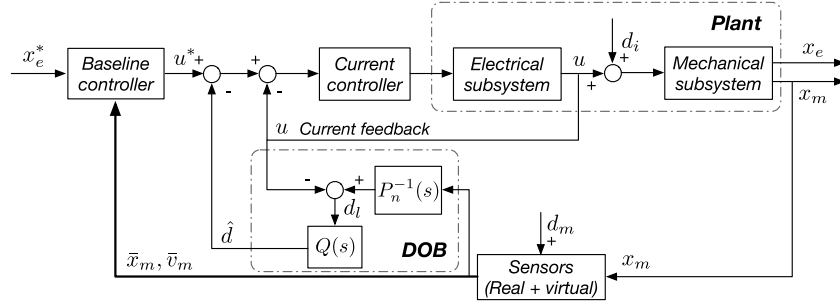

Fig. 4. Schematic diagram of DOB based reference tracking control scheme.

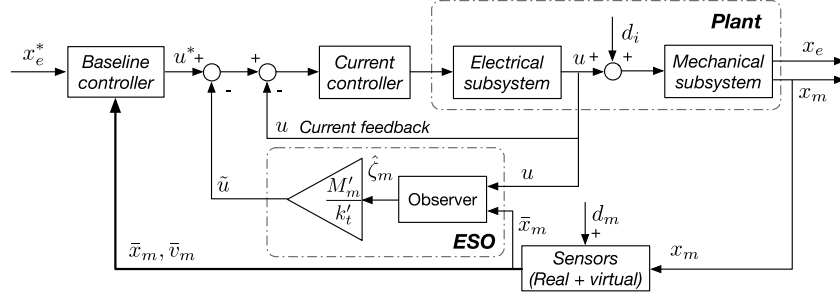

Fig. 5. Schematic diagram of ESO based reference tracking control scheme.

servo systems (Liu & Li, 2012; Sira-Ramirez, Linares-Flores, Garcia-Rodriguez, & Contreras-Ordaz, 2014; Su, Zheng, & Duan, 2005; Yao et al., 2014), robotic manipulators (Huang, Luo, Svinin, Odashima, & Hosoe, 2002; Su, Duan, Zheng, Zhang, Chen, & Mi, 2004; Talole, Kolhe, & Phadke, 2010) and power converters (Liu, Vazquez, Member, Wu, & Member, 2017; Sun & Gao, 2005; Yang, Wang, Wu, Li, & Li, 2015) for disturbance estimation and rejection. In addition to experimental results, the ESO-based approaches have been commercialised for industrial usage in systems such as the SpinTAC™ control software and motion control chip of Texas Instruments (Instruments Texas, 2014). Nonetheless, despite the wide deployment of the approach, fundamental theoretical results for the broad class of ESO algorithms lagged until 2011 (Guo & Zhao, 2011).

The structure of a typical ESO is reviewed in the following, under the assumption the mechanical system is a rigid structure. The mechanical subsystem (1) may be rewritten as:

$$\begin{aligned} \dot{x}_m &= v_m, \\ \dot{v}_m &= \frac{k'_t}{M'_m} u + \zeta_m, \end{aligned} \quad (5)$$

Here k'_t and M'_m are the nominal values of the force constant and actuator mass respectively; and $\zeta_m = \left(\frac{k_t}{M_m} - \frac{k'_t}{M'_m} \right) u - k_s (x_m - x_e) - c_s (v_m - v_e) - F_{d1}$ is the lumped disturbance including the model mismatch, the internal force introduced by the flexible component and external disturbances.

For a system in the form of (5), the ESO estimates ζ_m by introducing another state and applying error feedback on each stage as follows:

$$\begin{aligned} \dot{\hat{x}}_m &= \hat{v}_m + l_1 \Phi_1(\tilde{x}_m), \\ \dot{\hat{v}}_m &= \frac{k'_t}{M'_m} u + l_2 \Phi_2(\tilde{x}_m) + \hat{\zeta}_m, \\ \dot{\hat{\zeta}}_m &= l_3 \Phi_3(\tilde{x}_m), \end{aligned} \quad (6)$$

Here \hat{x}_m , \hat{v}_m and $\hat{\zeta}_m$ are the estimated value of x_m , v_m and ζ_m respectively; l_i is the gain of the observer to be chosen and $\Phi_i(\tilde{x}_m)$ is a function of estimation error with $\tilde{x}_m = \bar{x}_m - \hat{x}_m$ for $i = 1, 2, \dots, n+1$, where n is the order of mechanical subsystem, which is chosen to be $n = 2$ here according to (5).

Whilst many different ESO implementations have been considered, they may be broadly categorised as belonging to either linear ESO (LESO) or nonlinear ESO (NLESO) based on the choice of function $\Phi_i(\cdot)$.

The convergence and stability analysis of LESO, where $\Phi_i(\tilde{x}_m) = \tilde{x}_m$, was first provided in Zheng, Gaol, and Gao (2007) for an n -order single-input, single-output system with an integrator chain structure, under the assumption that all disturbances have bounded derivatives. Using the observer gain $l_i = \alpha_i \eta^{-i}$, where $\alpha_i = \frac{(n+1)!}{i!(n+1-i)!}$, $i = 1, 2, \dots, n+1$, the bandwidth of the observer $1/\eta$ becomes the only tuning parameter in the observer design.

In the LESO case, if $\dot{\zeta}_m$ is bounded, there exists an estimation error bound and a finite time T such that the estimator error of each states $|\tilde{x}_i(t)| \leq \mathcal{O}(\eta^k)$, $\forall t \geq T \geq 0$, $i = 1, \dots, n+1$ for a positive integer k . This result was later extended to include bounds on either the disturbance or its derivative (Yang & Huang, 2009).

To apply the ESO to nonlinear estimators, Han (2009) proposed specific heuristic structures for the nonlinear functions, $\Phi_i(\cdot)$. These NLESO algorithms have been widely used in many applications (Huang et al., 2002; Su et al., 2004; Su, Zheng, & Duan, 2005), although the nonlinear functions $\Phi_i(\cdot)$ were further generalised in Guo and Zhao (2011), where it was shown that they need only satisfy a converse Lyapunov theorem property. Under this assumption, the observer gain can be chosen as $l_i = \eta^{n-i}$ for $i = 1, 2, \dots, n+1$ and the estimation error on each state is bounded as $|\tilde{x}_i(t)| \leq \mathcal{O}(\eta^{n+2-i})$ for all $t \geq T \geq 0$ and $i = 1, \dots, n+1$. In practice, the NLESO errors are typically smaller than the corresponding errors observed using the LESO.

3.2.3. Implementation considerations

As an auxiliary control structure, the tuning of the disturbance estimation part should ensure that the convergence of disturbance estimation is much faster than the control loop where the observer located. For the disturbance-observer-based control, the selection of the nominal model P_n and the design of Q -filter determines the estimation accuracy of DOB. For the LESO case, since the function of estimation error $\Phi_i(\tilde{x}_m)$ is fixed, the tuning is relatively straightforward compared to NLESO as the choice of function $\Phi_i(\tilde{x}_m)$ offers more degrees of freedom in the design of the observer.

By directly estimating and compensating for external disturbances the approaches discussed in this subsection improve the robustness of

the system. However, a potential drawback of high-gain observers is the propensity to introduce a peaking phenomenon in the estimation error (Khalil, 2002). This was observed for the NLESO applied to velocity in Su, Zheng, Sun, and Duan (2005) as an initial sharp spike in the response of state estimation which may make the system unstable.

Furthermore, for a system with spatially separate motor and end effector, applying disturbance attenuation from the motor side can lead to inferior end-effector tracking performance. This explains why the disturbance estimation based methods are generally applied in combination with other methods such as command filtering for industrial applications.

From the perspective of computation effort, the disturbance estimation part is essentially another low order state-space model added to a baseline controller. As such it does not significantly increase the computation load relative to the baseline controller.

3.3. Model based control

The class of model-based controllers (MBC) rely on knowledge of the plant dynamics to achieve trajectory tracking. Therefore, system modelling and identification are essential for MBC (Hou & Wang, 2013). Depending on the type of control algorithm, models may also be required to capture uncertainty or disturbance levels in the control design.

In this section, we will distinguish between two types of model-based controllers on the basis of system constraints consideration — with the general class of unconstrained model-based controllers separated from those approaches explicitly encompassing constraints denoted model predictive control.

3.3.1. Unconstrained model-based control

Unconstrained model-based control covers a broad range of control architectures including state feedback control and linear quadratic (LQ) control for linear systems; through to Lyapunov-based control and feedback linearisation for nonlinear systems (Hou & Wang, 2013). Many of these approaches have been applied to industrial trajectory tracking for machines with structural flexibility as discussed below.

Pole-placement is a full state feedback control method that utilises a linear model of the mechanical system. Defining the state $x \triangleq [x_m \ v_m \ x_e \ v_e]^T$ and discretising the dynamics (1) and (2) leads to a representation in the form:

$$\begin{aligned} x(k+1) &= Ax(k) + Bu(k) + d_i(k), \\ y(k) &= Cx(k) + d_m(k). \end{aligned} \quad (7)$$

Assuming $d_i = d_m = 0$ the poles of the closed-loop system are assigned using $u = -Kx$ based on transient performance requirements. In Gordon and Erkorkmaz (2013), a pole-placement method was used to control the translational movement of a ball screw driven table. With the feedback from both the rotary motor and table side, the poles related to the axial mode are assigned to speed up the decay of vibration. A similar pole-placement based active damping method was used for the speed control of a two-mass drive system in Szabat and Orłowska-Kowalska (2007). It has been shown that with measurement of either shaft torque or load speed as the additional feedback for control, the desired damping coefficient or the resonant frequency can be adjusted. However, a major disadvantage of this approach is that the pole-placement method requires full state feedback, thereby necessitating observer design. Without observers, the additional measurements are difficult to obtain in a production environment and are therefore not widely implemented. Even with observers, pole placement control does not explicitly account for state constraints, so that subsequent careful tuning is required, particularly in systems with nonlinearities, to ensure the control signals are within the achievable domain for the entire operating envelope.

Linear quadratic control is another state feedback control method that uses the plant model (7) but assumes the noise processes d_i and

d_m are Gaussian with respective covariances W and V . The controller gain, K_{LQ} is designed based on an offline optimisation of a specified cost function of the form:

$$K_{LQ} = \arg \min_K \mathbb{E} \left[\|x(k)\|_Q^2 + \|u(k)\|_R^2 \right]$$

subject to (7) where \mathbb{E} is the expectation. For systems with unmeasurable states and additional system noise, as the problem investigated in this paper, the optimal regulator is combined with an optimal state observer to produce a linear quadratic Gaussian (LQG) approach. To implement this approach, quasi-steady states x_d and inputs u_d are calculated from a reference, x_e^* as follows,

$$\begin{bmatrix} A - I_4 & B \\ C & 0 \end{bmatrix} \begin{bmatrix} x_d \\ u_d \end{bmatrix} = \begin{bmatrix} 0_4 \\ x_e^* \end{bmatrix},$$

The estimated state $\hat{x}(k)$ is calculated based on a two-step (measurement and update) process according to:

$$\begin{aligned} \hat{x}(k) &= \bar{x}(k) + L(y(k) - C\bar{x}(k)), \\ \bar{x}(k+1) &= A\bar{x}(k) + Bu(k). \end{aligned}$$

The controller gain K_{LQ} and observer gain L can be calculated analytically (Suh, Chung, & Lee, 2001), leading to the control input $u(k) = -K_{LQ}(\hat{x}(k) - x_d(k)) + u_d(k)$.

Linear quadratic control has been used in applications including the tip positioning of a robot manipulator with flexible link (Morris & Madani, 1998) and speed control of an electric motor with flexible shaft (Carrière, Caux, & Fadel, 2010). The weightings of the cost function are adjusted to achieve a desired control performance such as improving accuracy (Bhat & Miu, 1990) or achieving energy minimisation (Carrière et al., 2010). The drawbacks of this approach include the number of tuning parameters for a n th-order system increasing from n in the pole placement case, to $n^2 + 1$ for LQ. Furthermore, any nonlinearities in the system are not explicitly considered or compensated, which may impact on potential tracking performance.

One approach to address this latter point involves using Lyapunov-based approaches that enable rigorous stability guarantees. The implementation of these approaches has been demonstrated in the position tracking control of a flexible-linked robot arm (Dadfarnia, Jalili, Xian, & Dawson, 2003; Tso, Yang, Xu, & Sun, 2003) and position tracking of electric motors (Makkar, Hu, Sawyer, & Dixon, 2007). To further improve tracking performance in the presence of parameter variations or slowly varying disturbances, Lyapunov-based methods may be augmented with other control methods such as adaptive control or integral feedback, e.g. Makkar et al. (2007). However, it is not trivial to find a Lyapunov candidate for designing this type of combined controller.

Instead of designing the controller based on the nonlinear dynamics of the system, feedback linearisation has been proposed to cancel out the nonlinearities in the system, enabling the deployment of algorithms for linear systems in the form of (7). For the tracking problem investigated in this paper, the feedback linearisation method has been utilised in numerous applications including decoupling the current and speed nonlinearities in electric drives (Bodson, Chiasson, Novotnak, & Rekowski, 1993) and cancelling out nonlinear dynamics of a flexible beam for tip position tracking (Castillo-Berrio & Feliu-Batlle, 2015). However, the successful implementation of feedback linearisation requires exact cancellation of nonlinearities which may be challenging in real scenarios.

In summary, we can see although some decent trajectory tracking results have been demonstrated by unconstrained model-based control, none of the control methods above explicitly take account of input, output and states constraints, and are reliant on the accuracy of the plant model.

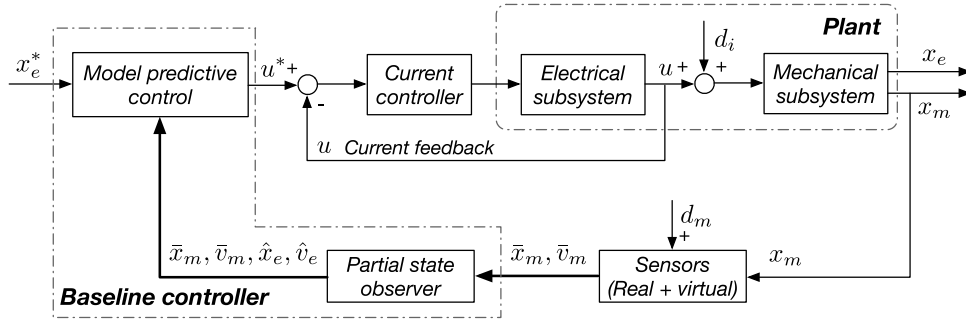

Fig. 6. Schematic diagram of MPC based reference tracking control scheme. Note that \hat{x}_e and \hat{v}_e stand for the estimated load position and velocity.

3.3.2. Model predictive control

Model predictive control (MPC) solves an online optimisation problem over a finite receding horizon with explicit consideration of system constraints (Maciejowski, 2002). Over the last 30 years, model predictive controllers have been gaining interest across a number of industrial domains as computational resources have advanced (Qin & Badgwell, 2003).

For systems with unmeasurable states, an observer is typically included leading to a control architecture as shown in Fig. 6. The MPC-based trajectory tracking problem involves solving the following constrained optimisation problem (where \mathcal{X} and \mathcal{U} represent the state and input constraint sets) at each sampling instant:

$$J = \min_{U_k} \sum_{i=0}^{N-1} \left(\|x_i - x_d\|_Q^2 + \|u_i - u_d\|_R^2 \right) + \|x_N - x_d\|_P^2 \quad (8)$$

$$s.t. \quad x_{i+1} = Ax_i + Bu_i, \quad (9)$$

$$x_i \in \mathcal{X}, u_i \in \mathcal{U}, i = 0, \dots, N-1, \quad (10)$$

$$x_0 = [\bar{x}_m^T(k), \bar{v}_m^T(k), \hat{x}_e^T(k), \hat{v}_e^T(k)]^T. \quad (11)$$

Note that the solution of this problem returns the control trajectory $U_k^* = [u_0^*, \dots, u_{N-1}^*]$ but only the first element u_0^* is imposed on plant. Ensuring feasibility of the optimisation problem above, and the stability of the closed-loop system under the control are two of the fundamental aspects of predictive control design.

An early contribution in the application of predictive control to motion control of feed drives was made in 1990 via a combination of cascade control structure with generalised predictive control (GPC) (Boucher, Dumur, & Rahmani, 1990). Although the idea of including system dynamics (9) and receding horizon with update (11) were shown in this early work, the state and input constraints (10) were not considered. Later, this initial work was extended to handle changing plant parameters such as variation of inertia (Dumur, Boucher, & Ramond, 2000), by updating the system model online based on observed errors.

To solve the tracking problem (8)–(11) with constraints while ensuring recursive feasibility of the open-loop optimisation problem, a command governor was introduced by Gilbert, Kolmanovsky, and Tan (1994) to modify the reference and ensure an admissible solution exists. Similar ideas were expanded in Garone, Di Cairano, and Kolmanovsky (2017). As an alternative, in Chisci and Zappa (2003), a dual-mode predictive control strategy is proposed where a feasibility recovery mode operates to recover feasibility should it be lost. These approaches were given a theoretical footing by introducing an artificial steady state and input as decision variables in the problem formulation (8), leading to a modified control algorithm with provable guarantees for piecewise constant reference tracking (Limon, Alvarado, Alamo, & Camacho, 2008). This was further extended to allow offset-free reference tracking with explicit consideration of disturbances in the system dynamics (Maeder & Morari, 2010).

However, achieving asymptotically offset-free tracking for a disturbance-free system is not enough in many practical implementations. For applications such as laser cutting, it is highly desirable that

the contouring error or the tracking error of each axis is within some desired tolerance. In Di Cairano and Borrelli (2016), an error-bounded tracking controller is designed for a linear time-invariant (LTI) system by modifying (10) such that the system states stay within a robust control invariant (RCI) set. The existence of the offline-computed RCI set indicates that the error bound can be guaranteed for particular classes of reference and system with consideration of state and input constraints. However, the RCI set may not be finitely determined for systems with state disturbances (Blanchini, 1999; Rakovic, Kerrigan, Mayne, & Lygeros, 2006; Runger & Tabuada, 2017), making it non-trivial to be computed for practical implementation. This motivated the development of a finite-step RCI set estimation algorithm for error bounded tracking control (Yuan, Manzie, Good, Shames, Gan, et al., 2019). The algorithm was validated in the simulation and experiment for machines with structural flexibility.

3.3.3. Implementation considerations

Since model-based controllers are designed and implemented based on the system model dynamics, the accuracy of the model influences the control performance. This can be direct, through the reliance on the model in the generation of the control signals, or indirect in the case of approaches which remain robust to specified model inaccuracy. To achieve a good control performance typically requires effort to be spent on the system identification process.

For model-based controllers, the control performance in terms of accuracy is often reported to be superior to non-model-based methods, which is not surprising as the knowledge of the system dynamics is used constructively in the controller. However, better performance always comes with a higher commissioning effort. For instance in LQ control described above, the tuning parameters in the matrices Q and R increase polynomially with the number of states and inputs; and these parameters may not be explicitly related to the time domain responses. This can lead to more challenging commissioning compared to non-model based schemes, especially when there is a lack of systematic tuning criteria.

In terms of the embedded computation, the computational load of model-based control methods is generally higher than a comparable non-model-based controller. Methods such as pole-placement and an LQ-based controller are essentially control algorithms reliant on off-line computed state feedback gains and so have a relatively low computational burden. In fixed-point microcontrollers, this may be increased if the feedback linearisation involves certain types of functions - e.g. exponentials.

On the other hand, the online solution of a constrained optimisation problem in MPC can be challenging computationally even for relatively straightforward system dynamics depending on the computational resource available. The growing interest in these algorithms is being driven by their potential capabilities in reference tracking and constraint satisfaction, yet the computation requirements in fast sample rate applications remain challenging. For those MPC variations with additional constraints, such as the error-bounded MPC mentioned

Table 1
Comparison of investigated tracking control algorithms.

Control approach	Tracking performance	Robustness	Complexity	Implementation effort
PID-based cascaded control				
Standard cascaded control	1-2	2-3	1-2	3-4
PID with additional sensing	2-3	2-3	1-2	3-5
PID with filtering	2-3	1-2	1-2	3-5
Non-model-based robust control				
H_∞ control	2-3	4-5	2-3	3-4
Sliding mode control	2-3	3-4	2-3	2-3
Disturbance-estimation-based feedback control				
DOB based control	2-3	2-3	1-2	2-3
LESO based control	2-3	3-4	2-3	2-3
NLESO based control	2-4	3-4	3-4	3-4
Unconstrained model-based control				
Pole placement	2-3	1-2	1-2	2-3
Linear quadratic control	2-3	2-3	2-4	2-3
Lyapunov-based approach	2-4	2-3	3-4	3-4
Feedback linearisation	3-4	1-2	3-4	3-5
Model predictive control				
Standard tracking MPC	3-4	2-3	4-5	4-5
Error bounded MPC	3-5	4-5	4-5	4-5

Note: the controllers are compared in different aspects under levels from Low (1) to High (5).

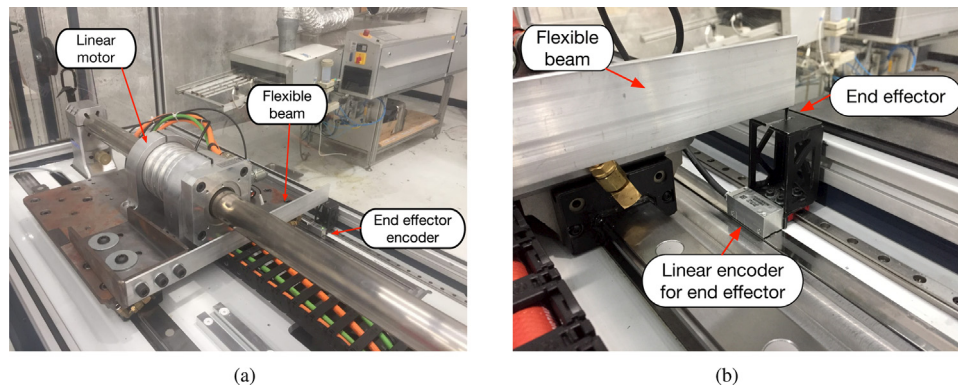

Fig. 7. Designed test bench: (a) linear motor with flexible structure; (b) end-effector measurement.

above, an extra commissioning effort is required to compute the required disturbance sets, and the additional inequalities introduced may pose further challenges in terms of on-line computation on embedded industrial platforms.

3.4. Qualitative comparison

The discussion in Sections 3.1–3.3 is qualitatively summarised in Table 1.

4. Experimental comparison of algorithms

One of the challenges in assessing the existing methods in the literature is the lack of a uniform platform on which to compare results. In this section, a single axis test bench representing the dynamics (1) and (2) is proposed and representative controllers from the above literature review are tuned and implemented.

The test bench replicates key features of an industrial system including structural flexibility, external disturbances and spatially separate motor and end effector. The chosen control algorithms include a standard cascaded controller; a cascaded controller with notch filter; a cascaded controller with LESO; and an error-bounded model predictive controller.

4.1. Experimental set-up

The test bench consists of a linear motor and a flexible beam, where the end effector lies at the end of the beam furthest from the motor as shown in Fig. 7(a). The LinX[®] S-series linear motor designed by ANCA Motion is a permanent magnet synchronous tubular motor with high acceleration and high-resolution position measurement. An aluminium flexible beam is attached on the motor base and stretches out in the direction perpendicular to the movement direction of the base.

For quantitative tracking performance comparison, another linear encoder is installed at the end of the flexible beam for end-effector position measurement as shown in Fig. 7(b). The measured end-effector position is not used in the controller design process and is only for documenting experiment results. This second encoder is installed on a linear slide to measure the end-effector movement parallel to the motor base. The friction introduced by the linear slide will have a detrimental influence on the end-effector tracking performance.

The characteristics of the beam and end-effector bracket are carefully designed to ensure the dominant resonant frequency lies within the closed-loop bandwidth of the general cascaded controller. The low-order dynamics of the test bench are described by (1), (2).

The entire experiment setup is shown in Fig. 8 where the Simulink Real-Time is used as the rapid prototyping system. The compiled controller is downloaded from the development computer onto the embedded target computer AMC5, which is a commercial off-the-shelf device

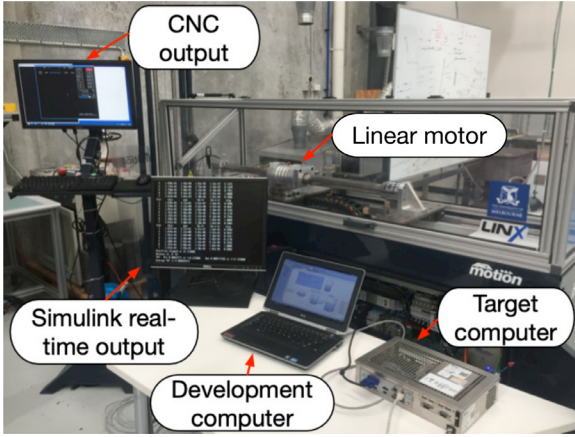

Fig. 8. Overview of the entire experiment setup.

utilising an i7 2.3 GHz processor (ANCA Motion, 2019), for real-time implementation. The communication rate between the target computer and test bench drive is 1 kHz and the digital controller updates at the same rate for all the investigated control algorithms.

In a production environment, further code optimisation should enable implementation at the drive level of all trialled control architectures.

4.2. Desired trajectory

The generation of reference trajectory involves a path planner that typically incorporates a model of the system and constraints into an offline optimisation problem. This is an active field of research in its own right (Betts, 1998; Chettibi, Lehtihet, Haddad, & Hanchi, 2004), but is not a focus of this review. Instead, to maintain a straightforward quantitative analysis, only ramps and sinusoidal references are considered in the experiments. These are often part of real trajectories in industrial motion control problems, and hence are reasonable bases for comparison.

To evaluate the tracking performance of the controllers, two widely used trajectory-tracking tasks were considered. In Task A, we require the load to conduct a point-to-point (PTP) movement for 0.1 m distance with maximum velocity 0.1 m/s and maximum acceleration 4 m/s². For Task B, a sinusoidal reference trajectory $x_e^*(t) = 0.05 \cos(2t) + 0.05$ is used for reference tracking. A 0.1 s waiting time at the beginning of each trajectory is included in both references.

4.3. Tuning of the controllers

Throughout this work, in keeping with most production scenarios, it is assumed that the position measurement of end effector is not available when designing the controllers and is only used to demonstrate the tracking performance.

To develop a system model for tuning and simulation purpose, the friction and cogging force are identified using the procedure outlined in Yuan, Manzie, Good, Shames, Gan, et al. (2019), Yuan, Manzie, Good, Shames, Keynejad, et al. (2019) to approximate the disturbance F_{d1} . The high-fidelity model is then used to tune the gains of the cascaded controller, both without and with a notch filter to improve the actuator-side tracking accuracy.

The identification of a system model is beneficial for all controller types. In the case of non-model-based architectures, it may be used for offline tuning using a digital twin. Naturally, the model-based approaches require a model during online implementation. The commissioning of appropriate models should be considered as part of the implementation cost in all cases.

The cascaded controller consists of a P controller with proportional gain $k_{pp} = 30$ 1/s as the position controller, a PI controller with proportional gain $k_{pv} = 55.67$ As/m, and time constant $T_{iv} = 0.04$ s as the velocity controller. The current controller is implemented at the drive level and is not considered in the controller design due to its fast time scale. The instantaneous transfer function of the notch filter is given as

$$N_f(s) = \frac{s^2 + 2g\zeta\omega s + \omega^2}{s^2 + 2\zeta\omega s + \omega^2}, \quad (12)$$

where the gain of notch filter g and the damping ratio of the filter ζ are tuned to be 0.85 and 0.05. The value of the notch frequency ω is chosen as 87 rad/s to reduce the amplitude of the damped natural frequency present in the rig.

For the cascaded controller with LESO, we used the same tuning parameters for the baseline controller and tuned the observer bandwidth $1/\eta$ as 700 rad/s to ensure a fast convergence of estimated states.

The error-bounded MPC is designed using a cost function $J = 10^6(x_{e(i)}^* - \hat{x}_{e(i)})^2 + 0.4u_i^2$. The tracking error bound between the estimated end-effector position and reference $\|x_e^* - \hat{x}_e\|_\infty \leq 4.5$ mm is used to compute an RCI set such that $\|x_e^* - x_e\|_\infty \leq 5$ mm can be guaranteed.

4.4. Performance comparison

The actuator and load-side trajectory performance for the point-to-point (Task A) and sinusoidal (Task B) movement are demonstrated in Figs. 9 and 11, with the corresponding tracking error given in Figs. 10 and 12. In general, it can be seen that the flexible linkage amplifies the vibration at the end-effector side relative to the motor oscillations. Anecdotally, this phenomenon is consistent with observations in production machines where good motor tracking can still result in poor tolerancing at the end effector.

To quantitatively analyse the tracking performance of the tasks using the different controllers, a number of performance metrics are considered. As there is an implicit zero vibration assumption in most of the control architectures (i.e. the link between the end effector and the motor is assumed rigid), the difference between the motor position and the end effector reference $|x_m - x_e^*|$ indicates the typical error available for feedback in a production machine. The output quality is however better indicated by the error between the end effector and the reference, $|x_e - x_e^*|$. The maximum deformation in the rigid link is calculated as $\|x_m - x_e\|_\infty$. This indicates the lateral vibration magnitude and stress on the mechanism, which ideally should be kept low. The mean absolute value of current input is used as an indicator of the control effort and the implementation cost is characterised by the average computation time per sampling period. These metrics are captured for the two tasks in Tables 2 and 3.

If we first consider the tracking trajectory results for the cascaded PI structures, from Fig. 9 to Fig. 11, it can be seen that there is more vibration at the load side than the motor side. Quantitatively, the additional filter provides only marginal improvements in most performance metrics for two tasks although the maximum deformation across the beam is reduced by approximately 11% in Task A and 33% in Task B.

If the cascaded PI is instead augmented with the LESO, the motor side performance is improved in terms of both the maximum and average tracking error aspect in Task A. However, the inclusion of LESO deteriorates the tracking accuracy in Task B for both actuator and end-effector side as seen in Fig. 11 and Table 3. This is again commonly observed in the industry where better actuator-side performance achieved may lead to a worse machining result. In practice, this leads to LESO often being combined with other augmentations (such as notch filtering) to provide improved tracking results with vibration attenuation.

Finally, the implemented MPC algorithm can be observed to achieve the best tracking performance on both the actuator and load sides,

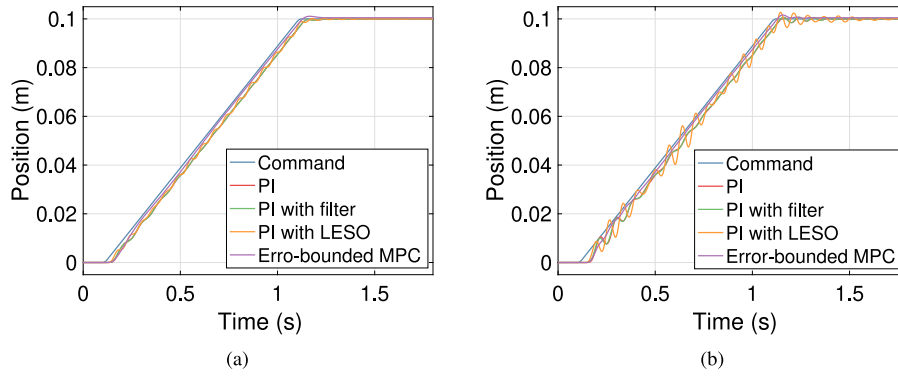

Fig. 9. Actuator (a) and load-side (b) position measurement of point-to-point movement.

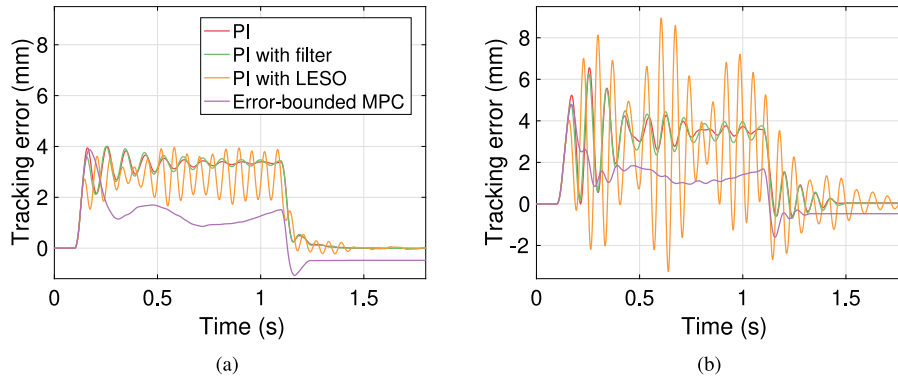

Fig. 10. Actuator (a) and load-side (b) trajectory tracking error of point-to-point movement.

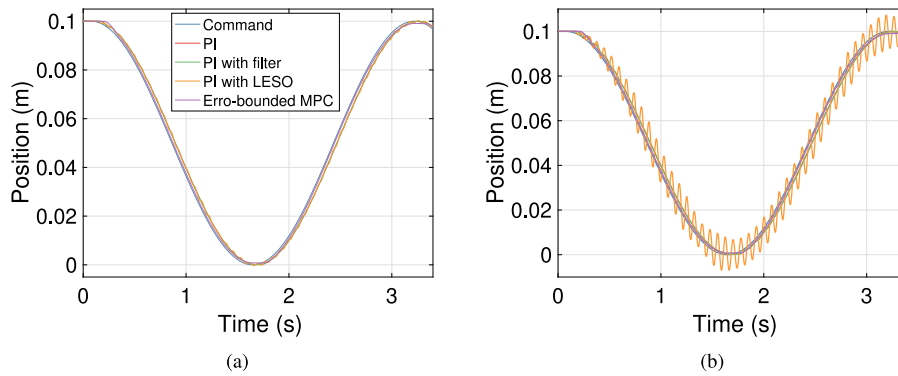

Fig. 11. Actuator (a) and load-side (b) position measurement of sinusoidal movement.

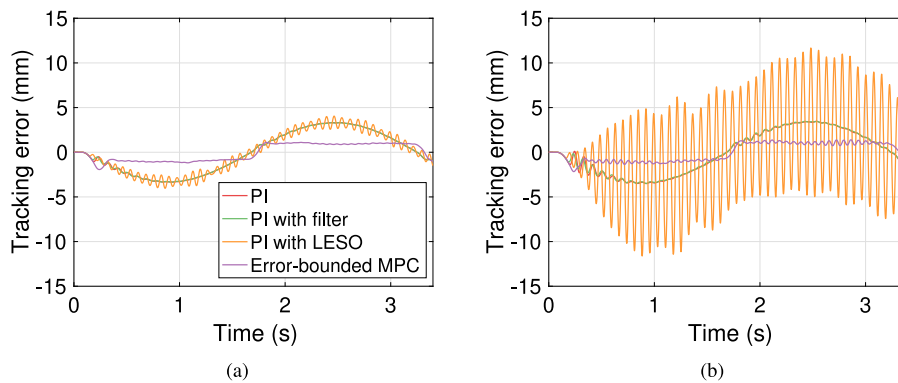

Fig. 12. Actuator (a) and load-side (b) trajectory tracking error of sinusoidal movement.

Table 2
Task A performance comparison.

Controller	$ x_m - x_e^* $ (mm)		$ x_e - x_e^* $ (mm)		$ x_m - x_e $ (mm)	Control effort (A)	Computation time (ms)
	Max	Mean	Max	Mean			
Cascaded PI	4.002	1.603	6.556	1.722	2.556	0.744	0.026
Cascaded PI with filter	4.001	1.596	6.271	1.695	2.272	0.707	0.028
Cascaded PI with LESO	3.963	1.379	8.953	1.823	6.910	1.743	0.027
Error bounded MPC	3.876	0.939	4.782	0.997	0.908	0.415	0.297

Table 3
Task B performance comparison.

Controller	$ x_m - x_e^* $ (mm)		$ x_e - x_e^* $ (mm)		$ x_m - x_e $ (mm)	Control effort (A)	Computation time (ms)
	Max	Mean	Max	Mean			
Cascaded PI	3.358	1.975	3.552	2.053	0.830	0.595	0.0115
Cascaded PI with filter	3.344	1.968	3.535	2.043	0.551	0.553	0.0118
Cascaded PI with LESO	4.044	1.969	11.758	4.394	9.105	2.118	0.0117
Error bounded MPC	1.934	0.906	2.124	0.965	0.861	0.553	0.2986

courtesy of the flexible linkage plant model being explicitly considered in the controller. This also leads to lower effort on behalf of the controller, as it does not have to work against the induced vibrations in a feedback sense. Moreover, the load-side maximum tracking error is guaranteed within the desired tolerance of 5 mm, which validates the efficacy of the error-bounded tracking design. However, to achieve this enhanced tracking performance comes at the cost of a significant increase in computational burden. As demonstrated in Tables 2 and 3, this can stretch from 10 to 30 times that required by the other traditional algorithms.

5. Conclusion

Systems with features such as structural flexibility, external disturbances and spatially separate actuator and end effector are common in industrial applications, which makes the trajectory tracking problem challenging. The desire to improve manufacturing accuracy and throughput inspires the development of different control algorithms. In this paper, a review and survey are conducted on several widely used trajectory tracking methods and experimental results on a hardware platform are shown to demonstrate the performance of the different control methodologies quantitatively.

Declaration of competing interest

The authors declare that they have no known competing financial interests or personal relationships that could have appeared to influence the work reported in this paper.

References

- Åström, K., Panagopoulos, H., & Häggglund, T. (1998). Design of PI controllers based on non-convex optimization. *Automatica*, 34(5), 585–601. [http://dx.doi.org/10.1016/S0005-1098\(98\)00011-9](http://dx.doi.org/10.1016/S0005-1098(98)00011-9).
- Aguilar-Avelar, C., & Moreno-Valenzuela, J. (2016). New feedback linearisation based control for arm trajectory tracking of the furuta pendulum. *IEEE/ASME Transactions on Mechatronics*, 21(2), 638–648. <http://dx.doi.org/10.1109/TMECH.2015.2485942>.
- Altintas, Y., Erkorkmaz, K., & Zhu, W.-H. (2000). Sliding mode controller design for high speed feed drives. *CIRP Annals*, 49(1), 265–270. [http://dx.doi.org/10.1016/S0007-8506\(07\)62943-6](http://dx.doi.org/10.1016/S0007-8506(07)62943-6).
- Amann, N., Owens, D. H., Rogers, E., & Wahl, A. (1996). An H_∞ approach to linear iterative learning control design. *International Journal of Adaptive Control and Signal Processing*, 10, 767–781. [http://dx.doi.org/10.1002/\(SICI\)1099-1115\(199611\)10:6<767::AID-ACS420>3.0.CO;2-L](http://dx.doi.org/10.1002/(SICI)1099-1115(199611)10:6<767::AID-ACS420>3.0.CO;2-L).
- ANCA Motion (2019). AMCS CNC. URL <https://motion.anca.com/Products/CNC/CNC/AMCS>.
- Bahn, W., Kim, T. I., Lee, S. H., & Cho, D. I. D. (2017). Resonant frequency estimation for adaptive notch filters in industrial servo systems. *Mechatronics*, 41, 45–57. <http://dx.doi.org/10.1016/j.mechatronics.2016.11.004>.

- Benosman, M., & Le Vey, G. (2004). Control of flexible manipulators: a survey. *Robotica*, 22(5), 533–545. <http://dx.doi.org/10.1017/S0263574703005642>.
- Betts, J. T. (1998). Survey of numerical methods for trajectory optimization. *Journal of Guidance, Control and Dynamics*, 21(2), 193–207. <http://dx.doi.org/10.2514/2.4231>.
- Bhat, S. P., & Miu, D. K. (1990). Precise point-to-point positioning control of flexible structures. *Journal of Dynamic Systems, Measurement, and Control*, 112(4), 667–674. <http://dx.doi.org/10.1115/1.2896193>.
- Blanchini, F. (1999). Set invariance in control. *Automatica*, 35(11), 1747–1767. [http://dx.doi.org/10.1016/S0005-1098\(99\)00113-2](http://dx.doi.org/10.1016/S0005-1098(99)00113-2).
- Bodson, M., Chiasson, J., Novotnak, R., & Rekowski, R. (1993). High-performance nonlinear feedback control of a permanent magnet stepper motor. *IEEE Transactions on Control Systems Technology*, 1(1), 5–14. <http://dx.doi.org/10.1109/87.221347>.
- Bonivento, C., Nersisian, A., & Zanasi, R. (1994). A cascade structure for robust control design. *IEEE Transactions on Automatic Control*, 39(4), 846–849. <http://dx.doi.org/10.1109/9.286267>.
- Boucher, P., Dumur, D., & Rahmani, K. F. (1990). Generalized predictive cascade control (GPCC) for machine tools drives. *CIRP Annals*, 39(1), 357–360. [http://dx.doi.org/10.1016/S0007-8506\(07\)61072-5](http://dx.doi.org/10.1016/S0007-8506(07)61072-5).
- Buja, G., & Kazmierkowski, M. (2004). Direct torque control of PWM inverter-fed AC motors - a survey. *IEEE Transactions on Industrial Electronics*, 51(4), 744–757. <http://dx.doi.org/10.1109/TIE.2004.831717>.
- Cannon, R. H., & Schmitz, E. (1984). Initial experiments on the end-point control of a flexible one-link robot. *International Journal of Robotics Research*, 3(3), 62–75. <http://dx.doi.org/10.1177/027836498400300303>.
- Carrière, S., Caux, S., & Fadel, M. (2010). Optimised speed control in state space for PMSM direct drives. *IET Electric Power Applications*, 4(3), 158–168. <http://dx.doi.org/10.1049/iet-epa.2009.0080>.
- Castillo-Berrio, C. F., & Feliu-Batlle, V. (2015). Vibration-free position control for a two degrees of freedom flexible-beam sensor. *Mechatronics*, 27, 1–12. <http://dx.doi.org/10.1016/j.mechatronics.2015.01.005>.
- Chen, W. H., Yang, J., Guo, L., & Li, S. (2016). Disturbance-observer-based control and related methods - an overview. *IEEE Transactions on Industrial Electronics*, 63(2), 1083–1095. <http://dx.doi.org/10.1109/TIE.2015.2478397>.
- Chen, Z., Yao, B., & Wang, Q. (2013a). Accurate motion control of linear motors with adaptive robust compensation of nonlinear electromagnetic field effect. *IEEE/ASME Transactions on Mechatronics*, 18(3), 1122–1129. <http://dx.doi.org/10.1109/TMECH.2012.2197217>.
- Chen, Z., Yao, B., & Wang, Q. (2013b). Adaptive robust precision motion control of linear motors with integrated compensation of nonlinearities and bearing flexible modes. *IEEE Transactions on Industrial Informatics*, 9(2), 965–973. <http://dx.doi.org/10.1109/TII.2012.2225439>.
- Chettibi, T., Lehtihet, H. E., Haddad, M., & Hanchi, S. (2004). Minimum cost trajectory planning for industrial robots. *European Journal of Mechanics, A/Solids*, 23(4), 703–715. <http://dx.doi.org/10.1016/j.euromechsol.2004.02.006>.
- Chisci, L., & Zappa, G. (2003). Dual mode predictive tracking of piecewise constant references for constrained linear systems. *International Journal of Control*, 76(1), 61–72. <http://dx.doi.org/10.1080/0020717021000049160>.
- Cychowski, M., Szabat, K., & Orłowska-Kowalska, T. (2009). Constrained model predictive control of the drive system with mechanical elasticity. *IEEE Transactions on Industrial Electronics*, 56(6), 1963–1973. <http://dx.doi.org/10.1109/TIE.2009.2015753>.
- Dadfarinia, M., Jalili, N., Xian, B., & Dawson, D. (2003). Lyapunov-based piezoelectric control of flexible cartesian robot manipulators. In *Proceedings of the 2003 American control conference, 2003* (pp. 5227–5232). IEEE, <http://dx.doi.org/10.1109/ACC.2003.1242557>.

- Di Cairano, S., & Borrelli, F. (2016). Reference tracking with guaranteed error bound for constrained linear systems. *IEEE Transactions on Automatic Control*, 61(8), 2245–2250. <http://dx.doi.org/10.1109/TAC.2015.2491738>.
- Dumur, D., Boucher, P., & Ramond, G. (2000). Direct adaptive generalized predictive control. application to motor drives with flexible modes. *CIRP Annals*, 49(1), 271–274. [http://dx.doi.org/10.1016/S0007-8506\(07\)62944-8](http://dx.doi.org/10.1016/S0007-8506(07)62944-8).
- Dwivedy, S. K., & Eberhard, P. (2006). Dynamic analysis of flexible manipulators, a literature review. *Mechanism and Machine Theory*, 41(7), 749–777. <http://dx.doi.org/10.1016/j.mechmachtheory.2006.01.014>.
- Eom, K. S., Suh, I. H., & Chung, W. K. (2001). Disturbance observer based path tracking control of robot manipulator considering torque saturation. *Mechatronics*, 11(3), 325–343. [http://dx.doi.org/10.1016/S0957-4158\(00\)00021-0](http://dx.doi.org/10.1016/S0957-4158(00)00021-0).
- Erkorkmaz, K., & Altintas, Y. (2001). High speed CNC system design. Part III: high speed tracking and contouring control of feed drives. *International Journal of Machine Tools and Manufacture*, 41(11), 1637–1658. [http://dx.doi.org/10.1016/S0890-6955\(01\)00004-9](http://dx.doi.org/10.1016/S0890-6955(01)00004-9).
- Erkorkmaz, K., & Hosseinkhani, Y. (2013). Control of ball screw drives based on disturbance response optimization. *CIRP Annals - Manufacturing Technology*, 62(1), 387–390. <http://dx.doi.org/10.1016/j.cirp.2013.03.138>.
- Fuentes, E. J., Silva, C. A., & Yuz, J. I. (2012). Predictive speed control of a two-mass system driven by a permanent magnet synchronous motor. *IEEE Transactions on Industrial Electronics*, 59(7), 2840–2848. <http://dx.doi.org/10.1109/TIE.2011.2158767>.
- Garone, E., Di Cairano, S., & Kolmanovsky, I. (2017). Reference and command governors for systems with constraints: a survey on theory and applications. *Automatica*, 75, 306–328. <http://dx.doi.org/10.1016/j.automatica.2016.08.013>.
- Garpinger, O., Häggglund, T., & Åström, K. J. (2014). Performance and robustness trade-offs in PID control. *Journal of Process Control*, 24(5), 568–577. <http://dx.doi.org/10.1016/j.jprocont.2014.02.020>.
- Ge, S., Lee, T., & Zhu, G. (1997). Non-model-based position control of a planar multi-link flexible robot. *Mechanical Systems and Signal Processing*, 11(5), 707–724. <http://dx.doi.org/10.1006/mssp.1997.0107>.
- Gilbert, E., Kolmanovsky, I., & Tan, K. (1994). Nonlinear control of discrete-time linear systems with state and control constraints: a reference governor with global convergence properties. In *Proceedings of 1994 33rd IEEE conference on decision and control (vol. 1)* (pp. 144–149). IEEE, <http://dx.doi.org/10.1109/CDC.1994.411031>.
- Goodwin, G., Graebe, S., & Salgado, M. (2000). *Control system design*. Prentice Hall.
- Gordon, D. J., & Erkorkmaz, K. (2012). Precision control of a T-type gantry using sensor/actuator averaging and active vibration damping. *Precision Engineering*, 36(2), 299–314. <http://dx.doi.org/10.1016/j.precisioneng.2011.11.003>.
- Gordon, D. J., & Erkorkmaz, K. (2013). Accurate control of ball screw drives using pole-placement vibration damping and a novel trajectory prefilter. *Precision Engineering*, 37(2), 308–322. <http://dx.doi.org/10.1016/j.precisioneng.2012.09.009>.
- Guo, B., & Zhao, Z. (2011). On the convergence of an extended state observer for nonlinear systems with uncertainty. *Systems & Control Letters*, 60(6), 420–430. <http://dx.doi.org/10.1016/j.sysconle.2011.03.008>.
- Hace, A., Jezernik, K., & Šabanović, A. (2007). SMC with disturbance observer for a linear belt drive. *IEEE Transactions on Industrial Electronics*, 54(6), 3402–3412. <http://dx.doi.org/10.1109/TIE.2007.906130>.
- Han, J. (1995). The extended state observer of a class of uncertain systems. *Chinese, Control and Decision*, 10(1), 85–88. <http://dx.doi.org/10.13195/j.cd.1995.01.85.hanjq.020>.
- Han, J. (2009). From PID to active disturbance rejection control. *IEEE Transactions on Industrial Electronics*, 56(3), 900–906. <http://dx.doi.org/10.1109/TIE.2008.2011621>.
- Hanifzadegan, M., & Nagamune, R. (2015). Tracking and structural vibration control of flexible ball-screw drives with dynamic variations. *IEEE/ASME Transactions on Mechatronics*, 20(1), 133–142. <http://dx.doi.org/10.1109/TMECH.2014.2298241>.
- Hou, Z. S., & Wang, Z. (2013). From model-based control to data-driven control: survey, classification and perspective. *Information Sciences*, 235, 3–35. <http://dx.doi.org/10.1016/j.ins.2012.07.014>.
- Huang, W.-S., Liu, C.-W., Hsu, P.-L., & Yeh, S.-S. (2010). Precision control and compensation of servomotors and machine tools via the disturbance observer. *IEEE Transactions on Industrial Electronics*, 57(1), 420–429. <http://dx.doi.org/10.1109/TIE.2009.2034178>.
- Huang, Y., Luo, Z., Svinin, M., Odashima, T., & Hosoe, S. (2002). Extended state observer based technique for control of robot systems. In *Proceedings of the 4th world congress on intelligent control and automation (vol. 4)* (pp. 2807–2811). IEEE, <http://dx.doi.org/10.1109/WCICA.2002.1020036>.
- Instruments Texas (2014). TMS320F28069M, TMS320F28068M InstaSPIN™-MOTION software technical reference manual. Dallas, Texas. URL <http://www.ti.com/lit/ug/spruhj0b/spruhj0b.pdf>.
- Jamaludin, Z., Van Brussel, H., & Swevers, J. (2009). Friction compensation of an XY feed table using friction-model-based feedforward and an inverse-model-based disturbance observer. *IEEE Transactions on Industrial Electronics*, 56(10), 3848–3853. <http://dx.doi.org/10.1109/TIE.2009.2017560>.
- Kempf, C., & Kobayashi, S. (1999). Disturbance observer and feedforward design for a high-speed direct-drive positioning table. *IEEE Transactions on Control Systems Technology*, 7(5), 513–526. <http://dx.doi.org/10.1109/87.784416>.
- Khalil, H. K. (2002). *Nonlinear systems* (3rd ed.). Pearson.
- Kiang, C. T., Spowage, A., & Yoong, C. K. (2015). Review of control and sensor system of flexible manipulator. *Journal of Intelligent & Robotic Systems*, 77(1), 187–213. <http://dx.doi.org/10.1007/s10846-014-0071-4>.
- Killingsworth, N. J., & Krstic, M. (2006). PID tuning using extremum seeking: online, model-free performance optimization. *IEEE Control Systems*, 26(1), 70–79. <http://dx.doi.org/10.1109/MCS.2006.1580155>.
- Lee, D.-H., Lee, J., & Ahn, J.-W. (2012). Mechanical vibration reduction control of two-mass permanent magnet synchronous motor using adaptive notch filter with fast fourier transform analysis. *IET Electric Power Applications*, 6(7), 455. <http://dx.doi.org/10.1049/iet-epa.2011.0322>.
- Lee, H. S., & Tomizuka, M. (1996). Robust motion controller design for high-accuracy positioning systems. *IEEE Transactions on Industrial Electronics*, 43(1), 48–55. <http://dx.doi.org/10.1109/41.481407>.
- Li, Y., & Chen, X. (2001). End-point sensing and state observation of a flexible-link robot. *IEEE/ASME Transactions on Mechatronics*, 6(3), 351–356. <http://dx.doi.org/10.1109/3516.951373>.
- Li, W., & Liu, P. X. (2009). Robust adaptive tracking control of uncertain electrostatic micro-actuators with H-infinity performance. *Mechatronics*, 19(5), 591–597. <http://dx.doi.org/10.1016/j.mechatronics.2009.01.006>.
- Li, S., Xia, C., & Zhou, X. (2012). Disturbance rejection control method for permanent magnet synchronous motor speed-regulation system. *Mechatronics*, 22(6), 706–714. <http://dx.doi.org/10.1016/j.mechatronics.2012.02.007>.
- Limon, D., Alvarado, I., Alamo, T., & Camacho, E. (2008). MPC for tracking piecewise constant references for constrained linear systems. *Automatica*, 44(9), 2382–2387. <http://dx.doi.org/10.1016/j.automatica.2008.01.023>.
- Liu, H., & Li, S. (2012). Speed control for PMSM servo system using predictive functional control and extended state observer. *IEEE Transactions on Industrial Electronics*, 59(2), 1171–1183. <http://dx.doi.org/10.1109/TIE.2011.2162217>.
- Liu, Z., Luo, F., & Rahman, M. (2005). Robust and precision motion control system of linear-motor direct drive for high-speed X-Y table positioning mechanism. *IEEE Transactions on Industrial Electronics*, 52(5), 1357–1363. <http://dx.doi.org/10.1109/TIE.2005.855661>.
- Liu, J., Vazquez, S., Member, S., Wu, L., & Member, S. (2017). Extended state observer-based sliding-mode control for three-phase power converters. *IEEE Transactions on Industrial Electronics*, 64(1), 22–31. <http://dx.doi.org/10.1109/TIE.2016.2610400>.
- Lochan, K., Roy, B., & Subudhi, B. (2016). A review on two-link flexible manipulators. *Annual Reviews in Control*, 42, 346–367. <http://dx.doi.org/10.1016/j.arcontrol.2016.09.019>.
- Lu, L., Chen, Z., Yao, B., & Wang, Q. (2013). A two-loop performance-oriented tip-tracking control of a linear-motor-driven flexible beam system with experiments. *IEEE Transactions on Industrial Electronics*, 60(3), 1011–1022. <http://dx.doi.org/10.1109/TIE.2012.2188262>.
- Luca, A. D., & Siciliano, B. (1989). Trajectory control of a non-linear one-link flexible arm. *International Journal of Control*, 50(5), 1699–1715. <http://dx.doi.org/10.1080/00207178908953460>.
- Maciejowski, J. M. (2002). *Predictive control: with constraints* (1st ed.). (p. 331). Prentice Hall.
- Maeder, U., & Morari, M. (2010). Offset-free reference tracking with model predictive control. *Automatica*, 46(9), 1469–1476. <http://dx.doi.org/10.1016/j.automatica.2010.05.023>.
- Makkar, C., Hu, G., Sawyer, W., & Dixon, W. (2007). Lyapunov-based tracking control in the presence of uncertain nonlinear parameterizable friction. *IEEE Transactions on Automatic Control*, 52(10), 1988–1994. <http://dx.doi.org/10.1109/TAC.2007.904254>.
- Meckl, P. H., & Seering, W. P. (1985). Minimizing residual vibration for point-to-point motion. *Journal of Vibration and Acoustics*, 107(4), 378–382. <http://dx.doi.org/10.1115/1.3269276>.
- Mohamed, Z., & Tokhi, M. (2004). Command shaping techniques for vibration control of a flexible robot manipulator. *Mechatronics*, 14(1), 69–90. [http://dx.doi.org/10.1016/S0957-4158\(03\)00013-8](http://dx.doi.org/10.1016/S0957-4158(03)00013-8).
- Morris, A. S., & Madani, A. (1998). Quadratic optimal control of a two-flexible-link robot manipulator. *Robotica*, 16(1), 97–108. <http://dx.doi.org/10.1017/S0263574798000186>.
- Oh, Y., & Chung, W. K. (1999). Disturbance-observer-based motion control of redundant manipulators using inertially decoupled dynamics. *IEEE/ASME Transactions on Mechatronics*, 4(2), 133–146. <http://dx.doi.org/10.1109/3516.769540>.
- Ohishi, K., Ogino, Y., & Hotta, M. (1989). High performance motion control based on model following acceleration joint control method. In *Proceedings, 1989 international conference on robotics and automation* (pp. 1792–1798). IEEE Comput. Soc. Press, <http://dx.doi.org/10.1109/ROBOT.1989.100234>.
- Ohishi, K., Ohnishi, K., & Miyachi, K. (1983). Torque-speed regulation of DC motor based on load torque estimation method. In *IPEC-Tokyo conference record (vol. 2)* (pp. 1209–1218).
- Okwudire, C., & Altintas, Y. (2009). Minimum tracking error control of flexible ball screw drives using a discrete-time sliding mode controller. *Journal of Dynamic Systems, Measurement, and Control*, 131(5), Article 051006. <http://dx.doi.org/10.1115/1.3155005>.
- Poignet, P., Gautier, M., & Khalil, W. (1999). Modeling, control and simulation of high speed machine tool axes. In *1999 IEEE/ASME international conference on advanced intelligent mechatronics* (pp. 617–622). IEEE, <http://dx.doi.org/10.1109/AIM.1999.803239>.

- Pradhan, S. K., & Subudhi, B. (2014). Nonlinear adaptive model predictive controller for a flexible manipulator: an experimental study. *IEEE Transactions on Control Systems Technology*, 22(5), 1754–1768. <http://dx.doi.org/10.1109/TCST.2013.2294545>.
- Qin, S., & Badgwell, T. A. (2003). A survey of industrial model predictive control technology. *Control Engineering Practice*, 11(7), 733–764. [http://dx.doi.org/10.1016/S0967-0661\(02\)00186-7](http://dx.doi.org/10.1016/S0967-0661(02)00186-7).
- Rahimi, H. N., & Nazemizadeh, M. (2014). Dynamic analysis and intelligent control techniques for flexible manipulators: a review. *Advanced Robotics*, 28(2), 63–76. <http://dx.doi.org/10.1080/01691864.2013.839079>.
- Rakovic, S., Kerrigan, E., Mayne, D., & Lygeros, J. (2006). Reachability analysis of discrete-time systems with disturbances. *IEEE Transactions on Automatic Control*, 51(4), 546–561. <http://dx.doi.org/10.1109/TAC.2006.872835>.
- Rungger, M., & Tabuada, P. (2017). Computing robust controlled invariant sets of linear systems. *IEEE Transactions on Automatic Control*, 62(7), 3665–3670. <http://dx.doi.org/10.1109/TAC.2017.2672859>, arXiv:1601.00416.
- Sekara, T. B., & Matausek, M. R. (2009). Optimization of PID controller based on maximization of the proportional gain under constraints on robustness and sensitivity to measurement noise. *IEEE Transactions on Automatic Control*, 54(1), 184–189. <http://dx.doi.org/10.1109/TAC.2008.2008359>.
- Serkies, P. J., & Szabat, K. (2013). Application of the MPC to the position control of the two-mass drive system. *IEEE Transactions on Industrial Electronics*, 60(9), 3679–3688. <http://dx.doi.org/10.1109/TIE.2012.2208435>.
- Singer, N. C., & Seering, W. P. (1990). Preshaping command inputs to reduce system vibration. *Journal of Dynamic Systems, Measurement, and Control*, 112(1), 76–82. <http://dx.doi.org/10.1115/1.2894142>.
- Singer, N., Singhose, W., & Seering, W. (1999). Comparison of filtering methods for reducing residual vibration. 5(2–4), 208–218. [http://dx.doi.org/10.1016/S0947-3580\(99\)70155-X](http://dx.doi.org/10.1016/S0947-3580(99)70155-X).
- Singhose, W. (2009). Command shaping for flexible systems: a review of the first 50 years. *International Journal of Precision Engineering and Manufacturing*, 10(4), 153–168. <http://dx.doi.org/10.1007/s12541-009-0084-2>.
- Singhose, W., & Vaughan, J. (2011). Reducing vibration by digital filtering and input shaping. *IEEE Transactions on Control Systems Technology*, 19(6), 1410–1420. <http://dx.doi.org/10.1109/TCST.2010.2093135>.
- Sira-Ramirez, H., Linares-Flores, J., Garcia-Rodriguez, C., & Contreras-Ordaz, M. A. (2014). On the control of the permanent magnet synchronous motor: an active disturbance rejection control approach. *IEEE Transactions on Control Systems Technology*, 22(5), 2056–2063. <http://dx.doi.org/10.1109/TCST.2014.2298238>.
- Slotine, J. J., & Sastry, S. S. (1983). Tracking control of non-linear systems using sliding surfaces, with application to robot manipulators. *International Journal of Control*, 38(2), 465–492. <http://dx.doi.org/10.1080/00207178308933088>.
- Solsona, J., Valla, M., & Muravchik, C. (2000). Nonlinear control of a permanent magnet synchronous motor with disturbance torque estimation. *IEEE Transactions on Energy Conversion*, 15(2), 163–168. <http://dx.doi.org/10.1109/60.866994>.
- Statista (2018). Global motion control market size between 2016 and 2022.
- Steinbuch, M., & Norg, M. (1998). Advanced motion control: an industrial perspective. *European Journal of Control*, 4(4), 278–293. [http://dx.doi.org/10.1016/S0947-3580\(98\)70121-9](http://dx.doi.org/10.1016/S0947-3580(98)70121-9).
- Stephens, M., Manzie, C., & Good, M. (2010). On the stability analysis and modelling of a multirate control direct-drive machine tool axis subject to large changes in load dynamics. In *Proceedings of the 2010 American control conference* (pp. 1550–1555). IEEE, <http://dx.doi.org/10.1109/ACC.2010.5531542>.
- Stephens, M. A., Manzie, C., & Good, M. C. (2013). Model predictive control for reference tracking on an industrial machine tool servo drive. *IEEE Transactions on Industrial Informatics*, 9(2), 808–816. <http://dx.doi.org/10.1109/TII.2012.2223222>.
- Su, Y., Duan, B., Zheng, C., Zhang, Y., Chen, G., & Mi, J. (2004). Disturbance-rejection high-precision motion control of a Stewart platform. *IEEE Transactions on Control Systems Technology*, 12(3), 364–374. <http://dx.doi.org/10.1109/TCST.2004.824315>.
- Su, Y., Zheng, C., & Duan, B. (2005). Automatic disturbances rejection controller for precise motion control of permanent-magnet synchronous motors. *IEEE Transactions on Industrial Electronics*, 52(3), 814–823. <http://dx.doi.org/10.1109/TIE.2005.847583>.
- Su, Y., Zheng, C., Sun, D., & Duan, B. (2005). A simple nonlinear velocity estimator for high-performance motion control. *IEEE Transactions on Industrial Electronics*, 52(4), 1161–1169. <http://dx.doi.org/10.1109/TIE.2005.851598>.
- Suh, S.-M., Chung, C. C., & Lee, S.-H. (2001). Discrete-time LQG/LTR dual-stage controller design in magnetic disk drives. *IEEE Transactions on Magnetics*, 37(4), 1891–1895. <http://dx.doi.org/10.1109/20.951000>.
- Sun, B., & Gao, Z. (2005). A DSP-based active disturbance rejection control design for a 1-kW H-bridge DC–DC power converter. *IEEE Transactions on Industrial Electronics*, 52(5), 1271–1277. <http://dx.doi.org/10.1109/TIE.2005.855679>.
- Szabat, K., & Orłowska-Kowalska, T. (2007). Vibration suppression in a two-mass drive system using PI speed controller and additional feedbacks - comparative study. *IEEE Transactions on Industrial Electronics*, 54(2), 1193–1206. <http://dx.doi.org/10.1109/TIE.2007.892608>.
- Talole, S., Kolhe, J., & Phadke, S. (2010). Extended-state-observer-based control of flexible-joint system with experimental validation. *IEEE Transactions on Industrial Electronics*, 57(4), 1411–1419. <http://dx.doi.org/10.1109/TIE.2009.2029528>.
- Tan, K. K., Lee, T. H., Dou, H. F., Chin, S. J., & Zhao, S. (2003). Precision motion control with disturbance observer for pulsedwidth-modulated-driven permanent-magnet linear motors. *IEEE Transactions on Magnetics*, 39(3), 1813–1818. <http://dx.doi.org/10.1109/TMAG.2003.810617>.
- Tan, K., Lim, S., Huang, S., Dou, H., & Giam, T. (2004). Coordinated motion control of moving gantry stages for precision applications based on an observer-augmented composite controller. *IEEE Transactions on Control Systems Technology*, 12(6), 984–991. <http://dx.doi.org/10.1109/TCST.2004.833608>.
- Tan, W., Liu, J., Chen, T., & Marquez, H. J. (2006). Comparison of some well-known PID tuning formulas. *Computers and Chemical Engineering*, 30(9), 1416–1423. <http://dx.doi.org/10.1016/j.compchemeng.2006.04.001>.
- Thomsen, S., Hoffmann, N., & Fuchs, F. W. (2011). PI control, PI-based state space control, and model-based predictive control for drive systems with elastically coupled loads - a comparative study. *IEEE Transactions on Industrial Electronics*, 58(8), 3647–3657. <http://dx.doi.org/10.1109/TIE.2010.2089950>.
- Tso, S. K., Yang, T. W., Xu, W. L., & Sun, Z. Q. (2003). Vibration control for a flexible-link robot arm with deflection feedback. *International Journal of Non-Linear Mechanics*, 38, 51–62. [http://dx.doi.org/10.1016/S0020-7462\(01\)00040-3](http://dx.doi.org/10.1016/S0020-7462(01)00040-3).
- Umeno, T., & Hori, Y. (1991). Robust speed control of DC servomotors using modern two degrees-of-freedom controller design. *IEEE Transactions on Industrial Electronics*, 38(5), 363–368. <http://dx.doi.org/10.1109/41.97556>.
- Van Brussel, H., & Van den Braembusche, P. (1998). Robust control of feed drives with linear motors. *CIRP Annals*, 47(1), 325–328. [http://dx.doi.org/10.1016/S0007-8506\(07\)62843-1](http://dx.doi.org/10.1016/S0007-8506(07)62843-1).
- Visioli, A., & Legnani, G. (2002). On the trajectory tracking control of industrial SCARA robot manipulators. *IEEE Transactions on Industrial Electronics*, 49(1), 224–232. <http://dx.doi.org/10.1109/41.982266>.
- Vukosavic, S., & Stojic, M. (1998). Suppression of torsional oscillations in a high-performance speed servo drive. *IEEE Transactions on Industrial Electronics*, 45(1), 108–117. <http://dx.doi.org/10.1109/41.661311>.
- Wang, X., & Chen, D. (2006). Output tracking control of a one-link flexible manipulator via causal inversion. *IEEE Transactions on Control Systems Technology*, 14(1), 141–148. <http://dx.doi.org/10.1109/TCST.2005.859628>.
- Yang, X., & Huang, Y. (2009). Capabilities of extended state observer for estimating uncertainties. In *2009 American control conference* (pp. 3700–3705). IEEE, <http://dx.doi.org/10.1109/ACC.2009.5160642>.
- Yang, J.-M., & Kim, J.-H. (1999). Sliding mode control for trajectory tracking of nonholonomic wheeled mobile robots. *IEEE Transactions on Robotics and Automation*, 15(3), 578–587. <http://dx.doi.org/10.1109/70.768190>.
- Yang, J., Wang, J., Wu, B., Li, S., & Li, Q. (2015). Extended state observer-based sliding mode control for PWM-based DC–DC buck power converter systems with mismatched disturbances. *IET Control Theory & Applications*, 9(4), 579–586. <http://dx.doi.org/10.1049/iet-cta.2014.0220>.
- Yao, B., Al-Majed, M., & Tomizuka, M. (1997). High-performance robust motion control of machine tools: an adaptive robust control approach and comparative experiments. *IEEE/ASME Transactions on Mechatronics*, 2(2), 63–76. <http://dx.doi.org/10.1109/3516.588624>.
- Yao, J., Jiao, Z., & Ma, D. (2014). Adaptive robust control of DC motors with extended state observer. *IEEE Transactions on Industrial Electronics*, 61(7), 3630–3637. <http://dx.doi.org/10.1109/TIE.2013.2281165>.
- Yuan, M., Manzie, C., Good, M., Shames, I., Gan, L., Keynejad, F., & Robinette, T. (2019). Error-bounded reference tracking MPC for machines with structural flexibility. *IEEE Transactions on Industrial Electronics*, 67(10), 8143–8154. <http://dx.doi.org/10.1109/TIE.2019.2949521>.
- Yuan, M., Manzie, C., Good, M., Shames, I., Keynejad, F., & Robinette, T. (2019). Bounded error tracking control for contouring systems with end effector measurements. In *2019 IEEE international conference on industrial technology* (pp. 66–71). IEEE, <http://dx.doi.org/10.1109/ICIT.2019.8755064>.
- Yun, J. N., Su, J., Kim, Y. I., & Kim, Y. C. (2013). Robust disturbance observer for two-inertia system. *IEEE Transactions on Industrial Electronics*, 60(7), 2700–2710. <http://dx.doi.org/10.1109/TIE.2012.2194976>.
- Zhang, C., & Chen, Y. (2016). Tracking control of ball screw drives using ADRC and equivalent-error-model-based feedforward control. *IEEE Transactions on Industrial Electronics*, 63(12), 7682–7692. <http://dx.doi.org/10.1109/TIE.2016.2590992>.
- Zheng, Q., Gaol, L. Q., & Gao, Z. (2007). On stability analysis of active disturbance rejection control for nonlinear time-varying plants with unknown dynamics. In *2007 46th IEEE conference on decision and control* (pp. 3501–3506). IEEE, <http://dx.doi.org/10.1109/CDC.2007.4434676>.
- Zhou, P., Dai, W., & Chai, T. Y. (2014). Multivariable disturbance observer based advanced feedback control design and its application to a grinding circuit. *IEEE Transactions on Control Systems Technology*, 22(4), 1474–1485. <http://dx.doi.org/10.1109/TCST.2013.2283239>.
- Zhu, G., Ge, S. S., & Lee, T. H. (1999). Simulation studies of tip tracking control of a single-link flexible robot based on a lumped model. *Robotica*, 17(1), 71–78. <http://dx.doi.org/10.1017/S0263574799000971>.