



CHALMERS
UNIVERSITY OF TECHNOLOGY

Method development and evaluation of product gas mixture from a semi-industrial scale fluidized bed steam cracker with GC-VUV

Downloaded from: <https://research.chalmers.se>, 2026-04-04 11:12 UTC

Citation for the original published paper (version of record):

Mandviwala, C., Forero Franco, R., Gogolev, I. et al (2024). Method development and evaluation of product gas mixture from a semi-industrial scale fluidized bed steam cracker with GC-VUV. *Fuel Processing Technology*, 253. <http://dx.doi.org/10.1016/j.fuproc.2023.108030>

N.B. When citing this work, cite the original published paper.

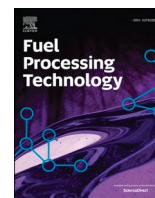

Method development and evaluation of product gas mixture from a semi-industrial scale fluidized bed steam cracker with GC-VUV

Chahat Mandviwala^{*}, Renesteban Forero Franco^{*}, Ivan Gogolev, Judith González-Arias, Teresa Berdugo Vilches, Isabel Cañete Cañete Vela, Henrik Thunman, Martin Seemann

Department of Space, Earth and Environment (SEE), Division of Energy Technology, Chalmers University of Technology, 412 96 Gothenburg, Sweden

ARTICLE INFO

Keywords:

GC-VUV
Hydrocarbons
Steam cracking
Dual fluidized bed
Polyethylene
Plastic recycling

ABSTRACT

Steam cracking in fluidized beds offers an alternative to conventional steam cracking for sustainable hydrocarbon production. This approach has gained interest, particularly in the context of recycling plastics to generate valuable hydrocarbons. Integrating this process into existing petrochemical clusters necessitates a thorough characterization of the products derived from this new feedstock. This work focuses on addressing the challenges associated with species quantification and characterization time for assessing the product mixture resulting from a steam cracking process. The experiments were conducted in a semi-industrial scale dual fluidized bed steam cracker, utilizing polyethylene as the feedstock. To sample species spanning from C1 to C18, cooling, scrubbing, and adsorption were introduced. These steps were integrated with GC-VUV (Gas Chromatography with Vacuum Ultraviolet Spectroscopy) and other widely recognized analytical methods to quantify the sampled species. The primary focus was on GC-VUV analysis as a suitable characterization method for identifying and quantifying C4 to C18 species, which can constitute up to 35% of the product mixture obtained from polyethylene steam cracking (750 °C to 850 °C). Quantifying C6 to C18 hydrocarbons becomes the time-critical step, with GC-VUV potentially achieving this in 1/6th of the analysis time and with relatively optimal quantification compared to the traditional characterization methods.

1. Introduction

Steam cracking is a thermochemical process for conversion of hydrocarbons, commonly obtained from fossil resources, into molecules such as ethylene and propylene. Molecules acquired through this process form the foundation for a diverse range of products, including plastics, textiles, pharmaceuticals, and electronics. Consequently, the role of steam cracking emerges as pivotal in facilitating the production of fundamental materials intricately woven into the fabric of the modern world [1–3].

Utilizing fossil resources as the feedstock for the steam cracking process poses a significant sustainability challenge. In the context of phasing out such resources, an alternative strategy involves utilizing renewable and/or waste streams as feedstock [4–7]. Within this context, employing fluidized beds for steam cracking of waste streams has gained traction as a promising substitute to conventional coil reactor-based steam cracking process. Notably there has been a growing interest in the utilization of fluidized bed steam cracking in recent years,

particularly for recycling of waste plastic streams and renewable resources such as waste cooking oil [5,8–11].

In this process, plastic waste undergoes thermochemical conversion by being exposed to a heated bed material. This method aims to break down the long-chain hydrocarbons present in the polymer structure of plastics into smaller hydrocarbons within a steam environment [8,10]. The resulting products cover a broad range of hydrocarbons (C1 to C30), with a specific distribution depending on the polymer composition within the plastic waste and the reaction conditions [9]. The product distribution mainly consists of light olefins (C2–C3) when polyolefins undergo steam cracking at temperatures between 700 °C and 800 °C [10,12,13]. In the case of polyethylene terephthalate (PET) and polystyrene (PS) subjected to steam cracking, the product distribution is enriched with benzene, toluene, xylenes, and styrene (BTXS) [9,14]. The steam-rich environment within the fluidized bed steam cracker also facilitates the generation of syngas through steam reforming and the water-gas shift reaction [10,15,16]. Furthermore, the steam cracking of plastics is known to produce methane, polycyclic aromatic

^{*} Corresponding authors.

E-mail addresses: chahat@chalmers.se (C. Mandviwala), rforero@chalmers.se (R. Forero Franco).

<https://doi.org/10.1016/j.fuproc.2023.108030>

Received 2 October 2023; Received in revised form 19 December 2023; Accepted 27 December 2023

Available online 5 January 2024

0378-3820/© 2024 The Authors. Published by Elsevier B.V. This is an open access article under the CC BY license (<http://creativecommons.org/licenses/by/4.0/>).

hydrocarbons (PAHs), and coke within the reactor [10,16,17]. Fig. 1, in general, illustrates the various carbon-containing compounds that constitute the product mixture generated through the steam cracking of plastic materials.

The product mixture derived from a steam cracker is subjected to a series of separation processes, including distillation and fractionation, aiming to isolate various components based on their boiling points. These separation operations are essential in order to obtain valuable products. The separated fractions may necessitate additional chemical transformations, such as hydrogenation and isomerization, to obtain valuable end products [1,2]. Consequently, when designing the downstream operations, it becomes crucial to determine the composition of the product stream, encompassing all the species present within the mixture. Therefore, the characterization of the products obtained from the steam cracker revolves around the identification and quantification of all the constituents within the product mixture.

The existing methodologies for characterizing the product mixture obtained from thermochemical conversion of plastic waste are deemed suitable for assessing the process performance [10,13,18,19]. However, these methods are either insufficient or intricate when it comes to determining the complete composition of the product mixture obtained specifically through steam cracking. The challenges are mainly centered on the identification of a vast range of product species and the time required for analysis. In the event of integrating steam cracking of plastics with the current petrochemical clusters [8], it becomes necessary to develop new and time efficient methodologies that can comprehensively characterize the composition of the products derived from this new feedstock.

Pyl et al. have previously addressed challenges associated with the comprehensive characterization of steam cracking product mixtures. They introduced an innovative approach involving a two-dimensional gas chromatography (GCxGC) method for the online analysis of steam cracker effluents. This GCxGC system was coupled with a flame ionization detector (FID) and a time-of-flight mass spectrometer (TOF-MS), allowing for both quantitative and qualitative analysis of steam cracking product mixtures. The enhanced separation power of GCxGC facilitated the effective separation of species in the C1 to C25 range [20]. Since its introduction, this approach has been widely adopted by researchers for characterizing steam cracking and pyrolysis product mixtures obtained from various feedstocks [21–24].

An alternative to GCxGC, a recent advancement in gas

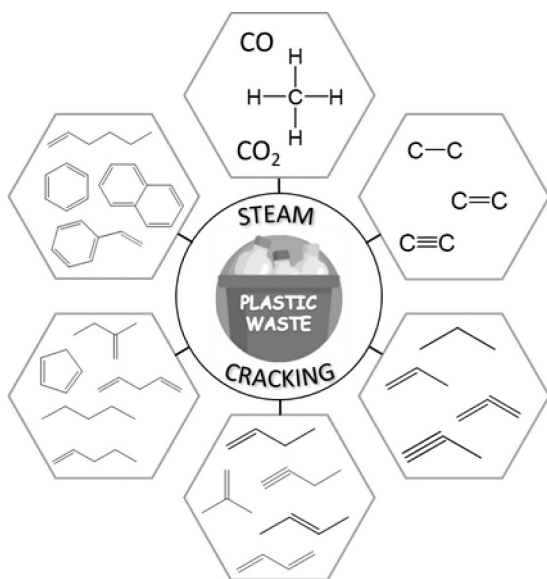

Fig. 1. Carbon-containing species present in the product mixture obtained from steam cracking of plastic materials.

chromatography has introduced a novel vacuum ultraviolet (VUV) detector designed specifically for analyzing a broad spectrum of hydrocarbons [25,26]. When coupled with a GC, the VUV detector inherently adds a second dimension to chromatographic data in the form of an absorption spectrum. This feature allows for both quantitative and qualitative analysis of coeluting species within the GC column [26]. The unique capabilities of the VUV detector hold the promise of significantly reducing the analysis time for complex product mixtures. As a result, a few researchers have adopted the GC-VUV method for characterizing complex pyrolysis oil mixtures [25,27]. Despite this widespread application, it is noteworthy that, to the best of the authors' knowledge, there is currently no study demonstrating the potential of the GC-VUV method for characterizing steam cracker effluents.

In this study, we present a series of GC-VUV results derived from tests conducted within a semi-industrial scale dual fluidized bed (DFB) steam cracker. Additionally, we provide the validation of the carbon balance obtained using GC-VUV analysis against alternative sampling and analytical techniques. To obtain a broad spectrum of hydrocarbons in the product mixture, virgin polyethylene pellets were subjected to steam cracking under diverse process conditions. The study also aims to present a validated sampling and analysis methodology to provide a comprehensive carbon balance of the products out of a steam cracking process. Furthermore, we demonstrate the capability of GC-VUV to characterize the extensive range of species present in the cracker effluent within a concise analytical timeframe.

2. Theoretical background

Sampling and analysis systems for product gas mixtures derived from thermochemical reactors such as steam crackers, pyrolyzers, or gasifiers come in various sizes and designs, tailored to specific applications. However, despite the diversity in design, certain generalizations can be made regarding the process layout [28]. In Fig. 2, we illustrate the typical sequence of steps involved in the sampling and analysis of products originating from a thermochemical reactor.

In this process, the product gas mixture is generated in the thermochemical reactor and is transported through heated pipes and a particle filter, before reaching the hot sampling point. The particle filter eliminates the suspended solid particles in the gas mixture that may originate from the reactor. The steps in this chain are described below, with an emphasis on highlighting the challenges faced in each step, specifically in the context of analyzing the product mixture from a steam cracker.

2.1. Sampling of hot gases

In the analysis of hot product gases, it is a common practice to direct a sample of the entire mixture derived from the reactor into the analytical equipment. To prevent the condensation of any species, present in the gas mixture, the sample is usually maintained within the temperature range of 250 to 350 °C [29,30]. Various GC techniques such as GC-MS, GC-FID, GC-TCD, or GCxGC are typically employed to analyze the products [28–30].

Elordi et al. utilized a similar approach by employing a GC-FID system to analyze the hot volatiles produced from the pyrolysis of polyethylene. To achieve effective separation of C1–C4 hydrocarbons, a temperature program was employed as follows: an initial period of 4.5 min at 35 °C. Subsequently, a ramp with a rate of 15 °C per minute was applied, increasing the temperature to 305 °C. Finally, a hold time of 5.5 min at 305 °C was implemented to ensure the complete elution of all hydrocarbons from the GC column [29]. This methodology was also employed by Artexe et al. in their study, where they aimed to characterize the volatiles generated through a two-step pyrolysis process of polyethylene [31].

This approach proves to be valuable for studying the composition of the mixture obtained from a pyrolysis process. However, when this method is applied to a steam cracker, it presents certain challenges that

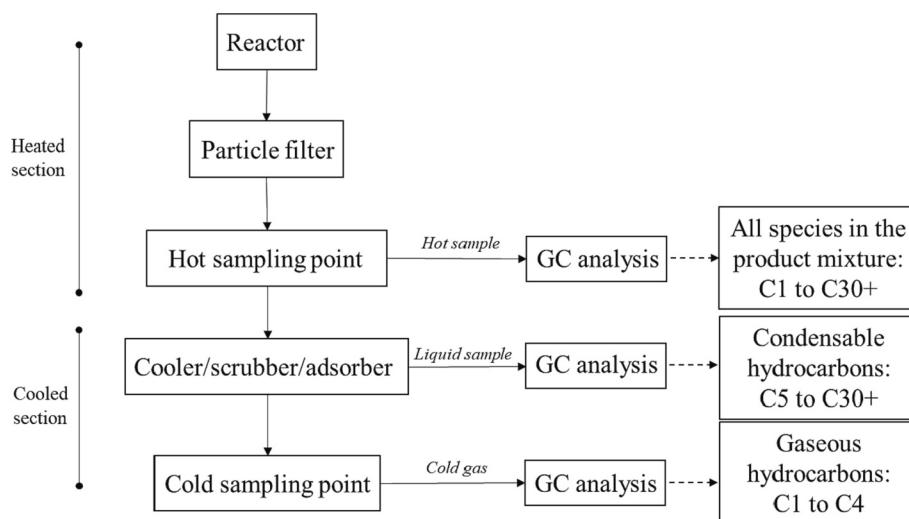

Fig. 2. Three general steps involved in the sampling of product mixture obtained from a thermochemical process, followed by characterization of each of the samples through GC analysis. The solid arrow lines represent the flow of product mixture/sample and the dashed arrow lines represent the analytical results obtained from GC analysis.

need to be addressed. One major challenge arises from the presence of steam in the steam cracking product mixture. The steam content adversely affects the performance of the GC column, leading to poor resolution and quantification of the light hydrocarbon species. Furthermore, the GC analysis method described requires extended run times of 45 to 90 min to prevent coelution of different species. This extended duration limits the number of samples that can be analyzed during a given stable operation. Consequently, the efficiency and throughput of the analysis are reduced.

2.2. Sampling by cooling, scrubbing or adsorption

The sampling of condensable species in the product mixture is commonly accomplished through three distinct procedures: cooling, scrubbing, or adsorption [28,30,32,33]. The cooling method entails reducing the temperature of the product gas, typically to around $-20\text{ }^{\circ}\text{C}$, causing the condensation of the liquid fraction. The analysis of the condensate is commonly performed using either GC-FID or GC-MS techniques. Alternatively, the scrubbing procedure involves bringing the hot product gas into contact with a cold solvent, which facilitates the separation of the condensable species. The resulting scrubbing liquid can then be subjected to analysis using similar methods as those employed for the condensate obtained from the cooling method. Lastly, the adsorption technique involves passing the product gas through an adsorption column, where specific species are selectively adsorbed [28,33]. Subsequently, the adsorbed species are recovered through desorption or elution for further GC-MS or GC-FID analysis.

In a study conducted by Jung et al., the sampling of condensable fractions resulting from the pyrolysis of polyolefins was achieved using a cooling system maintained at $-30\text{ }^{\circ}\text{C}$ [13]. Subsequently, the obtained condensable fraction was subjected to distillation to separate it into a light and a heavy fraction. To further analyze the composition of the light distilled oil, both quantitative and qualitative analyses were performed using GC-MS and GC-FID techniques. To ensure a complete carbon balance, the residues obtained from the distillation process were ignited in a muffle furnace at a temperature of $850\text{ }^{\circ}\text{C}$. Similarly, Achilias et al. performed separation of liquid fraction obtained from pyrolysis of waste polyolefins using a cold liquid bath maintained at $-17\text{ }^{\circ}\text{C}$ [34]. The collected liquid samples were characterized by GC-MS analysis.

Wilk and Hofbauer conducted a study on the gasification of mixed plastic waste, where they employed an impinger bottle system for

scrubbing the product gases [10]. In this system, toluene was utilized as the solvent. The objective was to remove water, dust, char, and tars from the gases, which were subsequently analyzed through gravimetric and GC-MS methods. This impinger bottle scrubbing system employed by Wilk and Hofbauer followed a conventional tar protocol, which normally employs isopropanol to effectively remove tars found in gasification producer gases [10,32].

Israelsson et al. conducted an evaluation of gasification tars sampling, focusing on a widely used adsorption method known as Solid Phase Adsorption (SPA) [28]. The study revealed that the SPA method demonstrated accuracy and repeatability, making it suitable for applications in large-scale gasifiers. As a result, several researchers have since utilized the SPA method to quantify the aromatic hydrocarbons generated from the thermochemical conversion of polyolefins [5,16,35].

Sampling through cooling, scrubbing, or adsorption methods is valuable for analyzing the composition of the condensable fraction obtained from thermochemical processes. However, when applying these methods to a steam cracker, certain challenges arise that require attention. One challenge involves accurately quantifying volatile species like C4-C5 hydrocarbons and monoaromatics, as these can evaporate after sample collection. Additionally, the use of a solvent in the scrubbing method may dilute the condensable species, leading to inaccurate quantification of trace species. Furthermore, the presence of steam in the product mixture can impact the performance of the solvent or the adsorption column, adding to the complexity of the analysis process [28].

2.3. Sampling of cold gases

Sampling and analyzing cold gases are generally simpler techniques compared to the methods discussed earlier. This approach typically involves sampling the gases after they have undergone cooling, scrubbing, or adsorption. By following these steps, a cold-dry gas is obtained, devoid of condensable species. The next step involves analyzing the volumetric composition of this cold-dry gas using a gas analyzer or a GC. The most commonly used analytical equipment for this purpose is a GC equipped with a TCD detector [13,16,31]. This method can be performed either online or offline, utilizing gas bags, and it enables quick quantification of H_2 , CO , CO_2 , and C1 – C3 hydrocarbons present in the product mixture.

A method introduced by Pyl et al. involved passing steam cracker effluents through a water-cooled heat exchanger and a dehydrator. This

sequential process aimed to eliminate condensable hydrocarbons and water from the effluent mixture. Subsequently, the refined effluent mixture underwent analysis using a refinery gas analyzer (RGA). This analytical approach facilitated the quantification of C1 to C4 species within the cooled effluent [20].

In the sampling and analysis of cold gases, the quantification of C4 – C5 hydrocarbons remains a challenging task. This difficulty arises because these compounds are prone to removal during the cooling and drying stages. Compounding this challenge is the presence of substantial amount of steam in the cracker effluent, further complicating the cooling and drying procedures.

In summary, the steps outlined in Fig. 2 will collectively contribute to the overall error in characterization of the steam cracker product mixture. These errors primarily arise from the sampling methods employed at each stage. Moreover, to overcome the challenges posed by the substantial number of species present in the product gas, GC analysis emerges as the time determining step. To address these concerns, our study presents a method that integrates the three general sampling steps illustrated in Fig. 2 with GC-VUV analysis, ensuring the representation of species ranging from C1 to C18 hydrocarbons in the steam cracker product gas. Additionally, we demonstrate the effectiveness of the VUV detector in deconvoluting up to four coeluting species from the GC column, which significantly reduces analysis time compared to GC-FID or GC-TCD analysis.

3. Materials and method

3.1. Experimental setup

The experiments described in this work were carried out in a dual fluidized bed (DFB) steam cracker at Chalmers University of Technology. The steam cracker reactor is a bubbling fluidized bed, which is coupled to a 12-MW_{th} circulating fluidized bed (CFB) boiler. The steam cracker has a feedstock processing capacity of up to 300 kg/h. A simplified sketch of the system is depicted in Fig. 3 (adapted from the work performed by Cañete Vela et al) [36]. A detailed description of the DFB reactor system can be found in the work conducted by Larsson et al.

[30].

In this setup, a bed material continuously circulates between the boiler and the steam cracker, facilitated by a cyclone and an intermediate fluidized bed vessel, also known as the particle distributor. The bed material enters the steam cracker through a loop seal, and subsequently returns to the boiler via a second loop seal. Both the loop seals and the steam cracker are fluidized with steam which prevents the exchange of gases between the boiler and the steam cracker. The steam cracker and the loop seals received a steam supply of 150 kg/h and 35 kg/h, respectively, the minimum necessary to avoid defluidization. The bed material used in the process was silica-sand. The density, mean particle size, and the chemical properties of the bed material are detailed in supplementary information Table S1.

The polyethylene pellets, which served as the feedstock for the steam cracker, were supplied by Borealis AB located in Stenungsund, Sweden. The polyethylene pellets had a bulk density of 945 kg/m³ and an average pellet size of 2.5 mm. The polyethylene pellets were primarily comprised of carbon (84 wt%) and hydrogen (15 wt%). To provide comprehensive information about the polyethylene pellets, Table S2 (supplementary information) summarizes both the proximate analysis and the chemical composition of the material.

In this experimental setup, the introduction of polyethylene into the steam cracker occurs near loop seal 1, as illustrated in Fig. 3. To facilitate this process, an extruder is employed, allowing a molten polyethylene stream to be added from the top. The extruder serves two important purposes: (1) it ensures the isolation of the steam cracker from the atmospheric air, thereby maintaining a controlled environment within the system; and (2) the extruder enables precise control of the feeding rate of the polyethylene pellets, allowing for accurate and consistent feedstock delivery.

In the steam cracker setup, the resulting gas mixture is directed to the boiler through the product gas line, as depicted in Fig. 3. Since this facility primarily serves as a research site, the product gas undergoes combustion on the boiler side. However, in a commercial unit, the product gas would undergo gas cleaning processes before being directed toward its final application. Additionally, the boiler employs the combustion of wood chips or wood pellets to generate heat and electricity for

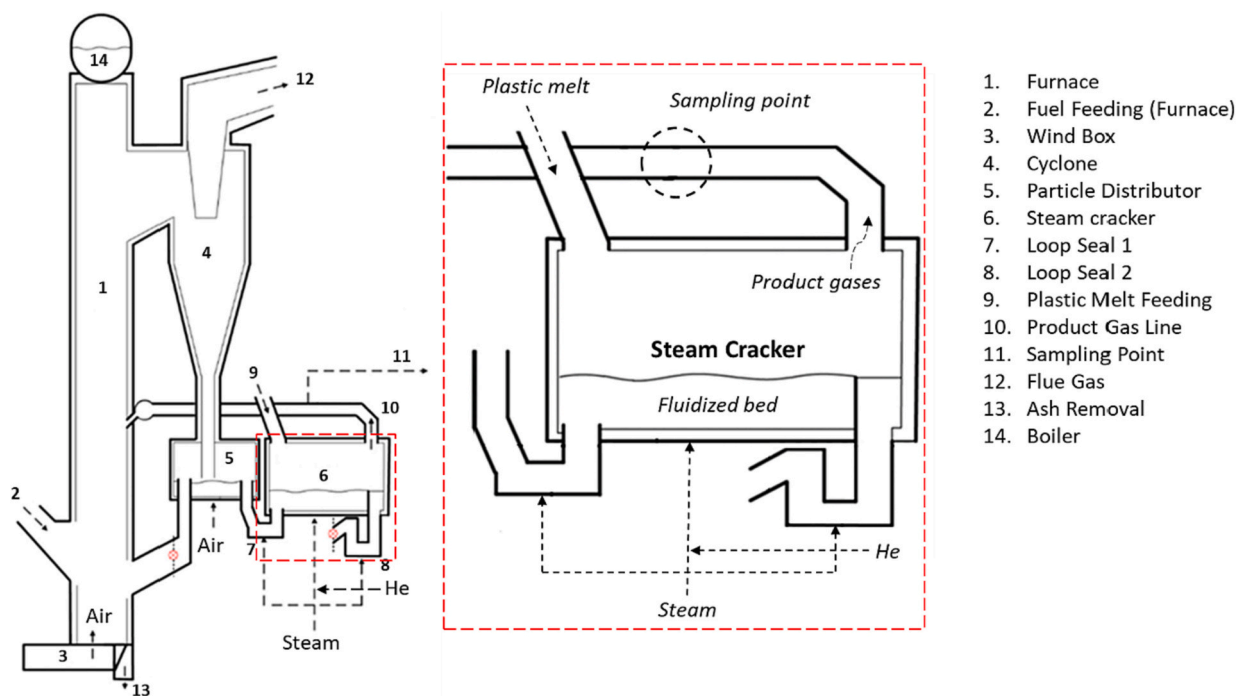

Fig. 3. Schematic of the dual fluidized bed (DFB) steam cracker at Chalmers University of Technology. The DFB system consists of a circulating fluidized bed boiler (1) and a bubbling fluidized bed steam cracker (6). Adapted from [36].

the Chalmers campus. Furthermore, the solid carbon deposits, commonly referred to as coke, formed on the surface of the bed material within the steam cracker, are also combusted in the boiler. This process facilitates the reintroduction of coke-free bed material back into the steam cracker.

3.2. Sampling and analysis methods

A small flow of helium, at a rate of 35 l/min, is employed as a tracer gas to measure the total dry gas flow per unit of feedstock. The helium is introduced into the fluidization steam, as depicted in Fig. 3. From the product gas line, two parallel slipstreams of the gas mixture, approximately 10 l/min each, are continuously extracted for sampling (see 11 in Fig. 3). The sampling and measurement procedures carried out in the two slipstreams are illustrated in Fig. 4.

The measurement techniques applied to each slipstream are summarized in Table 1, together with the parameters that were quantified by means of each measurement.

Slipstream 1 was utilized for sampling and analyzing individual species within the product gas mixture. To achieve this, four different techniques were employed: (1) SPA, (2) hot gas sampling, (3) gas bag sampling, and (4) permanent gas analysis. The collected samples were subsequently analyzed using GC-FID, GC-VUV, or GC-TCD. The combination of these four sampling techniques allowed for the detection and quantification of species ranging from C1 to C18. Supplementary Information Table S3 contains a comprehensive description of the individual species C1 to C18, along with the analytical equipment employed for their measurement.

The SPA samples were acquired and analyzed following the method described by Israelsson et al. [28]. This method involves quantification of certain aromatic species in the boiling point range of C6 to C18 using GC-FID measurements (see Table S3, supplementary information). For

GC-FID measurement, a series of two double-layered SPA columns were used, as illustrated in Fig. 4. These double-layered columns contained carbon layers that ensured proper sampling of monoaromatics (BTXS) [28]. A single-layered SPA column, which lacked the carbon layers, was employed for GC-VUV measurements. This absence of carbon layers meant that the monoaromatics were not adsorbed onto the column but instead collected downstream of the column, as depicted in Fig. 4.

The SPA (GC-FID) method, pioneered by Israelsson et al., is widely recognized for determining aromatic hydrocarbons in product mixtures derived from thermochemical processes [28]. Numerous researchers have employed this method to quantify aromatic yields in diverse processes like gasification, pyrolysis, and steam cracking of various feedstocks [11,16,33,36,37]. Conducting redundant analysis of SPA samples using GC-VUV serves as a validation step for results obtained through GC-VUV analysis. The quantitative analysis of the SPA samples was conducted on both GC-FID and GC-VUV, utilizing a known quantity of an internal standard (n-Hexylbenzene) added to the samples before GC injection [22].

Downstream of the single layered SPA column, there is a sequential arrangement consisting of a heated cylinder, a pump, and a 0.5 L Tedlar gas bag (refer to Fig. 4). During the sampling process, the pump draws the product gas through the single layered SPA and the heated cylinder, eventually filling up the gas bag. Adsorption being an exothermic process, the temperature of the single-layered SPA column rises to 60 °C during the sampling process. To sustain the gas sample's temperature at 60 °C, an external electrical heating system is employed to warm the gas sampling cylinder. The sample collected in gas bag is kept at room temperature (25 °C). To determine the mass composition of the collected gas samples, GC-VUV analysis is performed. To prevent the loss of volatile organic compounds (VOCs), the gas bag and the hot gas samples were analyzed using GC-VUV within one hour of being collected. Detailed information about the analytical methods employed on the GC-

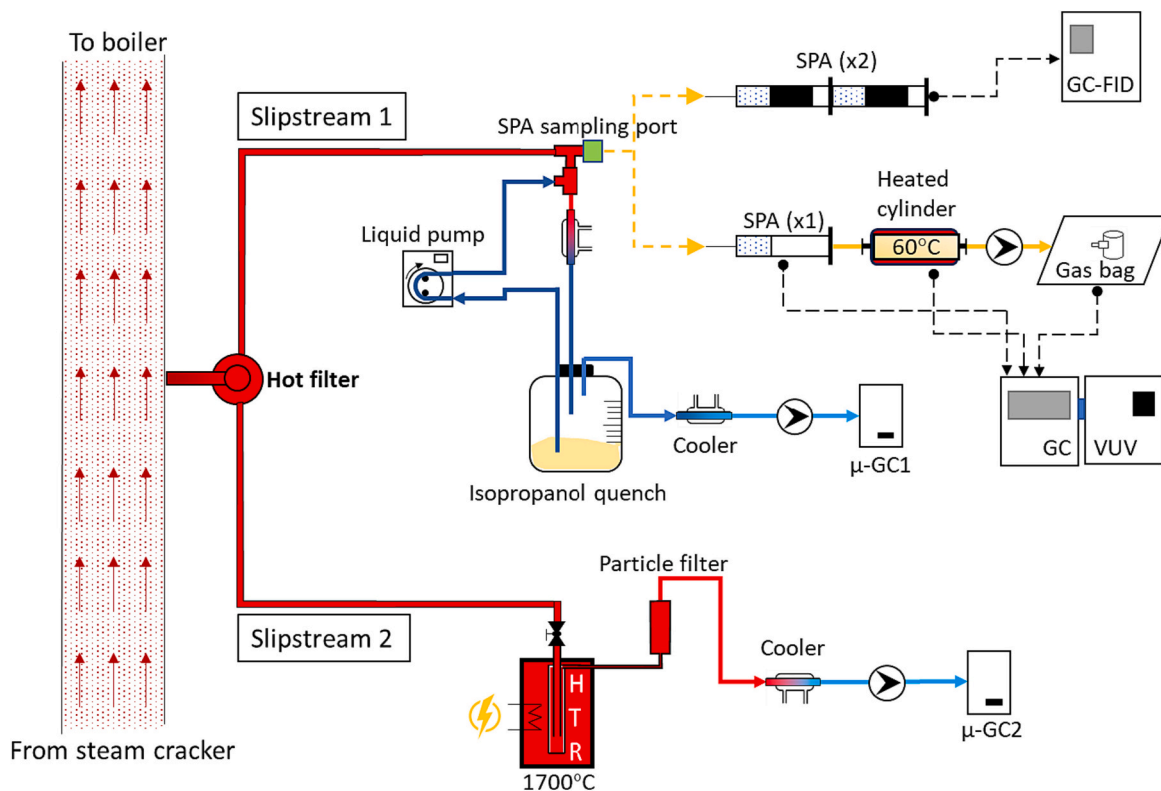

Fig. 4. Simplified schematic of the gas sampling system, including the two parallel slipstreams, and the SPA-sampling position. The hot filter is positioned at ‘point 11’ (see Fig. 2). Red colored lines are the heat-traced lines at 350 °C. The remainder of the piping correspond to the unheated side of the slipstreams. The dotted line represents offline characterization of the individual samples, while the continuous line represents online GC measurements. (For interpretation of the references to colour in this figure legend, the reader is referred to the web version of this article.)

Table 1
Sampling and measurement techniques applied to each slipstream.

	Sampling method	Technical description
Slipstream 1	SPA	SPA tubes: with a single layer of amino propyl-bonded silica or a double adsorbent layer comprising of amino propyl-bonded silica and carbon layers. Analytical instrument: GC-FID (Type BRUKER GC-430) and GC-VUV (Type Thermo Scientific TRACE 1310). Species analyzed: C6 to C18 hydrocarbons.
	Hot gas sample	Heated cylinder: A sampling cylinder for hot gas is connected downstream of the single-layered SPA tube, maintained at a temperature of 60 °C. Analytical instrument: GC-VUV. Species analyzed: C6 to C8 hydrocarbons.
	Gas bag sample	Gas bags: 0.5-L Tedlar® connected downstream of the heated cylinder or the single layered SPA tube. Analytical instrument: GC-VUV. Species analyzed: C3 to C8 hydrocarbons.
	Cold gas sample	Cold-dry gas: obtained after subjecting the product gas to scrubbing in isopropanol quench at -17 °C. Analytical instrument μ GC1: micro-GC Varian Model CP4900, with Poraplot Q and MS5A columns. He and Ar as carrier gas, respectively. Species analyzed: He, H ₂ , CO, CO ₂ , CH ₄ , C ₂ H ₂ , C ₂ H ₄ , C ₂ H ₆ , C ₃ H ₆ , C ₃ H ₈ , N ₂ , and O ₂ . Analytical instrument μ GC2: micro-GC Varian model CP4900. MS5A and Poraplot U columns. Ar and He as carrier gas, respectively. Species analyzed: He, H ₂ , CO, CO ₂ , CH ₄ , C ₂ H ₂ , C ₂ H ₄ , C ₂ H ₆ , C ₃ H ₆ , N ₂ , and O ₂ .
Slipstream 2	High temperature reactor (HTR)	

VUV for both SPA and gas samples is provided in Table 2.

The gas samples were injected into the GC-VUV either two or three times, utilizing different split ratios of 1:6, 1:8, and 1:10. This approach allowed for the quantification of trace species present in the gas samples while avoiding detector saturation caused by higher-concentration species. In contrast, the eluted SPA samples were injected into the GC-VUV system only once, using a split ratio of 1:12, as outlined in Table 2. This specific split ratio was determined to be suitable for the analysis of the SPA samples. Following this approach, the GC-VUV system has the capability to detect and quantify all hydrocarbon species within the boiling point range of C6 to C18 for SPA samples and C3 to C8 for gas samples.

To determine the mass composition of the samples, the VUV Analyze software (version 1.8.1) developed by VUV Analytics, Inc. in Texas, United States, was utilized. This software takes into consideration the

Table 2
Technical description of the analysis methods employed on GC-VUV.

	SPA samples	Gas Samples
Column description	ZB-1HT (30 m × 0.32 mm × 0.10 μ m)	CP-Si15 CB (25 m × 0.25 mm × 1.2 μ m)
Capillary tubing	Dimethylpolysiloxane	Fused silica
Polarity	Non-polar	Non-polar
Injector temperature	350 °C	140 °C
Detector temperature	325 °C	325 °C
Column flow	2 ml/min H ₂ , constant	2.56 ml/min H ₂ , constant
Split ratio	1:12	1:6/1:8/1:10
Initial temperature	35 °C	35 °C
Initial hold time	0 min	1 min
Temperature ramp	10 °C/min	30 °C/min
Target temperature	300 °C	102.5 °C
Final hold time	0 min	0/1 min
Total time	32 min	3.5/4.5 min
Species range	C6 to C18	C3 to C8

relative response factors (RRF) for each of the species present in the gas sample to determine the mass composition of the sample [25]. Supplementary information Table S4 provides the RRFs for the species quantified in this study.

To obtain cold gas samples, the product gas was subjected to a scrubbing process using isopropanol at a temperature of -17 °C. This scrubbing procedure took place within a quench bottle, as depicted in Fig. 4. The purpose of this step was to eliminate condensable hydrocarbons and steam from the gas mixture, ensuring that the resulting gas sample was cold-dry. The cold gas samples were then directed into a micro-GC system, which measured the volumetric composition of the gas mixture at intervals of 3 min. The 3-min time interval was determined by the runtime of the method used in the micro-GC system, enabling the measurement of carbon species ranging from C1 to C3. For further insights and a more comprehensive understanding of the isopropanol quench system used in this study, readers can refer to the work conducted by Larsson et al. [30].

The second slipstream is directed toward a high-temperature reactor (HTR), where the total amounts of carbon (C), hydrogen (H), and oxygen (O) present in the hot product gas are quantified. Inside the HTR, the product gas is heated to a temperature of 1700 °C, causing the decomposition of all hydrocarbons into CO₂, carbon monoxide CO, and H₂. These decomposition products are monitored online with the micro-GC system to calculate the elemental flows of C, H, and O that exit the steam cracker. The ability of the micro-GC (μ GC2) system to measure various hydrocarbons (refer to Table 1) enables the verification of the complete conversion of the cracker effluent to syngas within the HTR. For a more detailed understanding of the HTR's configuration and comprehensive mass balance calculations, readers are advised to refer to the work performed by Israelsson et al. Israelsson et al. developed the HTR method to validate carbon yield in thermochemical processes [38]. Additionally, this method facilitates the indirect estimation of C4+ species, providing a means to validate results obtained through GC-VUV analysis.

Sampling from the two slipstreams in parallel provides a means to validate the carbon balance closure achieved during the experiment. By accurately sampling and quantifying all the species present in the product gas mixture, the carbon balance obtained from both slipstreams should be equal. To determine the amount of species not measured with slipstream 1, Eq. (1) can be utilized.

$$\%C_{\text{unspecified}} = \%C_{\text{HTR}} - \%C_{\text{slipstream1}} \quad (1)$$

In this equation, $\%C_{\text{unspecified}}$ represents the carbon balance corresponding to the unmeasured species, $\%C_{\text{HTR}}$ denotes the carbon balance obtained using HTR, and $\%C_{\text{slipstream1}}$ represents the carbon balance derived from the various measurement techniques employed for slipstream 1.

Table 3
Summary of the experimental matrix, operating conditions and the employed analytical methods.

Test	Temperature (°C)	Feed flow (kg/h)	μGC1	GC-FID	GC-VUV		μGC2
			Cold gas	SPA (x2) ^a	Gas bag	Hot gas	
T1	759	91.2	✓	✓			✓
T2	812	91.2	✓	✓			✓
T3	819	91.2	✓	✓			✓
T4	793	90.0	✓	✓	✓		✓
T5	767	78.7	✓	✓	✓		✓
T6	797	78.7	✓	✓	✓		✓
T7	807	78.7	✓	✓	✓		✓
T8	815	63.7	✓	✓	✓	✓	✓
T9	814	78.7	✓	✓	✓	✓	✓
T10	795	78.7	✓	✓	✓	✓	✓

^a ‘SPA (x2)’ represents sampling with a series of 2 double layered SPA columns.

^b ‘SPA (x1)’ represents sampling with one single layered SPA column.

3.3. Experimental matrix

The experimental matrix involved conducting 10 tests that incorporated changes in both the feed flow to the steam cracker and the cracking temperature. These variations were implemented to achieve a wide range of cracking severity, ultimately leading to a broader distribution of products. Each test involved a stable operation lasting between 30 and 60 min, during which various samples were extracted from the two slipstreams discussed earlier. Table 3 provides a concise summary of the experimental tests (T1 to T10) along with the sampling and analytical techniques employed for each test.

3.4. Data evaluation

The results of this study are presented in the form of a carbon balance over the steam cracker. The carbon balance is calculated by summing the contribution (%carbon, by weight) of all carbon-containing species ranging from C1 to C18. By reporting the results in terms of %carbon, a clear understanding of the product distribution can be obtained, considering that the feedstock primarily consists of carbon (84 wt%) and hydrogen (15 wt%). Additionally, this approach helps determine the quantity of species that were not measured by the employed analytical methods, as shown in Eq. (1).

The contribution of species measured by μGC1 and μGC2 to the carbon balance is determined using the He-tracing method, as outlined in Eq. (2). In this equation, %C_i represents the contribution of species *i* to the carbon balance, while %v_i represents the volumetric concentration of species *i* measured by the μGCs. The variables v_{He} and %v_{He} correspond to the flow and volumetric concentration, respectively, of the Helium tracer gas. The term \dot{m}_f denotes the mass flow of the feedstock supplied to the steam cracker. Furthermore, n_{C,i} denotes the number of carbon atoms present in one molecule of species *i*, n_{C,f} is the total moles of carbon present in 1 kg of feedstock, and V_m is the molar volume of ideal gas at 0 °C.

$$\%C_i = \left(\frac{\%v_i}{\%v_{He}} \right) \times \left(\frac{v_{He}}{\dot{m}_f} \right) \times \left(\frac{n_{C,i}}{n_{C,f}} \right) \times \frac{1}{V_m} \times 100 \quad (2)$$

The mass concentrations of the species measured by GC-VUV in the gas samples are converted into their corresponding carbon balance contributions using Eq. (3). This equation considers the mass concentration of species *i* (%m_i) and C₃H₆ (%m_{C₃H₆}) in the gas sample, which are obtained by processing the respective chromatograph using the VUV Analyze software. The variable MW_i represents the molecular weight of species *i*. The term %C_{C₃H₆} denotes the carbon balance contribution of C₃H₆ and is obtained using Eq. (2). C₃H₆ serves as the reference species in Eq. (3) because it is a common component that can be measured using both μGC1 and GC-VUV techniques.

$$\%C_i = \left(\frac{\%m_i}{\%m_{C_3H_6}} \right)_{VUV} \times \left(\frac{MW_{C_3H_6}}{MW_i} \right) \times \left(\frac{n_{C,i}}{n_{C,C_3H_6}} \right) \times \%C_{C_3H_6} \quad (3)$$

The quantification of the species sampled using the SPA method is determined based on the procedure established by Israelsson et al. [28]. This standardized procedure remains consistent regardless of whether the analysis is performed using GC-FID or GC-VUV.

4. Results and discussion

The results obtained in this work are presented with respect to the total carbon present in the feedstock (%carbon). In the following sections, the outcomes achieved through the various individual sampling and analysis methods applied in this study are detailed. The validation of the GC-VUV results through their comparison with the other techniques is detailed within this section, following the presentation of results.

4.1. GC-TCD (μGC2, HTR)

The high-temperature reactor (HTR) system is coupled to the Chalmers steam cracker to measure the total amount of carbon present in the product gas mixture. Illustrating the outcome of this measurement, Fig. 5 displays the yield (%carbon) of total gas calculated based on the volumetric composition of the HTR effluent gas. This yield

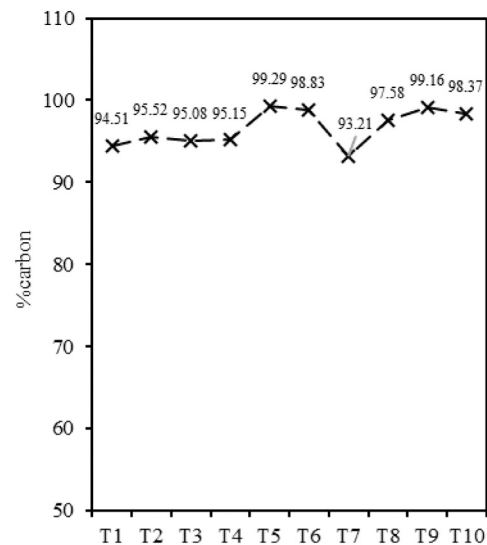

Fig. 5. The carbon content (%carbon) recovered as gas mixture at the exit of the steam cracker relative to the carbon content of the feedstock for tests T1 through T10.

corresponds to the total carbon content within the gas mixture at the outlet of the steam cracker, relative to the total carbon content in the feedstock.

The data presented in Fig. 5 is derived from the average of ten chromatographs obtained through $\mu\text{GC}2$ during the stable operation of each respective test. To reevaluate these outcomes, Eq. (2) can be used along with the original chromatograph data provided in Table S5 (supplementary information).

The amount of carbon, in the form of polyethylene, introduced into the steam cracker is recovered as a product gas mixture, and the recovery rate falls in the range of 93 to 99%, as shown in Fig. 5. The remaining portion of carbon is carried over to the boiler section of the system by the circulating bed material. There, this carbon fraction burns in the presence of air. This stated carbon recovery rate serves as a means to validate the total product yield obtained with different measurement techniques applied at slipstream 1. In principle, the total product yield, determined by quantifying all the species present in the product mixture, should be equivalent to the yield measured using HTR. The following sections present the yields of individual species found in the product gas mixture, which were obtained using various sampling and analysis techniques employed at slipstream 1.

4.2. GC-TCD ($\mu\text{GC}1$)

The volumetric composition of cold-dry gas was measured using $\mu\text{GC}1$ at regular intervals of 3 min over a 30-min time period. To gain insights into a typical stable operation, Fig. 6 illustrates the stable operations achieved during tests T1 and T4. These visualizations help to understand the consistency and performance of the process during the given time frame.

Fig. 6 provides a clear representation of the stable operations observed during tests T1 and T4. These tests offered a reasonable time window of stable operation, with an averaged relative standard deviation of $\sim 2.5\%$, allowing for the extraction of different samples. The stability of the operation for a 30-min period ensured that the samples could be fairly compared despite being extracted at different times. To gain a broader understanding, supplementary information Table S6 provides the data representing the rest of the tests.

The carbon balance contribution of the species measured by $\mu\text{GC}1$ can be determined by applying the data from Table S6 (supplementary information) to Eq. (2). Fig. 7 visualizes the outcomes, presenting the shares of carbon balance corresponding to the species present in the cold-dry gas obtained through GC-TCD ($\mu\text{GC}1$) analysis. Fig. 7 also illustrates the portion of the total product gas mixture that is obtained as

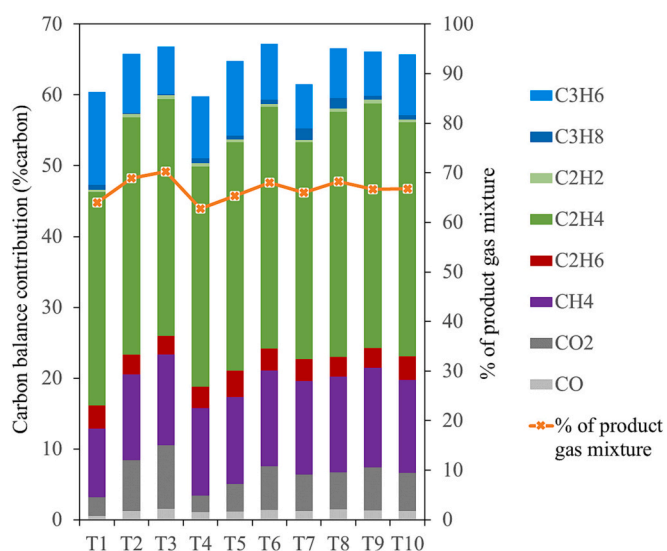

Fig. 7. Carbon balance contributions of the species present in the cold-dry gas, calculated based on GC-TCD analysis. The secondary axis represents the % of total product gas obtained as cold-dry gas.

cold-dry gas.

The proportion of the total product gas mixture obtained as cold-dry gas falls within the range of 60–70%. It's important to note that this represents a portion of the total gas mixture at the outlet of the reactor. This portion is determined by normalizing the total carbon yield (% carbon) obtained through cold-dry gas sampling to the results obtained from HTR measurements (Eq. (4)).

$$\% \text{ of product gas mixture} = \frac{\% \text{ carbon}_{\text{cold-dry gas}}}{\% \text{ carbon}_{\text{HTR}}} \times 100 \quad (4)$$

Among the species present in the cold-dry gas mixture, ethylene accounted for the highest yield, comprising approximately 30% to 35% of the total carbon content of the feedstock. Following closely behind was methane, constituting around 10% to 15%, and propylene with approximately 6% to 13% (%carbon). Interestingly, this range of carbon yield closely resembles the typical product distribution obtained from a naphtha cracking process, which is considered to be the optimal operational window for ethylene and propylene production [1,5,8]. Furthermore, earlier investigations into fluidized bed pyrolysis/steam

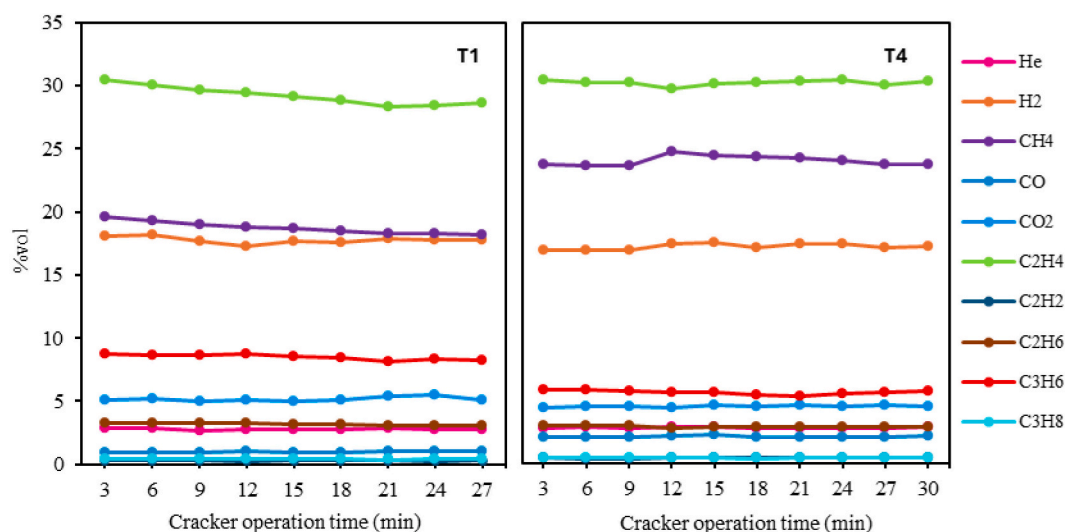

Fig. 6. Volumetric composition of the cold-dry gas measured by $\mu\text{GC}1$ every 3 min over the stable operations achieved during tests T1 and T4.

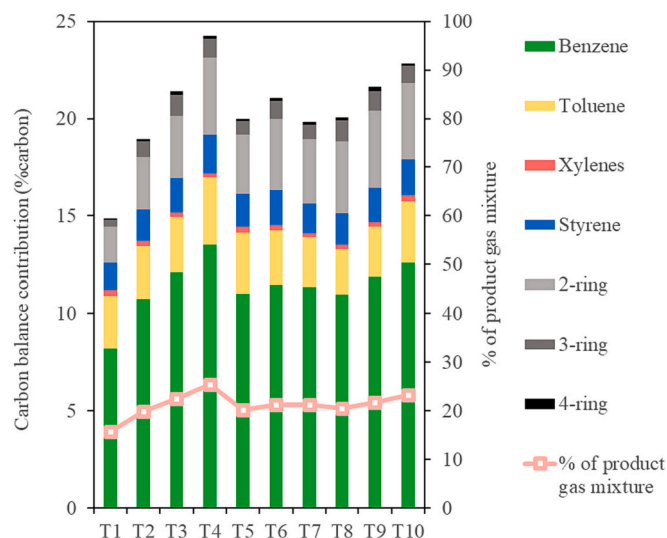

Fig. 8. Carbon balance contributions of the species samples using SPA (x2), calculated based on GC-FID analysis. The secondary axis represents the % of total product gas adsorbed onto the SPA columns.

cracking of polyethylene have yielded C2 and C3 species in the range of 25% to 35% and 10% to 20% (%carbon), respectively, at reactor temperatures similar to those employed in this study [10,13,31].

4.3. GC-FID

The SPA (x2) samples (a series of two double-layered SPA columns) were subjected to GC-FID analysis using the methodology established by Israelsson et al. The GC-FID method developed by Israelsson et al. involves quantification of certain aromatic species in the boiling point range of C6 to C18 [28]. Fig. 8 displays the carbon balance contributions associated with the aromatic species that were sampled using SPA (x2) in tests T1 through T10. Furthermore, the portion of the product gas that is adsorbed onto the SPA columns can be visualized by referring to the secondary axis of Fig. 8. This portion is also calculated by normalizing the carbon yields (%carbon) to the HTR results (Eq. (4)).

The diverse operating conditions employed across tests T1 to T10 result in a considerable range of aromatic yields, falling within the range of 16% to 25% (%carbon). This observed range aligns with previously reported findings in the literature concerning polyethylene pyrolysis/steam cracking within fluidized beds operating at temperatures comparable to those utilized in this study [4,9,10,13].

Within the aromatic species examined, benzene emerges as the most prominent contributor, accounting for 8% to 14% of the total carbon content of the feedstock. Subsequently, toluene and styrene follow suit in their contributions, accounting for 2% to 4% and 1% to 3% of the overall carbon balance, respectively. Furthermore, polyaromatic species, encompassing 2, 3, and 4-membered ring species, contribute around 2% to 6% to the overall carbon balance.

4.4. GC-VUV

The GC-VUV analysis was performed on three different types of samples: gas bag, hot gas sample, and SPA. The results obtained from the analysis of each of these samples are presented in the following sections.

4.4.1. Gas bag analysis with GC-VUV

During tests T4 through T10, gas bag samples were collected and subjected to analysis using GC-VUV. The analysis involved injecting each gas bag into the GC-VUV using either two or three different split ratios, as outlined in Table 2. Fig. S1 (supplementary information) displays the chromatographs obtained from the GC-VUV analysis of a gas

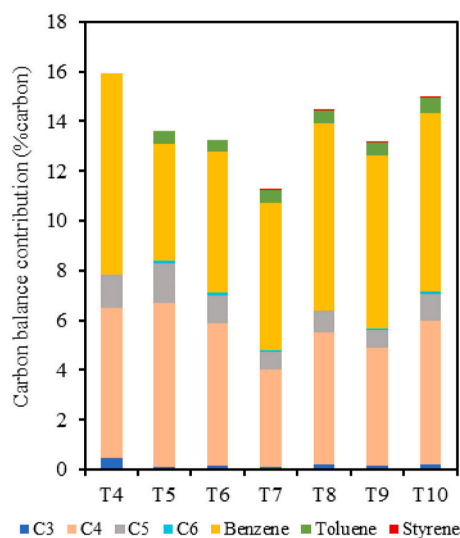

Fig. 9. Carbon balance contribution of the species present in the gas bags, calculated based on GC-VUV analysis. C3 represents C_3H_4 , and C4 – C6 represents all aliphatic and naphthenic hydrocarbons in that range.

bag sample collected during test T10, specifically using split ratios of 1:10 and 1:8.

Fig. S1 clearly demonstrates that using a split ratio of 1:8 during sample injection enables the detection of low concentration species that remain undetected when using the split ratio of 1:10. Moreover, the VUV Analyze software's deconvolution capability reduces the time requirement compared to other analytical techniques [25,26]. For instance, in the current study, the TCD analysis took approximately 3 min to analyze species in the C1 to C3 range. In contrast, the GC-VUV analysis provides quantification of hydrocarbon species in the C3 to C8 range in just 4 min. Fig. 9 displays the carbon balance contribution of the species collected in the gas bag samples, analyzed by the GC-VUV method, as calculated using Eq. (3).

In Fig. 9, C_3H_4 is presented as C3, aliphatic and naphthenic species are grouped as C4, C5, and C6, while the aromatic species benzene, toluene, and styrene are shown separately. The carbon balance corresponding to the measured species in the gas bags falls within the range of 11–16% (%carbon) for tests T4 through T10. Among the aliphatic and naphthenic species, C4 represents the majority of the share, accounting for 4–7% of the total, followed by C5 with approximately 1%, and C6 with around 0.05%. No aliphatic and naphthenic species within the C7 to C8 range were detected in any of the gas bag samples.

Among the aromatic species, benzene exhibits the highest share (5 to 8%), with toluene (~0.5%) and styrene (~0.05%) following suit in decreasing order. Table S7 (supplementary information) provides mass compositions of individual species, as derived from the VUV Analyze software. Using Eq. (3) and the results reported in Table S7, one can calculate the carbon balance contributions of the individual species.

4.4.2. Hot gas analysis with GC-VUV

During tests T8, T9, and T10, samples of hot gas were collected within the heated gas sampling cylinder and subsequently subjected to GC-VUV analysis. As previously mentioned, the use of the single-layered SPA amine column facilitated the sampling of monoaromatics (BTXS) downstream of the amine column. This arrangement allowed for the collection of BTXS species within the heated vessel and the gas bag connected downstream of the single-layered SPA column (see Fig. 4).

The GC-VUV analysis conducted on the hot gas samples obtained from the heated vessel included the identification and quantification of species in the C6 to C8 hydrocarbon range. This quantification was carried out to ensure a fair and accurate comparison with the yields obtained from the corresponding gas bags. In Eq. (3), cyclopentadiene

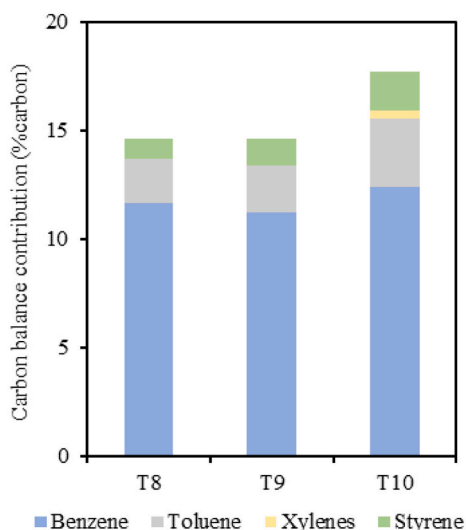

Fig. 10. Carbon balance contribution of the species sampled in the heated sampling vessel, calculated based on GC-VUV analysis.

was utilized as the reference species for carbon balance contribution calculations, as it was measured in both the gas bags and hot gas samples. The quantification of C3 and C4 species was not viable due to the significant presence of steam in the hot gas samples.

The data presented in Fig. 10 illustrates the carbon balance contribution of the C6 to C8 species collected within the heated vessel. This contribution was determined through the application of Eq. (3) and provides valuable insights into the yields of C6 to C8 species in the sampled gases.

The carbon balance contribution associated with the C6 to C8 species, as determined through hot gas analysis, falls within a range of 14–18%. It's important to highlight that exclusively BTXS species were detected in the hot gas sample. Within the BTXS category, benzene emerges as the most significant contributor, constituting approximately 12% of the overall carbon balance. Toluene and styrene follow in contribution, exhibiting a similar trend to the findings obtained from the GC-VUV analysis of the gas bags, as outlined in the preceding section. Additionally, the presence of xylenes was only detected within the hot gas sample collected during test T10, amounting to 0.3% of the carbon balance.

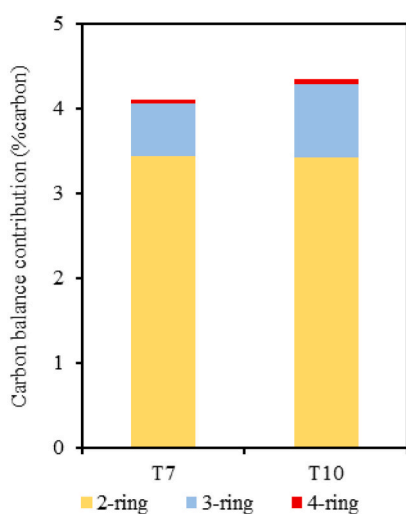

Fig. 11. Carbon balance contribution of the species sampled through SPA (x1), calculated based on GC-VUV analysis. The species sampled through SPA (x1) are grouped as 2-ring, 3-ring and 4-ring polycyclic aromatic hydrocarbons.

4.4.3. SPA analysis with GC-VUV

The SPA (x1) samples (one single-layered SPA column) obtained from tests T7 and T10 underwent GC-VUV analysis for the quantification of hydrocarbon species in the range of C6 to C18. A visual representation of the contribution to the carbon balance by these species, is presented in Fig. 11.

Fig. 11 clearly illustrates that only polyaromatic species featuring 2, 3, and 4-ring aromatic structures were identified with GC-VUV analysis of SPA (x1) samples. This limitation arises from the single-layered SPA columns being unable to adsorb monoaromatic BTXS species [28]. Additionally, the analysis did not detect any aliphatic or naphthenic species within the same range of C6 to C8. As a result, Fig. 11 effectively represents the yield of C9 to C18 in the form of carbon balance contributions.

The polyaromatic compounds accounted for 4.45% and 4.49% of the overall carbon balance in tests T7 and T10, respectively. Analyzing the breakdown of these polyaromatics, 2-ring compounds, including naphthalene and its derivatives, held the predominant portion at 3.44% for T7 and 3.42% for T10. Meanwhile, the contribution of 3-ring and 4-ring compounds was notably minor, constituting approximately 1% and 0.1% respectively, for both T7 and T10.

Table 4 enhances comprehension by presenting the absolute yields (% weight) of all measured species in relation to the employed process conditions. The reliability of these results is exemplified through accompanying error values associated with each measured species. These error values reflect the combined impact of both statistical and instrument errors for each data point. It is important to note that, for nearly all data points obtained in this study, the error remained consistently below 10%, underscoring the reliability of the findings.

The selection of GC-VUV analysis for this study stemmed from its capability to detect and quantify a wide spectrum of hydrocarbon species. By integrating GC-VUV and various sampling techniques, the limitations associated with the identification of numerous hydrocarbon species and the extended analysis time often seen in GC-TCD and GC-FID analysis were addressed. The results obtained through GC-VUV analysis can be validated by comparing them with the outcomes obtained using HTR analysis. Furthermore, the redundancy in the gas and SPA samples taken during select tests, which were subsequently subjected to both GC-VUV and GC-FID analyses, offers an additional avenue for result validation.

Conducting GC analysis on the cold-dry gas (using GC-TCD) and the SPA (x2) samples (using GC-FID) gives yields for compounds ranging from C1 to C3, as well as aromatic hydrocarbons from C6 to C18. Fig. 12 provides a visual representation of the portion of the total product gas mixture that is characterized by these two methods. Fig. 12 is essentially derived by combining the results from the right axis of Figs. 7 and 8.

The hydrocarbon species that are beyond the scope of the two aforementioned sampling and analysis techniques make up as much as 20% of the total product gas, as depicted in Fig. 12. These particular species, which are denoted as “unspecified” in Fig. 12, consist specifically of C4+ aliphatic and naphthenic hydrocarbons. Among these species, C4 and C5 hydrocarbons are excluded from sampling in both the cold-dry gas as well as the SPA (x2) samples due to their boiling points. Aliphatic and naphthenic hydrocarbons from C6 and above can be sampled using SPA (x2). However, quantifying them with GC-FID necessitates the identification and calibration of these numerous hydrocarbons.

The yield of the species within the unspecified portion (as shown in Fig. 12) of the product gas can be assessed through HTR analysis using Eq. (1). Moreover, these estimated yields can serve as a means to validate the yields of C4+ aliphatic and naphthenic species acquired through GC-VUV analysis. Fig. 13 illustrates the comparison between the unspecified species estimated with the HTR method and those measured through GC-VUV analysis of gas bag samples obtained during tests T4 through T10.

Evidently from Fig. 13, the results obtained for C4+ species through

Table 4

Absolute yields (% weight) of measured species in steam cracker effluent, alongside associated error values, across varied operating conditions investigated in this study.

	T1	T2	T3	T4	T5	T6	T7	T8	T9	T10
Temperature (°C)	759	812	819	793	767	797	807	815	814	795
Feed flow (kg/h)	91.2	91.2	91.2	90	78.7	78.7	78.7	63.7	78.7	78.7
Yield (%wt.)										
H ₂	1.32	2.23	3.01	1.27	1.19	1.48	1.43	1.28	1.54	1.30
±	0.02	0.03	0.06	0.01	0.02	0.03	0.03	0.08	0.02	0.05
CH ₄	11.08	13.79	14.66	14.15	14.04	15.46	15.19	15.49	16.12	15.07
±	0.34	0.32	0.32	0.22	0.41	0.36	0.27	0.29	0.27	0.09
CO	1.03	2.41	3.15	2.19	2.27	2.78	2.51	2.94	2.62	2.40
±	0.03	0.08	0.12	0.04	0.05	0.09	0.08	0.14	0.07	0.04
CO ₂	8.37	22.72	28.04	7.33	12.39	19.38	15.99	16.40	19.04	16.89
±	0.23	0.66	0.48	0.09	0.37	0.49	0.52	1.86	0.36	0.54
C ₂ H ₂	0.29	0.49	0.53	0.40	0.30	0.40	0.31	0.45	0.45	0.32
±	0.01	0.02	0.01	0.01	0.01	0.03	0.01	0.04	0.02	0.01
C ₂ H ₄	30.21	33.50	33.44	31.13	32.31	34.12	30.65	34.62	34.58	33.10
±	0.94	0.75	0.83	0.47	0.94	0.80	0.62	0.73	0.44	0.31
C ₂ H ₆	3.51	3.07	2.90	3.23	4.00	3.36	3.29	3.02	3.02	3.61
±	0.13	0.07	0.09	0.09	0.14	0.09	0.08	0.14	0.06	0.06
C ₃ H ₄ ^a	n.d.	n.d.	n.d.	0.42	0.08	0.15	0.09	0.21	0.17	0.22
±				0.01	0.01	0.02	0.01	0.02	0.01	0.01
C ₃ H ₆	13.18	8.33	6.71	8.73	10.56	7.94	6.19	7.03	6.24	8.57
±	0.47	0.19	0.46	0.33	0.51	0.32	0.24	0.28	0.17	0.38
C ₃ H ₈	0.70	0.13	0.13	0.76	0.64	0.63	1.74	1.56	0.60	0.69
±	0.03	0.01	0.01	0.04	0.06	0.05	0.22	0.28	0.16	0.25
C ₄ ^a	n.d.	n.d.	n.d.	5.84	6.41	5.50	3.95	5.12	4.54	5.57
±				0.62	0.20	0.11	0.28	0.16	0.02	0.06
C ₅ ^a	n.d.	n.d.	n.d.	1.30	1.51	1.12	0.70	0.71	0.66	0.99
±				0.01	0.01	0.01	0.02	0.01	0.01	0.02
C ₆ ^a	n.d.	n.d.	n.d.	0.00	0.10	0.05	0.02	0.03	0.04	0.10
±					0.01	0.01	0.01	0.02	0.02	0.01
Benzene	7.62	10.00	11.24	12.54	10.23	10.65	10.54	10.84 ^b	10.43 ^b	11.52 ^b
±	0.44	0.19	0.20	0.01	0.13	0.85	1.15	0.31	0.11	0.59
Toluene	2.52	2.52	2.66	3.25	2.92	2.60	2.39	1.87 ^b	2.00 ^b	2.98 ^b
±	0.11	0.08	0.01	0.08	0.05	0.22	0.25	0.05	0.02	0.15
Xylenes	0.31	0.25	0.22	0.18	0.31	0.27	0.20	0.00 ^b	0.00 ^b	0.18 ^b
±	0.02	0.01	0.01	0.01	0.01	0.03	0.02			0.01
Styrene	1.26	1.51	1.65	1.89	1.56	1.68	1.41	0.88 ^b	1.18 ^b	1.66 ^b
±	0.08	0.05	0.01	0.04	0.02	0.14	0.17	0.03	0.02	0.08
2-ring	1.72	2.49	2.94	3.63	2.80	3.35	2.31 ^b	3.38	3.64	2.83 ^b
±	0.08	0.08	0.10	0.10	0.04	0.33	0.92	0.41	0.06	0.30
3-ring	0.31	0.71	0.95	0.88	0.63	0.81	0.55 ^b	0.95	0.92	0.78 ^b
±	0.02	0.02	0.16	0.08	0.04	0.15	0.30	0.08	0.08	0.12
4-ring	0.07	0.14	0.20	0.12	0.11	0.15	0.02 ^b	0.16	0.18	0.04 ^b
±	0.01	0.01	0.01	0.01	0.02	0.02	0.01	0.01	0.01	0.02

n.d.: not detected.

^a Species measured only with GC-VUV.

^b Species measured with GC-VUV and GC-FID. Presented values are calculated based on GC-VUV measurements.

GC-VUV analysis align closely with the values estimated through HTR for the majority of data points, except T5 and T7. Across the remaining data points, the difference between estimated and measured values remains under 3% (%carbon), with measured values consistently falling below the estimated figures. For the data points T5 and T7, GC-VUV analysis underestimates C₄+ species by 3.5% and 5.4%, respectively. This could potentially be attributed to either sampling errors or the presence of C₆+ species in the product mixture, which were not captured in the gas bag samples.

The yield of monoaromatic species BTXS, as determined through GC-VUV analysis of gas bags and hot gas, can be validated by comparing it with the yields derived from GC-FID analysis of SPA (x2) samples. BTXS were sampled using all three of the aforementioned methods for tests T8, T9, and T10. Fig. 14 compares the BTXS yield as measured by GC-VUV and GC-FID analyses.

Fig. 14 illustrates that the GC-VUV analysis on gas bags yields the lowest amount of BTXS species. Remarkably, the BTXS yield obtained from GC-VUV analysis of gas bags is nearly half compared to the yield measured via GC-FID analysis of the SPA (x2) samples. Interestingly, the absence of xylenes and styrene is noticeable in the gas bag samples. These observations can potentially be attributed to the condensation of

BTXS species out of the gas phase. This is plausible considering that the gas bags were collected at the pressure side of the pump and stored at room temperature (25 °C).

In contrast to the VUV analysis of gas bags, the analysis of hot gas with VUV shows greater comparability with the corresponding GC-FID results. However, subtle differences in the yields of xylenes and styrene can be seen in Fig. 14. Particularly, lower quantities of xylenes and styrene are obtained through VUV analysis of the hot gas when compared to the GC-FID results. These observations can be attributed to the relatively low concentrations of styrene and xylenes within the product mixture, as well as the influence of water vapor in the hot gas sample, which contributes to the dilution of these species. Nevertheless, it's important to note that the underestimation of styrene and xylenes accounts for less than 1% of the carbon balance.

Transitioning to the last category of species assessed through GC-VUV, the yield of polyaromatics can similarly be validated through a comparison with the corresponding GC-FID findings. The measurement of polyaromatic species using both VUV and FID approaches was redundantly conducted during tests T7 and T10. The comparison of the yields of polyaromatic species, as measured by GC-VUV and GC-FID, is depicted in Fig. 15 for T7 and T10.

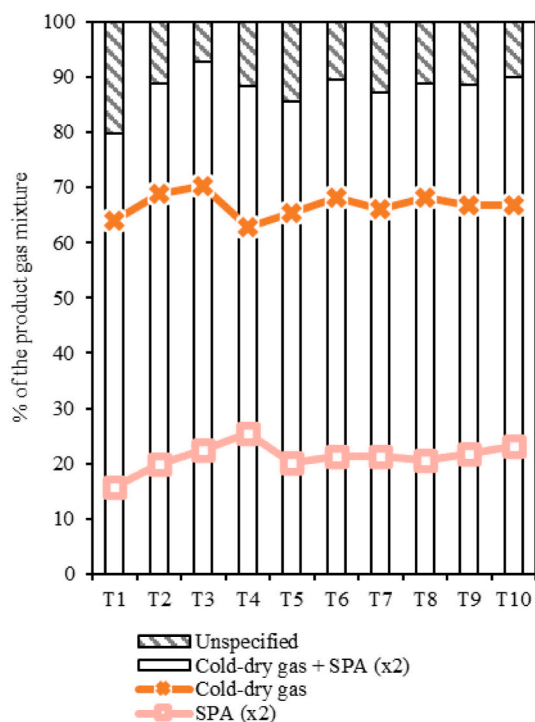

Fig. 12. The portion of the product gas that undergoes sampling as cold-dry gas, and SPA (x2), characterized by GC-TCD and GC-FID, respectively. The unspecified part represents the fraction of the product gas that is not sampled by either of these two techniques.

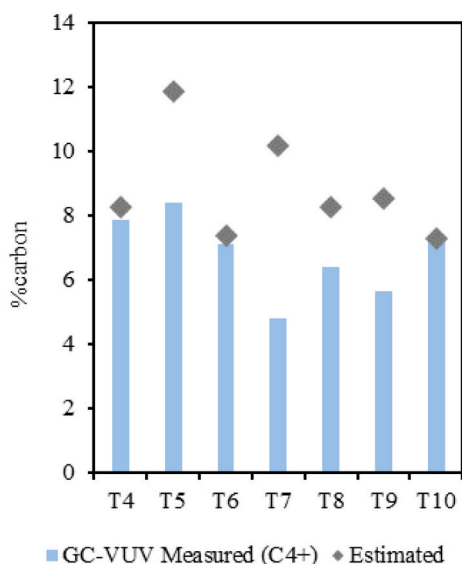

Fig. 13. Comparison of C4+ aliphatic and naphthenic species measured by GC-VUV analysis and their estimation using HTR analysis. The difference between the estimated and the measured values represents the unmeasured amount of C4+ species.

The comparison between polyaromatic yields acquired from GC-VUV and GC-FID measurements of the SPA samples demonstrates a notable degree of similarity, as shown in Fig. 15. However, subtle deviations are apparent, with GC-VUV indicating yields 0.1% and 0.5% (%carbon) lower than those registered by GC-FID for T7 and T10, respectively. This is due to GC-VUV underestimating 3-ring and 4-ring species in both T7 and T10 when compared to GC-FID. Additionally, the yield of 2-ring species is underestimated in T10 when analyzed with GC-VUV. Similar

to xylenes and styrene, which experienced slight underestimation through VUV analysis, the underestimation of these polyaromatics also contribute less than 1% to the carbon balance.

From the discussion above, it is clear that GC-VUV provides reliable carbon balance closure for a steam cracking process. For the quantification of the complete spectrum of hydrocarbons within the product mixture, GC analysis becomes the time determining step. Fig. 16 shows a comparison of the carbon balance closure and characterization times for the different sampling and analysis techniques used in this work using test T10 as the reference.

According to the last bar (SPA x2) of Fig. 16, in the absence of GC-VUV analysis, an unspecified species portion exceeding 10% of the carbon balance emerges, attributed to the C4+ aliphatic and naphthenic species. However, these unspecified species can be effectively sampled via gas bags and quantified using GC-VUV within a mere 3-min analysis window. From a time-perspective, the measurement of aromatic species utilizing GC-FID takes a substantial 180 min yet ensures precise determination of C6 to C18 aromatic compounds. Alternatively, employing GC-VUV with hot gas and SPA (x1) sampling reduces the analysis time to 26 min, with a small trade-off involving marginal underestimation (around 1%carbon), compared to GC-FID analysis, of low-concentration species like xylenes and polyaromatics.

It is evident that the ability to quantify trace species like the C6+ aliphatics and naphthenes, xylenes and PAHs faces limitations. This is primarily attributed to the configuration of the Chalmers steam cracker, which necessitates a minimum steam input of 185 kg/h into the reactor, thereby resulting in relatively low hydrocarbon concentrations within the product mixture. It's important to underline that these constraints hold lesser relevance for industrial processes where steam's partial pressure can be notably lower compared to the conditions observed in the Chalmers reactor [2,3].

The sampling strategies employed for GC-VUV analysis in this study primarily involve offline sampling techniques, such as the use of gas bags, hot gas vessels, and SPA samples. It is important to note that the manual nature of these sampling procedures introduces the potential for overall measurement errors. These errors may stem from issues related to the handling and storage of the samples. Furthermore, the precision of the sampling process depends on the individuals responsible for collecting the samples.

Despite the limitations associated with manual sampling techniques, the application of GC-VUV analysis resulted in a verified carbon balance closure of up to 98%. To address the challenges posed by manual sampling, an online sampling system, as demonstrated by Pyl et al. [20], should be integrated with GC-VUV. For example, the cracker effluents can be dehydrated and quenched to the dew point of C8 hydrocarbon before injecting it into the GC-VUV system. By incorporating such an online system, the real-time quantification of species up to C8 can be achieved within just 4 min. Additionally, such a sampling system could address the difficulty in quantifying trace species within the C7 and C8 hydrocarbon range.

Given that the characterization of C8+ hydrocarbons is a time-intensive step, it is recommended to conduct this analysis offline. This approach ensures that the characterization of heavier hydrocarbons does not impede the analysis of lighter and more crucial species within the product mixture. By separating the characterization of C8+ hydrocarbons, the focus remains on the primary components without compromise. Furthermore, adopting an offline sampling strategy eliminates the constraint on the number of samples that can be taken during a stable operation of the cracker.

The scope of the current study is confined to the characterization of the product mixture derived from steam cracking of polyethylene. Nonetheless, as shown here, the introduction of three complementary sampling steps (see Fig. 2) in this research presents an opportunity to comprehensively analyze carbon species spanning from C1 to C18. It is important to note that the method's potential is amplified by the VUV detector's ability to identify and quantify a wide spectrum of

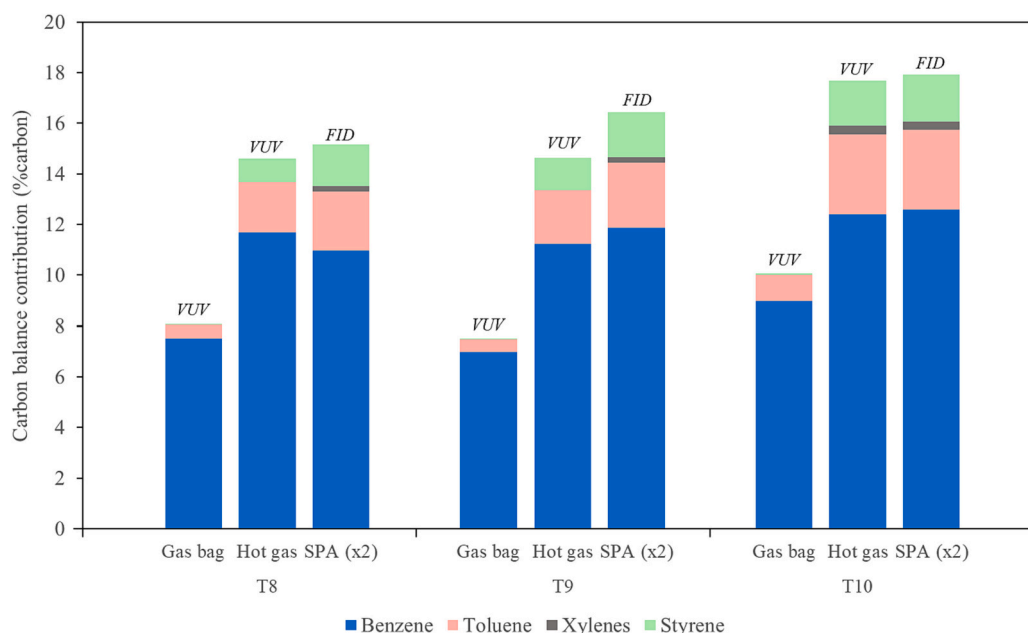

Fig. 14. Comparison of the yields (%carbon) of BTXS species measured by GC-VUV and GC-FID. GC-VUV analysis was performed on gas bag and hot gas samples. GC-FID analysis was performed on SPA (x2) samples.

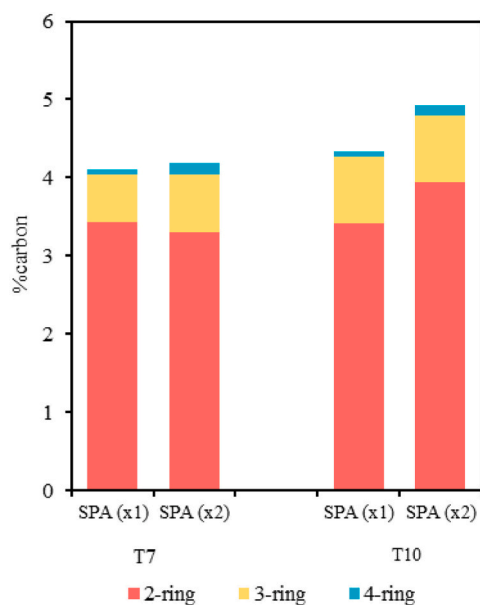

Fig. 15. Comparison of the yields of polyaromatic species measured by GC-VUV and GC-FID. One single layered SPA column (SPA (x1)) was sampled for GC-VUV analysis. A series of two double layered SPA columns (SPA (x2)) was sampled for GC-FID analysis.

hydrocarbons. The application of the method outlined here holds promise for steam crackers utilizing a diverse range of feedstocks, ranging from uncomplicated options like petroleum naphtha to more intricate alternatives like mixed plastic waste [6,8].

The findings of our research hold significant implications for industrial processes, particularly in the context of a steam cracking process dedicated to plastic waste. The variations in the quality of collected plastic waste, can lead to fluctuations in the composition of the cracker effluent. The proposed analytical strategy presented in this work offers a practical solution by enabling the swift detection of changes in product composition. Furthermore, the utilization of VUV absorption spectra

adds another layer of practicality. The spectra not only aid in detecting changes in hydrocarbon composition but also enable the identification of hydrocarbons with heteroatoms. This is particularly relevant as certain types of plastic materials may produce hydrocarbons with heteroatoms during the cracking process.

5. Conclusions

This study addressed several key challenges associated with characterizing the product mixture obtained from a steam cracking process. Cooling, scrubbing, and adsorption were introduced as sampling steps to cover the hydrocarbon species of the gas product ranging from C1 to C18. Subsequently, the sampling steps were coupled to GC-TCD, GC-FID and GC-VUV analysis as characterization methods for the quantification of the sampled species. The results, in terms of measured carbon content and characterization time, were comparatively evaluated with a special focus on the GC-VUV outcomes.

The findings underscore the pivotal role of GC-VUV in identifying and quantifying the species falling within the C4 to C18 range. This accounts for up to 35% of the carbon balance obtained during steam cracking of polyethylene, conducted at temperatures ranging from 750 °C to 850 °C. Notably, the quantification of C4 and C5 species occurred optimally when sampled via gas bags through a solid phase adsorption (SPA) column. Similarly, when compared with characterization by GC-FID, C6 to C8 species exhibited optimal quantification with GC-VUV when sampled gas, directed through an SPA column, was maintained at 60 °C before the injection into the GC. For species ranging from C9 to C18, adsorption onto the SPA column followed by GC-VUV analysis emerged as the preferred quantification method in terms of the overall characterization time.

The procedure detailed in this study highlights the quantification of C6 to C18 hydrocarbons as the time determining step. With GC-VUV, the quantification of this group of compounds is potentially accomplished within a brief 26-min analysis window. In contrast, the absence of GC-VUV leads to a noteworthy elongation of this time-critical step, extending the analysis duration to 180 min.

The current study is constrained by its reliance on offline sampling procedures and the utilization of a clean plastic feedstock. To enhance the applicability of the findings, future research should focus on

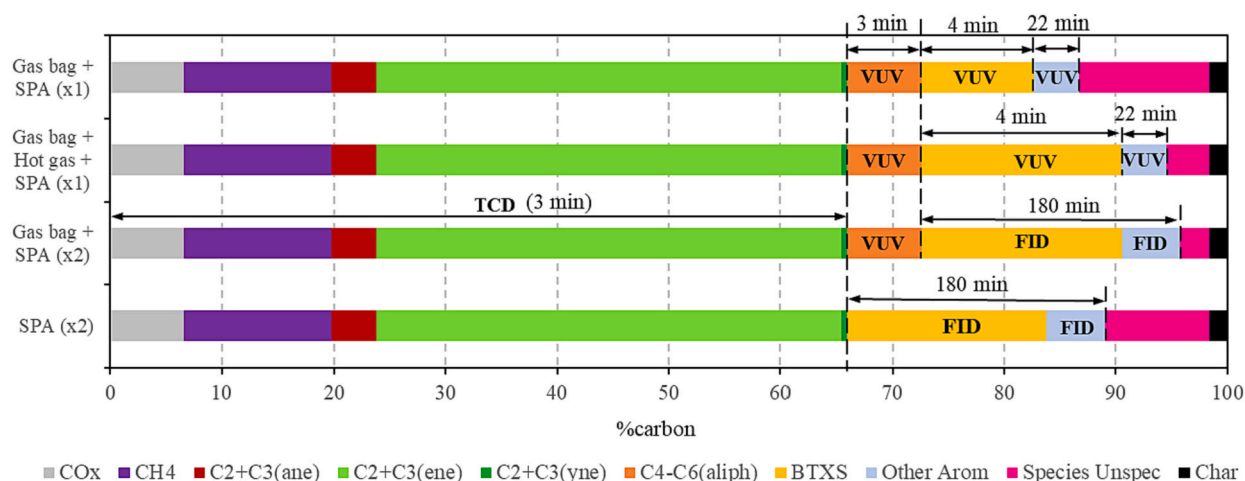

Fig. 16. Carbon balance closure achieved for test T10 with different sampling and analytical methods. The time windows represent the time required for respective GC analysis.

integrating GC-VUV with online sampling techniques. Moreover, expanding the scope of the study to include characterization of products obtained from steam cracking of real-life plastic waste is essential.

CRediT authorship contribution statement

Chahat Mandviwala: Writing – original draft, Methodology, Investigation, Data curation, Conceptualization. **Renesteban Forero Franco:** Methodology, Investigation, Data curation, Conceptualization. **Ivan Gogolev:** Methodology, Investigation, Conceptualization. **Judith González-Arias:** Methodology, Investigation. **Teresa Berdugo Vilches:** Supervision, Investigation, Conceptualization. **Isabel Cañete Vela:** Conceptualization, Investigation, Methodology. **Henrik Thunman:** Writing – review & editing, Supervision, Project administration, Conceptualization. **Martin Seemann:** Writing – review & editing, Funding acquisition, Conceptualization.

Declaration of competing interest

The authors declare that they have no known competing financial interests or personal relationships that could have appeared to influence the work reported in this paper.

Data availability

No data was used for the research described in the article.

Acknowledgments

This work was financially supported by Borealis AB (Project number: 49514-1), the Swedish Gasification Center (SFC) and the Swedish Energy Agency. The authors thank Jessica Bohwalli, Johannes Öhlin and Rustan Hvitt for technical support during the experiments.

Appendix A. Supplementary data

Supplementary data to this article can be found online at <https://doi.org/10.1016/j.fuproc.2023.108030>.

References

- Z. Gholami, F. Gholami, Z. Tişler, M. Vakili, A review on the production of light olefins using steam cracking of hydrocarbons, *Energies* (Basel). 14 (2021), <https://doi.org/10.3390/en14238190>.
- Ullmann's Encyclopedia of Industrial Chemistry, 2003, <https://doi.org/10.1002/14356007>.
- M. Kutz, *Appl. Plast. Eng. Handb.* (2011), <https://doi.org/10.1016/C2010-0-67336-6>.
- M.S. Abbas-Abadi, Y. Ureel, A. Eschenbacher, F.H. Vermeire, R.J. Varghese, J. Oenema, G.D. Stefanidis, K.M. Van Geem, Challenges and opportunities of light olefin production via thermal and catalytic pyrolysis of end-of-life polyolefins: Towards full recyclability, *Prog. Energy Combust. Sci.* 96 (2023), <https://doi.org/10.1016/j.pecs.2022.101046>.
- C. Mandviwala, J. González-Arias, M. Seemann, T. Berdugo Vilches, H. Thunman, Fluidized bed steam cracking of rapeseed oil: exploring the direct production of the molecular building blocks for the plastics industry, *Biomass Convers. Biorefin.* (2022), <https://doi.org/10.1007/s13399-022-02925-z>.
- I. Cañete Vela, T. Berdugo Vilches, G. Berndes, F. Johnsson, H. Thunman, Co-recycling of natural and synthetic carbon materials for a sustainable circular economy, *J. Clean. Prod.* 365 (2022), <https://doi.org/10.1016/j.jclepro.2022.132674>.
- C.C. Seah, C.H. Tan, N.A. Arifin, R.S.R.M. Hafriz, A. Salmiaton, S. Nomanbhay, A. H. Shamsuddin, Co-pyrolysis of biomass and plastic: Circularity of wastes and comprehensive review of synergistic mechanism, *Results Eng.* 17 (2023), <https://doi.org/10.1016/j.rineng.2023.100989>.
- H. Thunman, T. Berdugo Vilches, M. Seemann, J. Maric, I.C. Vela, S. Pissot, H.N. T. Nguyen, Circular use of plastics-transformation of existing petrochemical clusters into thermochemical recycling plants with 100% plastics recovery, *Sustain. Mater. Technol.* 22 (2019), <https://doi.org/10.1016/j.susmat.2019.e00124>.
- W. Kaminsky, Chemical recycling of plastics by fluidized bed pyrolysis, *Fuel Commun.* 8 (2021), <https://doi.org/10.1016/j.fucom.2021.100023>.
- V. Wilk, H. Hofbauer, Conversion of mixed plastic wastes in a dual fluidized bed steam gasifier, *Fuel*. 107 (2013), <https://doi.org/10.1016/j.fuel.2013.01.068>.
- R. Forero-Franco, I. Cañete-Vela, T. Berdugo-Vilches, J. González-Arias, J. Maric, H. Thunman, M. Seemann, Correlations between product distribution and feedstock composition in thermal cracking processes for mixed plastic waste, *Fuel*. 341 (2023), <https://doi.org/10.1016/j.fuel.2023.127660>.
- C. Mandviwala, J. González-Arias, T. Berdugo Vilches, M. Seemann, H. Thunman, Comparing bed materials for fluidized bed steam cracking of high-density polyethylene: Olivine, bauxite, silica-sand, and feldspar, *J. Anal. Appl. Pyrolysis* 173 (2023), <https://doi.org/10.1016/j.jaap.2023.106049>.
- S.H. Jung, M.H. Cho, B.S. Kang, J.S. Kim, Pyrolysis of a fraction of waste polypropylene and polyethylene for the recovery of BTX aromatics using a fluidized bed reactor, *Fuel Process. Technol.* 91 (2010), <https://doi.org/10.1016/j.fuproc.2009.10.009>.
- S. Li, I. Cañete Vela, M. Järvinen, M. Seemann, Polyethylene terephthalate (PET) recycling via steam gasification – the effect of operating conditions on gas and tar composition, *Waste Manag.* 130 (2021), <https://doi.org/10.1016/j.wasman.2021.05.023>.
- H.L. Zhu, Y.S. Zhang, M. Materazzi, G. Aranda, D.J.L. Brett, P.R. Shearing, G. Manos, Co-gasification of beech-wood and polyethylene in a fluidized-bed reactor, *Fuel Process. Technol.* 190 (2019), <https://doi.org/10.1016/j.fuproc.2019.03.010>.
- J. González-Arias, T. Berdugo-Vilches, C. Mandviwala, I. Cañete-Vela, M. Seemann, H. Thunman, Effect of biomass ash on preventing aromatization of olefinic cracking products in dual fluidized bed systems, *Fuel*. 338 (2023), <https://doi.org/10.1016/j.fuel.2022.127256>.
- B.J. Milne, L.A. Behie, F. Berruti, Recycling of waste plastics by ultrapyrolysis using an internally circulating fluidized bed reactor, *J. Anal. Appl. Pyrolysis* 51 (1999), [https://doi.org/10.1016/S0165-2370\(99\)00014-5](https://doi.org/10.1016/S0165-2370(99)00014-5).
- R. Forero-Franco, T. Berdugo-Vilches, C. Mandviwala, M. Seemann, H. Thunman, Developing a parametric system model to describe the product distribution of steam pyrolysis in a dual fluidized bed, *Fuel*. 348 (2023), <https://doi.org/10.1016/j.fuel.2023.128518>.

- [19] M.L. Mastellone, F. Perugini, M. Ponte, U. Arena, Fluidized bed pyrolysis of a recycled polyethylene, *Polym. Degrad. Stab.* 76 (2002), [https://doi.org/10.1016/S0141-3910\(02\)00052-6](https://doi.org/10.1016/S0141-3910(02)00052-6).
- [20] S.P. Pyl, C.M. Schietekat, K.M. Van Geem, M.F. Reyniers, J. Vercammen, J. Beens, G.B. Marin, Rapeseed oil methyl ester pyrolysis: On-line product analysis using comprehensive two-dimensional gas chromatography, *J. Chromatogr. A* 1218 (2011), <https://doi.org/10.1016/j.chroma.2010.12.109>.
- [21] R. De Bruycker, I. Amghizar, F.H. Vermeire, T. Nyman, M. Hakola, K.M. Van Geem, Steam cracking of bio-derived normal and branched alkanes: Influence of branching on product distribution and formation of aromatics, *J. Anal. Appl. Pyrolysis* 122 (2016), <https://doi.org/10.1016/j.jaap.2016.10.017>.
- [22] H.E. Toraman, T. Dijkmans, M.R. Djokic, K.M. Van Geem, G.B. Marin, Detailed compositional characterization of plastic waste pyrolysis oil by comprehensive two-dimensional gas-chromatography coupled to multiple detectors, *J. Chromatogr. A* 1359 (2014), <https://doi.org/10.1016/j.chroma.2014.07.017>.
- [23] M.S. Abbas-Abadi, M. Kusenberg, A. Zayoud, M. Roosen, F. Vermeire, S. Madanikashani, M. Kuzmanović, B. Parvizi, U. Kresovic, S. De Meester, K.M. Van Geem, Thermal pyrolysis of waste versus virgin polyolefin feedstocks: the role of pressure, temperature and waste composition, *Waste Manag.* 165 (2023), <https://doi.org/10.1016/j.wasman.2023.04.029>.
- [24] L. Negahdar, A. Gonzalez-Quiroga, D. Otyuskaya, H.E. Toraman, L. Liu, J.T.B. H. Jastrzebski, K.M. Van Geem, G.B. Marin, J.W. Thybaut, B.M. Weckhuysen, Characterization and comparison of fast pyrolysis bio-oils from pinewood, rapeseed cake, and wheat straw using ¹³C NMR and comprehensive GC × GC, *ACS Sustain. Chem. Eng.* 4 (2016), <https://doi.org/10.1021/acssuschemeng.6b01329>.
- [25] M.N. Dunkle, P. Pijcke, W.L. Winniford, M. Ruitenbeek, G. Bellos, Method development and evaluation of pyrolysis oils from mixed waste plastic by GC-VUV, *J. Chromatogr. A* 1637 (2021), <https://doi.org/10.1016/j.chroma.2020.461837>.
- [26] K.A. Schug, I. Sawicki, D.D. Carlton, H. Fan, H.M. McNair, J.P. Nimmo, P. Kroll, J. Smuts, P. Walsh, D. Harrison, Vacuum ultraviolet detector for gas chromatography, *Anal. Chem.* 86 (2014) 8329–8335, <https://doi.org/10.1021/ac5018343>.
- [27] E. Lazzari, M. Piparo, C. Mase, L. Levacher, P.H. Stefanuto, G. Purcaro, J.F. Focant, P. Giusti, Chemical elucidation of recycled plastic pyrolysis oils by means of GC×GC-PI-TOF-MS and GC-VUV, *J. Anal. Appl. Pyrolysis* 176 (2023), <https://doi.org/10.1016/j.jaap.2023.106224>.
- [28] M. Israelsson, M. Seemann, H. Thunman, Assessment of the solid-phase adsorption method for sampling biomass-derived tar in industrial environments, *Energy Fuel* 27 (2013), <https://doi.org/10.1021/ef401893j>.
- [29] G. Elordi, M. Olazar, G. Lopez, M. Artetxe, J. Bilbao, Product yields and compositions in the continuous pyrolysis of high-density polyethylene in a conical spouted bed reactor, *Ind. Eng. Chem. Res.* 50 (2011), <https://doi.org/10.1021/ie200186m>.
- [30] A. Larsson, M. Seemann, D. Neves, H. Thunman, Evaluation of performance of industrial-scale dual fluidized bed gasifiers using the chalmers 2-4-MWth gasifier, *Energy Fuel* 27 (2013), <https://doi.org/10.1021/ef400981j>.
- [31] M. Artetxe, G. Lopez, G. Elordi, M. Amutio, J. Bilbao, M. Olazar, Production of light olefins from polyethylene in a two-step process: Pyrolysis in a conical spouted bed and downstream high-temperature thermal cracking, *Ind. Eng. Chem. Res.* 51 (2012), <https://doi.org/10.1021/ie300178e>.
- [32] J.P.A. Neef, H.A.M. Knoef, U. Zielke, K. Sjoström, P. Hasler, P.A. Simell, M. A. Dorrington, C. Greil, Tar protocol. Development of a standard method for the measurement of organic contaminants (tar) in biomass producer gases, in: *Proceedings of the 1st World Conference on Biomass for Energy and Industry, Sevilla, Spain, 2000, 2000*.
- [33] M. Neubert, S. Reil, M. Wolff, D. Pöcher, H. Stork, C. Ultsch, M. Meiler, J. Messer, L. Kinzler, M. Dillig, S. Beer, J. Karl, Experimental comparison of solid phase adsorption (SPA), activated carbon test tubes and tar protocol (DIN CEN/TS 15439) for tar analysis of biomass derived syngas, *Biomass Bioenergy* 105 (2017), <https://doi.org/10.1016/j.biombioe.2017.08.006>.
- [34] D.S. Achilias, C. Roupakias, P. Megalokonomos, A.A. Lappas, V. Antonakou, Chemical recycling of plastic wastes made from polyethylene (LDPE and HDPE) and polypropylene (PP), *J. Hazard. Mater.* 149 (2007), <https://doi.org/10.1016/j.jhazmat.2007.06.076>.
- [35] C. Mandviwala, T. Vilches Berdugo, M. Seemann, J. González-Arias, H. Thunman, Unraveling the hydrocracking capabilities of fluidized bed systems operated with natural ores as bed materials, *J. Anal. Appl. Pyrolysis* 166 (2022), <https://doi.org/10.1016/j.jaap.2022.105603>.
- [36] I. Cañete Vela, J. Maric, J. González-Arias, M. Seemann, Feedstock recycling of cable plastic residue via steam cracking on an industrial-scale fluidized bed, *Fuel* 355 (2024), <https://doi.org/10.1016/j.fuel.2023.129518>.
- [37] A. Horvat, M. Kwapinska, N. Abdel Karim Aramouni, J.J. Leahy, Solid phase adsorption method for tar sampling – how post sampling treatment affects tar yields and volatile tar compounds? *Fuel* 291 (2021) <https://doi.org/10.1016/j.fuel.2020.120059>.
- [38] M. Israelsson, A. Larsson, H. Thunman, Online measurement of elemental yields, oxygen transport, condensable compounds, and heating values in gasification systems, *Energy Fuel* 28 (2014), <https://doi.org/10.1021/ef501433n>.