



Roadmaps for heating and cooling system transitions seen through uncertainty and sensitivity analysis

Downloaded from: <https://research.chalmers.se>, 2026-04-04 01:17 UTC

Citation for the original published paper (version of record):

Zhang, Y., Johansson, P., Sasic Kalagasidis, A. (2023). Roadmaps for heating and cooling system transitions seen through uncertainty and sensitivity analysis. *Energy Conversion and Management*, 292. <http://dx.doi.org/10.1016/j.enconman.2023.117422>

N.B. When citing this work, cite the original published paper.

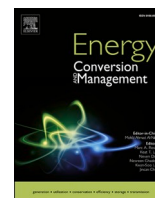

Roadmaps for heating and cooling system transitions seen through uncertainty and sensitivity analysis

Yichi Zhang^{*}, Pär Johansson, Angela Sasic Kalagasidis

Department of Architecture and Civil Engineering, Division of Building Technology, Chalmers University of Technology, Gothenburg 412 96, Sweden

ARTICLE INFO

Keywords:

District heating and cooling
Uncertainty analysis
Sensitivity analysis
Multiple objectives
Bi-directional system

ABSTRACT

Future district heating systems should enable efficient and economic energy supply, which can be achieved by lowering the system temperatures and boosting it at demand-side. Current solutions include the ultra-low-temperature district heating (ULTDH) and fifth generation district heating and cooling (5GDHC) systems. The transition towards these systems is subject to multiple future uncertainties such as the energy price, investment cost, and demand changes, which were missing in previous works. To investigate the effects of these uncertainties on conclusions brought by established design roadmaps for future DHCs, a five-step framework, which combines the energy system optimization with stochastic simulations, uncertainty analysis and sensitivity assessment, is developed in this study. The framework is applied on a hypothetical 0.25 km² square district with varying uncertain parameters. Based on stochastic cases, the index named cost-saving probability (CSP) is utilized to reflect the potential of being economic attractive when comparing the energy systems. For the transition towards the ULTDHC, 5GDHC, and individual systems, the most sensitive factors for the CSP are the area demand density, overlapping heating and cooling demand, and linear demand density, respectively. The investment in thermal energy storage (TES) becomes important only when the integration of a larger share of renewable energy is targeted. A roadmap summarizing the promoting and hindering factors for the system transition is provided, pointing out the future focus area for DHC design. The results from the sensitivity analysis also revealed the limited role of TES in integrating variable renewable energy in high-efficiency DHC systems.

1. Introduction

1.1. Background

Heating and cooling for buildings represent over 20% of the final energy use within the European Union, with only 23% of this energy based on renewable energy sources [1]. To achieve the greenhouse gas emission target and to reduce the reliance on fossil fuels, a set of proposals and strategies were recommended by the European Commission [2]. Although there is no universal answer to the sustainable challenges, the low-temperature district heating, or sometimes referred to as the fourth-generation district heating (4GDH), has been recommended as a robust solution [3].

Driven by the energy efficient building stock and the integration of the energy sectors, the 4GDH enables lower grid losses, the integration potential of waste heat and renewable sources, and higher energy supply efficiency, compared to the current DH system with 80 °C [4]. A recent

guidebook has summarized the economic benefits, practical implementations, obstacles, and challenges of 4GDH, based on over 100 initiatives and cases [5]. With several early adopters, the 4GDH is proved as a technology-ready option, while the hurdles to start the transition are old habits and missing link between stakeholders [5].

To further utilize the waste heat that has temperatures close to the ambient, the fifth-generation district heating and cooling (5GDHC), or sometimes referred to as *Bi-directional Network* [6,7] or *Cold District Heating Network* [8], has been studied in recent years [9]. The key definition of such system is that the distribution network is operated at very low temperature close to the ambient (around 10 °C to 30 °C), serving as both heat source and sink for the heating and cooling demand. The required temperatures at demand-side are controlled via end-use water-source heat pumps (HPs) and chillers. Thereby, the system is capable of supplying the heating and cooling demand at the same time, with minimal transmission thermal losses from the network [10]. As the cooling demand in European buildings is believed to grow rapidly in the future due to global warming and building renovation projects [11],

^{*} Corresponding author at: Department of Architecture and Civil Engineering, Division of Building Technology, Chalmers University of Technology, 412 96 Gothenburg, Sweden.

E-mail address: yichi@chalmers.se (Y. Zhang).

<https://doi.org/10.1016/j.enconman.2023.117422>

Received 5 June 2023; Received in revised form 12 July 2023; Accepted 14 July 2023

Available online 18 July 2023

0196-8904/© 2023 The Authors. Published by Elsevier Ltd. This is an open access article under the CC BY license (<http://creativecommons.org/licenses/by/4.0/>).

Nomenclature

4GDHC	Fourth generation district heating and cooling
5GDHC	Fifth generation district heating and cooling
CAPEX	Capital expenditure
COP	Coefficient of performance
DHC	District heating and cooling
DHW	Domestic hot water
HP	Heat pump
LCOE	Levelized cost of energy
MC	Monte Carlo
OBJ	Objective
O&M	Operation and maintenance
OPEX	Operational expenditure
PR	Plot ratio
PV	Photovoltaic
TES	Thermal energy storage
ULTDHC	Ultra-low temperature district heating and cooling

Table 1

An overview of the recent studies on the 5GDHC system with focus on the system comparison and scenarios that influence the performance.

Reference system for comparison	Scenarios				Ref
	Demand	Price	Efficiency	Objective	
Gas-fired DH, individual HP and chiller			✓	Economy	[13]
Individual HP and chiller	✓			Economy	[20]
Individual HP and chiller				Economy	[6]
5GDHC alone				Self-sufficiency	[21]
Gas-fired DH			✓	Economy	[22]
5GDHC alone	✓			Self-sufficiency	[23]
4GDHC, geothermal grid				Economy	[14]
4GDHC, ULTDHC	✓		✓	Economy	[19]
4GDHC, ULTDHC	✓	✓		Economy	[17]

such recovery of waste heat from cooling process in the 5GDHC system is promising. Accordingly, there is a growing number of research works on the 5GDHC, as reported in the statistical survey of 40 operating systems [9] and a recent review paper [12]. Previous studies have examined the exergy efficiency [13], environmental impact [14], economic feasibility [6], and field operation management [15] of the 5GDHC.

Despite the growing interest on the 5GDHC system, the reported field implementations present large variability, due to the different applied scenarios [9,12,16]. In fact, the optimal choice on the technology transition is influenced by factors from various aspects such as the demand profiles, equipment efficiencies, economic parameters, business models, and social-political issues. As indicated in a previous work [17], the future challenges and changes from the supply side and demand side are also playing crucial roles on the system. The recent studies on the 5GDHC system that have compared the system performance under different scenarios are summarized in Table 1. It is seen that most of the research works were placed within limited situations, leaving the general applicability of the 5GDHC system still unknown. For example, studies on the optimal design of the system [6,18] were based on cases that already have balanced heating and cooling demand, which are favorable scenarios for the 5GDHC system. Indeed, Wirtz et al. [7] have identified the key performance indicator (KPI) of demand overlap coefficient (DOC) to judge the feasibility of 5GDHC according to demand

profiles. In terms of energy prices, a higher electricity price would make the 5GDHC system more economically attractive since the larger operational cost is saved by the high-efficiency equipment, as proved in a previous study by the authors [17]. However, as a relatively new technology, the uncertainties associated with investment costs for the 5GDHC system in the future are not considered in previous works. Since that a large part of the overall system cost is from the initial investment [8], the results under uncertainties remains unclear. Moreover, the influence of system efficiency was investigated in previous works with several typical temperature levels representing the different heating and cooling sources [13,19]. However, the efficiency changes in the local booster HPs and chillers were not considered. In summary, the transition towards 5GDHC system is subject to multiple uncertainties, and a comprehensive analysis of these factors is still lacking. The quantitative study on the significances of uncertainties is needed to guide the future applications of this new technology.

Unlike the 5GDHC system, there are better understandings about the uncertainties and sensitivities for the ultra-low temperature district heating (ULTDH) system [24–27]. This system has enough supply water temperature of around 40 °C for space heating demand directly, but relies on booster HPs in the demand side to raise the water temperature to the required hygienic level [28]. The cooling sector is the same as the traditional DC system, which is separate from the heating sector. Thereby, this system is also regarded as an intermediate step between 4GDH and 5GDH [19]. The influences of different investment costs, interest rates [24], equipment efficiencies [25], and demand profiles [27] on the ULTDH system were investigated. Despite the interests on the ULTDH system alone, a major research gap is that the optimal choice between ULTDH and 5GDHC systems is seldom known, as is further elaborated in the subsequent paragraph.

To identify the economic and technical feasibility, the 5GDHC system is commonly compared with several reference system options representing the state-of-art technologies in previous papers, as summarized in Table 1. However, individual systems and traditional gas-fired DH systems were mostly used for comparison, which could not reflect the on-going trend towards 4GDH. Indeed, as pointed out in a recent perspective paper [10], the 5GDHC can be regarded as a parallel technology coexist with other 4GDH technologies, but not a sequential evolution. Yet, there is no given answer on the optimal choice between 4GDH and 5GDHC, and the applicability of two systems shall be further investigated. The overall cost of the 5GDHC system is compared with 4GDH and ULTDHC system in previous papers [17,19], but the deterministic scenarios and changes, as indicated earlier, cannot reflect the uncertainties in the future. According to Refs [19,29], such comparison is challenging since the system cost is sensitive to price changes.

From another perspective, the comparisons of DHC systems were mostly placed under the economic objective of minimal cost, while limited works [21,23] have considered the self-sufficiency as objective. With growing requirement on achieving the carbon emission target [2], the minimal system cost cannot be regarded as the sole objective for designing the DHC system. Environmental targets such as limited carbon emissions from the system and certain renewable energy utilizations shall also be considered. Despite the possibility of having a higher overall system cost from current perspective, such target could be motivated with future carbon taxes or future cost for climate change mitigation actions from society's perspective. With multiple objectives, the comparisons between 4GDH and 5GDHC require further notice.

It is important to consider the possibilities of all parameters to acquire more robust and reliable evidence for the system application. This calls the uncertainty analysis, which describes the probability distributions of desired system performance with uncertain parameters [30]. Moreover, with the sensitivity analysis method, the specific influences from different uncertain factors and their importance can be quantified and ranked [31]. Such analysis methods have been widely applied in distributed energy systems to find the optimal design [32–34], which provide strong knowledge background for this research work. In the

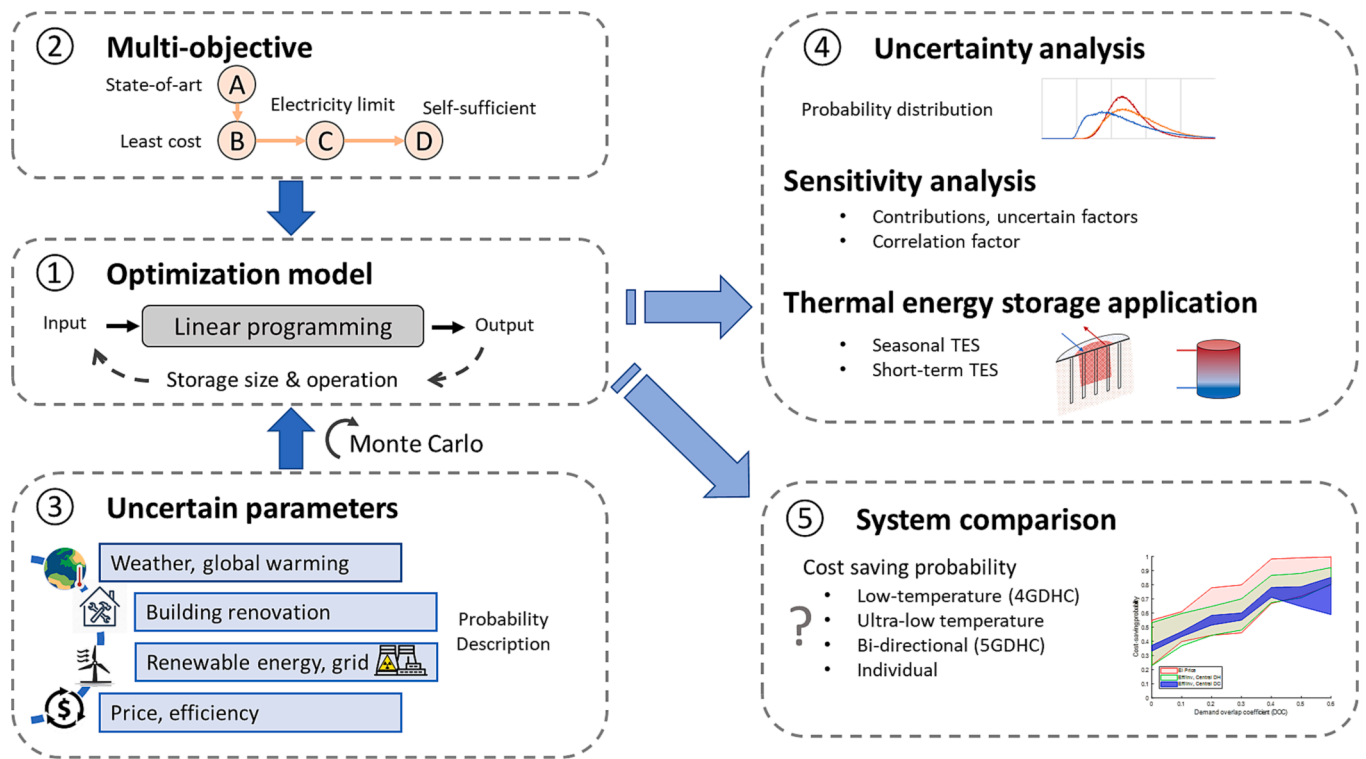

Fig. 1. General methodology framework for uncertainty and sensitivity analysis for the DHC systems.

DHC research area, the analysis methods were mostly applied in centralized DH systems, like the solar DH systems [35] and 4GDH systems [36]. These methods have not been applied in the 5GDHC system yet, leaving the performance uncertainties and the sensitivities of parameters unknown.

1.2. Contributions and paper organization

To close the gaps, the previous works on ULTDH and 5GDHC systems are based on deterministic scenarios, while the uncertainties of the two new technologies and the sensitivities of relevant parameters remain unclear. This paper aims to answer these questions by the following contributions:

- The development of a complete methodological framework with uncertainty analysis and sensitivity analysis, applied on the dynamic models of the ULTDH and 5GDHC systems. With the stochastic method, the model is capable of finding the optimal energy system performance fulfilling the design objective under wide ranges of uncertainties.
- The consideration of parameters from various aspects that cover the major uncertainties in DHC system applications, including the demand profile, energy price, investment cost, equipment efficiency, renewable energy production, and design objective.
- The comparison of 4GDHC, ULTDHC, 5GDHC, and individual systems in terms of economic and environmental performance. The attractiveness of energy system options is quantified and the most significant factors for the system design were revealed.
- The investigation of several energy system objectives for future sustainable development. The different system choices and the sensitive factors under these objectives were evaluated.

More specifically, with the aforementioned contributions, the main novelty of this paper is the answer to the question: which factors lead to the applications of ULTDH and 5GDHC systems, respectively?

This paper is organized as follows: Section 2 introduces the

investigated systems and the numerical models. Section 3 describes the studied uncertain parameters for energy system applications. Section 4 explains the analysis methods for uncertainties, sensitivities, and the KPIs. The results and discussions are presented in Section 5 and 6, respectively.

2. Methodology

The whole methodology framework of this study consists of five major steps, as presented in Fig. 1. Step 1 includes the dynamic thermal models for the DHC systems and the linear optimization problem to find the optimal system design and operation. Step 2 defines four objectives (OBJs) for designing the DHC systems, based on considerations from economic, environmental, and societal aspects. As a major contribution of this paper, the uncertainty characteristics of the input parameters for the DHC systems are identified in Step 3. Stochastic combinations of uncertain parameters were input into the optimization model defined in Step 1. Based on these steps, Monte Carlo (MC) simulations are conducted in Step 4 to find the general distributions of DHC performance, as well as the sensitivities of uncertain input parameters. In Step 5, the DHC systems are compared on a variety of stochastic cases. The most significant factors for the system transitions are identified, with the indicator called cost-saving probability.

2.1. System description

To evaluate the future transitions of heating and cooling systems, four typical system configurations were modelled and compared in this study. The general design principles are introduced in this section, while the design details such as equipment efficiencies and costs are explained in Section 3 as uncertain parameters.

- 4GDHC: Representation of the low-temperature network [5]. The heating is supplied by the central HP with temperatures of 65/35 °C for the supply and return lines, respectively. Radiators are commonly used to release heat to indoor environment. The cooling demand is

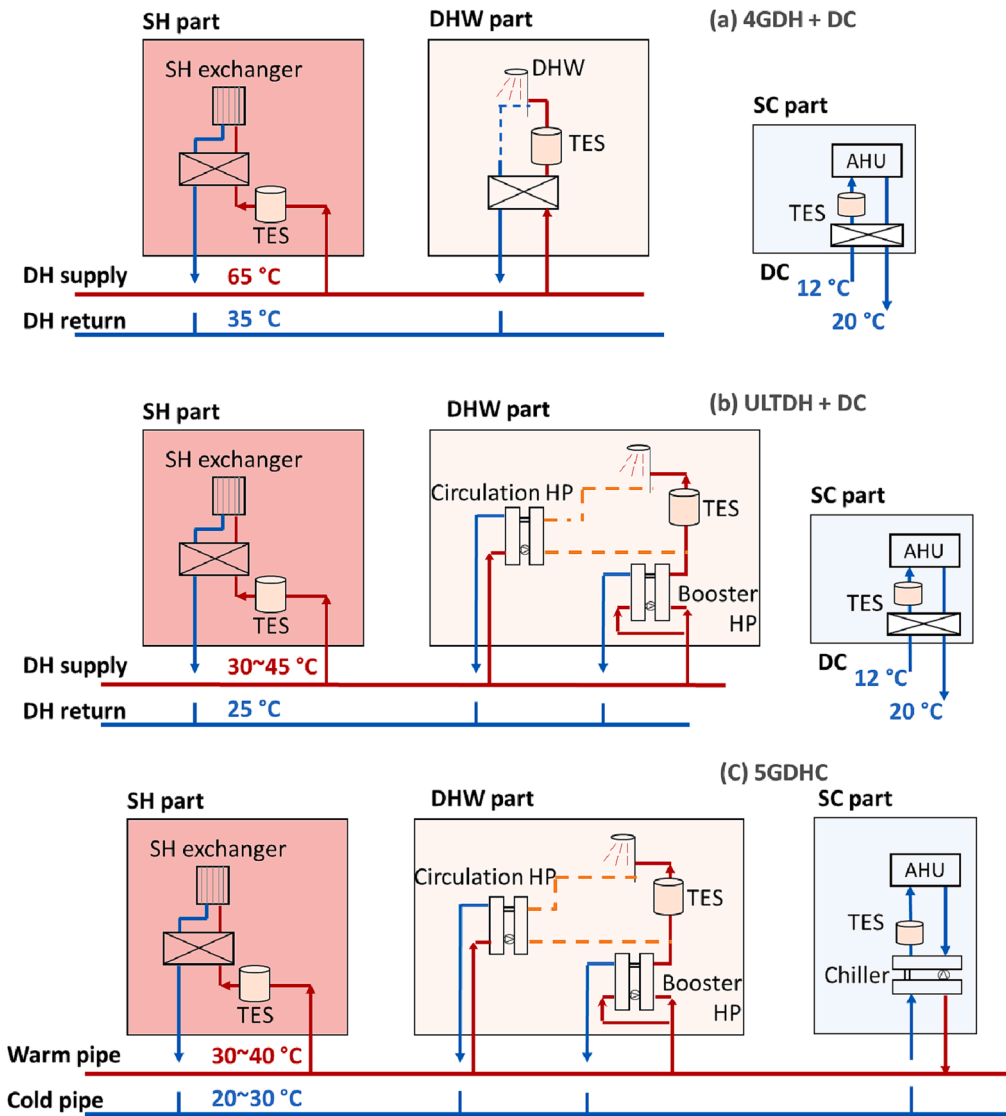

Fig. 2. Typical structures of substations in the 4GDHC, ULTDHC, and 5GDHC systems.

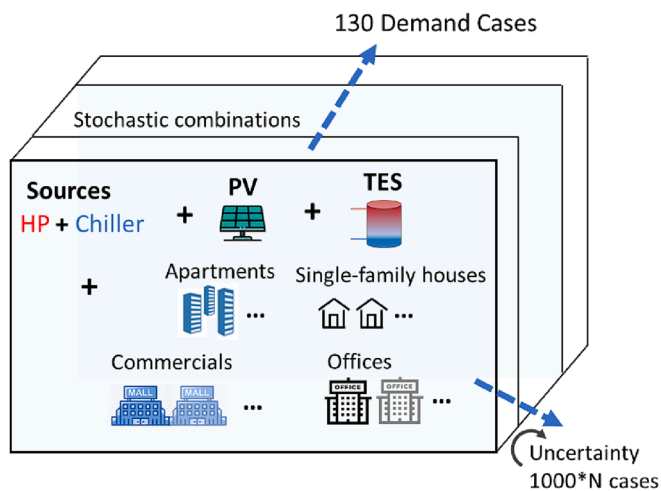

Fig. 3. Illustration of the demand cases based on stochastic combinations of buildings. N represents the number of uncertain parameters.

prepared by the city central DC system with cold water temperature of 12 °C, according to the field investigations [37].

- ULTDHC: Combination of ULTDH and DC system. The supply water temperature from the central HP is reduced to around 30 °C to 45 °C, which can fulfill the space heating demand in buildings directly, e.g. without conversions in local substations [38]. In order to achieve so, traditional radiators inside buildings shall be upgraded with larger area or replaced with floor heating pipes. To raise the water temperature for domestic hot water (DHW) demand, water-source booster HPs are installed in the substations [28]. During low DHW demand period, the water-source circulation HP is activated to cover the circulation heat losses while maintaining required return temperature by the evaporator. The cooling is supplied by the central DC system, which is the same as that in the 4GDHC system.
- 5GDHC: Bi-directional looped network with heating and cooling exchange between buildings using warm and cold pipes. The warm pipe temperature is maintained at around 30 °C to 40 °C while the cold pipe temperature is around 20 °C to 30 °C. Besides the booster HPs, water-source chillers are also installed in the demand-side to prepare the cold water for cooling demand. The heated water from the condenser is in-turn discharged into the warm pipe, which can be used for the heating demand. External sources, including the central HP and compression chiller, are operated to maintain the network at

Table 2

Descriptions of four objectives investigated in this study for designing the DHC system.

Objective	Description	Measure
A	Minimal overall system cost	Heating and cooling systems
B	Use of local PV at the most economical way	Optimized PV capacity
C	Import electricity limit: 0.1 kWh _e /1 kWh _{demand}	Optimized PV + seasonal TES
D	Import electricity limit: 0.05 kWh _e /1 kWh _{demand}	Optimized PV + seasonal TES

desired temperatures when the heating and cooling demand cannot be internally balanced.

- Individual: De-centralized building-level solution. Air-source HPs with two levels of supply water temperatures are responsible for the space-heating demand and DHW demand separately. The cooling is supplied by air-source chillers. Compared to central solutions, the individual equipment has a wider range of energy efficiencies and investments, which are considered as uncertain parameters in [Section 3](#).

The typical structures of substations and design temperatures in the 4GDHC, ULTDHC and 5GDHC systems, are presented in [Fig. 2](#). For the individual systems, the air-source HPs and chillers are directly connected to the indoor part and the structure is neglected in [Fig. 2](#).

This study investigates the uncertain demands and cases by using stochastic combinations of different buildings within a hypothetical district. Illustration of the methodology is shown in [Fig. 3](#), while detailed parameters about buildings and equipment are explained in [Section 3](#). Residential, commercial, and office buildings are stochastically combined to formulate several identical demand cases. Based on the demand profiles, the entire heating and cooling system including sources, networks, thermal energy storage (TES) units, and auxiliary equipment are correspondingly designed. The sizing of components and the operation schemes are optimized considering different objectives on life-cycle cost and integration of local renewable electricity, as further explained in [Section 2.2](#). Unlike previous works that deal with pre-defined equipment, this study considers a range of uncertain parameters about equipment efficiencies, costs, and electricity prices. The Monte-Carlo simulations from [Section 4.1](#) are conducted to generate thousands of stochastic cases based on combinations of these uncertain parameters. For each case, an optimization problem is solved to find the component sizes and operation schedules that fulfill different objectives. Meanwhile, four typical system configurations as illustrated in [Fig. 2](#) are also compared to identify the competitiveness of different solutions under uncertainties. Finally, the aggregated results from stochastic cases are analyzed to reveal the sensitivities of uncertain parameters.

In total, 130 demand cases were considered in this study and more detailed information about these cases is provided in [Section 3.1](#). The models for the DHC systems are based on the linearized system developed in previous studies by the authors [[17,39](#)]. The hypothetical district is set in the Gothenburg region, Sweden.

To simplify the analysis process, only one hypothetical central heat source and one cooling source is considered, which is an electric-driven HP and a compression chiller. The complex realistic operating conditions are modelled by alternating coefficients of performance (COPs) of the equipment within a wide probabilistic range, as provided in [Section 3.2](#). In order to reduce the simulation and optimization burdens, the practical connections between the substations and end-use buildings are represented by simple energy exchange without resistance or time delay. Thermal losses and energy consumptions from additional equipment such as booster HPs are calculated according to the system configurations and parameters from [Section 3.2](#).

The complex DHC networks are represented by two thermal storage

capacities for the supply and return lines, respectively. The hydraulic conditions such as the pressure distributions over the network are not considered in this study to linearize the whole system model and simplify the follow-up optimization process. The temperature evolution $T_{network}$ for each pipe is written in [Eq. \(1\)](#).

$$C_{network}(T_{network,\tau+1} - T_{network,\tau}) = (P_{inflow} - P_{outflow}) \bullet \Delta t \quad (1)$$

where τ is the time step. $C_{network}$ is the heat capacity of the water inside specific pipe. P_{inflow} and $P_{outflow}$ are inflow and outflow powers, which include the heat losses and the heat exchanged on the demand-side. For transmission heat losses along the pipe length, a heat loss rate of 0.1 W/(m·K) is used.

Based on investigations of several district heating systems in Sweden, an empirical equation to describe the length of the network L_{pipe} within a specific area is established [[40](#)], written as:

$$\frac{A_L}{L_{pipe}} = 61.8 \bullet PR^{-0.15} \quad (2)$$

where A_L is the total land area (m²). PR is the plot ratio, defined as a fraction between the building floor area and occupied land area, to express the building density within a city area. High plot ratio implies large floor area and, thereby, long distribution networks of DHC systems.

Similar to modelling procedures in the previous works of the authors [[17,39](#)], the demand for space heating and cooling is calculated by a two-node capacities model with five resistances [[41](#)]. Domestic hot water draw-off profiles are generated by a stochastic modelling tool called *DHWcalc* [[42](#)]. The material properties and air exchanges rates are also uncertain parameters for the buildings, as explained in [Section 3.1](#).

This study also considered five types of water tanks as common TES units in DHC systems, including local building-level water tank for heating and cooling, central water tank for heating and cooling, and water pit for seasonal TES. As shown in [Fig. 2](#), the building-level tanks are installed inside the substations and are mostly used for peak power reduction. The central water tanks have lower investment per volume and are more used to interact with the supply side sources like the variable electricity prices and renewable energy [[43](#)]. In the 5GDHC system, there is only one central tank that operates between the warm and cold pipes. The potential benefit of internally balanced heating and cooling demands is, thereby, enabled. For the individual systems, the central water tanks are not considered. The general models for the water tanks are given in [Appendix A.1](#). Similar to other equipment in DHC systems, the sizes of TES units and their hourly operation schemes are optimized for different objectives. The optimization is conducted for every stochastic case and the resulting applications of TES are summarized in [Section 5.4](#).

Due to the large seasonal difference between the heating demand in winter and the PV power supply in summer, the seasonal TES is considered as an option to further increase the renewable energy integration and to achieve the decarbonization of the DHC system. The pit TES is chosen in this study considering its reliability and ability to supply the heating demand directly. The available PV power in summer is used to drive the HPs to charge the pit TES. In winter, the hot water from the pit TES is discharged to cover the heating demand.

2.2. Multi-objective optimization

Four objectives for designing the DHC systems are formulated, representing different considerations from economic and environmental aspects. An overview of the objectives is presented in [Table 2](#). The objective A reflects the viewpoint to build a functional energy system at least cost, which is also the most considered objective in previous research works. In this regard, the PV and seasonal TES are not considered for objective A due to the uncertainties associated with investment and control. To achieve the target, the main objective function

Table 3
General distributions of uncertain parameters.

Category	Distribution
Demand	Discrete, 130 cases
Equipment efficiency	Uniform, 8 parameters
Equipment cost	Uniform, 13 parameters
Electricity price	Discrete, 45 cases

Table 4
The case buildings and the ranges of heating and cooling demand.

Buildings	Area (m ²)	Demand ranges (kWh/m ²)		
		SH	DHW	SC
Multi-family house	2,000	32 ~ 158	15	0
Single-family house	200	80 ~ 150	18	0
Office	3,000	48 ~ 79	3	10 ~ 18
Commercial	5,000	46 ~ 73	2	15 ~ 31

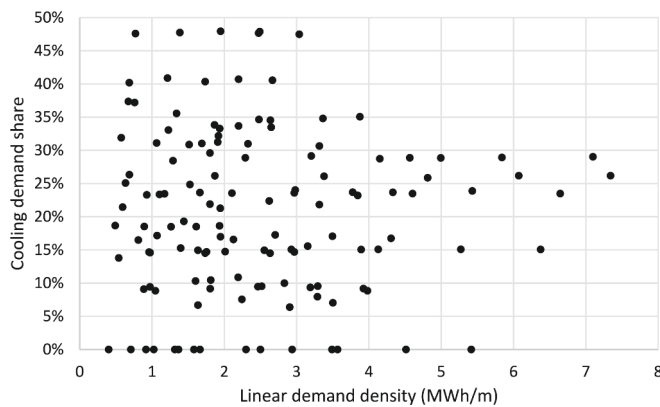

Fig. 4. Linear demand density and cooling demand share of the selected demand cases.

for the optimization of the DHC systems is written in Eq. (3).

$$\text{min cost} = \text{CAPEX} + \text{OPEX} \quad (3)$$

where CAPEX is the annualized capital expenditure for the whole system including the central and local sources, network, substation, and TES units. The costs associated with buildings and indoor heating/cooling terminals are not considered because they belong to the construction and housing aspect. An interest rate of 5% is used to calculate annualized investment.

The operational expenditure (OPEX) refers to the electricity bills since the heating and cooling sources are all electricity driven. The variable electricity price is also an uncertain parameter and generated by modelling the whole Swedish electricity network under different scenarios, provided in Section 3.3.

The decision variables for the problem are the operation actions and design capacities. The former includes the charging and discharging operations of the TES units to utilize the variable electricity prices, reduce peak power cost, and increase the use of renewable energy sources. The latter refers to the capacities for the DHC sources and the TES units. The minimal time step is set as one hour in accordance with the demand profile. The whole model is a mixed-integer linear problem, developed and performed in MATLAB.

The growing trend on utilizing renewable energy to decarbonize the whole district is reflected in objectives B to D. The rooftop PV panel is investigated considering its technological readiness, modelled with the Photovoltaic Geographical Information System-interactive tool [44]. For objective B, the local PV panels are installed and used in the most economical way, representing the common perspective for business

investment. Therefore, the decision of PV capacity is included in the optimization problem. As with other equipment, the investment cost for PV is also an uncertain parameter. It shall be noted that there are other sources of renewable energy like bioenergy or geothermal energy that can be used in 5GDHC. However, the availability of these resources is largely limited by geographical conditions and they are not considered in this study.

To reflect stricter targets towards the integration of renewable energy, the objectives C and D, which have specific limits on the imported electricity from the grid, are also considered. As shown in Table 2, the objective C is an intermediate step in terms of electricity usage while the objective D limits the imported electricity to only 5% of the total heating and cooling demand. Such limit also expresses the self-sufficiency of a district by renewable energy, as there are growing interest on energy autonomy and positive energy district [45]. Meanwhile, for an electrified DHC system, the operational carbon emission comes from the grid electricity. Thereby, the objectives C and D also reflect the targets for carbon emission reduction. To further reduce the imported electricity and to achieve these two objectives, the seasonal pit TES is applied. Due to a relatively large investment associated with the pit TES, its size is strictly optimized considering the least cost objective function and the electricity limit.

3. Uncertainty characterization

The uncertainties in space heating and cooling demands, equipment efficiencies, equipment costs, and energy prices are the four major types of uncertain parameters investigated in this study. A general overview of the distributions of these uncertain parameters is provided in Table 3.

3.1. Demand cases

Three types of buildings, including residential, office, and commercial, are investigated in this study. Thermal properties of materials and components in the building envelopes, as well as ventilation rates are uniformly distributed within the ranges that are representative for the buildings in Sweden, as presented in Appendix A.2. The weather conditions for year 2036, which has an annual average temperature closest to the 10-years average level in 2030 s, is chosen as the representative of the future weather. The forecast weather profiles are derived from the regional climate model RCA3, created by the Rossby Centre of the Swedish Meteorological and Hydrological Institute (SMHI).

The resulting heating and cooling demands for the case buildings are presented in Table 4. It can be seen that the buildings present wide ranges of energy performance, from high to low energy demands. Besides the four building types, the hypothetical process cooling demands for commercial users such as data centers and supermarket refrigerators are also considered within the district. The design cooling power ranges are assumed between 0 kW and 300 kW, and randomly sampled in the simulations. In most cases, as required by the specific users, the commercial and industrial processes have relatively stable schedule over time that is less influenced by outdoor temperature changes. Correspondingly, the resulting hourly cooling demand is also assumed stable throughout the whole year.

The studied hypothetical district is a square land with side length of 500 m. The planned building area density is decided by the plot ratio (PR), as is explained in Section 2.1. In total, five plot ratios, from 0.1 to 0.5 and step-increased by 0.1, are considered. According to the Swedish city planning, the selected PRs cover the rural sparse area (PR < 0.3) and dense inner city area (PR ≥ 0.5) [40]. The total building floor area within the district is decided and the cases buildings are stochastically combined to form more than 1,000 stochastic district-level demand cases. The combinations that have similar demand densities or cooling demand shares are omitted for further investigations, to reduce the calculation burden. Finally, 130 identical demand cases are selected, covering a wide range of demand densities, as shown in Fig. 4.

Table 5
Uncertain characteristics of COPs and investment costs for heating and cooling sources [48–52].

Technology	Description	COP		Investment (€/kW)		O&M
		Min	Max	Min	Max	
Central HP	In 4GDHC system, 65 °C forward temperature	3.1	5.2	300	600	2%
Central HP	In ULTDHC and 5GDHC systems	6.5	10.4	600	1,000	2%
Booster HP	In substations of ULTDHC and 5GDHC systems	4.9	6.8	600	1,600	3%
Central Chiller	Compression, in 4GDHC and ULTDHC systems	3.1	5.4	300	600	2%
Central Cooling	Back-up cooling source in 5GDHC system	3.5	15.3	100	600	2%
Local chiller	In substations of 5GDHC system	4.9	7.4	600	1,600	3%
Air-source HP	In individual building-level system	2.5	4.7	600	1,200	4%
Air-source chiller	In individual building-level system	3.1	5.1	800	1,400	4%

Table 6
Uncertain characteristics of investment costs for heat exchanger, TES units, and PV panels [48–52].

Technology	Description	Unit	Min	Max	O&M
Heat exchanger	In substations, including the auxiliary equipment	€/kW	50	150	1%
TES	Large central water tank (>100 m ³)	€/m ³	600	1,400	1%
	Demand-side building water tank (<1m ³)	€/m ³	2,000	4,000	1%
	Seasonal pit TES (>1,000 m ³)	€/m ³	10	50	2%
Rooftop PV	Residential and small district use	€/kW	600	1,400	2%

Table 7
The investigated future changes and uncertainties in the electrical system.

Name	Descriptions
Wind power	Production: 10% to 50% share in the annual national electricity demand Profile: past 10-years historical profiles. Full-load hours vary between 3,095 to 2,342
Nuclear power	Capacity: currently 8.5 GW to 0 GW
Fossil fuel	Price increase: 0% to 200%, compared to 2020 level
Feed-in price	Uniform distribution between 20 €/MWh to 120 €/MWh

3.2. Equipment efficiency and cost

To depict the characteristics of future changes, the probabilistic density function which explains the range of values and the probability of occurrence is commonly adopted [32–34]. According to Laplace’s original Principle of Insufficient reason, if there is no explicit reason to value one probability distribution over another, a uniform distribution shall be used [46]. Therefore, in this study, the uniform distribution is applied for the equipment efficiency and costs. A set of energy price profiles are created (see Table 7), following a discrete uniform distribution. The input price in the model is randomly sampled from the profiles.

In order to achieve the power-and-heat synergy, the heating and cooling sources investigated in this study are all electricity-driven. The variety of equipment efficiencies is expressed by the differences in the coefficients of performance (COPs), which are modeled with the

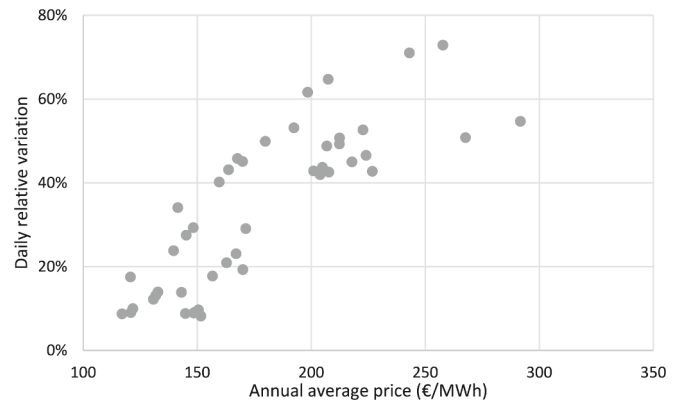

Fig. 5. Annual average values and daily relative variations of the 45 price profiles.

condensing temperature, evaporating temperature, and thermodynamic efficiency for the compressor η_c [47]. The temperatures are designed in accordance with the DHC systems, while the thermodynamic efficiency varies within a wide range based on data from technical reports [48] and experimental studies [49,50]. The resulting uncertain ranges of COPs for the heating and cooling sources are presented in Table 5.

For the central heating and cooling technologies, the supply water temperatures in different systems have generated different COPs. In the 5GDHC system, the central cooling is only used for maintaining the cold pipe temperature of around 20 °C to 30 °C, while the cold water in the demand-side is processed by end-user chillers (see Fig. 2). Therefore, the COP of central cooling is largely influenced by the availability of natural cooling sources, as expressed by the wide ranges of values in Table 5. If a natural cooling source is available, then only the pumping power is needed. Meanwhile, as a relatively new technology, the low-temperature HPs in the 5GDHC systems require better compressors and heat exchangers, making them more expensive than the HPs in 4GDH systems. As for individual HPs and chillers, due to the relatively small-scale of application for advanced equipment and control schemes, the COPs are generally smaller than that of the large central technologies.

In this work, the ranges of investment are derived from the forecast equipment prices in the future [48,51,52] considering market development and technical progress, as shown in Table 5 and Table 6. The uncertain changes in interest rates and lifespans are not considered. The annual operation and maintenance (O&M) cost is expressed as a fixed share of the initial investment. The annualized investment is calculated as input for the optimization problem in Eq. (3). Moreover, unlike the other equipment, the investment in network pipes is a defined value because a large part of it comes from construction and labor, which have relatively stable cost. The cost function of a pipe with diameter D_i is written in Eq. (4), approximated from manufacturers [53].

$$I_{pipe,i} = 130 + 1870 * D_i (\text{€/m}) \tag{4}$$

3.3. Renewable energy integration and electricity prices

It is commonly acknowledged that the future electrical network is associated with various changes and uncertainties [54]. As a result, the electricity market and price profiles are influenced. In this study, the ELIN-EPOD modelling package is used to generate variable price profiles [55]. The model has 50 price areas to represent the European transmission bottlenecks and can analyze the dynamic hourly energy flows. The price region of Sweden, which has hydropower and nuclear power for base load, is investigated in this work. More details about the applications of this modelling package for analyzing the future prices can be found in [17,56].

In this work, the most significant factors for the electricity prices, as

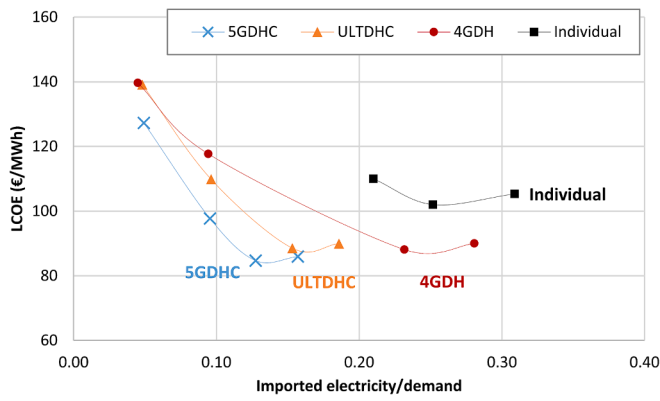

Fig. 6. Levelized cost of energy (LCOE) and imported electricity for the investigated systems under four objectives. For each system, the dots from right to left represent objectives A to D, respectively, as the reduction of imported electricity.

presented in Table 7, are considered. The growing power generation of renewable energy is reflected as the increasing wind power productions, while the variable nature of wind power is expressed in the different profiles representing strong and weak production periods. With continuous discussions on the nuclear safety, nuclear power capacities from current level to completely phased-out condition are also included. Moreover, the possible increase in fossil fuel price is also considered, in response to the energy security, political issues, and growing carbon taxes. The fossil fuels are only used for peak power supply during short periods when other sources cannot fulfill the demand.

Similar to the method applied for demand cases, the uncertainties in the power technologies were stochastically combined as input parameters in the ELIN-EPOD model. Then, a set of price profiles were generated. To limit the calculation effort, 45 bought-in price profiles from the grid with unique characteristics were selected for further study, as shown in Fig. 5. The electricity price consists of the fixed part from mainly network fees and variable part from modelling results. The index of price variation expresses the annual proportion of all price differences to the daily average price, which is an important indicator for price fluctuations.

For the renewable electricity generated from the PV panels, the feed-in price to the network is a fixed value throughout the year. The uncertain range of this price is set between 20 €/MWh to 120 €/MWh. For every bought-in price profile, different feed-in prices were stochastically combined for uncertainty and sensitivity analysis.

4. Uncertainty analysis

Based on the uncertain input parameters and system optimization model, huge number of cases are created with MC simulations for uncertainty analysis. The methods for MC simulations, and the following sensitivity analysis and system comparisons are explained in this section.

4.1. Monte Carlo simulations and sensitivity analysis

As presented in Fig. 3, for every demand case with a certain energy system option, 1000*N iterations (energy system optimizations) are conducted. N represents the number of uncertain input parameters, as explained in Table 3. In total, there are around 10,000 iterations for every demand case. The MILP problem is solved in every iteration. This arrangement is a good trade-off between calculation effort and accuracy for uncertainty and sensitivity analysis [57]. The analysis was conducted repetitively for the four energy system options and four design objectives in this study.

In every MC simulation, the input parameters are sampled according

to the probabilistic density functions explained in Section 3. They are considered as independent parameters for the analysis. To express the practical meaning of sensitivity, the indicator of contribution to total system cost is applied, as written in Eq. (5).

$$\sigma(X_n) = \frac{TAC(X_n) - TAC(X_0)}{TAC(X_0)} \quad (5)$$

where X_n and X_0 are the uncertain parameter X at investigated value and reference value, respectively. Thereby, Eq. (5) directly expresses the relatively changes of total annualized cost (TAC) induced by the uncertain parameter X . The results from different uncertain parameters are comparable for sensitivity analysis.

4.2. Cost-saving probability for system comparison

In real projects, the question of “which system costs less” is always asked by decision-makers and relative stakeholders. Unlike previous papers [9,12,16] that dealt with deterministic scenarios, this study aims to stochastically compare the economic performance of future DHC systems by means of MC simulations and uncertainty analysis. The index named cost-saving probability (CSP) is applied to describe the comparison result, as written in Eq. (6).

$$CSP_{A,B} = \frac{\sum (TAC_A(z) \leq TAC_B(z))}{n_A \bullet n_B} \quad (6)$$

where A and B are the two sets of data being compared, referring to the two systems in this study. z represents any case within the two sets. n_A and n_B are the total numbers of cases for sets A and B, respectively, which are explained in Section 4.1. With thousands of MC simulation runs, Eq. (6) expresses the probability of A having less TAC than B. A similar concept for comparing datasets is known as the stochastic ordering, which is further explained in [58]. The CSP between systems is calculated for all scenarios and objectives.

4.3. Key performance indicator

Key performance indicators (KPIs) are presented to find the most influential factors. The sensitivities of KPIs for the ULTDHC and 5GDHC systems are also included, to improve the understanding of DHC system transitions. Linear demand density, as written in Eq. (7), explains the heating and cooling demand on unit length of trench pipe. It is used to distinguish the feasibilities of centralized and de-centralized systems [27].

$$q_l = \frac{Q_{heat} + Q_{cool}}{L} \quad (7)$$

Demand overlap coefficient (DOC) expresses the overlapping heating and cooling demand during a certain period t [7], as written in Eq. (8). This index has been used to identify the economic attractiveness of 5GDHC system [7,17].

$$DOC = \frac{2 \bullet \sum_t \min\{P_{H,t}, P_{C,t}\}}{\sum_t (P_{H,t} + P_{C,t})} \quad (8)$$

To describe the uncertainties in equipment efficiency and equipment investment, an aggregated index named Eff/INV is defined, as written in Eq. (9). This index expresses the heating and cooling source performance on unit investment cost and is applied for evaluating the influence of equipment uncertainties on energy system performance.

$$Eff/INV = \frac{COP}{Investment} \quad (9)$$

5. Results

The optimal design of heating and cooling systems and the

Table 8

Optimal PV capacities under different objectives, expressed as unit floor area values (W/m^2).

Objectives	4GDH	ULTDHC	5GDHC	Individual
OBJB	6.1	4.0	3.7	6.8
OBJC	25.3	12.2	7.2	–
OBJD	33.6	19.9	16.2	–

Table 9

Optimal seasonal TES size under different objectives, expressed as the ratio between storage capacity and annual heating and cooling demand (kWh/kWh).

Objectives	4GDH	ULTDHC	5GDHC
OBJC	23.1%	13.4%	10.2%
OBJD	36.5%	32.4%	32.0%

Table 10

The probabilities of energy systems having larger imported electricity than the targets in objectives C and D.

	4GDHC	ULTDHC	5GDHC
OBJ C	0.4%	0.7%	0.5%
OBJ D	1.9%	7.8%	14.1%

uncertainties.

5.1. Uncertainty analysis

For the four energy systems, the average LCOE and imported electricity of all possible cases under each objective are summarized in Fig. 6. Due to the high costs of large-scale centralized short-term and seasonal TES units, the ability of individual systems to incorporate the local PV electricity is limited. Therefore, the lowest-possible imported electricity index is only 0.21 in the individual systems. The other three DHC systems could achieve the designed target as specified in Table 2. From objective A to objective B, with the installation of PV panels at the least cost way, the overall system LCOE is reduced by around 2%. This result is in line with the current perspective on local PV panel [59], that it is economically feasible if planned properly. The imported electricity index describes how much electricity from the grid is needed to fulfill a certain heating and cooling demand. The individual system has the highest imported electricity index while the 5GDHC has the lowest, reflecting the difference in terms of a whole system efficiency.

With specific targets on electricity usage in objectives C and D, more capacities of PV panels and TES units are needed, regardless of their cost. Thereby, the overall system costs are increased, as shown in Fig. 6. Table 8 and Table 9 present the optimal capacities of PV and seasonal TES, respectively. The optimal capacities of other TES units are discussed in Section 5.4 subsequently. Since the starting imported electricity index in 5GDHC system is already low, i.e., 0.136, the prospects of the extra equipment to achieve the same target are smaller than in the 4GDHC and ULTDHC systems. In consequence, the difference in overall system cost between 4GDHC and 5GDHC is increased from 4 €/MWh in objective A to 13 €/MWh in objective D. Furthermore, the imported electricity target in objective C is easier to achieve for ULTDHC and 5GDHC, compared to the target in objective D. Therefore, there are larger differences in equipment capacities between the energy systems in objective C, creating also larger differences in system costs. The 5GDHC is almost 20 €/MWh cheaper than the 4GDHC. As for the ULTDHC system, the overall cost is between the other two DHC systems, in line with the difference in the needed capacities for extra equipment.

It shall be noted that the results from Fig. 6 only give a general overview of the differences between the studied energy systems. The diversity of their performance, as obtained by the stochastic simulations, are shown in Fig. 7, taking the objectives A and D as examples. For objective A, the 4GDHC and individual systems have wider ranges of LCOE and imported electricity, compared to the other DHC systems. Such finding indicates that the two systems are more vulnerable to uncertain changes, as further explained in Section 5.2. As for the cases with objective D, most of them are grouped within the imported electricity limit, while some cases fail. Table 10 summarizes the percentage shares of these cases that cannot reach the requirement. The main reason associated with the non-conforming cases in ULTDHC and 5GDHC systems is the use of de-centralized equipment including the booster HP, circulation HP, and local chiller. These facilities consume around 12% and 38% of the total electricity demand in the ULTDHC and 5GDHC systems, respectively. Unlike the central TES units, the demand-side TES units have limited applications due to the relatively high investment and limited space use in the buildings [60]. Thereby, the electricity demand from de-centralized equipment is hard to be shifted by demand-side TES to incorporate the available PV power. For the 5GDHC system, with more usage of de-centralized chillers, the imported electricity target is

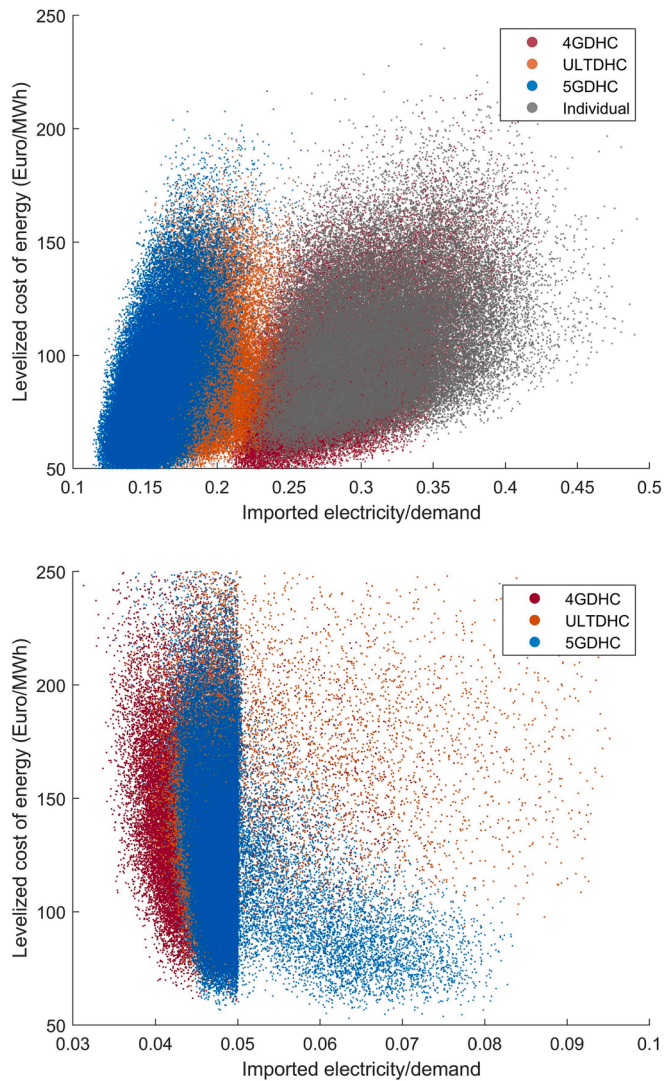

Fig. 7. Scatter plots showing the economic performance (LCOE) and imported electricity of MC simulation results for objective A (upper) and objective D (lower).

probability distributions of economic performance are presented in Section 5.1. The contributions of uncertain parameters to the system performance are shown in Section 5.2. The comparisons of energy systems and the sensitivities on the comparison results are discussed in Section 5.3. Section 5.4 focuses on the applications of TES units under

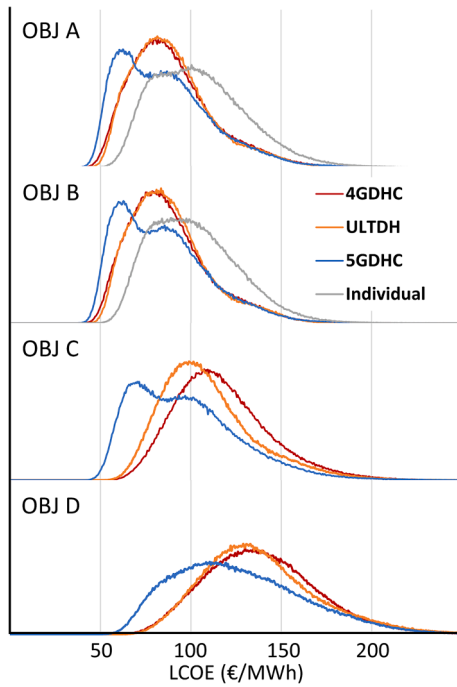

Fig. 8. Probability distribution plots for the levelized cost of energy under different objectives (OBJs). The results for individual system under objectives C and D are not presented. The vertical axis in four subplots have same scale.

more difficult to be achieved, compared to the ULTDHC system. Moreover, the 4GDHC system could be, in theory, self-sufficient with the current TES and PV technologies. For the ULTDHC and 5GDHC systems, more-efficient demand-side energy storage technologies like the household battery are needed, which is further discussed in Section 6.

The probability distributions of system LCOE are shown in Fig. 8. The general shift towards higher costs for lower imported electricity requirement is observed in all systems, in accordance with the results from Fig. 6. The ranges of LCOE are also increased under the objectives C and D, indicating that the system cost is more influenced by uncertainties. The 5GDHC system has higher probability of being cost saving than the other systems. Although the probability distribution curves for 4GDHC and ULTDHC systems are close to each other, the factors contributing to their costs are rather different, creating significantly different and economically preferable scenarios for the investment and operation of the two systems, as further explained in Section

5.3. For individual system, although it is in general more expensive than the other three systems, there are also cases that result in lower overall cost.

5.2. Sensitivity analysis

The uncertainty in demand profile is a complex parameter, which can be split into various KPIs like the demand density and DOC. These KPIs describe the demand profile from different perspectives, but they are not completely independent. Therefore, the overall contributions of demand profiles to the total system cost are analyzed and shown in Fig. 9. In general, the uncertainties in demand profiles alter the system costs by -20% to 20% from the average level of all cases. Comparing energy systems, the 5GDHC has the most influence from demand uncertainties while the 4GDHC has the smallest. The main reasons are revealed by using Spearman’s rank correlation coefficients between different KPIs and the system cost, as presented in Fig. 10.

Among the five investigated KPIs, demand density is the most sensitive parameter for the system cost, especially for the three DHC systems. With more aggregated heating and cooling demand, the initial investment in network and sources is better shared with end-users. By comparison, the influence of demand density is relatively less significant for individual systems. Such difference is further explored for comparing the economic performance of systems in Section 5.3.

The influence of DHW demand share is relatively small compared to other parameters. For depicting the influence of cooling demand, DOC is more related to the system cost than the single index of cooling demand share. Indeed, the DOC can better reflect the dynamic balancing potential of heating and cooling demand and is, thereby, more appropriate for evaluating bi-directional 5GDHC. With larger overlapping demand, the 5GDHC becomes more economically attractive.

The contributions to the system cost by electricity price and equipment investments are summarized in Fig. 11. With objectives A and B, the electricity price has direct impact on the system cost and is the most influential factor. With higher share of PV power in the whole system in objectives C and D, the imported electricity from grid is smaller and the impact of grid price is also smaller. For the four energy system options, a higher efficiency means less electricity consumption and, thereby, less sensitive to price changes. As shown in Fig. 11, the individual system is mostly influenced by electricity price, while the 5GDHC is a robust technology to future price changes.

For simplicity reason, the contributions from the investments in all TES technologies are aggregated and presented in Fig. 11. With strict requirement on renewable energy utilization, the need for seasonal TES to balance the surplus PV power during summer is growing rapidly.

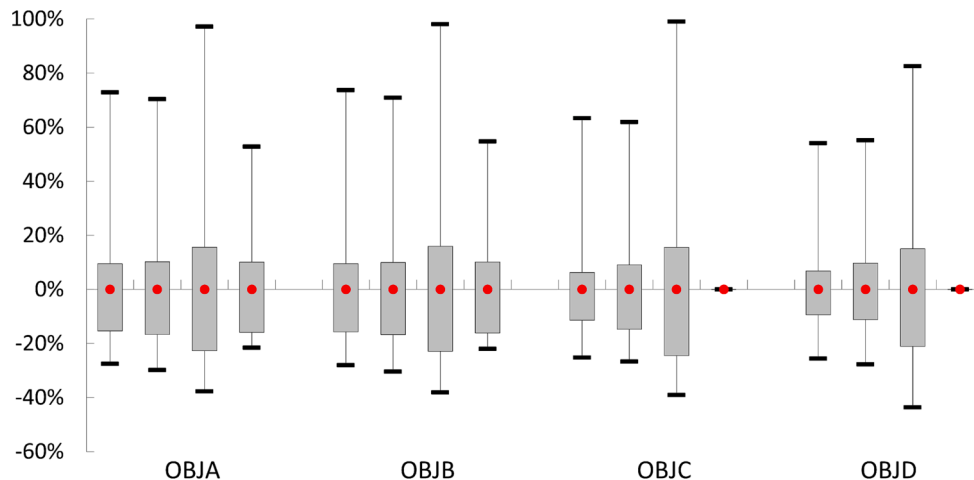

Fig. 9. Contribution to total cost by demand uncertainties. For each objective, the four boxes from left to right represent 4GDHC, ULTDHC, 5GDHC, and individual systems, respectively.

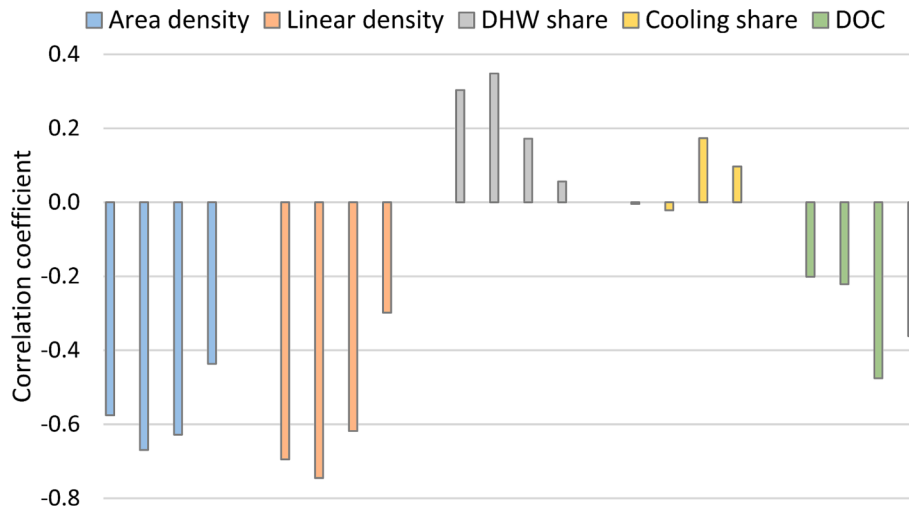

Fig. 10. Spearman's rank correlation coefficients between specific demand KPIs and the total costs, with objective A. The four bars represent four investigated energy systems.

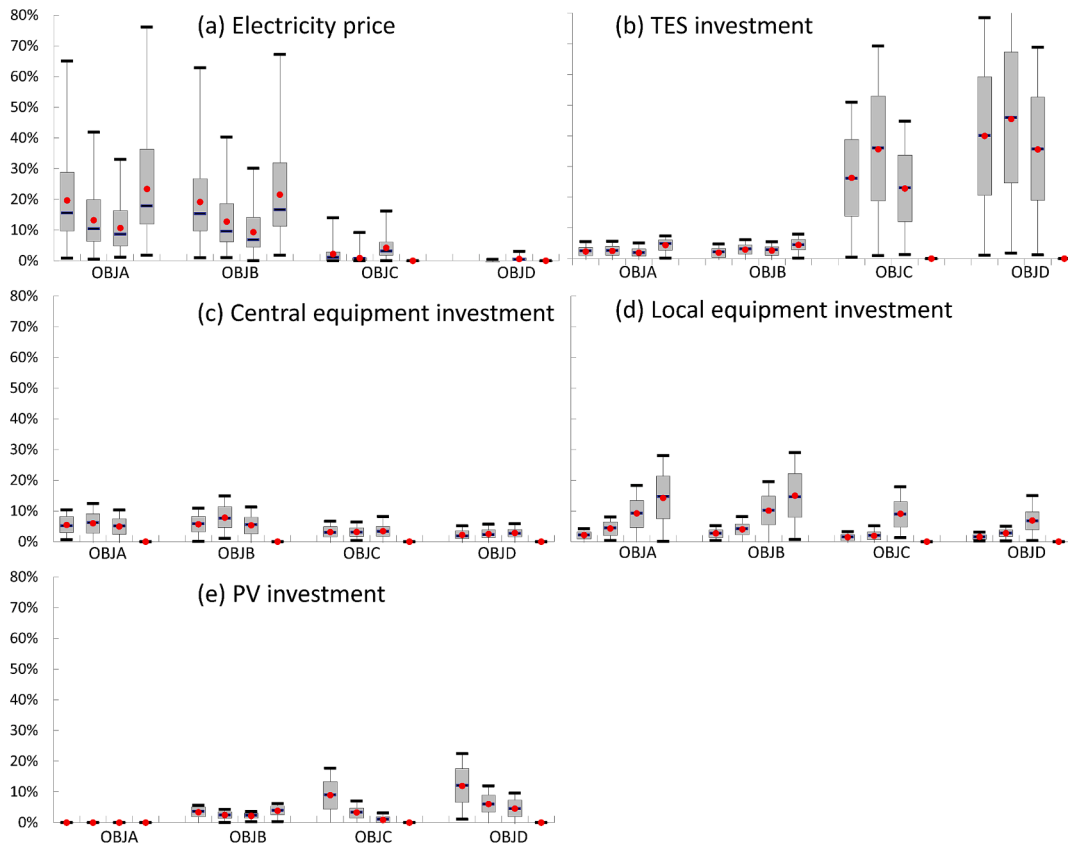

Fig. 11. Box-plot presentations of contributions to the system total cost by electricity prices and equipment investments (from left to right...).

Therefore, under objectives C and D, the contribution of TES investment to the system cost reaches 30% to 60%, mostly driven by the investment in seasonal TES. At the same time, the 4GDHC system has a larger need for PV panels than other systems to reach the same imported electricity target, as presented in Table 8, due to its relatively high electricity consumption. Thereby, the investment in PV panels is more sensitive in the 4GDHC system than in the other systems.

Compared to other factors, the uncertainty associated with the investment in centralized equipment only creates a small change in the total system cost. The main reason is the application of centralized TES

for reducing the peak power and associated cost, as further explained in Section 5.4. The differences between the three district systems are also small. By comparison, the contributions of the investment in local equipment are more obvious, as presented in figure (d) of Fig. 11.

Equipment efficiencies and feed-in price of surplus PV power have negative impact on the overall system cost, as presented in Fig. 12. In general, as the overall system efficiency is improved in ULTDH and 5GDHC systems, the share of OPEX in the overall cost is smaller. In other words, the two systems are more robust to changes in equipment efficiency and electricity price, as discussed earlier. By comparison, the

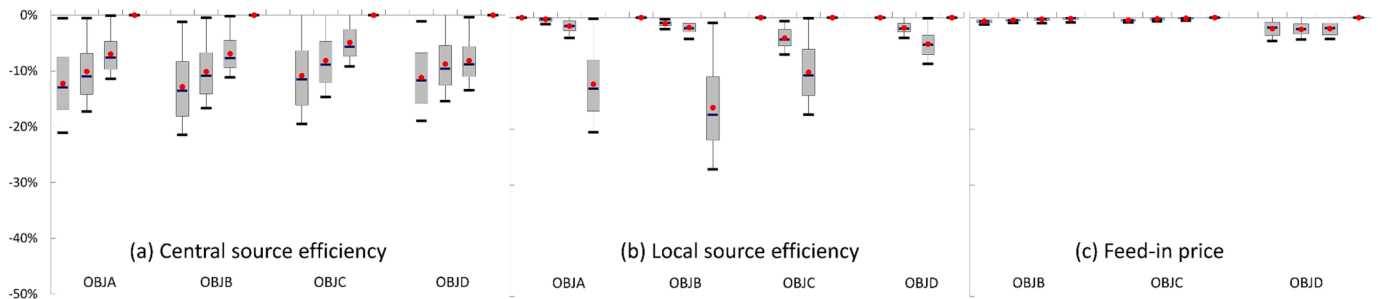

Fig. 12. Box-plot presentations of contributions to the system total cost by equipment efficiencies and feed-in price.

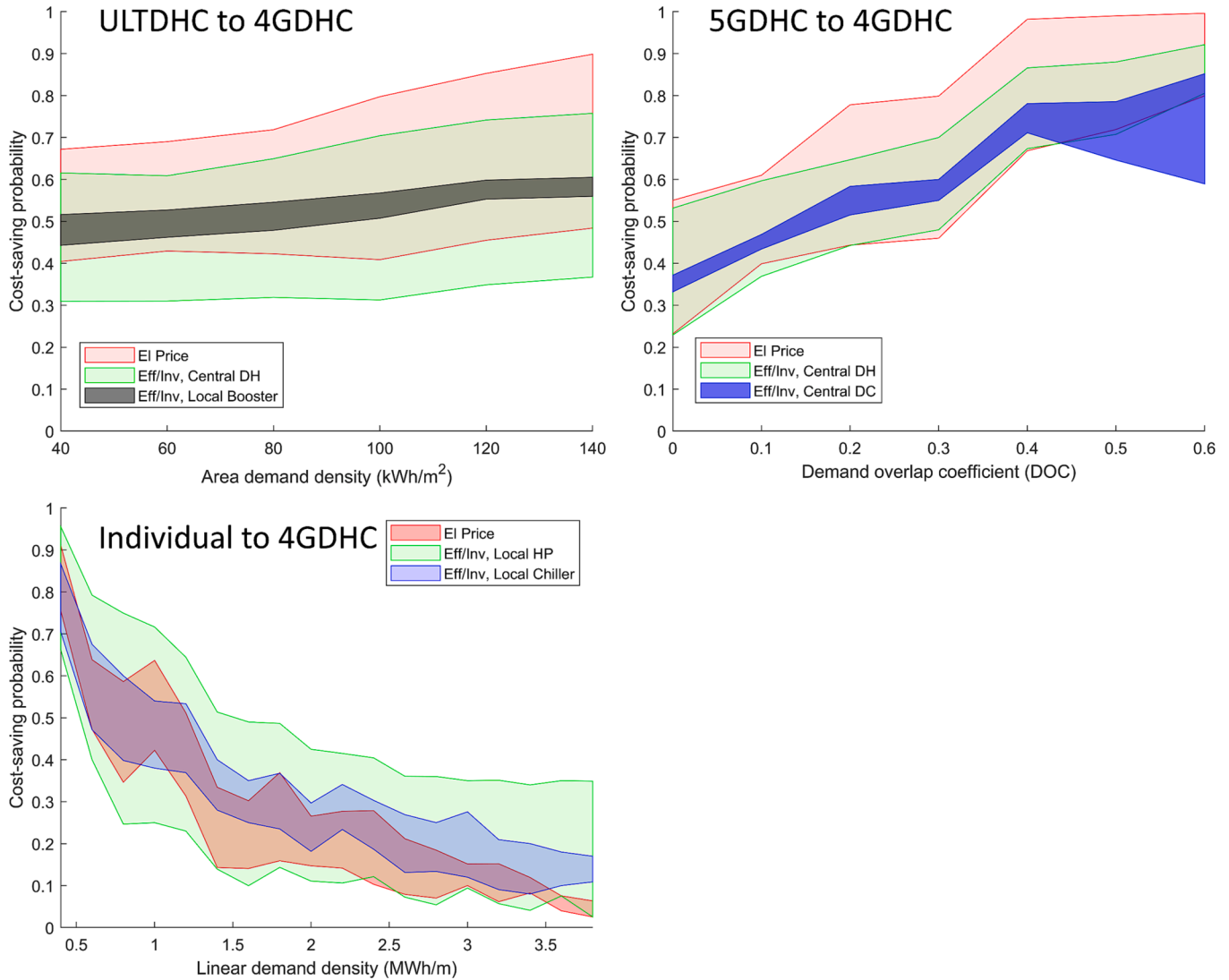

Fig. 13. Cost-saving probabilities of ULTDHC, 5GDHC, and individual systems compared to 4GDHC, with objective A.

individual system is more sensitive to operational conditions and has larger influence from uncertainties in equipment efficiency, as presented in figure (b) of Fig. 12.

Compared to other factors, the influence of feed-in price is small, contributing to less than 5% of the changes in system cost. The main reason is that the surplus PV power is mostly shifted by the TES units and consumed on-site for reducing the imported electricity from grid. For objectives B to D, the shares of feed-in electricity in the total PV production are 18%, 22%, and 25%, respectively. The revenues from selling

the electricity to the grid only contributes to a small part in the total system cost. Without the optimal use of TES units, the influence of feed-in price would be higher.

5.3. Economic comparison between systems

In the planning stage of real projects, the question of “which system performs better” is always asked by related stakeholder. The energy system comparisons are made on cases with objectives A and D, as

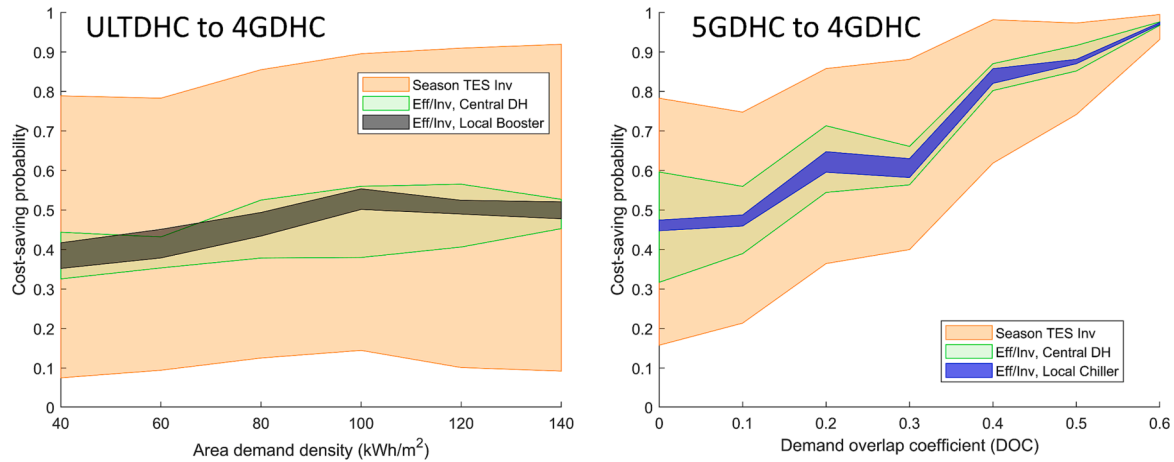

Fig. 14. Cost-saving probabilities of ULTDHC and 5GDHC systems compared to 4GDHC, with objective D.

Table 11

Contributions of PV investment to the cost-saving probabilities of three systems compared to 4GDHC.

Objectives	ULTDH	5GDHC	Individual
OBJ B	2%	3%	1%
OBJ C	8%	7%	–
OBJ D	11%	9%	–

representatives of the economic and environmental targets, respectively. The 4GDHC system is selected as the reference system for comparison because it is widely acknowledged as a robust energy solution.

The CSPs of ULTDHC, 5GDHC, and individual systems compared to the 4GDHC system with objectives A and D are presented in Fig. 13 and Fig. 14, respectively. For every pair-of-systems comparison, the most significant factor, is set on the horizontal axis. The contributions to CSPs

from other factors are painted as different color ranges on the figures. For simplicity reason, only the four most sensitive factors are considered in the system comparisons. The other factors contribute to the system cost by less than 10% and are omitted in the subsequent analysis.

With the least-cost objective A, the CSP of the ULTDHC system compared to the 4GDHC system varies around 50% and is influenced by many factors. As presented in Fig. 8, the probability distribution curves of the total costs of two systems are close to each other. There is no single factor to indicate the economic feasibility in a straightforward manner. However, the area demand density is still an important factor according to Fig. 13. The ULTDHC system is more likely to be cost saving than 4GDHC in the area with high space-heating demand density because the benefit of ultra-low temperature space heating supply can be assured. This is in line with previous studies on the feasibility of ULTDHC [27].

For the 5GDHC system, the DOC is the game-changing factor. With the DOC index higher than 0.4, the 5GDHC is on-average 80% possible

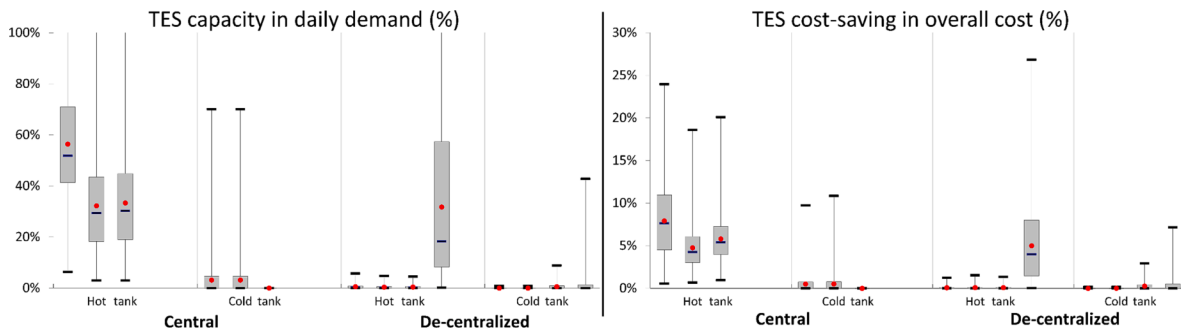

Fig. 15. Box plot presentation of the optimal TES capacities and the cost-saving rates (y-axis) for central and de-centralized water tanks under economic objective A. For each TES type, the systems from 4GDHC to individual are presented from left to right, respectively.

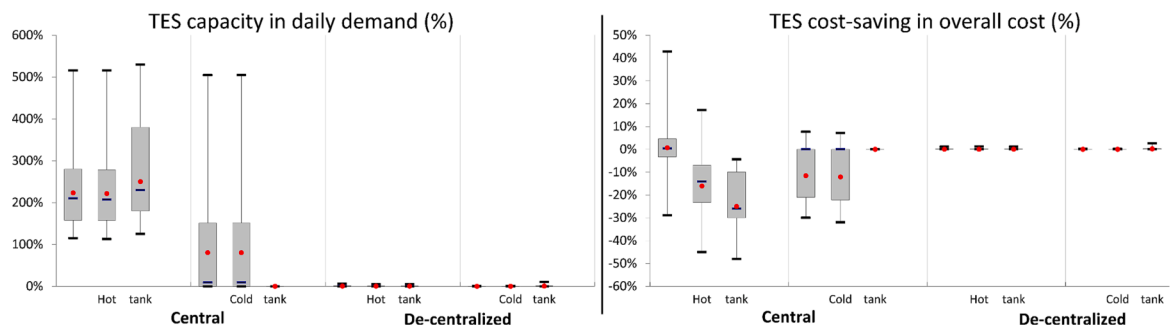

Fig. 16. Box plot presentation of the optimal TES capacities and the cost-saving rates for central and de-centralized water tanks under economic objective D.

Table 12
Optimal TES capacity and the benefits of PV integration and cost-saving for the central hot tank in three DHC systems, with objective D.

Systems	TES capacity in respect to daily demand (%)	Integration of PV power (kWh _{el} /kWh _{demand})	Cost-saving rate (%)
4GDHC	223%	0.067	-3%
ULTDHC	222%	0.031	-16%
5GDHC	250%	0.030	-25%

of being cost-saving compared to the 4GDHC system. Thereby, the DOC could be used as an index to pre-identify the economic performance of 5GDHC [7]. According to the results in Fig. 14, the conclusion is resilient under different objectives.

The electricity price is also an unneglectable factor for both the ULTDHC and 5GDHC system. When the average price is low, the benefits from saved operational expenditure cannot cover the relatively high equipment investment. In consequence, even with a DOC of 0.6, there are still 20% to 30% of occasions that favor the 4GDHC system instead of the 5GDHC. For the ULTDHC system, the electricity price could still alter the CSP by around 40%. Moreover, as the cooling demand grows, the efficiency and cost of cooling equipment becomes increasingly important. As shown in the blue areas in Fig. 13, the cooling equipment replaces the electricity price as the second most sensitive factor for 5GDHC. The results also reveal that the efficiency and cost of local equipment only alter the CSP of ULTDHC and 5GDHC systems by around 10%. Therefore, it can be regarded as a less important factor for decision-makers.

As for the individual system, the most important factor for its economic competitiveness is the linear demand density. With higher density, the cost for the heating and cooling network is more distributed on end-users, which makes centralized system economically attractive. The individual system is at more than 50% occasions more expensive than the 4GDHC, when the linear density is higher than 1 MWh/m. This value is also regarded as the dividing point between a centralized and a decentralized system [61]. Another point to be noted is that the influence of electricity prices is less significant at high demand density, as shown in the red areas in Fig. 13. This means the price is no longer a sensitive factor since the individual system is generally costing more than the 4GDHC system. Moreover, the uncertainties associated with the equipment efficiency and cost could vary the CSP result by 40% and is the second most influential factor after demand density.

With objective D being focused on imported electricity and PV integration, the 5GDHC is in general more likely to be cost-saving than

4GDHC, as explained via the LCOE distribution curves in Fig. 8. However, from another perspective, the system is more vulnerable to uncertain parameters. Indeed, the most sensitive factor is the investment on TES units, especially the seasonal TES. The changes in TES costs could alter the CSP of ULTDHC system by around 75% under all demand cases. For the 5GDHC system, the influence of TES costs is less significant in high DOC cases, as the system becomes more balanced and self-sufficient. Indeed, less TES capacity is needed when DOC is higher. As for other factors, the contributions from electricity price and equipment are generally small. Table 11 summarizes the contributions of PV investment. As with the conclusions in Section 5.2, due to the use of TES units, the PV capacity is optimized and the contribution to overall cost is also relatively small.

5.4. TES applications

The optimal capacities and the benefits of cost-saving for short-term TES units under objectives A and D are presented in Fig. 15 and Fig. 16, respectively. Besides, the optimal capacities of long-term seasonal TES have been already introduced in Table 9.

For DHC systems, the demand-side or decentralized water tanks operate as small buffer tanks for peak power shaving only due to their relatively high initial investment. However, due to the absence of centralized network and facilities in individual systems, the decentralized water tank is still an important measure, which on-average reduces around 5% of the total system cost.

With the economic objective A, the optimal capacity of central water tank corresponds to around 30% to 50% of the average daily demand. The tank is mainly used for shifting the diurnal demand to utilize the variable electricity prices and surplus PV power. However, as required by the limit on imported electricity in objective D, larger capacities of water tanks are needed to balance the demand and surplus PV power for up to 5 days, as shown in Fig. 16. In consequence, the TES is no longer a cost-saving measure because it increases the overall system cost by 10%

Table A1
Ranges of key parameters of the investigated buildings.

Item	Value ranges	Unit
Floors	3 ~ 6	-
U-value, walls	0.3 ~ 1.2	(W/m ² ·K)
U-value, windows	1.0 ~ 2.0	(W/m ² ·K)
U-value, roof	0.3 ~ 1.0	(W/m ² ·K)
Ventilation rate	0.4 ~ 1.0	h ⁻¹
Heat recovery efficiency	0%~60%	-

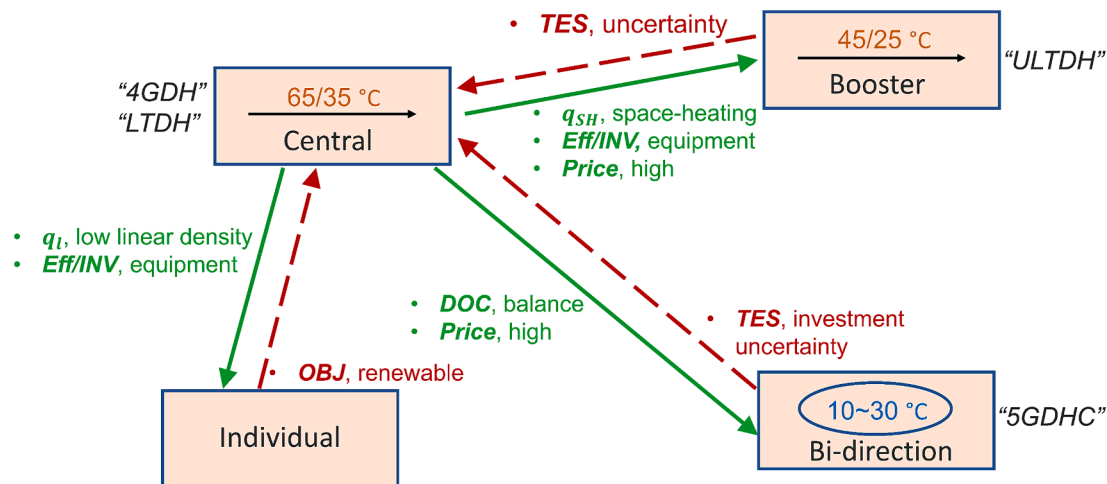

Fig. 17. Roadmaps for energy system transitions identified through the promoting (green) and hindering factors (red). (For interpretation of the references to color in this figure legend, the reader is referred to the web version of this article.)

to 30%. This also explains the reason for the TES investment becoming sensitive under objectives C and D, according to the results of sensitivity analysis in Fig. 11.

Comparing the central TES applications among DHC systems, the optimal capacities and the benefits of PV integration and cost-saving with objective D are summarized in Table 12. Although the optimal TES capacity is similar among these three systems, the integration of PV power and the cost-saving rate are much lower in the ULTDHC and 5GDHC systems. As the energy efficiency is improved in these two systems, the heat-to-power ratio is also increased. This means more heat storage capacity is needed to shift the same target electricity. Besides, the energy storage density is also reduced in ULTDHC and 5GDHC systems because the supply water temperature and the storage temperature difference are reduced. Thereby, in DHC systems with lower water temperature and higher efficiency, the synergy between electricity and heat is more difficult to be achieved with TES.

It can be foreseen that if stricter requirement on imported electricity or PV power integration is set, the ULTDHC and 5GDHC system would have much more extensive use on TES units. In consequence, not only would the overall system cost be increased, but it would also have a larger uncertainty compared to the 4GDHC system due to the influence of TES investment.

6. Discussion

Based on the results from the sensitivity analysis and system comparisons presented earlier, the key factors for the transitions towards the ULTDHC, 5GDHC and individual systems are summarized in Fig. 17. In accordance with the comparisons in Section 5.3, the 4GDHC system is set as the reference system. For the ULTDHC and 5GDHC systems with large investment and high energy efficiency, the possible high electricity price in the future favors their applications because the savings from operational cost can cover the investment. The specific promoting factor for the ULTDHC system is the high space-heating demand density because it highlights the benefit from lowering the supply water temperature. The overlapping heating and cooling demand, as presented with the DOC index, to a large extent decides the transition towards the bi-directional 5GDHC system. Due to the limited roles of TES in achieving power-and-heat synergy in the ULTDHC and 5GDHC system, the uncertainties with the TES cost are possible hindering factors in the future for these new DHC systems.

The individual system is mostly applicable in the area with low demand density. Improvements in the equipment efficiency and costs can also increase the feasibility of individual solution but only to a limited extent. Due to the difficulty of applying large-scale centralized TES units, the integration of renewable energy is much harder to be achieved in the individual system compared to other systems.

The perspectives from the lowest system cost and the lowest imported electricity are investigated in this study. With growing calls for carbon emission reduction and the evolving policies and markets for the renewable energy, there will be more diverse objectives for energy system design. For example, some urban districts might have the target of net-zero energy, where the electricity production by local renewable energy is larger than the imported electricity from the grid. With the changing global politics and energy prices, the security of energy supply and the self-sufficiency of urban district attract growing attentions. Such target calls for resilient design of the DHC systems and energy storage units. The sensitive factors under these future objectives require further investigations, to provide more robust suggestions for decision-makers.

The TES is applied to shift the demand and utilize renewable energy in this study. However, it shall be noted that there are also other measures to increase the flexibility of energy systems, such as the battery and demand management. They are not considered because they belong to the topics of complex energy system or energy hub [62], where multiple energy carriers, conversions, and storages co-exist. The focus of this work is on the transitions of heating and cooling systems. However, as

pointed out in [63], the smart synergy between the heating, cooling, electricity, and transportation sectors is a resilient and cost-saving pathway to achieve the 100% renewable energy future. The uncertainties and sensitive factors in the smart energy systems shall be thus carefully considered.

7. Conclusion

This paper presents a five-step framework for evaluating the uncertainties and their sensitivities in different district heating and cooling system configurations. In the first step, a MILP model is developed based on simplified DHC systems to optimize the energy system design and operation. In the second step, four objectives, as representatives of different economic and environmental targets for designing the energy system, are identified. The characteristics of major uncertain parameters, including the demand profiles, energy prices, investment costs and equipment efficiencies, are described in the third step. With a large number of MC simulation runs, the fourth step evaluates the uncertainties in the energy system performance and quantifies the sensitivities. Finally, in the fifth step, with the CSP index, the energy systems are compared based on a variety of stochastic cases. The sensitive factors for making choice between energy systems are also quantified. Using this framework, the main question about which factors drive the transitions of heating and cooling systems is answered in this study. Key conclusions from the analysis are summarized as follows:

1) With the least system cost objective, the overall costs of the four investigated energy systems are close to each other. As the limits on imported electricity and renewable energy integrations are set, larger differences between systems are found. In general, the 5GDHC system has the lowest costs over the investigated cases. However, it cannot reach self-sufficiency due to the difficulty of shifting electricity demand from local equipment.

2) The demand profile and electricity price are the two most sensitive factors for the DHC systems, followed by the equipment efficiency and investment. The TES investment becomes the most important factor when the objectives on renewable energy integration are set. Compared to DHC systems, the individual system is more sensitive to changes in equipment efficiency and cost.

3) The area demand density, DOC, and linear demand density are the most influential factors for the decision-making about transitions to the ULTDHC, 5GDHC, and individual systems respectively, when compared with the 4GDHC system. A roadmap summarizing the promoting and hindering factors for the energy system transition is provided.

4) In DHC systems with lower water temperature and higher efficiency, the flexibility provided by the TES is limited, making the synergy between electricity and heat more difficult to be achieved. The main reasons are the high power-to-heat ratio and reduced heat storage density. As more TES capacities are needed, the influences of uncertain TES investment are also increased, which to a large extent change the economic attractiveness of these systems.

CRedit authorship contribution statement

Yichi Zhang: Methodology, Validation, Investigation, Formal analysis, Writing – original draft. **Pär Johansson:** Conceptualization, Writing – review & editing, Supervision. **Angela Sasic Kalagasidis:** Conceptualization, Resources, Writing – review & editing, Supervision.

Declaration of Competing Interest

The authors declare that they have no known competing financial interests or personal relationships that could have appeared to influence the work reported in this paper.

Data availability

The data that has been used is confidential.

Acknowledgement

This work was supported by the Swedish Research Council for

Appendix

Appendix A1. TES models

For TES units, the design sizes and operation schemes are optimized to reach the objective as specified in Section 2.2. To ease the optimization process, the TES units are linearized with plug-flow model, as written in Eqs. (10) - (11). For every time step τ , the demand is fulfilled by energy supply from sources $P_{source,\tau}$ and discharged energy from TES $P_{discharge,\tau}$. Eq. (11) expresses the constraints for the state-of-charge (SOC) of TES.

$$P_{source,\tau} + P_{discharge,\tau} \geq P_{demand,\tau} \quad (10)$$

$$SOC_{min} \leq SOC_{\tau} + (P_{charge,\tau} - P_{discharge,\tau} - P_{TES,loss})\Delta t \leq SOC_{max} \quad (11)$$

For the short-term central and de-centralized storage tanks, a time constant of 2 h is applied, which means that the tank can be fully charged or discharged in 2 h. Therefore, the maximum power is specified in relation to the tank size. The SOC ranges reflect the proportion of the storage capacity that can be used due to water mixtures and temperature level degradation [64]. Based on previous works on thermally stratified tanks [65], it is assumed that 80% of the storage capacity could be practically utilized. To calculate heat losses, the heat loss rate of 0.6 W/(m²·K) is applied. The central water tanks are placed outdoors and the small de-centralized water tanks are placed in the unheated indoor area such as the warehouse with an environmental temperature of 15 °C [66].

For the pit TES, a round-trip efficiency of 70% is set in this study, based on the experiences from operating projects [67]. This means that only 70% of the charged energy can be eventually discharged, due to thermal losses to the environment. The model of the pit TES is similar to that of the central water tank, while the charging and discharging period is set as the summer and winter, respectively Table A1.

Appendix A2. Building characteristics

Uniform distribution is applied for the building parameters.

References

- [1] European Commission Eurostat - Statistics database 2021. <http://ec.europa.eu/eurostat>.
- [2] European Commission. Energy and the Green Deal 2020. https://ec.europa.eu/info/strategy/priorities-2019-2024/european-green-deal/energy-and-green-deal_en (accessed April 7, 2022).
- [3] Lund H, Werner S, Wiltshire R, Svendsen S, Eric J, Hvelplund F, et al. 4th Generation District Heating (4GDH) Integrating smart thermal grids into future sustainable energy systems. *Energy* 2014;68:1–11. <https://doi.org/10.1016/j.energy.2014.02.089>.
- [4] Lund H, Østergaard PA, Chang M, Werner S, Svendsen S, Sorknæs P, et al. The status of 4th generation district heating: Research and results. *Energy* 2018;164: 147–59. <https://doi.org/10.1016/j.energy.2018.08.206>.
- [5] Averfalk H, Benakopoulos T, Best I, Dammel F, Engel C, Geyer R, et al. Low-Temperature District Heating Implementation Guidebook. IEA DHC Annex TS2 Implement 2021:201.
- [6] Wirtz M, Kivilip L, Remmen P, Müller D. 5th Generation District Heating: A novel design approach based on mathematical optimization. *Appl Energy* 2020;260: 114158. <https://doi.org/10.1016/j.apenergy.2019.114158>.
- [7] Wirtz M, Kivilip L, Remmen P, Müller D. Quantifying Demand Balancing in Bidirectional Low Temperature Networks. *Energy Build* 2020;224:110245. <https://doi.org/10.1016/j.enbuild.2020.110245>.
- [8] Pellegrini M, Bianchini A. The innovative concept of cold district heating networks: A literature review. *Energies* 2018;11. <https://doi.org/10.3390/en11010236>.
- [9] Buffa S, Cozzini M, D'Antoni M, Barattieri M, Fedrizzi R. 5th generation district heating and cooling systems: A review of existing cases in Europe. *Renew Sustain Energy Rev* 2019;104:504–22. <https://doi.org/10.1016/j.rser.2018.12.059>.
- [10] Lund H, Østergaard PA, Nielsen TB, Werner S, Thorsen JE, Gudmundsson O, et al. Perspectives on fourth and fifth generation district heating. *Energy* 2021;227: 120520. <https://doi.org/10.1016/j.energy.2021.120520>.
- [11] Larsen MAD, Petrović S, Radoszynski AM, McKenna R, Balyk O. Climate change impacts on trends and extremes in future heating and cooling demands over Europe. *Energy Build* 2020;226. <https://doi.org/10.1016/j.enbuild.2020.110397>.
- [12] Lindhe J, Javed S, Johansson D, Bagge H. A review of the current status and development of 5GDHC and characterization of a novel shared energy system. *Sci Technol Built Environ* 2022;28:595–609. <https://doi.org/10.1080/23744731.2022.2057111>.
- [13] Bünning F, Wetter M, Fuchs M, Müller D. Bidirectional low temperature district energy systems with agent-based control: Performance comparison and operation optimization. *Appl Energy* 2018;209:502–15. <https://doi.org/10.1016/j.apenergy.2017.10.072>.
- [14] Franzén I, Nedar L, Andersson M. Environmental Comparison of Energy Solutions for Heating and Cooling. *Sustain* 2019;11. <https://doi.org/10.3390/su11247051>.
- [15] Meuer J, Lamaro F, Vetterli N. Embedding energy optimization in organizations: A case study of a Swiss decentralized renewable energy system. *Energy Build* 2021; 235:110710. <https://doi.org/10.1016/j.enbuild.2020.110710>.
- [16] Millar MA, Elrick B, Jones G, Yu Z, Burnside NM. Roadblocks to low temperature district heating. *Energies* 2020;13. <https://doi.org/10.3390/en13225893>.
- [17] Zhang Y, Johansson P, Sasic KA. Assessment of district heating and cooling systems transition with respect to future changes in demand profiles and renewable energy supplies. *Energy Convers Manag* 2022;268:116038. <https://doi.org/10.1016/j.enconman.2022.116038>.
- [18] Allen A, Henze G, Baker K, Pavlak G. Evaluation of low-exergy heating and cooling systems and topology optimization for deep energy savings at the urban district level. *Energy Convers Manag* 2020;222:113106. <https://doi.org/10.1016/j.enconman.2020.113106>.
- [19] Gudmundsson O, Schmidt RR, Dyrelund A, Thorsen JE. Economic comparison of 4GDH and 5GDH systems – Using a case study. *Energy* 2022;238:121613. <https://doi.org/10.1016/j.energy.2021.121613>.
- [20] Zarin Pass R, Wetter M, Piette MA. A thermodynamic analysis of a novel bidirectional district heating and cooling network. *Energy* 2018;144:20–30. <https://doi.org/10.1016/j.energy.2017.11.122>.
- [21] Prasanna A, Dorer V, Vetterli N. Optimisation of a district energy system with a low temperature network. *Energy* 2017;137:632–48. <https://doi.org/10.1016/j.energy.2017.03.137>.
- [22] Revesz A, Dunham C, Jones P, Bond C, Fenner R, Moody S, et al. A holistic design approach for 5th generation smart local energy systems: Project GreenSCIES. *Energy* 2022;242:122885. <https://doi.org/10.1016/j.energy.2021.122885>.
- [23] Vivian J, Chinello M, Zarrella A, De Carli M. Investigation on Individual and Collective PV Self-Consumption for a Fifth Generation District Heating Network. *Energies* 2022;15. <https://doi.org/10.3390/en15031022>.
- [24] Østergaard PA, Andersen AN. Economic feasibility of booster heat pumps in heat pump-based district heating systems. *Energy* 2018;155:921–9. <https://doi.org/10.1016/j.energy.2018.05.076>.
- [25] Østergaard PA, Andersen AN. Booster heat pumps and central heat pumps in district heating. *Appl Energy* 2016;184:1374–88. <https://doi.org/10.1016/j.apenergy.2016.02.144>.

- [26] Lund R, Østergaard DS, Yang X, Mathiesen BV. Comparison of low-temperature district heating concepts in a long-term energy system perspective. *Int J Sustain Energy Plan Manag* 2017;12:5–18. <https://doi.org/10.5278/ijsepm.2017.12.2>.
- [27] Meesenburg W, Ommen T, Thorsen JE, Elmegaard B. Economic feasibility of ultra-low temperature district heating systems in newly built areas supplied by renewable energy. *Energy* 2020;191:116496. <https://doi.org/10.1016/j.energy.2019.116496>.
- [28] Ommen T, Thorsen JE, Markussen WB, Elmegaard B. Performance of ultra low temperature district heating systems with utility plant and booster heat pumps. *Energy* 2017;137:544–55. <https://doi.org/10.1016/j.energy.2017.05.165>.
- [29] Hammer A, Kienberger T, Haslinger E, Götzl G, Ponweiser K, Biermayr P, et al. Low-temperature heating and cooling grids based on shallow geothermal methods for urban areas. *Proc World Geotherm Congr 2020, Reykjavik, Iceland, 2020:1–9*.
- [30] MacDonald I, Strachan P. Practical application of uncertainty analysis. *Energy Build* 2001;33:219–27. [https://doi.org/10.1016/S0378-7788\(00\)00085-2](https://doi.org/10.1016/S0378-7788(00)00085-2).
- [31] Groen EA, Bokkers EAM, Heijungs R, de Boer IJM. Methods for global sensitivity analysis in life cycle assessment. *Int J Life Cycle Assess* 2017;22:1125–37. <https://doi.org/10.1007/s11367-016-1217-3>.
- [32] Mavromatidis G, Orehounig K, Carmeliet J. Uncertainty and global sensitivity analysis for the optimal design of distributed energy systems. *Appl Energy* 2018; 214:219–38. <https://doi.org/10.1016/j.apenergy.2018.01.062>.
- [33] Petkov I, Gabrielli P. Power-to-hydrogen as seasonal energy storage: an uncertainty analysis for optimal design of low-carbon multi-energy systems. *Appl Energy* 2020; 274:115197. <https://doi.org/10.1016/j.apenergy.2020.115197>.
- [34] Testi D, Urbanucci L, Giola C, Schito E, Conti P. Stochastic optimal integration of decentralized heat pumps in a smart thermal and electric micro-grid. *Energy Convers Manag* 2020;210:112734. <https://doi.org/10.1016/j.enconman.2020.112734>.
- [35] Ciampi G, Rosato A, Sibilio S. Thermo-economic sensitivity analysis by dynamic simulations of a small Italian solar district heating system with a seasonal borehole thermal energy storage. *Energy* 2018;143:757–71. <https://doi.org/10.1016/j.energy.2017.11.029>.
- [36] Reboljar JV, Himpe E, Janssens A. Performance Evaluation of a Low Temperature District Heating System Based on Simulation. *International Building Performance Simulation Association (IBPSA): Uncertainty and Sensitivity Analysis. Int. Build. Perform. Simul.*; 2013.
- [37] Jangsten M, Filipsson P, Lindholm T, Dalenbäck JO. High Temperature District Cooling: Challenges and Possibilities Based on an Existing District Cooling System and its Connected Buildings. *Energy* 2020:199. <https://doi.org/10.1016/j.energy.2020.117407>.
- [38] Vivian J, Emmi G, Zarrella A, Jobard X, Pietruschka D, De Carli M. Evaluating the cost of heat for end users in ultra low temperature district heating networks with booster heat pumps. *Energy* 2018;153:788–800. <https://doi.org/10.1016/j.energy.2018.04.081>.
- [39] Zhang Y, Johansson P, Kalagasidis AS. Applicability of thermal energy storage in future low-temperature district heating systems – Case study using multi-scenario analysis. *Energy Convers Manag* 2021:244. <https://doi.org/10.1016/j.enconman.2021.114518>.
- [40] Persson U, Werner S. Heat distribution and the future competitiveness of district heating. *Appl Energy* 2011;88:568–76. <https://doi.org/10.1016/j.apenergy.2010.09.020>.
- [41] Romanchenko D, Kensby J, Odenberger M, Johnsson F. Thermal energy storage in district heating: Centralised storage vs. storage in thermal inertia of buildings. *Energy Convers Manag* 2018;162:26–38. <https://doi.org/10.1016/j.enconman.2018.01.068>.
- [42] Jordan U, Vajen K. Realistic domestic hot-water profiles in different time scales. *Rep Sol Heat Cool Progr Int Energy Agency (IEA-SHC)Task* 2001;26:1–18.
- [43] Lund H, Østergaard PA, Connolly D, Mathiesen BV. Energy storage and smart energy systems. *Int J Sustain Energy Plan Manag* 2017;137:556–65. <https://doi.org/10.1016/j.energy.2017.05.123>.
- [44] European Commission. Photovoltaic geographical information system-interactive maps 2014. https://re.jrc.ec.europa.eu/pvg_tools/en/tools.html (accessed March 1, 2022).
- [45] Zhang X, Penaka SR, Giriraj S, Sánchez MN, Civiero P, Vandevyvere H. Characterizing positive energy district (Ped) through a preliminary review of 60 existing projects in Europe. *Buildings* 2021;11:1–24. <https://doi.org/10.3390/buildings11080318>.
- [46] Stigler SM. *The History of Statistics: The Measurement of Uncertainty Before 1900*. Harvard University Press; 1986.
- [47] Maivel M, Kurnitski J. Heating system return temperature effect on heat pump performance. *Energy Build* 2015;94:71–9. <https://doi.org/10.1016/j.enbuild.2015.02.048>.
- [48] Danish Energy Agency and Energinet. *Technology Data - Energy Plants for Electricity and District heating generation First 2022*.
- [49] Madonna F, Bazzocchi F. Annual performances of reversible air-to-water heat pumps in small residential buildings. *Energy Build* 2013;65:299–309. <https://doi.org/10.1016/j.enbuild.2013.06.016>.
- [50] Reinholdt L, Kristófersson J, Zühlsdorf B, Elmegaard B, Jensen J, Ommen T, et al. Heat pump COP, part 1: Generalized method for screening of system integration potentials. *Refrig Sci Technol* 2018;2018-June:1207–13. 10.18462/iir.gl.2018.1380.
- [51] R LA, A J-W, M V, B S, D M, M J, et al. ETRI 2014 - Energy Technology Reference Indicator projections for 2010-2050. Luxembourg (Luxembourg): Publications Office of the European Union; 2014. 10.2790/057687.
- [52] Danish Energy Agency and Energinet. *Technology Data – Energy storage*. 2018.
- [53] Best I, Orozsaliev J, Vajen K. Economic comparison of low-temperature and ultra-low-temperature district heating for new building developments with low heat demand densities in Germany. *Int J Sustain Energy Plan Manag* 2018;16:45–60. <https://doi.org/10.5278/ijsepm.2018.16.4>.
- [54] Kan X, Hedenus F, Reichenberg L. The cost of a future low-carbon electricity system without nuclear power – the case of Sweden. *Energy* 2020;195:117015. <https://doi.org/10.1016/j.energy.2020.117015>.
- [55] Göransson L, Goop J, Unger T, Odenberger M, Johnsson F. Linkages between demand-side management and congestion in the European electricity transmission system. *Energy* 2014;69:860–72. <https://doi.org/10.1016/j.energy.2014.03.083>.
- [56] Romanchenko D, Odenberger M, Göransson L, Johnsson F. Impact of electricity price fluctuations on the operation of district heating systems: A case study of district heating in Göteborg, Sweden. *Appl Energy* 2017;204:16–30. <https://doi.org/10.1016/j.apenergy.2017.06.092>.
- [57] Saltelli A, Ratto M, Andres T, Campolongo F, Cariboni J, Gatelli D, et al. *Global sensitivity analysis: the primer*. John Wiley & Sons; 2008.
- [58] Volodina V, Wheatcroft E, Wynn H. Comparing district heating options under uncertainty using stochastic ordering. *Sustain Energy, Grids Netw* 2022;30: 100634. <https://doi.org/10.1016/j.segan.2022.100634>.
- [59] Mokhtara C, Negrou B, Setrou N, Bouferrouk A, Yao Y. Optimal design of grid-connected rooftop PV systems: An overview and a new approach with application to educational buildings in arid climates. *Sustain Energy Technol Assessments* 2021;47:101468. <https://doi.org/10.1016/j.seta.2021.101468>.
- [60] Zhang Y, Johansson P, Kalagasidis AS. Techno-economic assessment of thermal energy storage technologies for demand-side management in low-temperature individual heating systems. *Energy* 2021;236:121496. <https://doi.org/10.1016/j.energy.2021.121496>.
- [61] Reidhav C, Werner S. Profitability of sparse district heating. *Appl Energy* 2008;85: 867–77. <https://doi.org/10.1016/j.apenergy.2008.01.006>.
- [62] Mohammadi M, Noorollahi Y, Mohammadi-ivatloo B, Yousefi H. Energy hub: From a model to a concept – A review. *Renew Sustain Energy Rev* 2017;80:1512–27. <https://doi.org/10.1016/j.rser.2017.07.030>.
- [63] Mathiesen BV, Lund H, Connolly D, Wenzel H, Østergaard PA, Möller B, et al. Smart Energy Systems for coherent 100% renewable energy and transport solutions. *Appl Energy* 2015;145:139–54. <https://doi.org/10.1016/j.apenergy.2015.01.075>.
- [64] Floss A, Hofmann S. Optimized integration of storage tanks in heat pump systems and adapted control strategies. *Energy Build* 2015;100:10–5. <https://doi.org/10.1016/j.enbuild.2015.01.009>.
- [65] Fertahi S ed D, Jamil A, Benbassou A. Review on Solar Thermal Stratified Storage Tanks (STSST): Insight on stratification studies and efficiency indicators. *Sol Energy* 2018;176:126–45. 10.1016/j.solener.2018.10.028.
- [66] Cruickshank CA, Harrison SJ. Heat loss characteristics for a typical solar domestic hot water storage. *Energy Build* 2010;42:1703–10. <https://doi.org/10.1016/j.enbuild.2010.04.013>.
- [67] Hesaraki A, Holmberg S, Haghghat F. Seasonal thermal energy storage with heat pumps and low temperatures in building projects - A comparative review. *Renew Sustain Energy Rev* 2015;43:1199–213. <https://doi.org/10.1016/j.rser.2014.12.002>.