



## **Dynamic Supply Modulation of a 6 - 12 GHz Transmit Array**

Downloaded from: <https://research.chalmers.se>, 2026-04-04 04:58 UTC

Citation for the original published paper (version of record):

Nogales, C., Marzall, L., Lasser, G. et al (2023). Dynamic Supply Modulation of a 6 - 12 GHz Transmit Array. 2023 IEEE Wireless and Microwave Technology Conference, WAMICON 2023: 140-143. <http://dx.doi.org/10.1109/WAMICON57636.2023.10124905>

N.B. When citing this work, cite the original published paper.

© 2023 IEEE. Personal use of this material is permitted. Permission from IEEE must be obtained for all other uses, in any current or future media, including reprinting/republishing this material for advertising or promotional purposes, or reuse of any copyrighted component of this work in other works.

# Dynamic Supply Modulation of a 6 – 12 GHz Transmit Array

Connor Nogales\*, Laila Marzall\*, Gregor Lasser†, Zoya Popović\*

\*Department of Electrical Engineering

University of Colorado Boulder, Colorado, USA

Email: connor.nogales@colorado.edu, laila.marzall@colorado.edu, zoya.popovic@colorado.edu

†Department of Microtechnology and Nanoscience

Chalmers University of Technology, Gothenburg, Sweden

Email: gregor.lasser@chalmers.se

**Abstract**—This paper presents dynamic supply modulation results of a broadband 6–12 GHz  $4 \times 1$  transmit antenna array. The four 2-W GaN MMIC PAs share a 4-level GaN MMIC dynamic power supply. A single GaN MMIC PA is first characterized at 6.5 and 11.5 GHz, and its efficiency while tracking a 10-MHz signal is compared to static drain supply performance, showing 10 percentage point (pp) average efficiency improvement. Four such PAs are then assembled in a modular array of broadband double-ridge dielectrically-loaded horn antennas and characterized under supply modulation. The measured average efficiency when each of the four PAs are terminated with  $50 \Omega$  is compared to when the PAs are loaded with the antenna array. An average PAE improvement of 3.4 pp is achieved over the static case with the supply modulated array at 6.5 GHz when amplifying a 10-MHz 10.7-dB peak-to-average power ratio (PAPR) signal, not taking the  $>80\%$  efficient modulator into account. Linearity is characterized in terms noise power ratio (NPR) of the individual PAs, and at 6.5 GHz the improvement ranges from 2 to 6 dB, depending on the PA. To the best of the authors’ knowledge, this is the first demonstration of dynamic supply modulation for broadband array efficiency and linearity enhancement.

**Index Terms**—Array, Envelope Tracking, GaN, Power Amplifiers, Supply Modulation.

## I. INTRODUCTION

Modern communication and electronic warfare applications demand transmit arrays capable of amplifying broadband signals, with a high peak-to-average power ratio (PAPR) over a large RF bandwidth. Also, thermal limitations in arrays require high-efficiency power amplifiers (PAs).

A technique to improve back-off efficiency is supply modulation, also referred to as envelope tracking. In this approach, the drain bias voltage of the PA is changed dynamically according to the signal envelope [1]. In this paper, supply modulation of a  $4 \times 1$  broadband 6–12 GHz array of active transmit antennas is demonstrated using a single supply modulator, as shown in the block diagram of Fig. 1a, with the modular implementation shown in Fig. 1b. This approach does not introduce additional complexity to the individual PAs in the array and has the benefit of improving the overall heat dissipation in the PA elements,

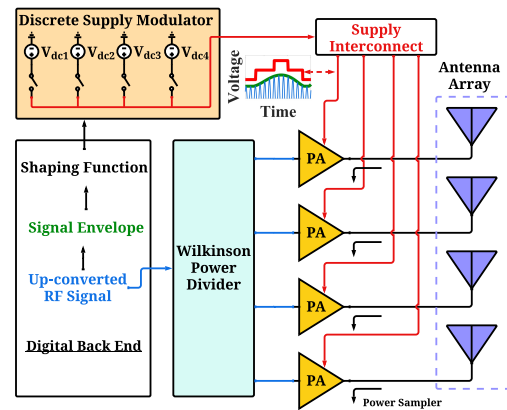

(a)

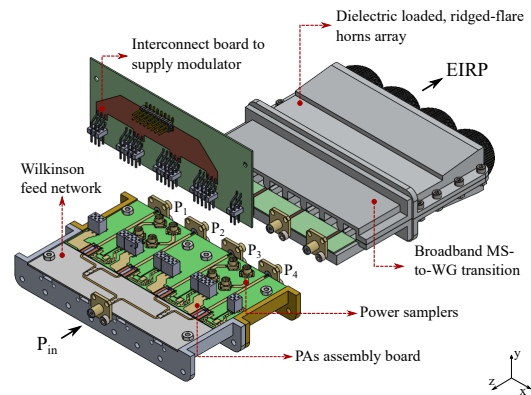

(b)

Fig. 1. (a) Block diagram of a 4-element transmit array with supply modulation for efficiency enhancement of the GaN MMIC PAs, using a single dynamic supply, also implemented as a GaN MMIC. The output of the 4-level discrete supply modulator is time aligned with the input signal at the PAs. The interconnect network between the supply modulator and the output of the PAs is designed to minimize inductance and capacitance in order to minimize filtering of the signal on the drain bias. (b) 3D view of the modular array showing the broadband Wilkinson feed network, PA assembly board with 4 MMIC PAs, interconnect bias network, microstrip-to-waveguide transitions to the radiators, and back view of a 4-element small-aperture dielectrically-loaded horn array. The modular approach allows characterization of the PAs with  $50\text{-}\Omega$  loads, as well as with the  $4 \times 1$  antenna array.

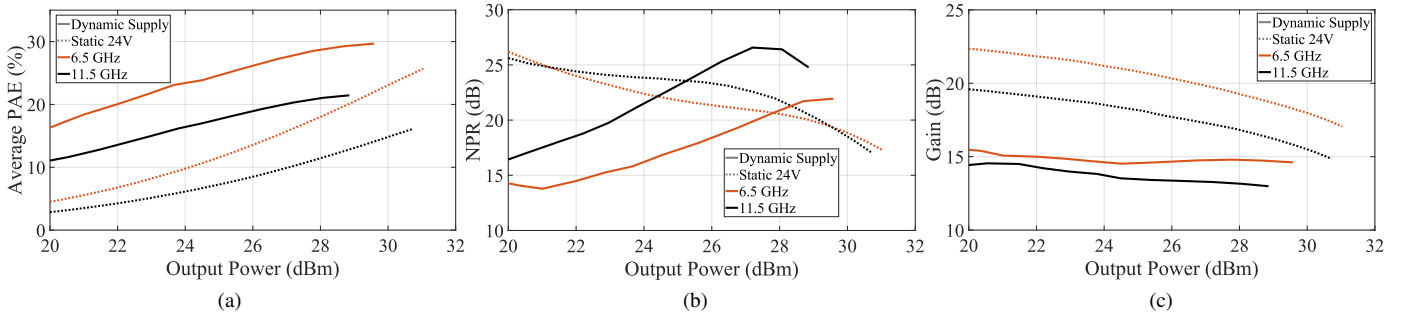

Fig. 2. Supply modulation results of a single device compared to results with a static drain voltage of 24 V at 6.5 and 11.5 GHz. (a) Average PAE; (b) NPR and (c) gain as a function of output power.

which often limits array performance. To the best of the authors' knowledge, this is the first demonstration of dynamic supply modulation for broadband array efficiency and linearity enhancement. High efficiencies have been obtained for single PA element high-power GaN transmitters using dynamic supplies for a range of carrier frequencies, for example in L-band (1.8 GHz) for communications [2], and in X-band (9.57 GHz) for radar applications [3]. However, applying a dynamic supply to multiple PA elements (e.g. an array) has not been experimentally demonstrated. In a front end, the PA typically feeds an antenna, and active arrays with a GaN PA per element are of interest for achieving high effective radiated power (ERP) through spatial power combining of the individual elements. Limited previous published work on supply modulation applied to arrays includes a theoretical investigation of the misalignment between the drain and input signal for each of the individual array elements [4]. In addition, non-linearities created by this type of misalignment are examined in [5] starting from single PA measurements and extrapolating theoretically to an array. In [6], linearization of a narrowband array under continuous supply modulation at 2.14 GHz with a 20 MHz LTE signal is presented, but the hardware description is not included as the paper focuses on the digital pre-distortion (DPD) algorithm.

Here we demonstrate a hardware implementation and characterization of a supply-modulated  $4 \times 1$  active transmit array with an operating bandwidth covering 6–12 GHz and 2 W GaN MMIC PAs feeding each antenna element (Fig. 1). First, supply modulation of a single PA loaded with  $50 \Omega$  is performed for a 10 MHz noise-like signal with PAPR=10.7 dB. These results are then compared to the case when 4 of the same PAs are fed with a broadband corporate feed network loaded with  $50 \Omega$  at all 4 output ports, and with a linear antenna array loading. The efficiency and linearity of the array are examined at 6.5 GHz using the same 10 MHz noise-like signal.

## II. SUPPLY MODULATION OF A SINGLE ELEMENT

The PA used in each element is a Qorvo TGA2598 GaN MMIC, with a nominal 2 W output power at 25 V drain bias, that operates from 6–12 GHz with a small signal gain ranging from 24.2 at 6 GHz to 21.1 dB at 12 GHz and a PAE of 43% to 28% over the same range at 25 V. The MMIC PA is mounted

on a copper-molybdenum (CuMo) carrier and the GSG pads are bonded to alumina  $50\text{-}\Omega$  microstrip lines with mechanical transitions to SMA connectors. The supply modulator is a 4-level GaN MMIC implemented in the Qorvo 150-nm GaN on SiC process and described in detail in [7]. This modulator is capable of providing greater than 30 W of dc power with high efficiency ( $>80\%$ ) while switching between voltage levels at 100 MHz.

The baseband signal is generated digitally using an arbitrary waveform generator then upconverted through a vector signal generator and amplified through a commercial driver before feeding the PA input. The supply modulator is controlled using a bit pattern generator which activates each discrete voltage level. The input signal is time aligned with the dynamic drain signal at the plane of the PA based upon the measured delay through the drain supply interconnect. The input and output spectrum are both measured using a vector signal analyzer. The relationship between the drain voltage and instantaneous envelope power is referred to as a shaping function and is determined from static CW PA characterization, described in more detail in [8]. The shaping function used in this setup is a compromise between maximum efficiency and overall flat gain across output power levels. Since gain decreases at lower drain voltages, the target flat gain with supply modulation must be lower than the gain at the highest voltage. The target gain is 15 dB, consistent with the measured gain shown in Fig 2c.

Figure 2a shows the measured average PAE for the 10-MHz noise-like signal at two carrier frequencies within the RF bandwidth, and for (1) a constant drain voltage of 24 V, and (2) with dynamic supply modulation varying the drain voltage between 10, 14.7, 19.3 and 24 V. In these plots, the efficiency of the supply modulator ( $>80\%$ ) is not taken into account, and only the PA efficiency is presented. The PA exhibits the highest efficiency at 6.5 GHz, and the lowest at 11.5 GHz, with the largest improvement of 8.2 percentage points at 6.5 GHz. The linearity is characterized using a multi-carrier white pseudo-random noise signal with a 5% notch at the center. The ratio of the average noise power to the average power inside the notch is called noise power ratio (NPR) and is shown in Fig. 2b. Supply modulation improves NPR for output powers exceeding 28 dBm and 25 dBm for the 6.5 GHz and 11.5 GHz cases, respectively. While supply modulation

improves efficiency and to some extent linearity, it lowers the gain, as shown in Fig. 2c. This drop in gain is expected from the chosen flat gain shaping function and results from the PA switching to lower drain voltages where decreased gains are observed.

### III. SUPPLY-MODULATED PA COMBINER

Referring to Fig. 1, the modulated input signal is split through a four-way 6–12 GHz 3-section Wilkinson divider and fed to the individual PAs. The drain signal is supplied to the four PAs simultaneously, using the same four-level discrete supply modulator as in Sec. II. We note that the drain signal is re-aligned at the PA input plane after implementing the array drain bias interconnect, which is modified from the single-PA case. A photograph of the prototype is shown in Fig. 3. The antenna array elements are double-ridge flared small-aperture horns designed for 6–12 GHz, described in more detail in [9]. The mechanical design of the array is modular in the  $z$ -direction (Fig. 1b), allowing the measurement of output power with  $50\ \Omega$  loads instead of the antennas. This is relevant since the broadband antennas couple at the lower part of the band, and it is of interest to evaluate the effect of the active reflection coefficient on supply-modulated PA efficiency.

To accurately measure the output power at the PAs, a power sampling network consisting of microstrip directional couplers is inserted in each of the elements at the output of the PAs, pictured in Fig. 3. The effect of the couplers is de-embedded, and the measurement reference plane is at the output of the PAs. The coupling factors of the power sensors are calibrated individually for each element by comparing the PA output power to the coupled power measurement. The loss in the samplers is measured with an identical separate board.

The biasing of the MMICs is accomplished through a co-designed network mounted perpendicularly to the array plane. The drain bias network is critical for supply modulation,

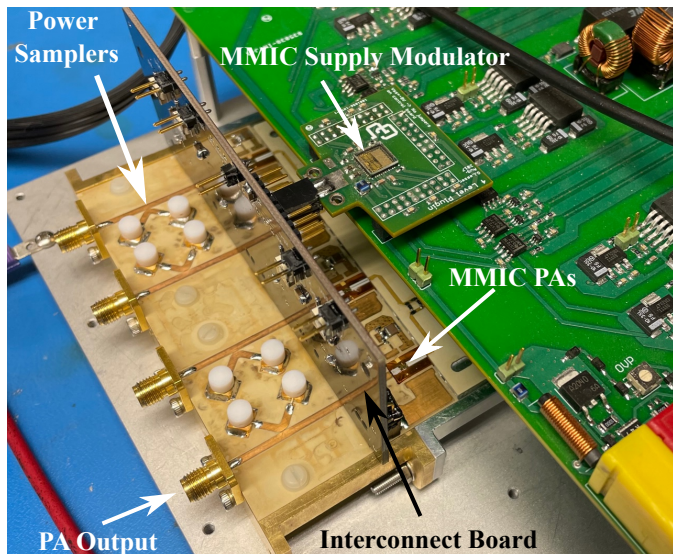

Fig. 3. Photograph of the array, not showing the antennas for clarity. The bias interconnect network is connected to the 4-level MMIC supply modulator in a QFN package. The calibration power sampler couplers are also shown.

TABLE I  
ACTIVE IMPEDANCES PRESENTED AT EACH PORT OF THE ARRAY

Freq. (GHz)	$Z_1$	$Z_2$	$Z_3$	$Z_4$
6.5	40.5+j8.5	38.5+j5.5	43+j21.0	49+j26.0

requiring minimal inductance and capacitance in order to behave as a low-pass filter with a cutoff frequency beyond the modulation bandwidth [2], [10]. Fig. 1b shows the low-inductance interconnect designed to minimize loading between the supply modulator and PA array.

Next, the PA array is characterized following the same procedure as for the single MMIC PA. First, the array is measured under CW excitation at 6.5 GHz, in order to evaluate the performance of the PAs integrated in the array. Fig. 4 displays the static characterization for drain voltages between 10 and 24 V at 6.5 GHz. These values are almost identical to the same measurements for a single PA (not shown here), indicating that the PAs in the array are functioning properly and the de-embedding through the coupler power samplers is accurate. The supply modulation results of the array at 6.5 GHz are presented in Fig. 5 and Fig. 6. The PAE, NPR, and gain of the array are shown in Fig. 5a–c with the modulated dynamic drain voltage compared to the static drain voltage case when the PAs are loaded with  $50\ \Omega$  where the loss in the supply modulator is de-embedded. Through supply modulation, the PAE and NPR is improved by 3.4,% and at least 2.5 dB at an output power of 33.6 dBm and frequency of 6.5 GHz.

The PA array is then loaded with antennas and the measurements are repeated. The impedances presented to the PAs are shown in Table I at 6.5 GHz, measured at the passive antenna ports with the coupler S-parameters cascaded and de-embedded to the outputs of the PAs. Fig. 6 a–c shows the results when the PAs are loaded with the antenna. When the PA array is loaded with antennas, a similar improvement in PAE and linearity is observed, while the overall efficiency is lower. Additionally, the NPRs of the individual PAs are different due to variations in the MMICs and input/output wire bonding. Likewise, the different load impedances presented to each port

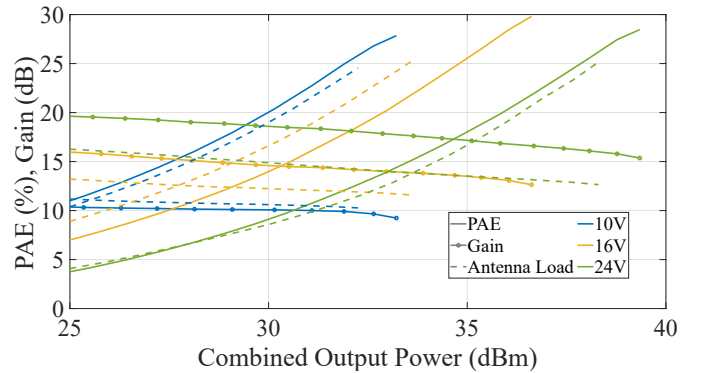

Fig. 4. Measured CW efficiency and gain for the array at 6.5 GHz with the four PAs loaded with  $50\ \Omega$  loads (solid) and with antenna elements (dotted). The PAE curves for different supply voltages are measured statically and averaged across the 4 PAs.

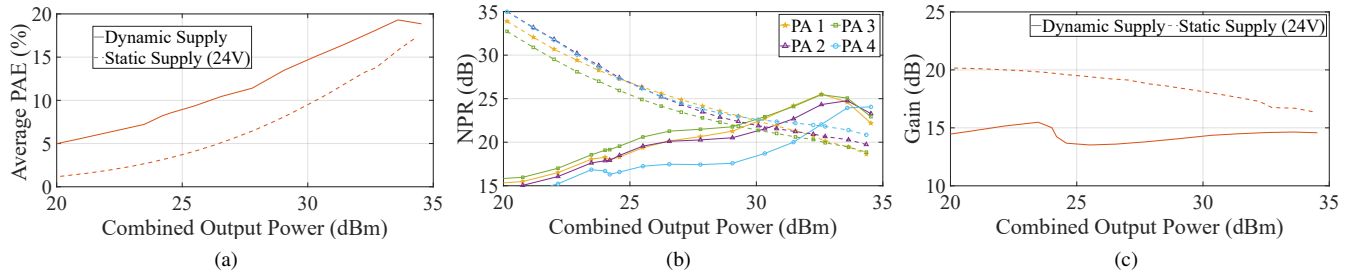

Fig. 5. (a) Average PAE, (b) NPR, and (c) gain of the 4 combined MMIC PAs with a constant supply voltage of 24 V compared to the supply-modulated case with 10, 14.7, 19.3 and 24 V discrete levels, with  $50\text{-}\Omega$  loads connected to each PA output.

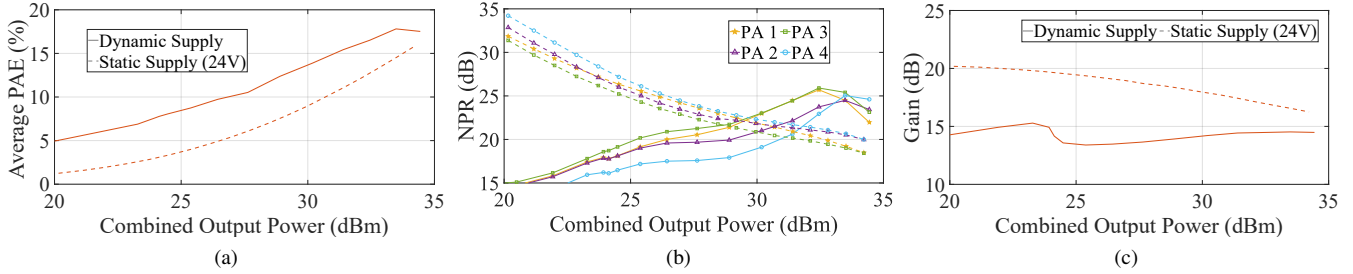

Fig. 6. (a) Average PAE, (b) NPR at 6.5 GHz, and (c) gain of the 4 combined MMIC PAs with a constant supply voltage of 24 V compared to the supply-modulated case with 10, 14.7, 19.3 and 24 V discrete levels, with **antenna loads** connected to each PA output.

by the antenna further affect the NPR of each individual PA.

#### IV. CONCLUSION

The hardware implementation and measurements of a 6 - 12 GHz active transmit  $4 \times 1$  array with dynamic supply modulation for a 10-MHz signal with a 10.7 dB PAPR is presented. The array drain bias voltage is generated from a single discrete four-level GaN MMIC supply modulator. The results are presented at 6.5 GHz when the 2-W GaN MMIC PAs are loaded with  $50\text{-}\Omega$  loads, and compared to loading with a 4-element small-aperture ridge horn array. The dynamic drain voltage measurements of the array are also compared with measurements taken on a single device. Overall the efficiency and linearity of the array are simultaneously improved through supply modulation. Furthermore, by minimizing the inductance and capacitance of the drain bias interconnect, the drain modulation signal is applied to each PA element without substantial filtering.

In an active transmit array, slowly varying the supply voltage between elements can be used to taper the beam, and [9] shows how nonlinearities in the array are affected by the supply voltage and antenna active reflection coefficient, and that it is difficult to maintain high efficiency across a wide bandwidth for modulated signals. Here we show that dynamic supply modulation is a possible solution for broadband array efficiency and linearity enhancement. A further extension of this work is the simultaneous transmission of multiple widely-spaced signals within the octave band.

#### REFERENCES

[1] B. Kim, J. Kim, D. Kim, J. Son, Y. Cho, J. Kim, and B. Park, "Push the envelope: Design concepts for envelope-tracking power amplifiers," *IEEE Microwave Magazine*, vol. 14, no. 3, pp. 68–81, 2013.

[2] N. Wolff, W. Heinrich, and O. Bengtsson, "Highly efficient 1.8-GHz amplifier with 120-MHz class-G supply modulation," *IEEE Transactions on Microwave Theory and Techniques*, vol. 65, no. 12, pp. 5223–5230, 2017.

[3] T. Cappello, C. Florian, D. Niessen, R. P. Paganelli, S. Schafer, and Z. Popovic, "Efficient X-band transmitter with integrated GaN power amplifier and supply modulator," *IEEE Transactions on Microwave Theory and Techniques*, vol. 67, no. 4, pp. 1601–1614, 2019.

[4] A. Zai, K. E. Kolodziej, M. Lockard, and J. S. Herd, "Shared Envelope Tracking for Time-Delayed Power Amplifiers in Phased Array Systems," in *2019 IEEE International Symposium on Phased Array System & Technology (PAST)*. IEEE, 2019, pp. 1–4.

[5] N. Wolff, W. Heinrich, and O. Bengtsson, "Class-G supply modulation for MIMO and radar with phased array antennas," in *2019 12th German Microwave Conference (GeMiC)*. IEEE, 2019, pp. 131–134.

[6] C. Yu and A. Zhu, "A single envelope modulator-based envelope-tracking structure for multiple-input and multiple-output wireless transmitters," *IEEE transactions on microwave theory and techniques*, vol. 60, no. 10, pp. 3317–3327, 2012.

[7] A. Sepahvand, P. Momenroodaki, Y. Zhang, Z. Popović, and D. Maksimović, "Monolithic multilevel GaN converter for envelope tracking in RF power amplifiers," in *2016 IEEE Energy Conversion Congress and Exposition (ECCE)*. IEEE, 2016, pp. 1–7.

[8] C. Nogales, Z. Popović, and G. Lasser, "A 10-W6-12GHz GaN MMIC Supply Modulated Power Amplifier," in *2022 52nd European Microwave Conference (EuMC)*. IEEE, 2022, pp. 436–439.

[9] L. Marzall, C. Nogales, S. Schafer, G. Lasser, and Z. Popović, "Nonlinear and Load-Pulling Effects in an Octave-Bandwidth Transmit Array," *IEEE Transactions on Microwave Theory and Techniques*, 2022.

[10] J. Hoversten, S. Schafer, M. Roberg, M. Norris, D. Maksimovic, and Z. Popovic, "Codesign of PA, supply, and signal processing for linear supply-modulated RF transmitters," *IEEE Transactions on Microwave Theory and Techniques*, vol. 60, no. 6, pp. 2010–2020, 2012.