



CHALMERS
UNIVERSITY OF TECHNOLOGY

Negative CO₂ emission from oxy-fuel combustion in CFB boilers

Downloaded from: <https://research.chalmers.se>, 2026-04-04 18:50 UTC

Citation for the original published paper (version of record):

Leckner, B. (2023). Negative CO₂ emission from oxy-fuel combustion in CFB boilers. *Fuel*, 333. <http://dx.doi.org/10.1016/j.fuel.2022.126425>

N.B. When citing this work, cite the original published paper.



Negative CO₂ emission from oxy-fuel combustion in CFB boilers

Bo Leckner

Division of Energy Technology, Chalmers University of Technology, 41296 Göteborg, Sweden

ARTICLE INFO

Keywords:

Oxy-combustion
Circulating fluidized bed
Boiler
Biomass
CO₂ reduction

ABSTRACT

Oxy-combustion by flue-gas recirculation for CO₂ capture is applied to an existing, already CO₂-neutral, biomass-fired circulating fluidized bed (CFB) boiler, thus resulting in negative CO₂ emissions. The required oxygen concentration is determined by a heat balance, but in an existing plant the volume flow is then reduced as well as the fluidization velocity, which affects the heat transfer. Methods to resolve this problem are investigated. The oxygen is usually proposed to be supplied by air separation; a method that consumes a considerable share of the energy produced in the plant. Here, it is instead suggested to use oxygen produced together with hydrogen in electrolysis by excess wind and solar power.

1. Introduction

The emission of CO₂ from renewable biomass is assumed not to contribute to the global warming if it is replaced by the growth of new biomass. It is then considered CO₂-neutral. If this CO₂ emission is captured and disposed of, the resulting emission from a combustion plant can be counted as negative. CO₂ capture from combustion in fluidized bed can preferably be carried out through oxy-combustion in such a way as has been proposed for coal-fired plants. In the present work the retrofit to oxy-combustion of a typical biomass and of a typical bituminous coal circulating fluidized bed (CFB) plant are compared to illustrate the behaviour of biomass in this application compared to coal. Of course, the emission from the coal-fired plant is, if captured, not negative. Attention is focused on the rebuilding of existing CFB boilers to oxy-firing. The boilers, originally designed for air-combustion with biomass or with coal, should be modified without changing their power, fuel, or operation conditions, which is a more challenging task than the design of new oxy-fuel boilers whose dimensions can be fitted to the volume flow of oxy-combustion. Such a study for coal combustion has been carried out recently [1], and the present analysis just applies that study to biomass. The purpose of the present work is to analyze the consequences of CO₂ capture from biomass by oxy-combustion in existing CFB plants, operated with biomass, and to compare with previous experiences from modelling of a coal combustion plant.

2. The oxy-fuel arrangement

Oxy-fuel combustion means that combustion takes place without air-nitrogen, to simplify the treatment (compression) of the resulting CO₂ from the flue gas after condensation of the water vapour, formed together with CO₂ during combustion or from fuel moisture. This is done

by combustion in oxygen from air separation or from some other source to be discussed below. The combustion oxygen is diluted to correspond thermally to the gas produced by combustion in air. In this case the dilution is carried out by recirculated flue gas (Fig. 1b), or by steam (Fig. 1c), compared with the air-combustion case in Fig. 1a.

As indicated in Fig. 1b, the circulated flue gas may be wet or dry if most water is removed by condensation. The difference between the two options is small [2]. Condensation and related low-temperature corrosion may take place if the water and sulphur concentrations are high. However, this can be avoided by maintaining the temperature above the acid dew point, something that is not too complicated, considering the low sulphur content in biomass.

The alternative system, Fig. 1c, water addition, has many advantages, such as pressurization in the water phase before steam production to overcome the many pressure-drops in the CFB gas pass, in distributor, bed, cyclone, and heat-exchanger tube bundles. The drawback is that a considerable amount of low-temperature heat is needed to evaporate the water at a pressure of a few bars. Then the similar amount of heat is lost in the flue-gas exit at a low temperature, where it can hardly be utilized, except, possibly, in a low-temperature district-heating system. In a new system to be designed, pressurization of the entire plant could be discussed as a solution, but this is not feasible in an existing plant. Because of the limitations mentioned, the water-injection option is not further treated here.

3. Fuel, media data, and operation conditions

A common coal and a typical biomass are selected for the analysis, Table 1.

The operation conditions are given in Table 2, chosen to be as typical as possible. Table 3 shows the properties of the media involved.

<https://doi.org/10.1016/j.fuel.2022.126425>

Received 17 June 2022; Received in revised form 12 September 2022; Accepted 18 October 2022

Available online 22 October 2022

0016-2361/© 2022 The Author(s). Published by Elsevier Ltd. This is an open access article under the CC BY license (<http://creativecommons.org/licenses/by/4.0/>).

Nomenclature		w	Moisture content in fuel, kg/kg fuel
<i>Symbols and acronyms</i>		<i>Greek symbols</i>	
A	Surface area, m ²	Δ	Difference
a	Ash content in fuel, kg/kg fuel	λ	Stoichiometric oxygen ratio, -;
b	Combustibles in fuel, kg/kg fuel	ρ	Density, kg/m ³
CFB	Circulating fluidized bed	<i>Indices</i>	
c	Carbon content in fuel, kg/kg combustibles	<i>air</i>	Air-combustion
c_p	Specific heat at constant pressure, kJ/kg,K	<i>f</i>	Furnace
$f()$	Heat transfer coefficient, kW/m ² K, dependent on average particle density $\bar{\rho}_s$ and T_f .	<i>g</i>	Gas
F	Fuel, kg combustible/s	<i>heat</i>	heat transfer
FB	Fluidized bed	<i>in</i>	Entering
g	Gas amount, kg/kg combustibles; Index v , m ³ /kg combustibles	<i>int</i>	Internal in furnace
H	Heating value, kJ/kg combustibles	<i>LHV</i>	Lower heating value
h	Hydrogen content in fuel, kg/kg combustibles	<i>o</i>	Initial, outside
ℓ	Stoichiometric amount of oxygen, kg/kg combustibles	<i>ox</i>	Oxy-combustion
M	Molecular mass, kg/kmol	<i>out</i>	Exiting
o	Oxygen content in fuel, kg/kg combustibles	<i>part</i>	particle
Q	Heat power, kW/kg combustible	<i>pm</i>	Index in c_{pm} denoting mean c_p over a temperature range
T	Temperature, K or °C	<i>r, rec</i>	Recycle
\underline{u}	Fluidization velocity, m/s	<i>v</i>	Volume
		<i>w</i>	Wall

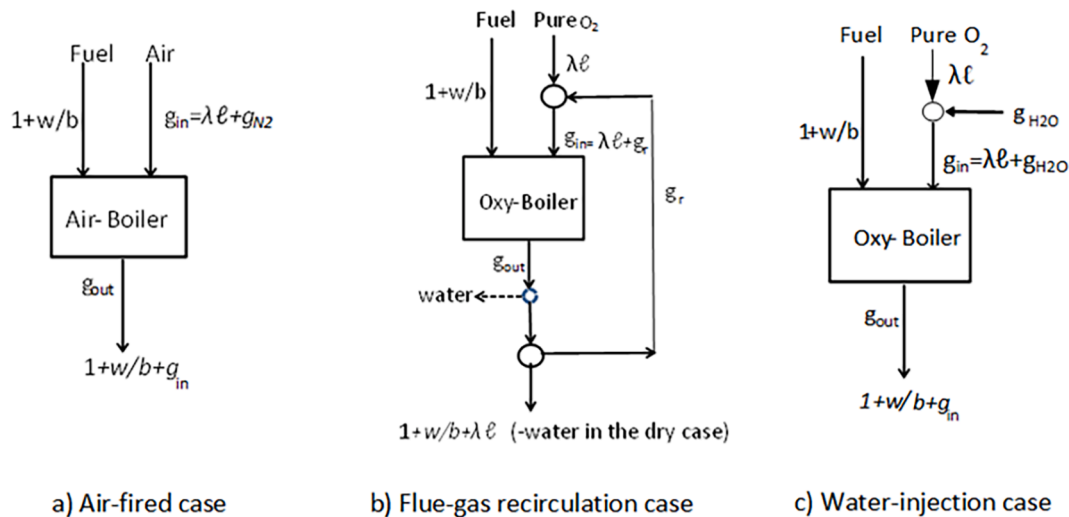

Fig. 1. Three alternative arrangements. a) air combustion b) flue-gas recirculation c) H₂O injection. The calculations are carried out for the fuel feed of $F = 1$ kg/s combustible matter. Symbols: b kg combustibles/kg fuel, g kg gas/kg combustibles, ℓ kg O₂/kg combustibles, w - kg moisture/kg fuel, λ - excess-oxygen ratio. Indices: in - entering the furnace, out - exiting the furnace, r - recirculation of gas, H₂O - water addition, N₂ - nitrogen addition (with air).

4. Balances

Table 3 shows that the media properties of N₂ in air are different from those of CO₂ and H₂O in the recirculated flue gas, which replaces the N₂. To maintain the thermal load as well as the heat balance of the furnace constant, the oxygen concentration must be adjusted from its mass concentration of 0.23 in air to a value that satisfies the heat balance. This is usually done (in pulverized fuel combustion) by a simple heat balance over the furnace.

The heat balance for the air and the oxy-combustion cases in a CFB furnace can be written (the same formulation, but with different input data, is valid both for wood and coal, wet or dry).

$$\begin{aligned}
 F_{air}H_{LHV} &= Q_{int,air} + F_{air}g_{air,out}c_{pm,air}\Delta T_f \\
 F_{ox}H_{LHV} &= Q_{int,ox} + F_{ox}g_{ox,out}c_{pm,ox}\Delta T_f
 \end{aligned}
 \tag{1}$$

here, the input heat, the fuel-feed rate F times the lower heating value H_{LHV} , is spent on the internal heat extraction Q_{int} , and on heating of the gas from its entry at $T_{in} = 150$ °C to its exit from the furnace at the furnace temperature of $T_f = 850$ °C, expressed as ΔT_f . The heating of the fuel to the inlet level is neglected. Then, with F , Q , and ΔT_f constant, Eq. (1) gives,

$$g_{air,out}c_{pm,air} = g_{ox,out}c_{pm,ox}
 \tag{2}$$

where the input oxygen concentration is hidden in the gas yield g , calculated according to the stoichiometry and excess oxygen, given by the data in Tables 1 and 2 and the standard expressions presented in Ref [1]. c_{pm} is the mean specific heat of the gas found in Table 3.

Some further comments are necessary.

The circulating particles do not contribute to the overall heat balance

Table 1
Fuels.

Proximate analysis, kg/kg fuel		
Combustibles, <i>b</i>	Wood	Bituminous coal
Ashes, <i>a</i>	0.79	0.80
Moisture, <i>w</i>	0.01	0.10
Moisture, <i>w</i>	0.20	0.10
Ultimate analysis, kg/kg combustibles		
Carbon, <i>c</i>	Wood	Bituminous coal
Hydrogen, <i>h</i>	0.50	0.85
Oxygen, <i>o</i>	0.06	0.05
Oxygen, <i>o</i>	0.44	0.10
Other data, kg/kg combustibles		
Heating value, <i>H</i> kJ/kg	Wood	Bituminous Coal
Volatile content, kg/kg	19,000	28,000
Specific flue-gas yield, g kg/kg	0.85	0.30
<i>H/g</i> @10% excess oxygen	7.82	13.40
	2430	2090

Table 2
Operation conditions.

Condition	Value
Bed temperature, (constant in the furnace)	850 °C
Recirculation gas temperature	150 °C
Fluidization velocity	5 m/s
Primary/secondary air	50/50
Oxygen stoichiometric ratio	1.1
External heat exchanger	none
The dimensions of the boiler	same as with air

Table 3
Media data.

Quantity	Density ρ kg/m ³		Specific heat c_p , kJ/kg.K ^a			<i>M</i> , molecular mass kg/kmol
	0 °C	850 °C	0 °C	850 °C	150–850 °C ^b	
Air	1.273	0.310	1.007	1.163	1.091	28.9
N ₂	1.233	0.300	1.038	1.187	1.116	28.0
O ₂	1.410	0.343	0.909	1.103	1.039	32.0
CO ₂	1.938	0.471	0.848	1.261	1.142	44.0
H ₂ O	0.793	0.193	1.864	2.385	2.137	18.0
Solids	–	–	–	–	1.2	–

^a Calculated by EES [31], which uses the JANAF database.

^b Calculated by integration between 150 and 850 °C.

if there is no external heat-exchanger affecting the particle temperature. The particles are simply a means of heat transport from the heat release by the fuel to the heat receiving surfaces in the furnace. Moreover, they serve as a “thermal flywheel” to even out minor temperature fluctuations in the gas-particle suspension.

The internal heat transfer requires further attention. It can be written,

Table 4
Results of the furnace heat balance.

Operational condition	Gas density, @ 850 °C kg/m ³	Gas spec. heat, kJ/kg.K	Gas composition, % mass				Input oxygen, mass %	Fluidization velocity, m/s
			O ₂	CO ₂	H ₂ O	N ₂		
WOOD								
Air combustion	0.31	1.22	2	23	10	64	23	5.0
Oxy-circulation, wet	0.33	1.42	5	66	29	0	30	4.0
Oxy-circulation, dry	0.46	1.13	7	93	0	0	27	3.6
BITUMINOUS COAL								
Air combustion	0.32	1.16	2	23	4	71	23	5.0
Oxy-circulation, wet	0.38	1.31	6	77	17	0	31	3.8
Oxy-circulation, dry	0.46	1.13	7	93	0	0	25	3.8

$$Q_{int} = f(\bar{\rho}_{part}, T_f) A_{int,heat} \Delta T_{fw} \quad (3)$$

where ΔT_{fw} is the temperature difference between the (constant) furnace temperature T_f and the (constant) average temperature of the heat-receiving surface. In Eq. (3), $A_{int,heat}$ is the (constant) area of the heat-receiving surface. The heat transfer coefficient $f(\bar{\rho}_{part}, T_f)$ depends on the average suspension density $\bar{\rho}_{part}$ in front of the heat-transfer surface. This quantity is a function of the fluidization velocity but is provisionally regarded constant during the transition from air to oxy-combustion, awaiting a separate discussion below. The results are presented in Table 4.

Table 4 shows that the required input oxygen (mass) concentration is about 30% and a little less in the dry case. The gas compositions in the coal and biomass cases are quite similar. In both flue-gas circulation cases the excess-oxygen concentration in the furnace is considerably higher than in the air case. This is due to the gas recirculation, as has been explained previously [2]. The differences between coal and wood (wood has higher volatile content and lower heating value) play a role for the design of the respective boilers, but it is not important in the present comparison between air and oxy-firing in the two boilers, designed for either coal or for biomass. However, the fluidization velocities are less than that in the air case, and, for that reason, the assumption of a constant heat transfer is not valid because the particle density, affecting heat transfer, depends on the fluidization velocity.

The reason for the lack of agreement of the fluidization velocities is that the volume flows are different (the gas densities are different, see Table 3) even though the mass balance is the same: the flow of combustion gases ($F \bullet g$ kg/s) is equal to the flow represented by the fluidization velocity u ($u \bullet A_r$ m³/s), expressed as volume flows.

$$\begin{aligned} u_{air} A_r &= F_{air} g_{air,out} / \rho_{air} \Rightarrow u_{ox} \neq u_{air} \\ u_{ox} A_r &= F_{ox} g_{ox,out} / \rho_{ox} \end{aligned} \quad (4)$$

A_r is the furnace cross-section and ρ the gas density at furnace temperature in the air and oxy cases.

5. Remedies

The volume flow of gas is increased to give $u_{ox} = u_{air}$. Now, the heat transfer approximation introduced in the above mass balance is removed and the heat transfer coefficient related to the internal heat exchangers is,

$$f(\bar{\rho}_{part,ox} T_f) = f(\bar{\rho}_{part,air} T_f) \quad (5)$$

and so, $Q_{int,ox} = Q_{int,air}$. As before, the operation conditions of the boiler should be the same. This means that also the furnace temperature and the total excess-oxygen ratio are maintained constant. There are two options:

Option 1: The velocities are made equal by increasing the flue-gas recirculation while maintaining the oxygen concentration in the input gas constant. This supplies more oxygen to the furnace, which must be

Table 5
Results for $u_{ox} = u_{air}$.

Operational condition	Heat to furnace, Q_{int} kW/kg	Gas heating, kW/kg	Adjustment heat, kW/kg for $u_{ox} = u_{air}$	Fuel feed: Adjustment for $u_{ox} = u_{air}$	Fluidization velocity, u m/s
WOOD					
Air combustion	12,300	6700	0	1.0	5.00
Oxy-circulation, wet	12,300	6700	1600	1.08	4.0 → 5.0
Oxy-circulation, dry	12,300	6700	2500	1.13	3.6 → 5.0
BITUMINOUS COAL					
Air combustion	17,000	11,000	0	1.0	5.00
Oxy-circulation, wet	17,000	11,000	3400	1.12	3.8 → 5.0
Oxy-circulation, dry	17,000	11,000	4300	1.15	3.8 → 5.0

compensated by increasing the fuel feed to maintain constant the oxygen excess. In this case the heat balance, Eq. (1), yields,

$$\left(\frac{F_{ox}}{F_{air}} - 1\right) = g_{air,out,v} \Delta T_f (\rho_{ox} c_{pm,ox} - \rho_{air} c_{pm,air}) H_{LHV} \quad (6)$$

This is a breach of the condition of constant load and must be avoided.

Option 2. The flue-gas recirculation is increased just as in Option 1 but the input oxygen concentration is reduced to maintain constant the fuel feed, the furnace temperature, and the oxygen excess. Therefore, more gas passes the furnace at constant load. Then, the furnace temperature would fall because more gas must be heated. To compensate for this tendency, some heat transfer surface $A_{int,heat}$ could be removed or covered to reduce the heat extraction $Q_{int,ox}$. Equation (1) becomes,

$$-\frac{Q_{int,ox} - Q_{int,air}}{F_{air}} = g_{air,out,v} \Delta T_f (\rho_{ox} c_{pm,ox} - \rho_{air} c_{pm,air}) \quad (7)$$

The heat removed by the gas in this way is transferred to the back pass where it should be taken care of by the back-pass heat exchangers. Neglecting the difference in the media properties ρ and c_p , Eqs (6) and (7) show the equivalence between the two measures from a thermal point of view,

$$(F_{ox} - F_{air})/H_{LHV} \approx Q_{int,air} - Q_{int,ox} \quad (8)$$

A summary of results for the constant input oxygen concentration and $u_{ox} = u_{air}$ with fuel properties from Table 1 is shown in Table 5.

The table shows how the input fuel power is divided between the heat transfer surfaces and the heating of the gas. It also shows that an excess of 8 to 13% of the given power is either added or is transferred to be handled by the back pass in the case of wood and 12 to 15% in the case of coal. The backpass consists of various heat exchangers, such as evaporators, superheaters, reheaters, and feed-water heaters. The presence and size of these heat-transfer surfaces vary from boiler to boiler as a consequence of the design, considering fuel properties (risk for corrosion), steam data (steam pressure and temperature, giving the ratio of evaporation to superheating, reheating, feed-water heating and economizer performance). In general, the heat exchangers consist of tube bundles, for which heat-transfer relationships are available. Their performance during exposure to flue gases of different composition can then be estimated for one case (air combustion) relative to another (oxy-fuel combustion) in a generic heat exchanger. Such an analysis was carried out in Ref. [1], showing that backpass heat-exchangers can swallow the changes in heat supply mentioned above because of the improvement in the convective heat transfer caused by the difference in the thermal properties of the gas after a change from air to oxy-firing. It was shown that even some excess heat transfer could be expected in the oxy-fuel case, and some heat transfer surfaces in the backpass may have to be covered or removed. In a detailed analysis, the heat transferred must be correctly distributed to the various tasks of the heat exchangers, but this is difficult to present here in a generalized way, as it depends on the thermal conditions of each specific boiler, caused by fuel and steam

data.

6. Conclusions and comments

In addition to the arrangements for oxygen supply and CO₂ handling, the conversion of an air-fired CFB boiler to oxy-combustion seems quite uncomplicated: it consists of a flue-gas duct from the exit of the gas filter to the wind box of the boiler together with necessary fans and related equipment. It is similar for coal and biomass. To avoid ingress of air the furnace and the gas ducts should be tightened.

It is possible to satisfy the heat and mass balance after the change, but the volume flow is reduced, and then also the fluidization velocity. This can be remedied in various ways, for instance by increasing the recirculation flow to reach the same fluidization velocity as in air combustion at the given temperature. Then, with the larger gas flow, more heat is removed from the combustion chamber and transferred to the back pass. Furthermore, to compensate for the increased heat removal with the gas, some minor modifications are required: the heat-receiving surface of the furnace should be reduced by about 10% and the corresponding heat is transferred instead in the back pass. There are several arrangements of back-pass heat exchangers and related steam data, so it is difficult to predict in general how to arrange the additional heat uptake. A generalized analysis shows, however, that the change from air to oxy-firing enhances the convective heat transfer, and this facilitates the conversion of the back pass to oxy-combustion. These conclusions and the following discussion are also valid for coal combustion.

The major drawback of oxy-combustion is the high energy consumption for air separation. However, one could pay attention to some remedies:

- 1) The air separation may consume about 6–10% efficiency units from a power plant [4]. With a net efficiency for electricity production of about 40% this is up to 20% of the output from the plant. If heat and electric power are evaluated as equal, this quantity would be less than about 10% in a heat and power plant or in a heating plant.
- 2) The recent development of energy systems is relying on the supply of energy from wind and solar sources. These sources do not follow the energy demand, and if their coverage of the demand is considerable, the result is inevitably a great excess of energy and both a short-term storage (day-night) and a long-term storage (seasonal) of solar energy is of interest. The need for energy storage is obvious, and one of the most attractive options would be hydrogen energy (or similar, such as ammonia for storage) produced by electrolysis of water. In addition to that, certain enterprises consider utilizing hydrogen in their processes. For example, Swedish industries involved in the production of iron are planning to use hydrogen instead of coal (“Hybrit”). Since the idea is to produce “green” hydrogen avoiding fossil fuels (including fossil gas), electrolysis of water seems to be the given candidate, hoping that utilization and technical development will reduce the cost of such processes.

According to the stoichiometry, $H_2O = H_2 + \frac{1}{2}O_2$. Theoretically, the production of 1 kg H_2 yields 8 kg O_2 . Although there is a demand for oxygen in the society, it is likely that there will be an excess of oxygen production. Or, expressed from the other side: The use of oxygen for oxy-combustion reduces the excess of oxygen that most likely results from a high demand for hydrogen.

The present work discusses the conversion of existing plants to oxy-combustion but building of new plants for oxy-combustion is also an option, which is even simpler than retrofitting existing plants. Furthermore, it should be emphasized that FB boilers are quite suitable for the purpose.

Funding

This research did not receive any specific grant from funding agencies in the public, commercial, or not-for-profit sectors.

Declaration of Competing Interest

The author declares that he has no known competing financial interests or personal relationships that could have appeared to influence the work reported in this paper.

Data availability

No data was used for the research described in the article.

References

- [1] Leckner B, Gómez Barea A. Change of existing circulating fluidized bed boilers to oxy-firing conditions for CO₂ capture. *Appl Energy Combust Sci* 2021;8:100042.
- [2] Leckner B, Gómez Barea A. Oxy-fuel combustion in circulating fluidized bed boilers. *Appl Energy* 2014;125:308–18.
- [3] <http://www.fchart.com/ees/> (accessed 2021.04.30).
- [4] Kotowicz J, Michalski S, Brzeczek M. The characteristics of a modern oxy-fuel power plant. *Energies* 2019;12:3374.