



CHALMERS
UNIVERSITY OF TECHNOLOGY

Impacts of Fast Charging of Electric Buses on Electrical Distribution Systems

Downloaded from: <https://research.chalmers.se>, 2026-04-06 12:53 UTC

Citation for the original published paper (version of record):

Steen, D., Le, A. (2017). Impacts of Fast Charging of Electric Buses on Electrical Distribution Systems. *CIREN - Open Access Proceedings Journal*, 2017(1): 2350-2353.
<http://dx.doi.org/10.1049/oap-cired.2017.0802>

N.B. When citing this work, cite the original published paper.

Impacts of fast charging of electric buses on electrical distribution systems

David Steen , Le Anh Tuan

Chalmers University of Technology, Gothenburg, Sweden

 E-mail: david.steen@chalmers.se

Abstract: Electric buses have gained a large public interest lately. In Gothenburg, Sweden, a demonstration project is currently underway where electrical and hybrid electric buses are being tried. This study investigates the impacts on the electrical distribution system from the fast-charging stations used to power the electric buses. Alternatives to mitigate the impacts including demand response (DR) and energy storage at the charge location have also been investigated in the study. A case study has been performed for the distribution system of Chalmers University of Technology where a charging station is located. The study results show that in all of the simulated areas, the grid could handle a 300 kW charge station without any problems. Energy storage and DR could, to some extent, support the grid to manage the fast-charging stations but would be limited by the utilisation factor of the charger.

1 Introduction

Electric buses are being considered an attractive alternative to reduce global CO₂ emissions as well as local pollution and noise in modern cities [1]. They have lately gained increasing attention recently by various stakeholders, including city authority, bus manufacturers, and distribution network companies. Compared with the conventional bus, the electric bus uses electricity for propulsion and needs to be charged from the electrical grid. Currently, there are three main alternative designs of the bus/charge system, including overnight charging, opportunity charging, and flash charging [2, 3]. The overnight charging is used for buses with large batteries that could cover the fully daily distance and mainly charge during the night when the bus is parked. Flash charging refers to charging at the bus stops at a high-power level. This system requires less energy to be stored in the bus, but on the other hand, a more expensive charge infrastructure. The opportunity charging can be seen as something in between, the buses are being charged during normal pauses in the time table, e.g. at the end stops. This requires less expensive infrastructure but larger batteries compared with the flash charging [2].

Owing to the high requirements on electric energy, electric buses could have a substantial impact on the electrical distribution system [3–6]. In [3], the impact was found to be less severe for overnight charging compared with the other two alternatives, mainly due to the lower power requirements and the lower electricity demand during night time. The high-power requirement and short charge time for flash and opportunity charging will result in an uneven charge profile for the charge station [3]. Even by considering a number of chargers covering several bus routes, the instantaneous peak demand could be substantially higher than the hourly average demand [5, 6]. To decrease the grid impact of the charger, the charge station could be equipped with an energy storage system (ESS) [2]. In [4], the value of adding an energy storage was investigated for a fast-charging station. The results indicate that from a cost perspective, it could be beneficial to invest in an ESS.

In Sweden, a project called ‘Electricity’ is currently underway where a new bus line in Gothenburg is operated using electric and plug-in hybrid electric buses [7]. The project aims to demonstrate and evaluate the potential benefits with electric public transportation such as indoor bus stations, but will also serve as a platform to test and verify new research concepts.

This paper will present measurements from an existing fast-charging station located at the campus of Chalmers University.

The measurements are used to estimate the impact on different parts of the local distribution grid. Furthermore, alternatives to reduce the impact have been investigated, including ESS and demand response (DR).

The paper is organised as follows: Section 2 presents the data and assumptions used in the study. Section 3 presents the approach and simulation model. In Section 4, the results are presented and the conclusions are presented in Section 5.

2 Methodology

The study consists of two parts, one part covering the measurement of the charging and the resulting impact on the connected distribution system and one part covering the possibilities to reduce the impact by using ESS and DR. The flowchart of the study approach is presented in Fig. 1.

The grid impact was assessed by simulations in an optimal power flow based model using General Algebraic Modeling System (GAMS) [8]. The model includes a module that optimally schedules customers’ flexible loads which is utilised in the case with DR. The model is further described in [9]. To enable the possibility to include an ESS, the model was extended with an energy storage module considering the state of charge of the batteries.

To analyse the grid impact of one charge station and the possible benefits of utilising active strategies, the objective function of the model was set to minimise the grid losses. In addition, the model could be used in order to find the maximum charge power that could be extracted at different locations.

3 Case set-up and data

This section presents the data and assumption used in the study.

3.1 Electric bus data and measurement

The electric bus line investigated in this study was put in operation in 2016 connecting the two campuses of Chalmers University of Technology. The route is ~10 km long and takes ~25 min and there is one departure every 10 min. It is operated by three fully electrical buses and seven hybrid electric buses, all developed by

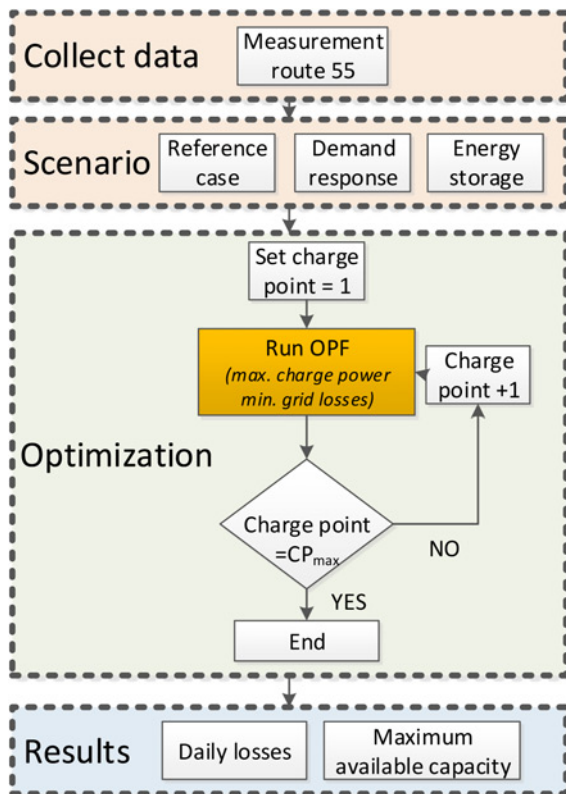

Fig. 1 Flowchart of the proposed approach

Volvo buses [7]. The charging is conducted at each end stop with a charge power of up to 300 kW. The charge station is provided by Siemens and is based on conductive power transfer through a pantograph system. Electrically, the charge stations are connected to the 10 kV distribution system through an existing 10/0.4 kV transformer by two parallel 240 mm² cables.

The measurements were conducted during November 2016–January 2017 using a measurement system that measured the energy consumption with a time resolution of 6 s [10]. The measurements were used to evaluate the impacts on the distribution system and to analyse alternatives to reduce the impacts.

3.2 Grid data

One of the fast-charging stations is located at the Johanneberg Campus of Chalmers University Technology.

The area consists mostly of office buildings, lecture halls, and laboratory facilities. Fig. 2 presents a one-line diagram of the 10 kV distribution system. The system is designed as a meshed distribution system but is normally operated radially. The charge station is located at bus 28. To assess the worst-case condition, the simulations were conducted for the day with highest demand.

For investigating the possible impacts of fast charging in other areas and to assess the potential to reduce the impacts by using DR or ESS, a residential area in Gothenburg was chosen. The grid consists of 26 10/0.4 kV transformers connected through 3 main feeders. A detailed description of the grid can be obtained in [11]. As for the campus area, the charge impact was assessed for the peak day of the area.

For the case with DR, only electric heating was considered as schedulable and the temperature variations were limited to ±1.5°C. The responsive customers were assumed to be 10% and evenly distributed within the grid.

For the case with ESS at the charge location, the charge/discharge profile was decided by the optimisation model with the objective set to minimise the losses in the system. Simulations were conducted with a usable capacity of the ESS of 5% of the charge station

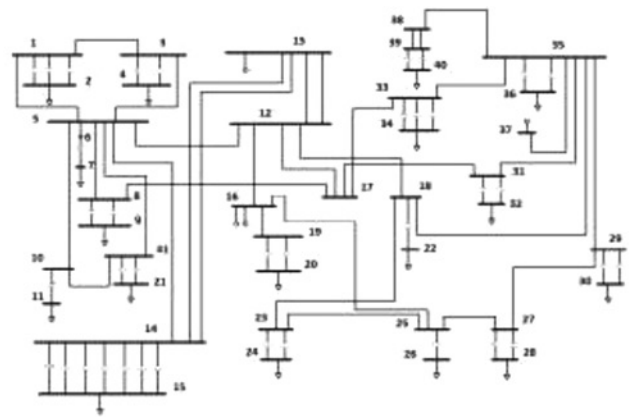

Fig. 2 One-line diagram of the distribution system in the Campus Johanneberg of Chalmers University of Technology

capacity and with a limit on the charge rate at 5C (of the usable capacity).

3.3 Energy storage system

The possible impact of the ESS will mainly depend on the size of the storage and the charge time in relation to the time between the buses. For a single charge point, the power drawn from the grid could be calculated from

$$P_{\text{Grid}} = \begin{cases} P_{\text{ch}} - \frac{E_{\text{ESS}}}{T_{\text{C}}} & \text{if } E_{\text{ESS}} < E_{\text{bus}} * \left(1 - \frac{T_{\text{C}}}{T_{\text{B}}}\right) \\ \frac{E_{\text{bus}}}{T_{\text{B}}} & \text{if } E_{\text{ESS}} > E_{\text{bus}} * \left(1 - \frac{T_{\text{C}}}{T_{\text{B}}}\right) \end{cases} \quad (1)$$

where P_{Ch} is the charge power, E_{ESS} the usable capacity of the storage, E_{bus} the energy required by the bus, T_{C} the charge time, and T_{B} the time between the buses.

As can be derived from (1), for large ESS or for charge stations with a low utilisation, i.e. long time between the buses or short charging times, the potential reduction to the grid is limited by the energy required by the bus and the time between the buses, e.g. the average power demand. For smaller ESS, the possibility to shift large amount of energy is limited, or if the charge station has a high utilisation, the average charge power is high; hence, the possible load reduction is limited by the storage size and the charge time.

4 Results and discussions

This section presents the results from the study.

4.1 Energy measurement

Figs. 3 and 4 present the charge power during 1 day in January and for two charge cycles. As can be seen, the charge power varies between ~100 and 240 kW, where the hybrid buses are being charged with 100 kW and the fully electric buses with 240 kW. One of the reasons for this could be due to that the battery in the hybrid bus is designed for lower current levels and charging with higher power would reduce the lifetime of the battery. The charge time for the electric bus is ~2 min, while it varies for the hybrid bus but is generally around 3 min.

4.2 Energy storage system

Fig. 5 presents the grid power drawn from a 300 kW charge station with different storage sizes for four different utilisation factors of the

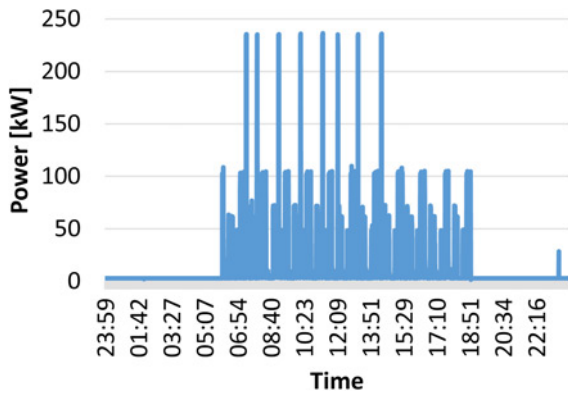

Fig. 3 Load profile from one of the bus charging station in Gothenburg, 9 January 2017

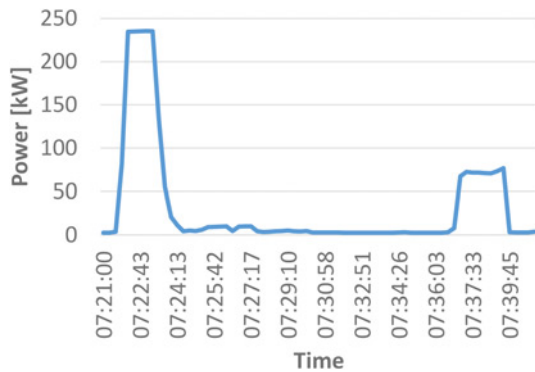

Fig. 4 Load profile for two charge cycles, 9 January 2017

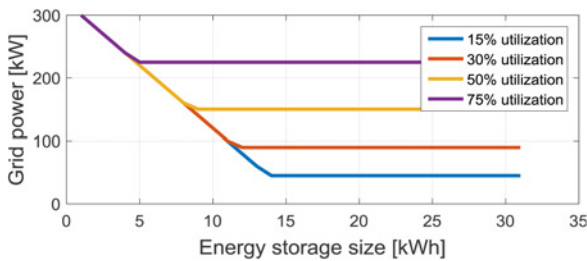

Fig. 5 Reduction in power drawn from the grid with 300 kW charger for different utilisation factors and energy storage sizes

charger, for the case with an energy consumption of 15 kWh between the charge stations. As can be seen, even with a small ESS, the power could be reduced substantially. However, it is important to remember that although the energy content is low, the actual size may be limited by the charge rate of the ESS if e.g. batteries are used. Similarly, due to the high number of cycles, it could be beneficial to limit the depth of the charge cycles to prolong the life of the ESS.

4.3 Chalmers campus

The simulations from the Chalmers Grid and the real bus charging station show that the impact on the distribution system is limited and the peak demand increase by only ~1%, as can be seen in Fig. 6.

Similarly, the voltage levels remain within limits and the changes in voltage due to the bus charging are minor. The lowest voltage level reaches 0.98 pu. Regarding the losses, there is a negligible impact on the losses due to the charging, this is mainly due to the small increase in the system load and due to that the distribution

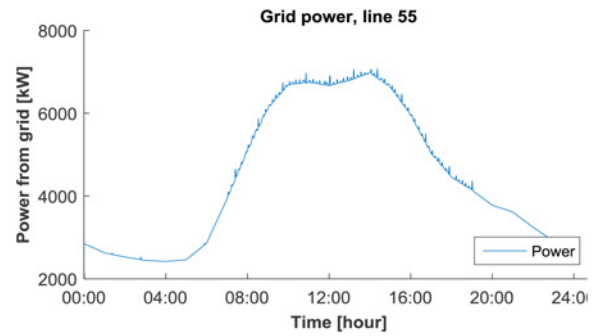

Fig. 6 Load profile Chalmers grid including bus charging based on measurement

system is strong and only covers a small geographical area, i.e. the lengths of the feeders are short.

4.4 Residential area

For the simulations of the residential area, the measured charge profile from the electric bus has been used to assess the potential impacts on the distribution system.

To find the maximum available capacity in the grid, simulations were conducted with the objective function being maximising the charge power. The location of the charge station was varied to assess the impact at the different nodes in the distribution system. As for the case with the real charger at Chalmers campus, a dedicated transformer for the charge station was considered in the simulations.

Fig. 7 presents the available capacity at the different buses in one of the feeders in the distribution system for the cases with/without active strategies, i.e. ESS and DR. As can be seen, the available capacity increases with both strategies, although the difference is limited for the size of ESS and responsive customers assumed (12.5 kWh and 10% responsive customers). The capacity increases with ~65 kW for the ESS, which is lower compared with what could be calculated from (1). The reason for this is due to the discharge rate was limited to 5C (of the usable capacity). With DR, the capacity is slightly higher compared with the case with ESS. However, since the ESS is connected to the same node as the charge station, the influence on the peak demand in that node would be higher for the case with ESS compared with DR.

It should be noted that the capacity is enough for at least two charge stations in any node without require reinforcements in the distribution system. However, the DSO in Gothenburg design their system according to the $N-1$ criterion to maintain a high reliability. In the simulated area, this redundancy is not available for the simulated day and the charging of electric buses would

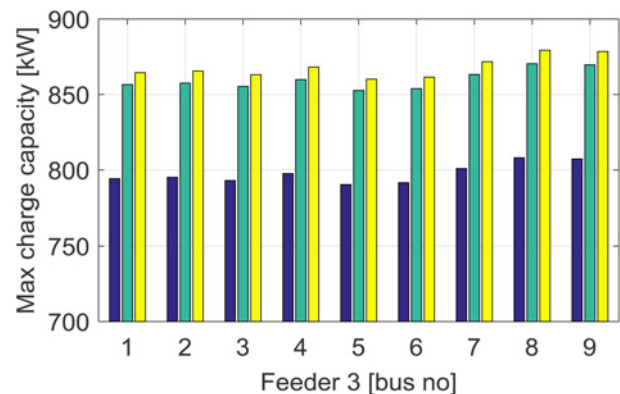

Fig. 7 Available charge capacity in the residential area without any strategy (blue) and with ESS (green) and DR (yellow)

reduce the possibility further. The limiting factor was found to be the current limitation in the feeder cable; hence, the peak capacity is almost constant for the different nodes. As a consequence, the location of the charge station would not affect the result significantly for the studied feeder and almost 800 kW charge power could be distributed anywhere within the system. For feeders/systems with large voltage variations, the location/distribution of the charge stations within the grid could have a larger effect on the capacity.

Regarding the losses, the charge station has a limited influence on the total losses in the distribution system for the simulated day, ~13 kWh increase. However, this is based on the measured charge profile, e.g. including plug-in hybrid electric buses, for a line with solely electric buses, the impact would increase. With the assumed size of the ESS, the losses will stay in the same range while they will be slightly reduced for the case of DR, ~12 kWh reduction compared with the case without DR. The reason for the higher loss reduction for the case with DR is due to that more energy is shifted in time compared with the case with ESS and that it is more distributed in the system. The reduction in losses does not solely justify the investment cost associated with the ESS or DR strategies. On the other hand, there could be alternative gains that make the investment more lucrative, such as for areas with large number of solar photovoltaics or to enable the possibility to connect the charger to the 400 V grid. It could also have an economic incentive for the owner of the charge station by reducing the connection fee and demand charges. However, due to the large fluctuation in the charge power, the hourly average demand is relative low. Since the demand charges generally are based on the hourly average demand, the incentive for the owner of the charge station to invest in e.g. ESS is limited under current market structure.

Another alternative to reduce the impacts of bus charging could be to use reactive power compensation. However, this alternative has not been investigated in this paper. Interested readers are referred to [12] for more detailed treatment of this topic.

5 Conclusions

This paper presents measurements from a fast-charging station for electric buses in Gothenburg, Sweden, and an investigation on the grid impacts caused by the fast electric bus charger. Alternatives for reducing the grid impact have also been investigated, including energy storage at the charge point and DR of the customers connected to the distribution system. It has been found that in the area where the charger has been connected (i.e. at the Chalmers

University campus), the impact is limited, mainly due to the fact that the grid is strong grid and has short cable lengths. For a weaker residential distribution system, the additional load due to bus charging could be handled without any overloaded components or voltage issues for charge power up to 800 kW. With an increased charge power or more electric bus routes, the impact may not be negligible. By installing an energy storage or using DR, the possible hosting capacity for bus charging could increase, but the possible impact is affected by the frequency of the buses on the bus line.

6 Acknowledgments

The authors are grateful for the financial support from Energiforsk/ELEKTRA and the Swedish energy agency. Furthermore, Göteborg Energi and Akademiska Hus are gratefully acknowledged for supporting the project with data.

7 References

- 1 Mahmoud, M., Garnett, R., Ferguson, M., *et al.*: 'Electric buses: a review of alternative powertrains', *Renew. Sustain. Energy Rev.*, 2016, **62**, pp. 673–684
- 2 Olsson, O., Grauers, A., Pettersson, S.: 'Method to analyze cost effectiveness of different electric bus systems'. Presented at the EVS29 Symp., Montréal, Québec, Canada, 2016
- 3 Mohamed, M., Farag, H., El-Taweel, N., *et al.*: 'Simulation of electric buses on a full transit network: operational feasibility and grid impact analysis', *Electr. Power Syst. Res.*, 2017, **142**, pp. 163–175
- 4 Ding, H., Hu, Z., Song, Y.: 'Value of the energy storage system in an electric bus fast charging station', *Appl. Energy*, 2015, **157**, pp. 630–639
- 5 Rogge, M., Wollny, S., Sauer, D.U.: 'Fast charging battery buses for the electrification of urban public transport – a feasibility study focusing on charging infrastructure and energy storage requirements', *Energies*, 2015, **8**, (5), pp. 4587–4606
- 6 Lindgren, L.: 'Full electrification of Lund city bus traffic – a simulation study', 2015, vol. 7255
- 7 'ElectriCity', *ElectriCity*. Available at <http://www.goteborgelectricity.se/>, accessed 15 January 2017
- 8 Rosenthal, R.E.: 'GAMS —a user's guide' (GAMS Development Corporation, Washington, DC, USA)
- 9 Steen, D., Tuan, L.A., Carlson, O.: 'Effects of network tariffs on residential distribution systems and price-responsive customers under hourly electricity pricing', *IEEE Trans. Smart Grid*, 2016, **7**, (2), pp. 617–626
- 10 'Eliq – a digital energy advisor for your home,' *Eliq*. Available at <http://eliq.io/>, accessed 15 January 2017
- 11 Steen, D., Tuan, L.A., Carlson, O., *et al.*: 'Assessment of electric vehicle charging scenarios based on demographical data', *IEEE Trans. Smart Grid*, 2012, **3**, (3), pp. 1457–1468
- 12 Steen, D., Le, T., Carlson, O.: 'Fast charging of electric buses in distribution systems'. Presented at the Power-Tech, Manchester, 2017