



A comparison of ship manoeuvrability models to approximate ship navigation trajectories

Downloaded from: <https://research.chalmers.se>, 2026-04-04 19:39 UTC

Citation for the original published paper (version of record):

Alexandersson, M., Daiyong, Z., Mao, W. et al (2023). A comparison of ship manoeuvrability models to approximate ship navigation trajectories. *Ships and Offshore Structures*, 18(4): 550-557. <http://dx.doi.org/10.1080/17445302.2022.2067409>

N.B. When citing this work, cite the original published paper.



A comparison of ship manoeuvrability models to approximate ship navigation trajectories

Martin Alexandersson, Daiyong Zhang, Wengang Mao & Jonas W. Ringsberg

To cite this article: Martin Alexandersson, Daiyong Zhang, Wengang Mao & Jonas W. Ringsberg (2022): A comparison of ship manoeuvrability models to approximate ship navigation trajectories, Ships and Offshore Structures, DOI: [10.1080/17445302.2022.2067409](https://doi.org/10.1080/17445302.2022.2067409)

To link to this article: <https://doi.org/10.1080/17445302.2022.2067409>



© 2022 The Author(s). Published by Informa UK Limited, trading as Taylor & Francis Group



Published online: 01 May 2022.



Submit your article to this journal [↗](#)



Article views: 290



View related articles [↗](#)



View Crossmark data [↗](#)

A comparison of ship manoeuvrability models to approximate ship navigation trajectories

Martin Alexandersson ^{a,b}, Daiyong Zhang^a, Wengang Mao ^a and Jonas W. Ringsberg ^a

^aDepartment of Mechanics and Maritime Sciences, Chalmers University of Technology, Gothenburg, Sweden; ^bSSPA Sweden AB, Gothenburg, Sweden

ABSTRACT

It is essential to describe a ship's manoeuvrability for various applications, e.g. optimal control of unmanned surface vehicles (USVs). In this study, the capability of two recognised manoeuvrability models to predict ships' trajectories is investigated based on both simulation and open-water experiment test data. The parameters of these models are estimated by a statistical learning method. The goodness of the two estimated models for describing a merchant ship's manoeuvrability is first studied using her manoeuvring simulation data. Then, experimental manoeuvring tests to use a USV in open water with wind and drifting effects are used to check the conventional model identification procedures. Finally, some modifications and adjustments are proposed to improve the conventional procedures. It shows that the proposed procedures can accurately derive the ship's manoeuvrability based on experimental data.

ARTICLE HISTORY

Received 5 October 2021
Accepted 11 April 2022

KEYWORDS

Manoeuvrability models;
ship trajectory; parameter
identification; statistical
regression

1. Introduction



A ship's manoeuvrability determines its capability to change course under certain navigational conditions (IMO 2002). For the optimal control of unmanned ships, it is important to establish their manoeuvrability models to design the autonomous control parameters. Five recognised models are often used to describe a ship's manoeuvrability (Hochbaum et al. 2008), i.e. the test data based methods, empirical models, free-running model tests, computational fluid dynamic (CFD) methods, and the mathematical model-based simulation. The CFD method can directly estimate a ship's hydrodynamic parameters with high precision, but it is time-consuming (Terziev et al. 2018). Hence, the free-running tests with parameter identification methods are considered as a practical solution to model a ship's manoeuvrability. A ship's manoeuvrability model is normally recognised as a rigid-body model with 6 degrees of freedom (DOF), which includes a set of differential equations (Skjetne et al. 2004). Abkowitz (1964) simplified the model by a third-order Taylor expansion, where the ship-body, rudder, and propellers are treated as individual parts of the rigid body (Ogawa et al. 1977). The force and moment of the rigid body are measured/calculated to estimate the ship's motions. The unified theory was used to model loads and motions on the 3 DOF rigid-body model (Fossen 2011). A response model by Nomoto et al. (1957) assumes the rigid-body movement, where a ship's heading change is related to the rudder angle. It is also known as the KT model widely used for ship autopilot (Tomera 2010). To get ship hydrodynamic parameters to build manoeuvrability models, planar motion mechanism (PMM) and open-water tests are often used in the analysis of different model parameters (Farkas et al. 2018). Based on the data collected from either zigzag and turning circle simulations or experimental tests, many methods are used to analyze and identify the parameters of Abkowitz and KT models. A back-stepping procedure was used by Casado and Ferreiro (2005)

to identify the parameters of the linear KT model. The particle swarm optimisation and support vector machine was used to identify the parameters in the Abkowitz model (Luo et al. 2016; Wang et al. 2021). However, those complex identification methods do not always generate robust models to accurately describe a ship's manoeuvrability, especially when genetic algorithms are involved in the parameter optimisation. For the optimal control of USVs, a fast method that can handle noise data to establish an on-line manoeuvrability model is often required (Bertaska et al. 2015). Additionally, most methods are verified by the simulation manoeuvring data. Ship navigation in an open-water environment is rarely used for the model identification.

In this study, a fast system identification technology based on the least square (LS) and support vector machine (SVM) methods was investigated, using both simulation data and experimental tests in open water with drifting effects. Both the Abkowitz and the second-order response KT models were used for modelling purposes and are briefly introduced in Section 2. In Section 3, the least-square support vector machine method is presented to identify parameters of the manoeuvrability models. The comparison results and conclusions are given in Sections 4 and 5, respectively.

2. Description of a ship's motion/manoeuvrability models

Ship motion and manoeuvring control can be designed using ship kinematics models. Figure 1 presents two commonly used 6 and 3 DOF models. The 6 DOF model includes a ship's surge, sway, heave, roll, pitch, and yaw movements, while the 3 DOF model only consists of the surge, sway, and yaw. For surface vessels, the 3 DOF model is more widely used in ship manoeuvring simulations. In this study, the Abkowitz and non-linear KT models were used to investigate a ship's

CONTACT Wengang Mao  wengang.mao@chalmers.se  Department of Mechanics and Maritime Sciences, Chalmers University of Technology, Gothenburg 41296, Sweden

© 2022 The Author(s). Published by Informa UK Limited, trading as Taylor & Francis Group

This is an Open Access article distributed under the terms of the Creative Commons Attribution-NonCommercial-NoDerivatives License (<http://creativecommons.org/licenses/by-nc-nd/4.0/>), which permits non-commercial re-use, distribution, and reproduction in any medium, provided the original work is properly cited, and is not altered, transformed, or built upon in any way.

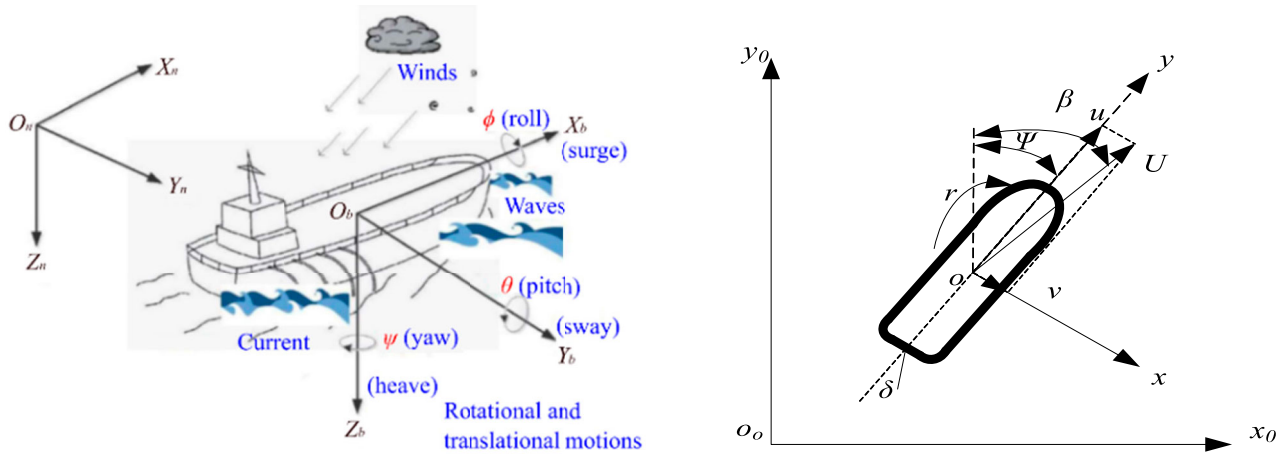

Figure 1. 6 DOF ship hydrodynamic model (left) and 3 DOF model (right). (This figure is available in colour online.)

manoeuvrability modelling, and the parameters of each model were obtained from either the free-running simulation or open-water tests.

2.1. The Abkowitz model

The Abkowitz model is a Taylor series expression of the 3 DOF marine hydrodynamic forces and moments. For the surface ships, the three-dimensional model can be expressed by:

$$\begin{bmatrix} m' - X'_{\dot{u}} & 0 & 0 \\ 0 & m' - Y'_{\dot{v}} & m'x'_G - Y'_{\dot{r}} \\ 0 & m'x'_G - N'_{\dot{v}} & I'_Z - N'_{\dot{r}} \end{bmatrix} \begin{bmatrix} \dot{u}' \\ \dot{v}' \\ \dot{r}' \end{bmatrix} = \begin{bmatrix} F'_1 \\ F'_2 \\ F'_3 \end{bmatrix}, \quad (1)$$

where m' is the non-dimensional mass of the ship (a constant value in the model), I'_z is the non-dimensional inertia moment of the Z-axis, x'_G is the non-dimensional longitude of the ship's gravity, and the parameters ($X'_{\dot{u}}$, $Y'_{\dot{v}}$, $Y'_{\dot{r}}$, $N'_{\dot{v}}$, $N'_{\dot{r}}$) are the non-dimensional acceleration derivatives (see Wang et al. 2021). The input parameters (\dot{u}' , \dot{v}' , \dot{r}') are the non-dimensional small accelerations from nominal surge speed u , sway speed v , and yaw speed r , respectively. F'_1 , F'_2 , and F'_3 in Equation (1) are approximated by Taylor series expression in terms of 60 third-order hydrodynamic motion coefficients (Fossen 2011):

$$\begin{aligned} F'_1 &= [a_1, a_2, \dots, a_{16}] \times [u', u'^2, u'^3, v'^2, r'^2, v'r', \\ &\quad \delta'^2, u'\delta'^2, v'\delta', r'\delta', u'v'\delta', u'v'^2, u'r'^2, u'v'r', u'r'\delta', 1]^T, \\ F'_2 &= [b_1, b_2, \dots, b_{22}] \\ &\quad \times \left[\begin{array}{l} u', u'^2, v', r', \delta', u'v', u'r', u'\delta', v'^3, r'^3, \delta'^3, u'^2v', u'^2r', \dots \\ u'^2\delta', v'^2\delta', v'^2r', r'^2v', r'^2\delta', \delta'^2v', \delta'^2r', r'v'\delta', 1 \end{array} \right]^T, \\ F'_3 &= [c_1, c_2, \dots, c_{22}] \\ &\quad \times \left[\begin{array}{l} u', u'^2, v', r', \delta', u'v', u'r', u'\delta', v'^3, r'^3, \delta'^3, u'^2v', u'^2r', \dots \\ u'^2\delta', v'^2\delta', v'^2r', r'^2v', r'^2\delta', \delta'^2v', \delta'^2r', r'v'\delta', 1 \end{array} \right]^T \end{aligned} \quad (2)$$

in which a_i , b_i , and c_i are the model coefficients to be identified, and δ is the rudder angle. The non-dimensional input

parameters of the above equations can be written as:

$$\dot{u}' = \frac{\dot{u}L}{U^2}, \quad \dot{v}' = \frac{\dot{v}L}{U^2}, \quad \dot{r}' = \frac{\dot{r}L^2}{U^2}, \quad u' = \frac{u}{U}, \quad v' = \frac{v}{U}, \quad r' = \frac{rL}{U}, \quad (3)$$

$$U = \sqrt{(U_0 + u)^2 + v^2},$$

where U_0 is the initial or pre-defined ship speed and U is the instantaneous speed along a trajectory.

2.2. The nonlinear KT model

The nonlinear KT model used here is an extension of the second-order KT model (Nomoto et al. 1957), which describes a ship's heading change in terms of setting rudder angles viz,

$$\begin{aligned} T_1 \cdot T_2 \cdot \ddot{r} + (T_1 + T_2)\dot{r} + K \cdot (\alpha_0 + \alpha_1 r + \alpha_2 r^2 + \alpha_3 r^3) \\ = K(\delta + T_3 \cdot \dot{\delta}), \end{aligned} \quad (4)$$

where r is a ship's heading turn rate (yaw speed), δ is the rudder angle, and the other coefficients K , T_1 , T_2 , T_3 , and α_i are KT model parameters to be estimated from the time series of ship manoeuvring tests. To simplify the KT model, α_0 and α_2 were taken as 0 due to ship symmetry. The KT model in Equation (4) is a 1 DOF ship model. To predict a ship's sailing trajectories by the model, her sailing speed U may be assumed as the initial pre-defined speed U_0 . As described in the more complex Abkowitz model, a ship's speed change due to rudder turning follows a periodic trend during the tests. In this study, the ship's instantaneous speed U when reaching steady conditions was modelled as:

$$U = V_1 \cdot \cos(\omega_1 t) + V_2 \cdot \sin(\omega_2 t), \quad (5)$$

where all coefficients (V_1 , ω_1 , V_2 , ω_2) were estimated by regression analysis.

3. Parameter identification based on LS-SVR

Support vector regression (SVR) uses support vector machines (Breerton and Lloyd 2010) to fit a hyperplane with a margin of tolerance ε that minimises the error between the observed output T_d and the predicted value \hat{T}_d . For the regression of coefficients in the Abkowitz model, T_d is taken as calculated by the left side of Equation (1), and \hat{T}_d is taken as Equation (2). For example, to build the Abkowitz model as in Equation (1), ship motion-related variables (u , v , r) must be estimated from the data. For the simulation data, the ship

service speed U_0 is known as a fixed value. The ship hydrodynamic motion response at the i -th time step can be easily estimated by:

$$\begin{cases} r_i = \frac{\Delta\beta_i}{\Delta t}, \Delta\beta_i = (\beta_{i+1} - \beta_i) \approx \Delta\psi_i & \dot{r}_i = (r_{i+1} - r_i)/\Delta t \\ u_i = U_i \cdot \cos(\Delta\beta_i) - U_0 & \dot{u}_i = (u_{i+1} - u_i)/\Delta t \\ v_i = U_i \cdot \sin(\Delta\beta_i) & \dot{v}_i = (v_{i+1} - v_i)/\Delta t \end{cases}, \quad (6)$$

where U_i is the instantaneous ship speed at the i -th time step. If these parameters are calculated from the simulation data without influences from wind/current/current, a ship's heading change $\Delta\beta$ is approximately equal to her course change $\Delta\psi$ between two adjacent time steps. The above Equation (6) may be used to obtain all the input parameters to identify the coefficients in Equation (2) of the Abkowitz manoeuvrability model. However, for actual ship sailing with drifting (wind/currents), it may not be so simple to obtain all these parameters using Equation (6). This is further discussed below, and a new approach is proposed. For regression of the KT model, $T_d = \ddot{r}$, and the other part in Equation (4) was used to get \hat{T}_d . The SVR estimated coefficients of the two models in Equations (1) and (5) by minimising the objective function:

$$\text{Obj} = C \cdot \sum_i l_\varepsilon(T_{d(i)}, \hat{T}_{d(i)}) + \frac{1}{2} \|\mathbf{w}\|^2, \quad (7)$$

where \mathbf{w} is the normal vector to describe the predicted values as $\hat{T}_d = \mathbf{w}^T \phi(\mathbf{x})$ (\mathbf{x} contains the ship motion variables, rudder angles, etc., as in Equations (2) and (4)), C is the regularisation parameters, and l_ε is the ε -insensitive loss function. Getting the hyperplane model for \hat{T}_d is a convex optimisation problem that is solved by introducing the Lagrange multipliers. Additionally, the insensitivity factor ε also restricts the sparsity and regression accuracy of the solution. It is set as 0 for the ship manoeuvring simulation tests. The parameter identification is also strongly dependent on the value of C . To optimise the solution, the LS-SVM is applied to find the best choice of C .

4. Case study based on ship manoeuvring tests

Two types of manoeuvring tests were used to study the capabilities of the two manoeuvrability models for predicting a ship's sailing trajectories, i.e. zigzag simulation tests from the MSS toolbox Mariner (Perez and Fossen 2009), and open-water experimental tests using a ship model with a scale of 50:1. Both the simulation and experiment tests followed the ITTC test standards. For the open-water experimental tests, several high-precision sensors were installed as in Figure 2, such as the compass, rudder angle sensors,

differential global position system (GPS), etc. The recorded data include the UTC time, location, heading, course, rudder angle, and rudder command.

4.1. Comparison of models based on simulation test data

Several 20°/20° zigzag simulation tests were conducted using the toolbox MSS Mariner. For the simulation, the initial speed was approximately 7.7 m/s; u , v , r , heading, and rudder angle were set to 0. The total simulation time was 200 s with an interval of 0.1 s. Coefficients of the Abkowitz and KT models were estimated by using the above LS-SVM method. The parameters were very sensitive to the choice of the regularisation factor C . Some key coefficients identified by the LS-SVM method were verified by values given in the simulation toolbox, as in Table 1. They were quite close to their actual values even though the optimisation process required a long time for searching. After the identification of those coefficients, the ship hydrodynamic motion parameters (u , v and r) were predicted and compared with the simulation results in Figure 3. Since the MSS Mariner ship navigates at a constant speed, the surge speed is the small perturbation about the service speed U_0 after reaching steady conditions. They generally agreed well. While the results for sway speed v did not work well. For the r , both the Abkowitz and KT models gave good results in comparison with the simulation data. For the sway speed v shown in the middle figure, the predicted sway speed v based on the KT model differs slightly from the simulation results. Since the KT model was a 1 DOF model, the results are acceptable for the heading prediction as in Figure 4, which presents the prediction of heading and trajectories (locations). The identified Abkowitz model predicts almost perfect results due to the obtained same model parameters in Table 1. The trajectory predicted by the KT model also agrees well with the simulated data, even though discrepancies exist in yaw prediction.

4.2. The Abkowitz model used in the experiment tests

Simulation data is recognised as the most stable and reliable input for the identification of a ship's manoeuvrability model parameters. However, data collected during a ship's actual sailing/experimental environments often contains large amounts of noises. Furthermore, some input variables for model identification may not be calculated straightforwardly from the collected data, because of measurement noises, impact from surrounding environment, or simply measurement accuracy and accurate experimental control, etc. If the same procedure and equations as the above simulation tests were used

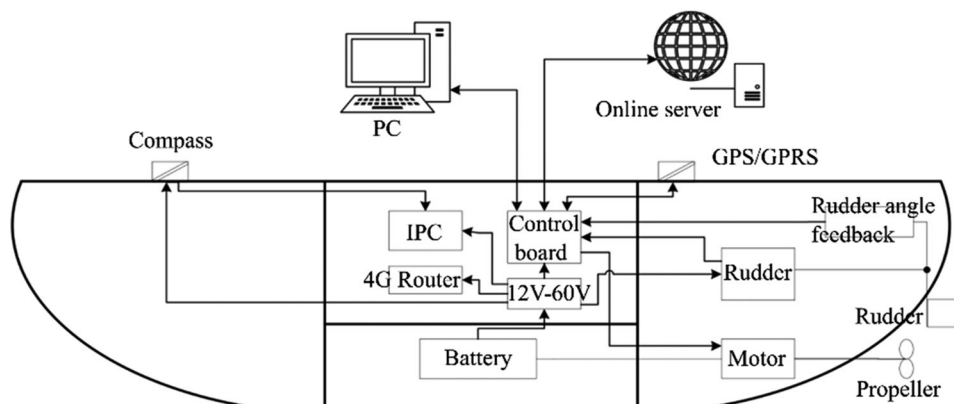

Figure 2. Configuration of sensors and equipment for the measurability of the experimental tests. (This figure is available in colour online.)

Table 1. Some of the identified non-dimensional model coefficients for the Abkowitz model as in Equation (2) ($\times 10^{-5}$).

F_1 -coeffs	MSS/LS-SVM	F_2 -coeffs	MSS/LS-SVM	F_3 -coeffs	MSS/LS-SVM
u'	-184.0/183.9	v'	-1159.9/-1159.8	v'	-262.0/-264.1
v^2	-899.0/-906.1	v^3	-8078.5/-8414.7	r'	-166.0/-166.1
$v'r'$	798.0/793.4	$v'u'$	15,358.0/15,191.3	v^3	1636.0/1576.1
δ^2	-95.0/94.9	$v^2\delta'$	-1160.0/-1203.4	v^2r'	-5483.0/-5612.7
$v\delta'$	93.0/92.3	v^2r'	556.1/554.4	$u'\delta'$	-278.0/-277.8
$u'v'\delta'$	93.0/89.2	$u'\delta'$	1190.1/1239.6	$v^2\delta'$	-489.0/-536.5

to build the Abkowitz model, the comparison of u , v , and r presented in Figure 5 and the ship heading/trajectories presented in Figure 6 showed fundamental discrepancies or incapability of the Abkowitz model to describe the ship's manoeuvrability.

This is mainly because the input variables u , v , and r for the model identification are estimated from the noisy experimental data, which makes the estimation of those variables become unreliable or even gives wrong information about the ship's sailing status. For example, if the data from ship heading measurement sensors is

used to estimate the yaw rate r , the results are strongly affected by the ship drift caused by wind/current in the open-water experimental tests. Moreover, due to high sample frequency, very little 'noise' in the measurement of heading angle leads to large errors in the estimated yaw rate by differentiation. It will cause even big problems to get the u , v and further their accelerations, which needs to take the first and second derivatives from the measured data. Furthermore, to get the variables of u and v , the initial forward ship speed is not known or change continuously, because during

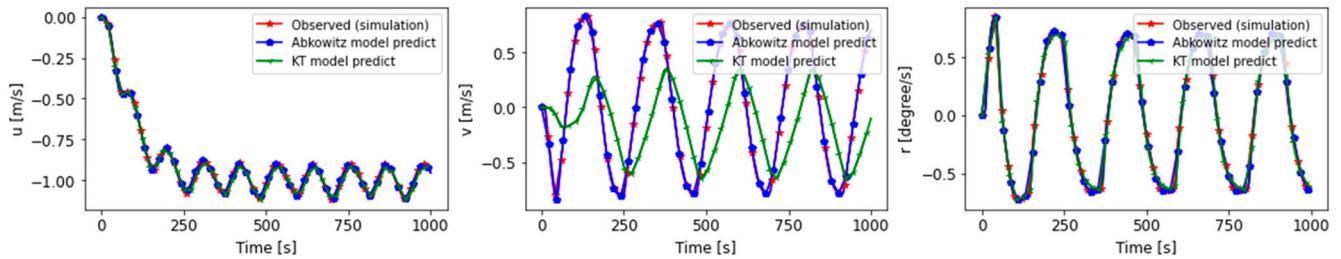
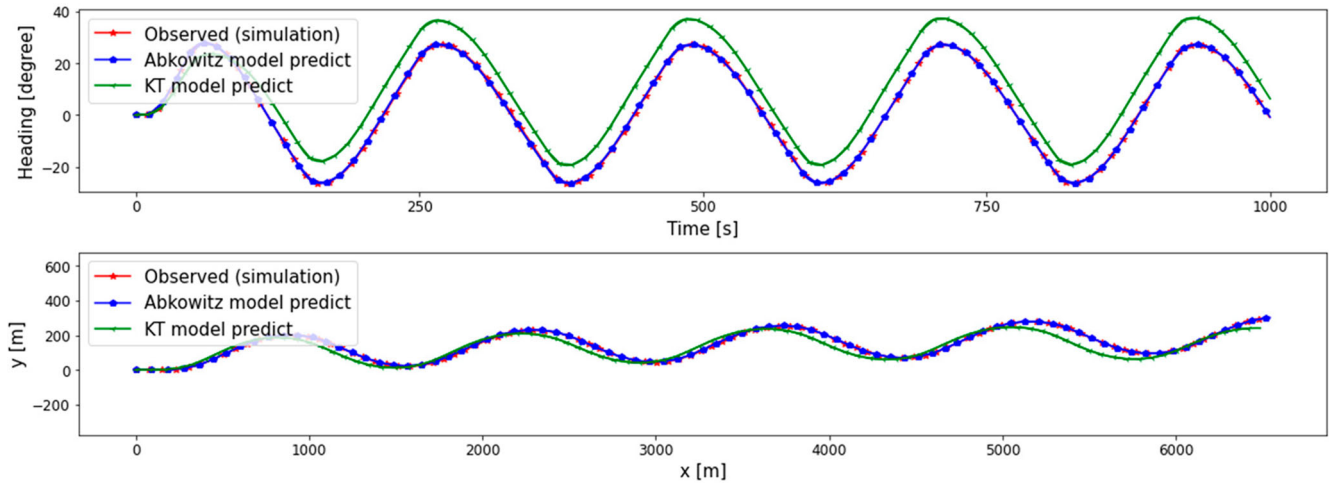
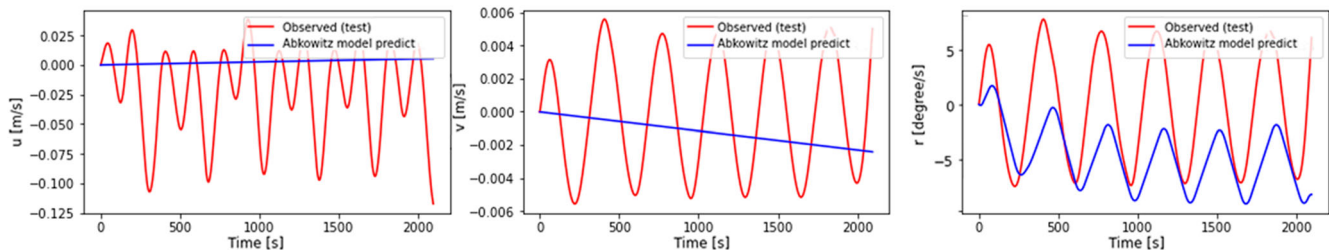
**Figure 3.** Comparison of the surge speed u , sway speed v and yaw rate r from the MSS Mariner using different models. (This figure is available in colour online.)**Figure 4.** Comparison of the MSS Mariner heading (upper) and trajectory (bottom) between the simulation and model estimation. (This figure is available in colour online.)**Figure 5.** Comparison of surge speed u , sway speed v and yaw rate r between Abkowitz model predicted and observed. (This figure is available in colour online.)

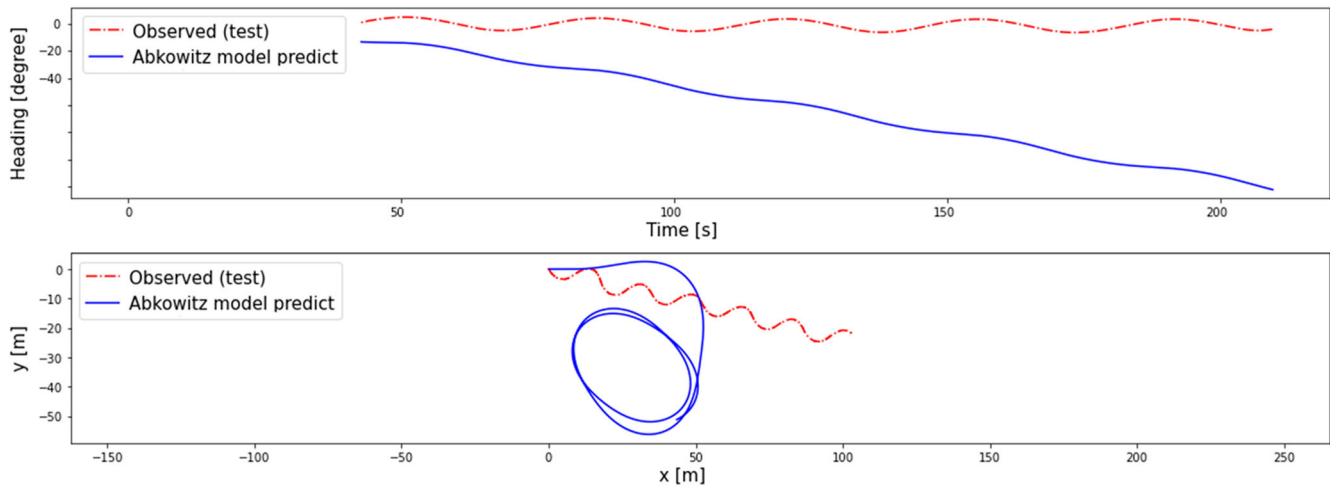

Figure 6. Ship heading (upper) and trajectory (bottom) predicted by the Abkowitz model in comparison with observed results. (This figure is available in colour online.)

the open-water manoeuvring test, a ship's pre-defined initial forward speed U_0 can hardly be controlled as fixed as pre-defined. All those noises and errors in the input variables estimated by the formulas originally from simulation scenarios may either destroy the physical interpretation of the Abkowitz model for a ship's manoeuvrability, or make it impossible to estimate the parameters in these models.

In this experimental study, the ship model was planned to navigate approximately at $U_0 = 0.6$ m/s, and the rudder angle was adjusted according to the zigzag test rule. All the sailing variables were reordered with a 10 Hz sample frequency. As shown in Figure 5, the observed surge speed u and sway speed v changed periodically. When those 'unreliable' input variables are used to identify the Abkowitz model describing the ship's manoeuvrability, the results of u and v predicted by the identified model show a stable decline trend and differ fundamentally from the observed data. For the yaw rate r , the predicted results can still reflect the periodic pattern, but there is a significant gap between the observed and the predicted data.

Finally, when the erratic parameters of u , v , r predicted by the model are used to calculate the ship's heading and trajectories, the results shown in Figure 6 show an even greater deviation between the observed data and that predicted by the model. Therefore, some new procedures should be proposed to get reliable inputs from experimental/full-scale test data, such as u , v , r , U , etc.,

for the LS-SVM to identify coefficients of ship manoeuvrability models.

4.3. Proposed procedure for parameter identification using experimental/noise data

The experimental/full-scale test data in open water used for identifying the Abkowitz model often contains many noises and errors that must be processed/removed. Additionally, some input parameters may be missing or may not be measured precisely with ease. They must be estimated from other more 'accurate' parameters. In this study, the data collection frequency was 10 Hz. As shown in Figure 5, the surge and sway speeds show different trends of variation in comparison with normal manoeuvring test data, as in Figure 3. Furthermore, the speed of the experimental test model ship was only approximately 0.6 m/s, it thus became unsuitable to use the original formulas of rigid-body ship movement to estimate her speeds of u and v as input parameters for the Abkowitz model. Therefore, a new process for collecting data, pre-processing data, and estimating parameters for model identification is presented in Figure 7. First, biased data, such as significant discrepancies between the normal trajectories, (u , v , r , etc.) were deleted. Then, the missing data were added using a simple linear interpolation method. The Kalman filter was used to smooth the results from the ship trajectory. To establish the accurate

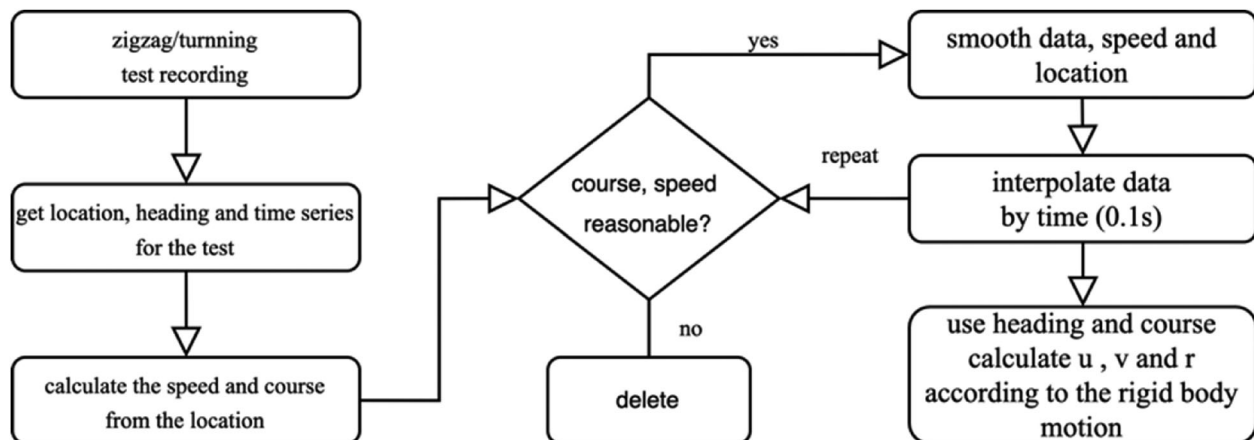

Figure 7. Flowchart for data processing to avoid noise, drift, and mean speed problems. (This figure is available in colour online.)

manoeuvrability Abkowitz model using collected data from experimental tests at open water with large random noises, the input parameters as in Equation (6) that estimate the coefficients cannot be used as the initial speed U_0 is uncertain. In this study, the parameters of u , v , and r were estimated using the geodetic coordinates in terms of observed instantaneous speed and course angle rather than a ship's heading β :

$$\begin{cases} u_i = U_i \cos(\psi_i) - \bar{U} \\ v_i = U_i \sin(\psi_i) \\ r_i = (\psi_{i+1} - \psi_i) / \Delta t \end{cases}, \quad (8)$$

where U_i and ψ_i represent a ship's instantaneous speed and sailing course at the i -th time step, and \bar{U} denotes the average ship speed. Finally, based on the parameters of u , v , and r using Equation (8) from the processed data, all the coefficients in the models were identified using the LS-SVM method.

5. Comparison of models obtained using experimental test data

To check if the proposed procedure could be used to obtain reliable inputs for identifying coefficients of various ship manoeuvrability models based on actual ship sailing data containing noises, both zigzag and turning circle tests were conducted using the ship model in the open water with wind, as in Figure 2. The collected data was used to verify the proposed procedure for the model identification as follows. The corresponding results for the zigzag and turning circle tests are presented in Figures 8 and 9, respectively. The zigzag test data was used to identify coefficients in both

the Abkowitz and KT models, which were then used to predict the ship's trajectory for comparison. Only the Abkowitz model was used for the turning circle test.

In comparison with the model identification using the simulation data, there were still some discrepancies due to uncertainties associated with the inputs of hydrodynamic motions, i.e. u , v , and r as shown by the upper plots in the two figures. However, the results obtained by the proposed procedures are greatly improved for the model identification using open-water test data when compared with the original method Equation (6), i.e. the results shown in Figures 5 and 6. The prediction of shipping trajectories is also acceptable after the initial tests of the proposed procedure. It should be noted that the improvement is achieved mainly by the proposed adjustment of estimation procedures as described in Section 4.3. In addition to the careful data cleaning and interpolation to delete illogical spikes and singularities within the ship state variables, the ship's heading is first estimated by more accurate GPS locations. This can avoid the impact of ship drifting on the estimation of a ship's actual navigation angles since the ship drifting forces are not considered in the Abkowitz and KT models. Then, big efforts should be put on the smooth of yaw angle r and navigation (course) angles, which normally contain some uncontrollable noises as in Figure 9 (upright plot). Another big change is that instead of using the GPS locations to estimate a ship's forward velocity, the well-smoothed course angles are used together with the GPS velocity to get the surge and sway motions u and v . Those proposed procedures will be further investigated and improved for practical applications.

For the shipping trajectory prediction by the identified model, in general, due to more coefficients in the 3 DOF Abkowitz model to

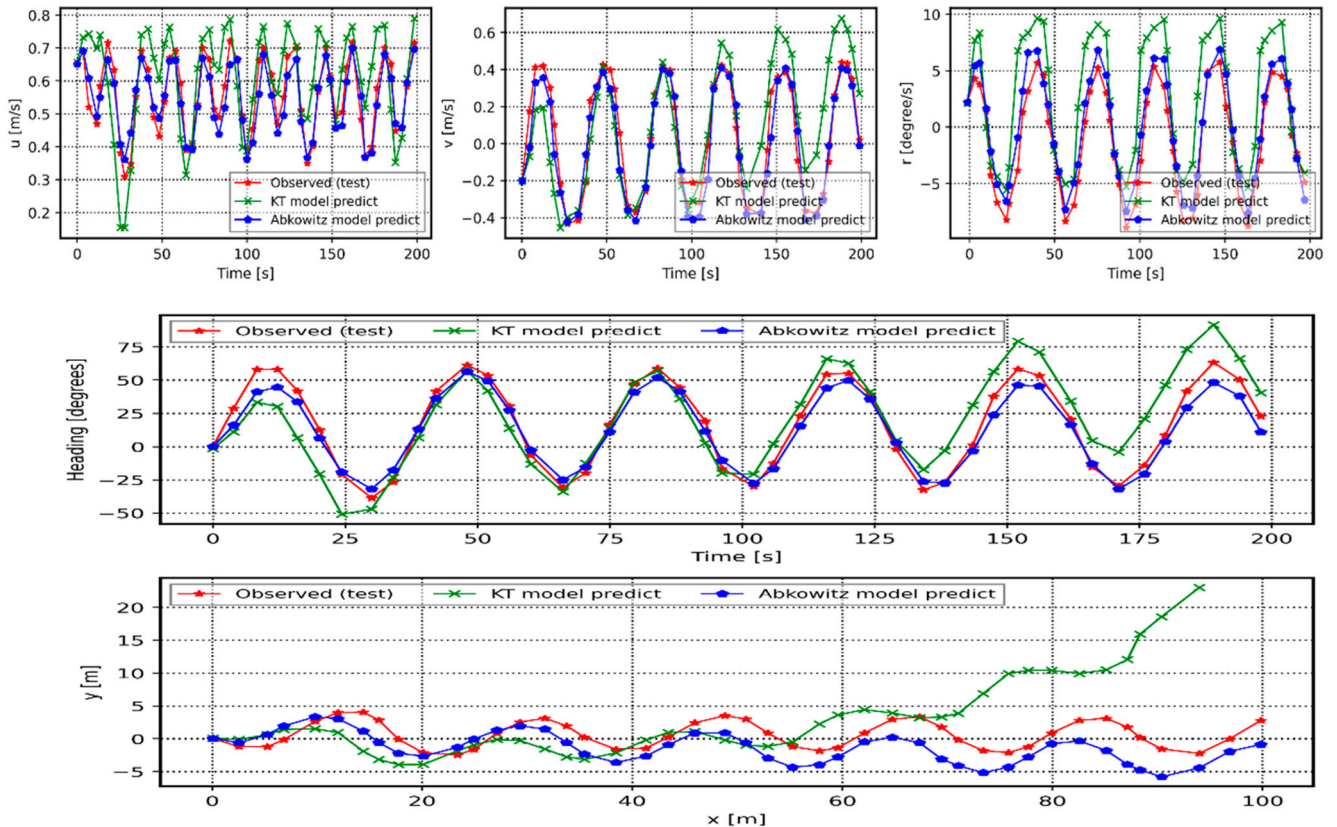

Figure 8. Comparison of surge speed u , sway speed v and yaw rate r (upper), ship heading (middle) and trajectories (bottom) between predicted by the identified Abkowitz and KT models and observed based on the experimental zigzag tests. Note that the observed (test) results in these plots are obtained after the data processing described in Figure 7. (This figure is available in colour online.)

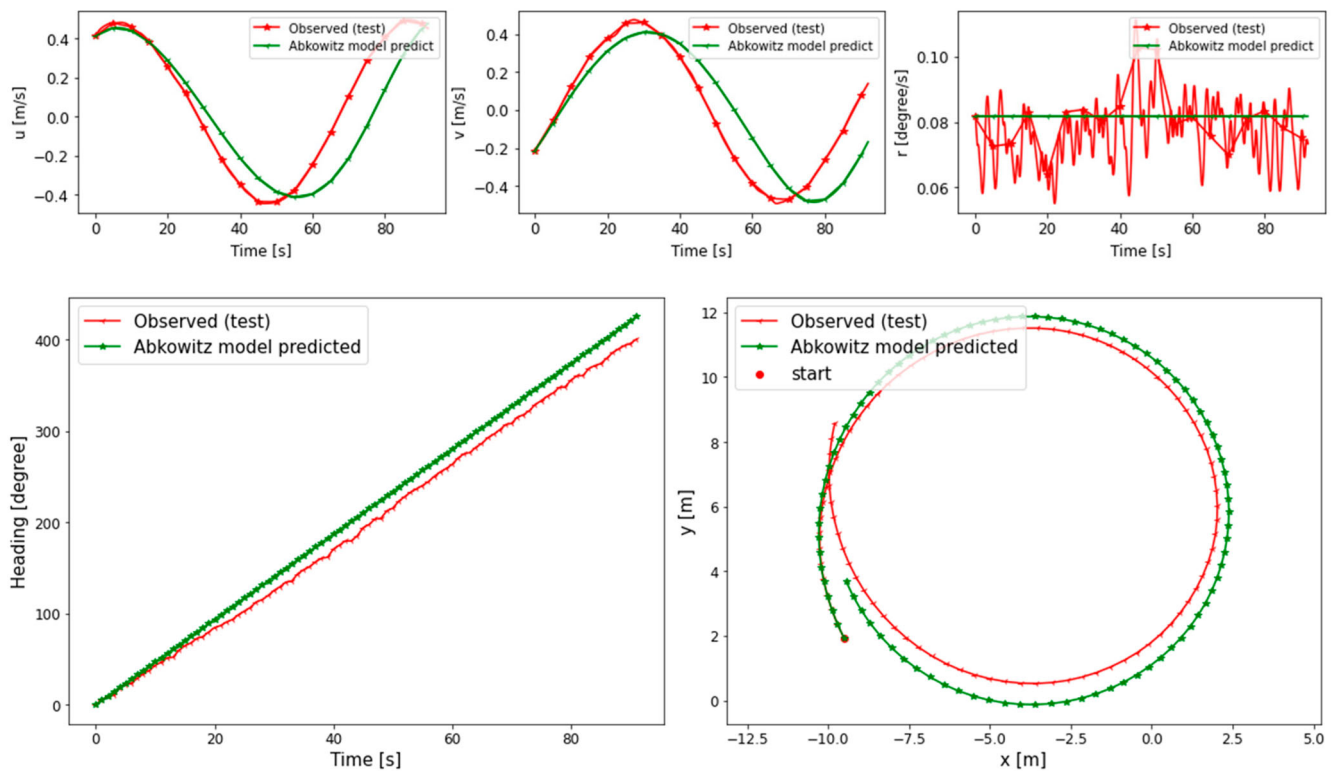

Figure 9. Comparison of surge speed u , sway speed v and yaw rate r (upper), ship heading and trajectories (bottom) between predicted by the identified Abkowitz model and observed based on the experimental turning circle tests. Note that the observed (test) results in these figures are obtained after the data processing described in Figure 7. (This figure is available in colour online.)

describe a ship's manoeuvrability, the sailing states, i.e. u , v , r and trajectories predicted by the Abkowitz model gave better results than the KT model. However, the KT model predicted well for the ship's heading/course change. For the zigzag trajectory, although the Abkowitz model gave very good predictions for u , v , and r , the trajectory was not perfectly predicted, which was not expected and deserves more investigation. The difference in the zigzag trajectory predictions by the KT model may have been due to the discrepancies in the predictions of v . This could also be investigated further in our future research.

The investigation using the turning circle tests showed similar trends as that of the zigzag tests. The identified Abkowitz model gave good predictions of the hydrodynamic motion response u and v . It should be noted that in the experimental tests in the open sea, the model ship was sailing much shorter and slower than the MSS Mariner simulation. All the test data may still contain a large amount of noise and uncertainties due to the accuracy of the sensors used in the open-water experimental tests. The prediction errors for r were also mainly caused by a lack of enough precision of the position/heading measurement sensors, leading to the discrepancy of predicted trajectories. These issues will be investigated in the upcoming studies.

6. Conclusions

In this study, the LS-SVM method was used for parameter identification in two manoeuvring models, i.e. the 3 DOF Abkowitz model and 1 DOF KT model, which are widely used for the control design of autonomous ships. The LS-SVM method was implemented to estimate/identify all coefficients within these two manoeuvrability models based on the test data from both simulation and open-water experimental tests. The implementation procedure was proposed to

estimate all inputs parameters from collected manoeuvring test data containing noises and drifting effects. The results indicate that the 3 DOF Abkowitz model gave more accurate predictions of ship sailing trajectories after identifying the model by the proposed method. The 1 DOF KT model also gave good predictions of ship heading/course turning rates, an important property of ship manoeuvring for autonomous shipping control. Furthermore, when a ship's forward speeds could be better modelled, the KT model also showed great potential to accurately predict a ship's sailing trajectories. The 3 DOF Abkowitz model identified by the proposed procedure can predict a ship's heading/course change and trajectories in terms of given rudder inputs. Concerning the simple form of the 1 DOF KT model and easy access of ship speed during sailing, it is expected that the KT model also has great potential to accurately predict a ship's heading and waypoints, subject to further development. This model could be used for fast online model identification to design optimal control of autonomous ship navigation.

Disclosure statement

No potential conflict of interest was reported by the author(s).

Funding

The authors would like to thank the Eurostars Programme (E!12881 E-NAV-R1), Swedish Transport Administration and Lighthouse (Swedish Maritime Competence Centre) for financial support to prepare this paper.

ORCID

Martin Alexandersson  <http://orcid.org/0000-0002-9360-078X>
Wengang Mao  <http://orcid.org/0000-0002-7126-1254>
Jonas W. Ringsberg  <http://orcid.org/0000-0001-6950-1864>

References

- Abkowitz MA. 1964. Ship hydrodynamics – steering and manoeuvrability. Lyngby: Hydro-and Aerodynamics Laboratory, Hydrodynamics Section. Report No. 5, Lectures.
- Bertaska IR, Brual S, von Ellenrieder K, Švec P, Klinger W, Sinisterra AJ, Dhanak M, Gupta SK. 2015. Experimental evaluation of automatically-generated behaviors for USV operations. *Ocean Eng.* 106:496–514.
- Brereton R, Lloyd G. 2010. Support vector machines for classification and regression. *Analyst.* 135:230–267. <https://doi.org/10.1039/b918972f>.
- Casado MH, Ferreira R. 2005. Identification of the nonlinear ship model parameters based on the turning test trial and the backstepping procedure. *Ocean Eng.* 32(11–12):1350–1369.
- Farkas A, Nastia D, Ivana M. 2018. Assessment of hydrodynamic characteristics of a full-scale ship at different draughts. *Ocean Eng.* 156:135–152.
- Fossen TI. 2011. Handbook of marine craft hydrodynamics and motion control. Chichester: Wiley. <https://doi.org/10.1002/9781119994138>.
- Hochbaum AC, Stern F, Agdrup K. 2008. Final report and recommendations to 25th ITTC. In: Proceedings of the 25th Information and Telecommunication Technology Center. Vol. 1, p. 143–208.
- IMO. 2002. Standards for ship manoeuvrability. https://puc.overheid.nl/nsi/doc/PUC_1807_14/1/.
- Luo W, Guedes Soares C, Zou Z. 2016. Parameter identification of ship maneuvering model based on support vector machines and particle swarm optimization. *J Offshore Mech Arct Eng.* 138(3):031101.
- Nomoto K, Taguchi T, Keinosuke H, Susumu H. 1957. On the steering qualities of ships. *Int Shipbuild Prog.* 4(35):354–370.
- Ogawa A, Koyama T, Kijima K. 1977. MMG report-I, on the mathematical model of ship manoeuvring. *Bull Soc Naval Archit Japan.* 575:22–28.
- Perez T, Fossen TI. 2009. A Matlab toolbox for parametric identification of radiation-force models of ships and offshore structures. *Model Identif Control.* 30(1):1–15.
- Skjetne R, Øyvind S, Fossen TI. 2004. Modeling, identification, and adaptive maneuvering of cybership II: a complete design with experiments. *IFAC Proc.* 37(10):203–208.
- Terziev M, Tezdogan T, Oguz E, Gourlay T, Demirel YK, Incecik A. 2018. Numerical investigation of the behaviour and performance of ships advancing through restricted shallow waters. *J Fluids Struct.* 76:185–215. <https://doi.org/10.1016/j.jfluidstructs.2017.10.003>.
- Tomera M. 2010. Nonlinear controller design of a ship autopilot. *Int J Appl Math Comput Sci.* 20(2):271–280.
- Wang T, Li G, Wu B, Æsøy V, Zhang H. 2021. Parameter identification of ship manoeuvring model under disturbance using support vector machine method. *Ships Offsh Struct.* <https://doi.org/10.1080/17445302.2021.1927600>.