



Assessment of district heating and cooling systems transition with respect to future changes in demand profiles and renewable energy supplies

Downloaded from: <https://research.chalmers.se>, 2026-04-03 11:37 UTC

Citation for the original published paper (version of record):

Zhang, Y., Johansson, P., Sasic Kalagasidis, A. (2022). Assessment of district heating and cooling systems transition with respect to future changes in demand profiles and renewable energy supplies. *Energy Conversion and Management*, 268. <http://dx.doi.org/10.1016/j.enconman.2022.116038>

N.B. When citing this work, cite the original published paper.



Assessment of district heating and cooling systems transition with respect to future changes in demand profiles and renewable energy supplies

Yichi Zhang^{*}, Pär Johansson, Angela Sasic Kalagasidis

Department of Architecture and Civil Engineering, Division of Building Technology, Chalmers University of Technology, Gothenburg 412 96, Sweden

ARTICLE INFO

Keywords:

District heating and cooling
Climate change
Building renovation
Renewable energy
Bi-directional system
Thermal energy storage

ABSTRACT

District energy systems are about to shift towards closer temperature configurations, i.e. low-temperature district heating and high-temperature district cooling. Challenges and benefits of these transitions are mostly analyzed from a perspective of current energy demand and supply scenarios while the influence from future changes in these domains remains unknown. Based on a representative residential community in the Nordic district heating context, centralized district heating and cooling (DHC), ultra-low temperature district heating (ULTDH), and bi-directional fifth generation 5GDHC systems were assessed from technical, economical, and environmental aspects. Moreover, the applications of thermal energy storage (TES) and their roles in the future DHC systems were also investigated. The assessment was done by a generalized methodology framework, integrating the future changes, multiple operation scenarios modellings and system design optimizations. Results suggest that in the future low-energy building stock, the increased cooling demand makes the 5GDHC system the most economically attractive choice. In the supply side, with a 50% share of wind power in the future national grid, the electricity prices can make 5GDHC and ULTDHC either cost-saving or more expensive compared to the central DHC system dependent on if nuclear plants are decommissioned or not. Besides, with increasing power production from VRE, the limited application of TES for active shift of electricity demand is found when a system's heat-to-power ratio is high. The methodology framework can be applied to similar systems to increase the understandings on system transitions.

1. Introduction

1.1. Background

With a current share of 50 % in the final energy consumption, heating and cooling sector is the biggest energy end-use ahead of transport and electricity in Europe [1]. A major usage is in the households, where 79 % of the energy is used for space heating, water heating and space cooling [2]. According to the statistics in 2019, approximately 75 % of the needed energy is still generated by fossil fuels [2]. The European Commission adopted a set of proposals to reach the greenhouse emission target and long-term carbon neutrality [3]. Among these proposals, the transition of the heating and cooling sector is regarded as an important step [4].

District heating and cooling (DHC) enable efficient energy supply and low emissions while maintaining relatively lower costs compared to individual solutions. Thus, they are regarded as key technologies to decarbonize the European energy system [5]. The forth-generation

district heating (4GDH), which has a supply temperature close to the actual domestic hot water demand of around 60 °C, has been studied in recent years [6]. The lower operating temperature compared to the current level of around 80 °C lowers the grid losses and increases the integration potential of waste heat and renewable sources. These characteristics increase the overall system efficiency and make the 4GDH a future trend of the DHC system development [7].

Following the general concept of low temperature heating system, further innovations of DHC systems include ultra-low temperature district heating (ULTDH) and fifth-generation district heating and cooling (5GDHC). The ULTDH system has a forward temperature of around 35 °C to supply space heating (SH) directly, while decentralized heat pumps (HPs) are used to increase (boost) the network temperature to a required level, to fulfill the domestic hot water (DHW) demand [8]. Deep energy renovations of buildings and low-temperature indoor heating systems such as floor-heating are regarded as pre-requisite for the ULTDH system. The lower supply temperature reduces further the grid losses and increases the coefficient of performance (COP) of the main central HPs compared to the systems used today [9]. This idea has

^{*} Corresponding author.

E-mail address: yichi@chalmers.se (Y. Zhang).

<https://doi.org/10.1016/j.enconman.2022.116038>

Received 3 June 2022; Received in revised form 17 July 2022; Accepted 18 July 2022

Available online 31 July 2022

0196-8904/© 2022 The Authors. Published by Elsevier Ltd. This is an open access article under the CC BY license (<http://creativecommons.org/licenses/by/4.0/>).

Nomenclature			
4GDH	Fourth generation district heating	MEX	Maintenance expenditure
5GDHC	Fifth generation district heating and cooling	NUC	Nuclear
CAPEX	Capital expenditure	OPEX	Operational expenditure
COP	Coefficient of performance	PV	Photovoltaic
CHP	Combined heat and power	SC	Space cooling
DHC	District heating and cooling	SH	Space heating
DHW	Domestic hot water	SFH	Single-family house
EER	Energy efficiency ratio	SOC	State of charge
HP	Heat pump	TES	Thermal energy storage
LCOE	Levelized cost of energy	U-value	Overall heat transfer coefficient
MFH	Multi-family house	ULTDHC	Ultra-low temperature district heating and cooling
		VRE	Variable renewable energy

Table 1

An overview of the studies on the heating system performance with future changes.

Future changes	Systems	Storage	Evaluation aspects			Ref
			Technical	Cost	Emission	
Demand	3GDH and individual		✓	✓	✓	[32]
	3GDH, 4GDH and ULTDH		✓		✓	[31]
	4GDH and ULTDH	✓	✓	✓	✓	[12]
	4GDH and ULTDH		✓	✓		[13]
Price	3GDH		✓	✓		[33]
	HPs in rural area	✓	✓	✓		[34]
	3GDH	✓	✓	✓		[35]
	3GDH		✓	✓		[36]
	3GDH	✓	✓		✓	[37]
Local VRE	5GDHC + PV	✓	✓	✓		[38]
	5GDHC + PV	✓	✓	✓		[39]
	5GDHC + PV	✓	✓	✓		[40]
	5GDHC + PV, individual	✓	✓	✓	✓	[15]
	Solar 4GDH, individual	✓	✓	✓	✓	[41]

been applied in several residential buildings in Denmark [10] and compared to the 4GDH in a small community [11] and the whole country [12]. Despite the technical attractiveness, the feasibility of ULTDH is still questionable and will depend on the specific costs and efficiency of the booster HPs [11,13].

In comparison, the 5GDHC system has operating temperature close to the annual average of the shallow ground so that the heat loss from the DHC pipes to the environment is minimized [14] and the waste heat from cooling processes in buildings can be collected. The heating and cooling demand is supplied from the same network by using separate local booster HPs and chillers. The whole system is also referred to as *Bi-directional Network* [15,16] or *Cold District Heating Network* [17]. In general, the 5GDHC is more suitable in places with balanced heating and cooling demand. The idea is, thereby, more attractive for commercial districts in central and southern Europe, according to the statistical survey of 40 operating 5GDHC systems [14]. The 5GDHC is also compared to other systems in terms of exergy efficiency [18], environmental impact [19], and economic feasibility [15]. The results diverge largely because, as it will be shown in this work, the balance between increased investments and cost-saving benefits is strongly influenced by

applied scenarios.

Although the transitions of DHC systems were discussed in the above-mentioned studies, most of them were placed in the current situations and perspectives. Indeed, various future challenges and changes are expected to exist on the energy systems. On the demand side, with the on-going building renovation projects across Europe and the undeniable global warming, the heating and cooling demand are believed to be changed in the future [20]. In the supply side, the growing electricity production from variable renewable energy (VRE) is adding variations and uncertainties to the power grid. It is likely that both the future price level and price variability will be different from the current conditions [21]. However, whether the currently planned transition of DHC system is attractive under the future challenges is still a question which this study aims at answering. To proof the relevance of the research question, an overview of the future changes is provided in the following sections, and existing gaps associated with the transitions of DHC systems are summarized.

1.2. DHC systems with future changes

A major change in the future is the altering heating and cooling demand due to the ongoing global climate change [20,22,23]. Although uncertainties of the climate forecasts exist, it is unequivocal that the future climate will on average become warmer, which increases the cooling and decreases the heating demand [24]. Such change will reduce the efficiency and, thereby, the attractiveness of conventional centralized system while creating possibilities for the local energy systems, like the 5GDHC system. The uncertainties induced by different climate models on the building energy performance were estimated by Nik et al. [20]. Based on climate models and the degree day method, Larsen et al. quantified the changes of heating and cooling demands in European countries and concluded that the most significant changes are found in Nordic countries [25]. The previous studies [20,22–25] are mostly conducted from the perspective of buildings, and the influence of climate change on the theoretical heating and cooling demand is, thereby, well-known. However, on energy system levels, the performance and transitions under such changes are less considered. Andric et al. [26] evaluated the technical and economic performance of a district heating (DH) system in France under climate change. The study considered a conventional centralized DH system with boilers as the main source, which cannot reflect the future trend of DHC systems. An optimal decision about the transitions towards low-temperature systems shall be based on the foreseen changes in the demand, to assure a satisfying performance of a DHC for a long time in the future.

Another major change in the demand side is induced by the building renovation measures, which were planned in many countries [27,28] and recognized as essential steps to reach the carbon neutrality target. An average rate of 3 % annually for building renovations is suggested to accomplish the EU's energy efficiency ambitions [29]. Until now, deep

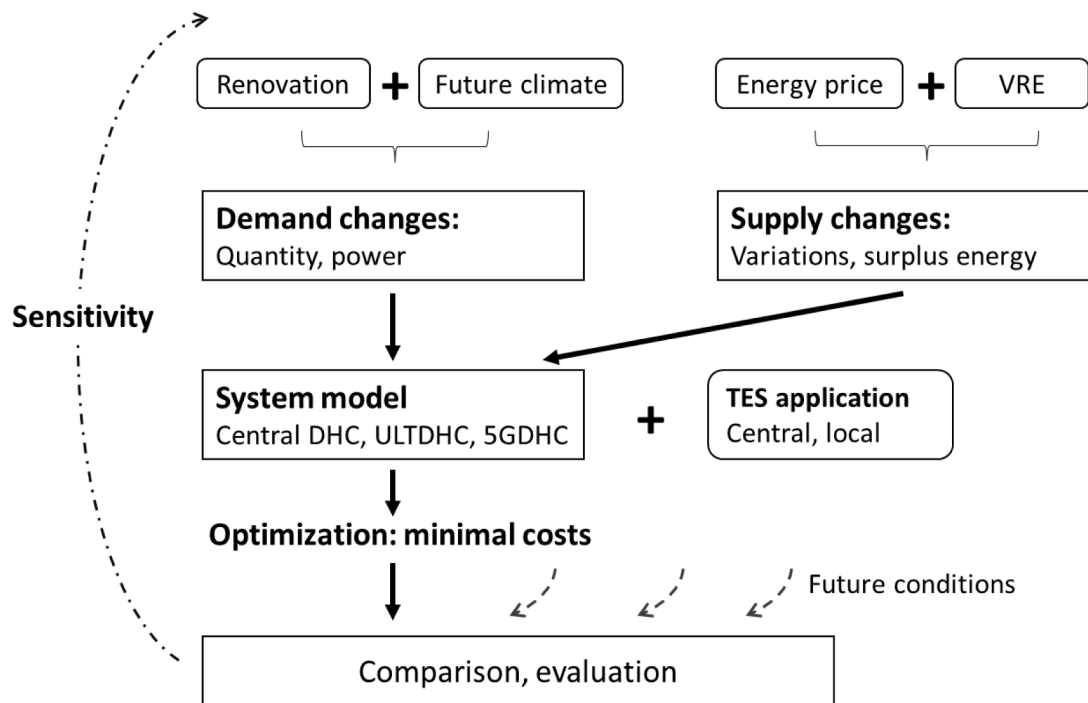

Fig. 1. Flowchart overview of the main methodology.

renovations that reduce the energy demand of buildings by at least 60 % are carried out at only 0.2 % of the building stock per year across EU [30]. Therefore, the EU commission published in 2020 a new renovation strategy, aiming at doubling the annual energy renovation rates in the next 10 years [30]. With a reduction of heating demand and demand density, the optimal design of DHC systems is inevitably influenced. Hence, the influence of renovation measures on the DHC systems was investigated in several research works, as summarized in Table 1. Nguyen et al. [31] studied the total annualized cost of three LTDH and ULTDH systems for a new residential area with four different land exploitation plans. The 4GDH option is found to be more cost efficient than the third-generation district heating (3GDH) and ULTDH systems. Similar finding is also presented in the case studies in Denmark [12,13]. It is concluded that the ULTDH system could become economically feasible if the investment for booster HP would be lower or the waste heat available [13]. As for the 5GDHC system, unlike other systems, the impact of building stocks renovations remains unknown. While most studies focus on districts with internally balanced heating and cooling demands [15–18], the advancing deep renovations will definitely change the balance and, thereby, alter the results valid at current situation. Therefore, the feasibility of 5GDHC system requires further investigations.

On the supply side, the future variations and uncertainties of electricity prices are mainly due to the increasing deployment of VRE, the probable further phase-out of nuclear plants, and the fossil fuel price unpredictability. Among the works focusing on varying prices, the one from 2012 [33] investigated the influence of four simplified price patterns on a local DH system with combined heat and power (CHP) plant in Uppsala, Sweden. The CHP plant is found to be sensitive to price changes. Due to this reason, most studies about the influence of future electricity prices are focused on traditional 3GDH and CHP plants [33,35–37]. Romanchenko et al. [37] constructed six price scenarios with different levels of wind power integration towards 2030 and found significant increases of average price and price variations with the phase-out of nuclear power. The viability of HP is also sensitive to the price changes as demonstrated through case studies on existing DH systems in Finland [36]. However, the scope of the aforementioned is on large, centralized HP system while the performance of ULTDH and

5GDHC systems under future prices has not been discussed.

Besides the changes from the national grid, the local district energy system will also change with the integration of available VRE such as rooftop photovoltaic (PV), as seen in studies on various 5GDHC and 4GDH systems presented in Table 1. In specific district energy system cases with certain VRE profiles, the overall system cost and VRE utilization rate were optimized through the temperature control in the network [38], the use of network inertia [39], the active thermal energy storage (TES), and batteries [40]. By combining analysis methods for various energy technologies, Wirtz et al. [15] further constructed an integrated design methodology for optimizing the sizes of all energy conversion units in a 5GDHC system. It was found that the bi-directional system has substantially lower cost, less emissions and better utilization of VRE compared to the individual system solutions. Similar ideas about the integrated optimization of energy equipment is also found in the study on a solar assisted 4GDH system [41], where the ratio of storage volume to solar collector area is analyzed to aid the system design. Despite that the integration of local VRE was widely studied as reviewed above, the focus was mostly on a given district energy system. The impact of local VRE on the system transitions towards different low-temperature system options has not been discussed. As the overall system efficiency and heat-to-power ratio will be improved in the future, the ability of using the VRE in different systems remains unknown.

On another note, TES technologies are widely used in DHC systems to offer flexibilities in matching the energy supply and demand on various time scales [42]. Combined with power-to-heat technologies such as heat pumps, synergies between the heating and electricity sectors are created [43]. Therefore, the applications and roles of different TES technologies in the 3GDH and 4GDH systems were identified in previous research works [42,44,45]. As for the ULTDH and 5GDHC systems with lower temperature ranges and, thereby, lower sensible storage densities, TES sizes were optimized in previous studies [15,18,40]. Corresponding to the research gap in system transitions and future changes, the applicability of TES under such challenges still requires further investigations.

Table 2

Basic parameters and the heating and cooling demand of current buildings. The U-value refers to the average thermal transmittance of the building component.

Building	Total area (m ²)	U-value (W/m ² ·K)			Demand (kWh/m ²)		
		Wall	Window	Roof	SH	DHW	Cooling
MFH	12,000	0.8	2.2	0.5	70.4	14.9	0.0
SFH	6,000	0.6	2	0.5	111.1	18.7	0.0
Office 1	2,520	0.8	1.8	0.5	46.0	2.4	10.2
Supermarket	2,400	1	1.8	0.5	55.6	3.3	12.7
Office 2	1,200	1	1.8	0.5	55.4	2.0	12.3

Table 3

Brief overview of the investigated DHC systems in this study and the design supply/return water temperatures.

Short name	Central sources	Local sources
Central DHC	City DH: HPs, 65/35 °C City DC: compression chillers, 12/20 °C	None
ULTDHC	Community: waste-water source low temperature HPs, 30 ~ 45/25 °C City DC: compression chillers, 12/20 °C	DHW booster HPs
5GDHC	Community: waste-water source low temperature HPs, 30 ~ 45/25 °C Community: natural cooling, 35/25 °C	DHW booster HPs Water-cooled chillers

1.3. Aim and scope

Considering the research gaps illustrated above, this study aims at assessing the DHC system transitions under future changes from both supply and demand side. Thereby, the study brings new and important insights because earlier research works typically assume unchanged operation situations such as the balanced heating and cooling demand in the district network. Based on a representative residential community in the Nordic district heating context, the future performance of the centralized DHC, ULTDH and 5GDHC systems, were evaluated from technical, economical, and environmental aspects. The major focus of the study is on how the system choices are influenced by the possible changes in the future. Moreover, the applications of TES and their roles in the future DHC systems were also investigated.

This paper is organized as follows: Section 2 explains the modelling methodologies and evaluation indexes. Section 3 introduces the investigated residential case and the DHC systems. Section 4 describes the future scenarios with climate changes, renovation measures, energy price changes, and local VRE integration. The influences of these changes on the system performance and TES applications are presented in Section 5. The discussions on the DHC system transitions and the roles of TES are provided in Section 6.

2. Methodology

An overview of the methodology framework is summarized in Fig. 1. The input parameters are the forecast changes in the future, which are explained in detail in Section 4. Under these challenges, three typical DHC systems, as introduced in Section 3, were modelled and compared. Section 2.1 explains the dynamic modelling methodology, adapted from a previous study [44]. The applications of TES technologies are explained in Section 2.2. The design and operation of the whole system is optimized with the objective of minimal costs. By comparing results from different scenarios, the influence of future changes on the DHC system transition is figured out. The methods for evaluating the techno-economic performance are introduced in Section 2.3. Although this study is based on a residential case, the generalized methodology framework integrating the future changes, dynamic system modellings and system design optimizations can be applied to similar systems to increase the understandings on system transitions.

2.1. System model and optimization problem

The models for the DHC systems are based on the dynamic system model developed for centralized DH system in a previous study by the authors [44]. In order to suit the purpose of modelling and optimizing decentralized systems, several amendments and simplifications were made. This section focuses on these changes and general modelling principles, while the detailed methodologies can be found in [44].

The demand for space heating and space cooling is calculated by a two-node capacities model with five resistances [46]. In this representation, each building is considered as one thermal zone with a uniform air temperature. The setpoints of indoor air temperature are 21 °C and 23 °C for heating and cooling, respectively, according to the Swedish industry standard for energy use in buildings (SVEBY) [47]. Occupancies for indoor activities and equipment powers are based on previous investigations of typical Swedish residential and commercial buildings [48]. Domestic hot water draw-off profiles are generated by stochastic modelling tool called *DHWcalc* [49]. Based on the profiles, the secondary DHW losses were calculated by assuming a representative length of circulation pipes and temperature difference, as stated in [50]. To fulfill the demand and losses, the local equipment such as heat exchangers and heat pumps are operated with given temperature setpoints.

Unlike the previous model, the hydraulic conditions of the DHC network are not modelled in the current study to linearize the whole system and simplify follow-up optimization process. The community network is represented by several thermal storage capacities, with homogeneously distributed temperature within each pipe. The temperature evolution $T_{network}$ for each pipe is explicitly written in Eq. (1). For transmission heat losses, a given heat loss rate of 0.1 W/(m·K) is used. For simplicity reason, fixed shallow ground temperatures of 5 °C during winter and 20 °C during summer are considered in this study, which represent typical ground temperatures of Gothenburg.

$$C_{network} (T_{network,\tau+1} - T_{network,\tau}) = (P_{inflow} - P_{outflow}) \cdot \Delta t \quad (1)$$

where τ is the time step. $C_{network}$ is the heat capacity of the water inside specific pipe. P_{inflow} and $P_{outflow}$ are inflow and outflow powers, which include the heat losses and the heat exchanged on the demand-side.

To maintain the stable system operation, the network temperatures are controlled to the design values, as specified in Table 3, by central heating and cooling sources in the investigated DHC systems. The models and parameters for the sources are explained in Appendix A.1.

Several TES technologies were considered in the system. Their design sizes and hourly operation strategies were decision variables for the optimization of the minimum annualized system cost. The capital expenditure (CAPEX) for the equipment, operational expenditure (OPEX), and the maintenance expenditure (MEX) were summed up in the following objective function, Eq. (2).

$$\min \text{cost} = \text{CAPEX} + \text{OPEX} + \text{MEX} \quad (2)$$

The annualized investment is calculated by considering an interest rate of 5 % according to the financial conditions in Sweden and the expectations of the system owner [51]. CAPEX comprises the investments for central and local sources, network, substations and heat exchangers, and the TES technologies, as expressed in Eq. (3). The

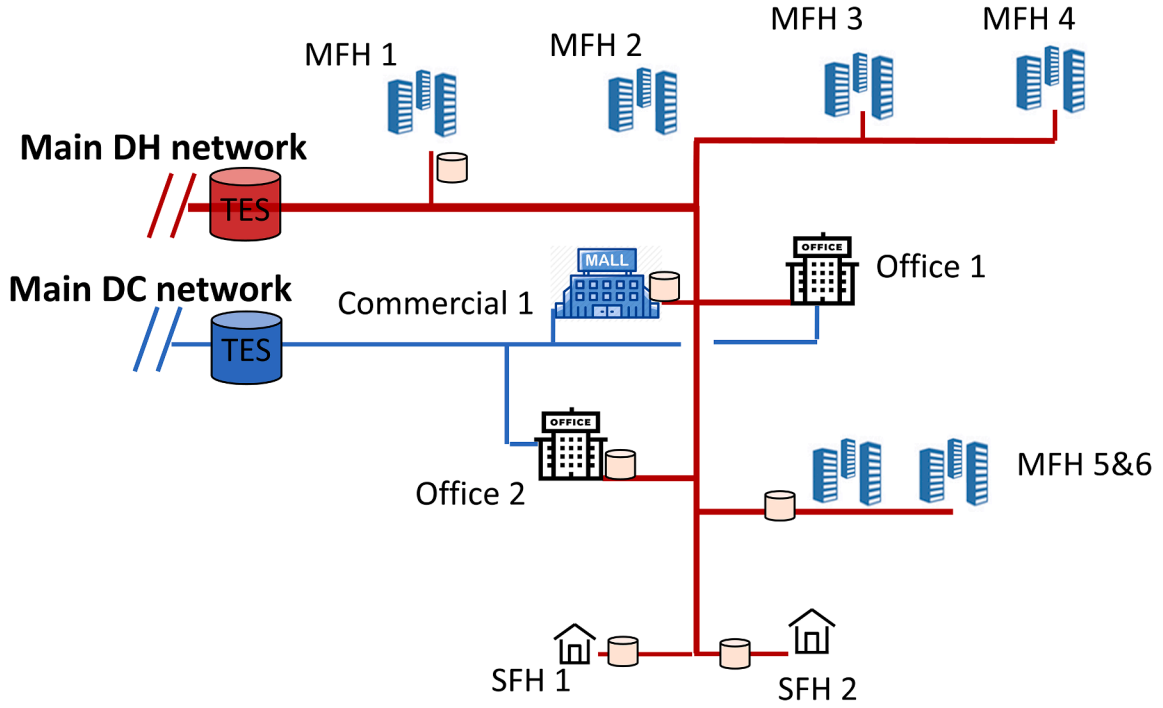

Fig. 2. Schematic diagram of the case community with central district heating and cooling system.

detailed economic parameters and maintenance rates are explained in Appendix A.2, based on the reports from previous projects and current market prices [52].

$$\text{CAPEX} = \text{CAPEX}_{\text{central}} + \text{CAPEX}_{\text{local}} + \text{CAPEX}_{\text{network}} + \text{CAPEX}_{\text{TES}} + \text{CAPEX}_{\text{substation}} \quad (3)$$

In this study, the OPEX refers to the electricity bills since the heating and cooling sources are all electricity driven. Detailed information about the heating and cooling sources can be found in Section 3. Energy consumptions of circulating water pumps were also calculated based on the flowrate data and assumptions of fixed pressure loss and pumping efficiency. This study considers the planning scenario of the energy systems where the peak power cost of the equipment is represented by CAPEX, as explained above. For calculating the OPEX, the electricity price comprises two parts. The fixed part is set as 80 €/MWh in Sweden, which is decided by the tax, network prices, and local factors. The variable part comes from various scenarios of future electricity prices, as further explained in Section 4.3. It shall be noted that the energy price models and investment scenarios could change the optimal system design and TES sizes [53]. In real operational cases, a peak power price is commonly charged by the local energy company to recover the peak equipment investment [54].

The charging and discharging operations of the TES units were optimized to utilize the variable electricity prices and increase the usage of high-efficiency sources while reducing the power costs of the equipment. The sizes of the TES units were also decision variables for optimization. In accordance with the whole system, the TES units were linearized to ease the optimization process, i.e., temperature distributions and stratifications inside the TES are not considered. General constraints were written in Eqs. (4)–(7).

$$P_{\text{source},\tau} + P_{\text{discharge},\tau} \geq P_{\text{demand},\tau} \quad (4)$$

$$\text{SOC}_{\min} \leq \text{SOC}_{\tau} + (P_{\text{charge},\tau} - P_{\text{discharge},\tau} - P_{\text{TES,loss}})\Delta t \leq \text{SOC}_{\max} \quad (5)$$

$$P_{\text{discharge},\tau} \leq P_{\text{discharge,max}} \quad (6)$$

$$P_{\text{charge},\tau} \leq P_{\text{charge,max}} \quad (7)$$

where $P_{\text{charge},\tau}$ and $P_{\text{discharge},\tau}$ are charging and discharging power at time step τ , respectively. Eq. (4) explains that the heating and cooling demand is fulfilled with the energy supply from sources $P_{\text{source},\tau}$ and discharged energy from TES. For each time step, the state-of-charge (SOC) of TES shall be within the maximum and minimum ranges, as expressed in Eq. (5). The powers for charging and discharging the TES are also within the design values, which are decided by the heat transfer characteristics and sizes of the TES, as explained in Section 2.2.

The whole model is developed and performed in MATLAB. The minimal time step is set as one hour in accordance with the demand profile. The Cplex solver is used to solve the linear optimization problem of the whole year, which needs around 15 min for each run on a Core-i9 5.2-GHz computer.

2.2. Energy storage unit design

To cover the most common applications of TES in DHC systems, four types of water tank were considered in this study, including the demand-side building-level water tanks for space heating and cooling, and the community-level central water tanks for heating and cooling. The building-level water tanks are mostly used to reduce the peak power and associated cost in the demand-side. As is seen in Fig. 3, the tanks are connected to the exchangers for space heating or space cooling demand. However, as explained in Appendix A.1, the investment for small-sized tank is relatively high.

By contrast, the central water tanks have lower investment per volume and are more used to interact with the supply side sources, as is seen in Fig. 2. Unlike the other two systems, in 5GDHC system, since the separate heating and cooling networks are aggregated into one looped system, only one central storage tank between the warm and cold pipes is considered. A potential benefit is the internal balancing of heating and cooling demand, which is further explained in Section 5.2.

The general equations for the water tanks are explained in Section 2.1. A time constant of 2 h is applied, which means that the tank can be fully charged or discharged for 2 h. Therefore, the maximum power is specified and is associated with the tank size. The SOC ranges reflect the proportion of the storage capacity that can be used due to water

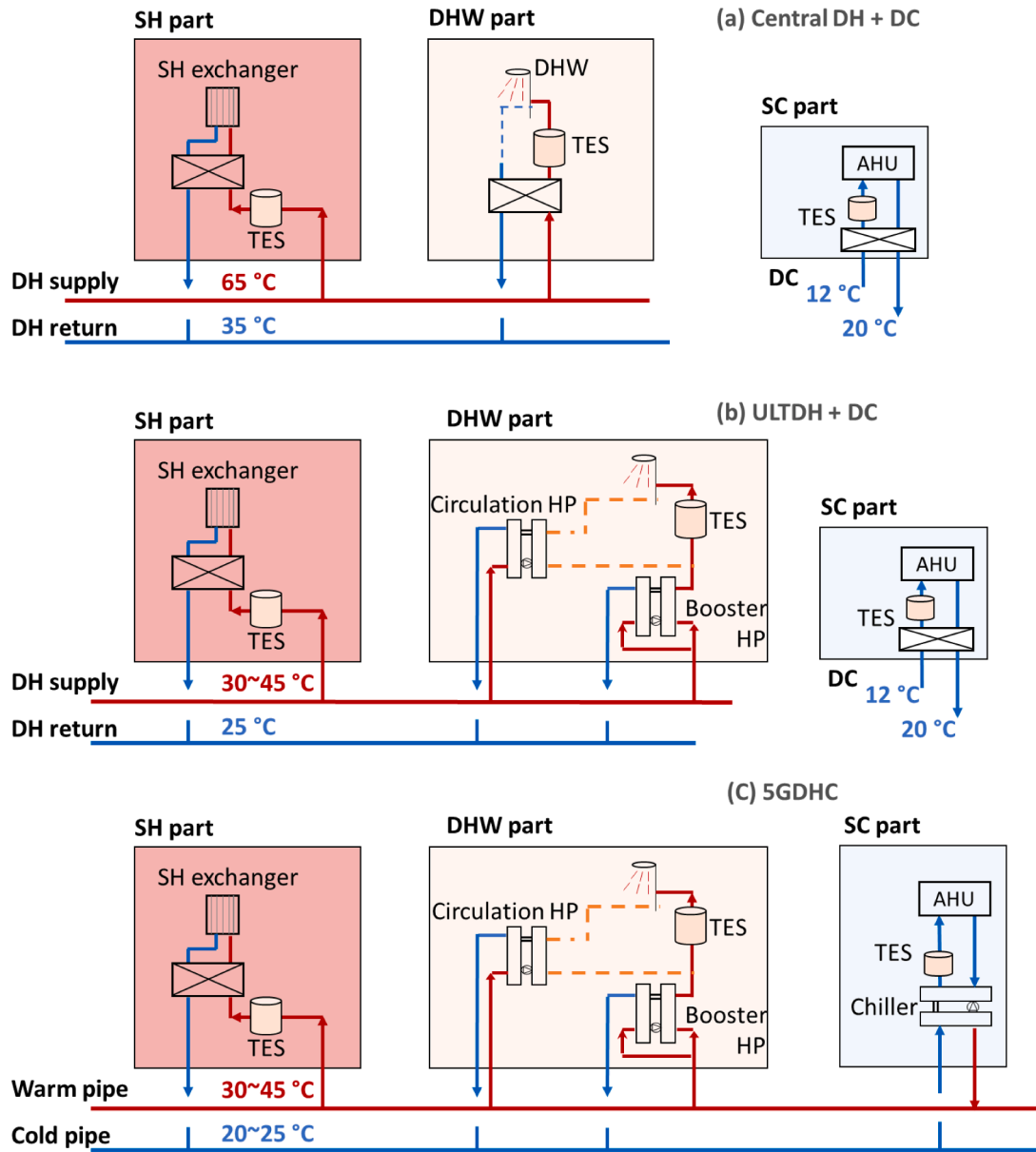

Fig. 3. Typical structures of substations in the central DHC, ULTDH, and 5GDHC systems.

mixtures and temperature level degradation [55]. Based on previous works on thermally stratified tanks [56], it is assumed that 80 % of the storage capacity could be practically utilized. To calculate heat losses, the heat loss rate of $0.6 \text{ W}/(\text{m}^2 \cdot \text{K})$ is applied. The central water tanks are placed outdoors and the small demand-side water tanks are placed in the unheated indoor area such as the warehouse with an environmental temperature of $15 \text{ }^\circ\text{C}$ [57].

Apart from the four investigated types, the DHW tank is also installed to smooth the intermittent demand. An empirical size of 1 L per m^2 of building area is applied due to the low economic incentive for optimizing the DHW tank sizes [44]. This study also considered the use of electric battery as additional storage units in the analysis in Section 5.6. The battery is installed centrally, close to the heat source, and is modelled in the same way as the linearized TES unit. A round-trip efficiency of 90 % and the energy loss rate of $0.2 \text{ } \%/ \text{h}$ are assumed [58]. The shortest length of charging and discharging period is set as 2 h.

2.3. Evaluation index

The levelized cost of energy (LCOE) is calculated to reflect the annualized cost to fulfill unit amount of heating and cooling demand, as written in Eq. (8).

$$\text{LCOE} = \frac{\text{Total annualized cost}}{\text{Total demand}} \quad (8)$$

To evaluate the overall system performance, the energy efficiency ratio (EER) is considered as the ratio between the overall system output and the electricity input. This index reflects the general relationship between the system's input and output, including the auxiliary equipment and heat losses. Thereby, it can be also regarded as the systematic COP from a more classic definition [59].

$$\text{EER} = \frac{\text{Total demand}}{\text{Total electricity consumption}} \quad (9)$$

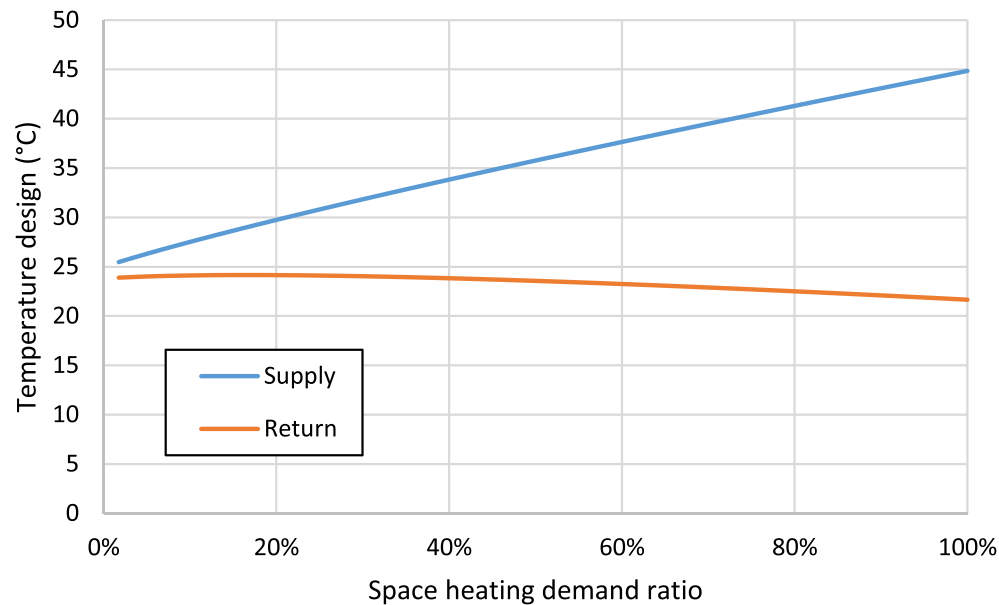

Fig. 4. Relationship between the space heating demand and heating network operating temperatures in the ULTDH and 5GDHC systems, adapted from [62].

3. Case study description

An urban community located in Gothenburg, Sweden, with a total floor area of 24,120 m² is used as the case study, which represents the common small urban district in Sweden. This kind of small community is also regarded as the most promising area for developing the innovative low-temperature DHC systems [5]. For similar cases, the methodology in this study can be also applied to evaluate different energy system options. The multi-family houses (MFHs) and single-family houses (SFHs), with a total floor area of 18,000 m², constitute the majority of the community, as with other residential community in Sweden. The district also has two office buildings and one community supermarket, as shown in Fig. 2.

Table 2 presents the basic parameters about the case buildings and the calculated current heating and cooling demand according to methods explained in Section 2.1. A constant ventilation rate of 0.5 h⁻¹ is assumed in all buildings, which complies fairly with hygienic ventilation rate as specified in the current building code [47]. The energy performance of these buildings are close to the average building stock in Sweden [47]. To assess the future changes, renovations of these buildings are investigated and presented in Section 4.

Three typical DHC systems, as representatives of different transitions towards the future, were modelled and compared in this study. A brief overview of these systems is presented in Table 3. In current conditions, the communities in the city are commonly connected to the central DH and DC systems, provided by the city energy company. As an initiative towards the low-temperature network, the supply and return temperatures for the central DH system are reduced to 65 °C and 35 °C, respectively, considering the difficulty in upgrading large city-level DH systems with no demand-side boosting. For each building, a substation is built to prepare the heating and cooling demand. For SFHs, they are aggregated into two groups with two substations. Inside the substation, the secondary water is heated to the required temperature level by the heat exchanger, as shown in Fig. 3. The space cooling (SC) demand is also prepared by the heat exchanger, using cold water from the DC system. The operating temperatures of the DC system are set as 12 °C and 20 °C, according to the field investigations in Gothenburg [60]. Currently, few residential buildings are connected to the cooling systems due to the very low cooling demand in Nordic countries.

In real DH projects, there are usually more than one heating source

and the prices are most likely different for these sources. To simplify the modelling work, the large and multi-sources city-level DHC systems are represented by one water-source HP and one compression chiller, whose operational costs are close to the average levels of the Gothenburg DHC system [37]. The COP of the HP and chiller is calculated by empirical models based on operating temperatures and thermodynamic efficiency [61], and the detailed parameters are given in Appendix A.1.

The community network has a total length of 1.2 km for DH and 0.6 km for DC (because the cooling is supplied only to commercial buildings), and the pipe sizes are designed according to the maximum flow-rate and allowable pressure drop in the system. For simplicity reasons, the secondary networks inside the buildings are represented by a single pipe with certain transmission heat losses. As can be seen in Fig. 2, several TES options are available, e.g., central and local, and they are explained in Section 2.2.

In accordance with the trend on further lowering the heating water temperature, the second typical system investigated in this study is the combined ULTDH and DC system, noted as ULTDHC. The community network of this system is similar to the central DHC system from Fig. 2. However, the central heating source is replaced by waste-water source HP within the community, with lower forward temperature and higher efficiency. To directly supply the SH with maximum efficiency, the operating temperatures of the heating system are designed by the SH demand ratio, as expressed in Fig. 4. Based on [62], the maximum forward temperature is 45 °C for the radiators and 30 °C for floor-heating systems in the low-energy buildings. To fulfill the temperature requirement of DHW demand, booster HPs, which extract heat from the primary network, are installed in the substations, as shown in Fig. 3. During the low DHW demand period, the hot water circulation to assure satisfying tap-water temperature on-demand could introduce sizable heat losses and increase the return water temperature [63]. Therefore, the circulation HP is installed to cover the heat losses while cooling down the DH water to the design value of 25 °C by the evaporator [64], as shown in Fig. 3. Other decentralized solutions, like the instantaneous heat exchangers, electric tracing system, or micro booster equipment [65], are not considered in this study due to the large uncertainties about the installation process and relative system costs.

With the increase of cooling demand in the future, the 5GDHC system, which allows bi-directional heating and cooling exchange between buildings, is investigated in this study. The separate heating and cooling

Table 4

Basic parameters and the heating and cooling demand of future low-energy buildings. The U-value refers to the average thermal transmittance of the building component.

Building	U-value (W/m ² ·K)			Demand (kWh/m ²)		
	Wall	Window	Roof	SH	DHW	Cooling
MFH	0.35	1	0.25	15.8	14.9	0
SFH	0.3	1	0.2	24.1	18.7	0
Office 1	0.3	1.2	0.25	13.2	2.4	29.3
Supermarket	0.4	1	0.25	15.3	3.3	23.2
Office 2	0.3	1	0.2	14.0	2.0	29.6

networks in the previous two systems are replaced by a bi-directional looped network. Instead of supply and return pipes, the 5GDHC system has a warm and cold pipe, as seen in Fig. 3. For heating demand, the water from the warm pipe is used as heat sources in the SH exchanger or DHW booster HPs. The cooled down water is then discharged into the cold pipe, which can be used as a heat sink for the water-source chillers installed in the commercial and office buildings. The cold-water temperature in the demand side is still set as 12 °C. The heated water from the condenser is in-turn discharged into the warm pipe, which can be used for the heating demand. Detailed descriptions of the 5GDHC system can be found in [14,17,66]. In this study, a fixed temperature difference of 10 K between the warm and cold pipes is applied to simplify the modelling process, while detailed optimization of temperatures can be found in [38]. To directly supply the SH demand, the temperature of the warm pipe is set according to Fig. 4, as explained above. Such fixed temperature design is close to the dynamically optimized temperature in [38]. When the heating and cooling demand cannot be internally balanced, external sources are operated to maintain the network at desired temperatures. The community HP is the same as the ULTDH system. For cooling the water from around 35 °C to 25 °C, natural sources such as lakes or sea are applicable. In the system model, a high COP of around 12 is applied to represent the pumping energy consumption and associated costs, as seen in Appendix A.1.

4. Future scenarios

The renovation plan, climate conditions, electricity prices, and

locally available VRE productions are investigated as the major future changes in this study. These changes were grouped into several scenarios, with which the DHC system transitions were evaluated, reflecting the different pathways towards the future.

4.1. Building renovation

According to the proposal explained in [27], the target demand after renovation is set as around 30 % of the current demand. Major renovation measures include the insulation of exterior building envelope, replacement of low-efficiency windows, installation of ventilation heat recovery systems, and the improvement of air tightness in the buildings [67]. The overall heat transfer coefficient (U-value) and the heating and cooling demand after the renovation are presented in Table 4. In Nordic countries, the cooling demand in commercial buildings is mainly caused by heat gains from internal equipment, human activities, and the solar radiation. Because of the cooler climate, the heat losses through the exterior envelopes and ventilation are positive effects for reducing the cooling demand. Thereby, with the reduction of U-value and SH demand, the SC demand in the office and commercial buildings increases. The average outdoor air temperature in Gothenburg during July and August in 2020 was 16 °C and the maximum temperature was 26 °C. To utilize the free-cooling effect by the cold outdoor air, the ventilation rate is automatically increased to 1 h⁻¹ in commercial buildings when the outdoor air temperature is lower than the indoor air temperature during summer season. It is worth noting that future changes of DHW demand are not considered in this study due to the lack of reliable forecasts of future conditions.

4.2. Climate change

Various models are available for estimating the future climate conditions. This study has used the regional climate model RCA3, created by the Rossby Centre, the climate modelling unit of the Swedish Meteorological Hydrological Institute (SMHI). The regional model with a 50 km horizontal resolution is used to downscale the result of the coarse global climate model ECHAM5. Details about the climate models can be found in [68]. To reflect the future changes of greenhouse gases and aerosols, several scenarios were created by assuming some underlying socio-economic driving forces of emissions, such as future population growth,

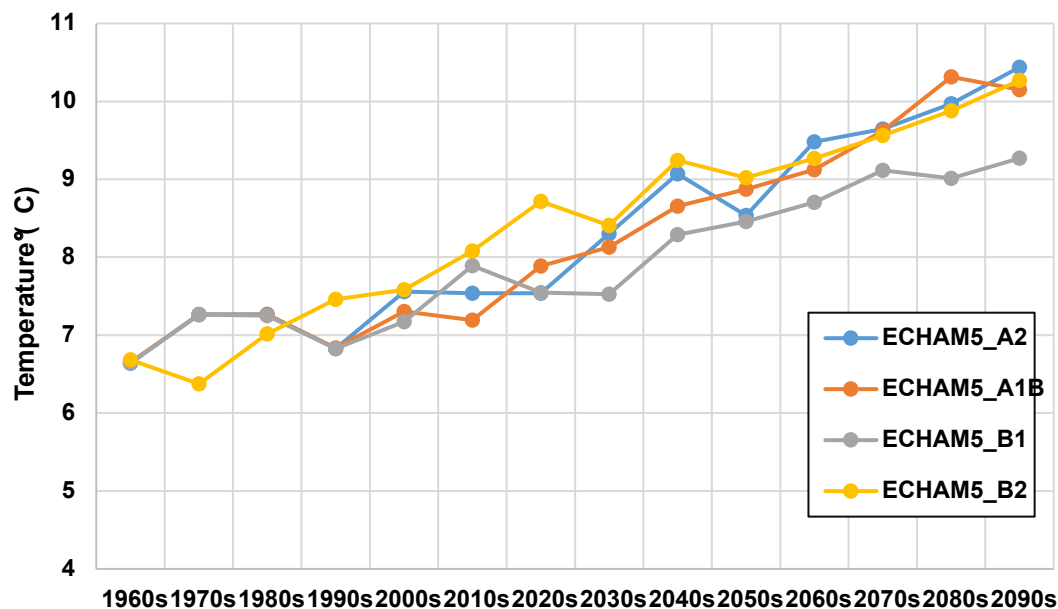

Fig. 5. Average outdoor air temperature during 10-year periods over 1960–2100. ECHAM5 model with four emission scenarios are compared.

Table 5

Temperature profiles and the accumulated demand for the whole community. The calculated cooling demand index refers to the non-residential area (6,120 m²).

Decade	Temperature (°C)			Demand (kWh/m ²)			
	Max	Min	Average	Average building		Low-energy	
				Heating	Cooling	Heating	Cooling
2020s	21.6	-11.1	6.9	88.5	12.4	30.2	27.1
2050s	23.9	-6.1	9.4	69.7	17.1	22.9	31.6

Table 6

Main parameters of the electricity price scenarios.

Name	Wind power usage (TWh)	Nuclear power (GW)	Average price (€/MWh)	Price variations (%)
10 % wind	16	8.5	151.7	8.2 %
20 % wind	33	6	156.8	17.7 %
35 % wind	57	3	139.7	23.8 %
50 % wind no nuclear	82	0	169.9	45.1 %
50 % wind & nuclear	82	3	117.1	8.7 %

economic and technical development. As shown in Fig. 5, the emission scenarios have similar global temperature increase in the upcoming few years but larger differences further in the future. For simplicity, the ECHAM5-A1B climate scenario, which has temperature profiles close to the average level of all models, is used in the upcoming system modelling and evaluations. According to the modelling results, the average temperature in the 2100 s is increased by 3.5 °C compared to the 1960 s level, which is between the temperature increase forecasted by the intermediate and high gas emission scenarios as reported in the latest sixth assessment report of the intergovernmental panel on climate change [69].

The decade of 2050 s is studied as the representative of future checkpoint for reaching the carbon neutrality target [4]. The year 2054, which has an annual average temperature closest to the 10-years average level, is chosen as the representative of the future weather. The current weather condition is represented by the year 2021 from the 2020 s decade. The temperature profiles and the accumulated future heating and cooling demand for the whole community were summarized in Table 5.

It is found that the influence of building renovation is more significant than the influence of the climate change. However, approximately 13 % of heating demand reduction and nearly 50 % of cooling demand increase are observed in 2050 s compared to 2020 s. The results are in agreement with the previous conclusion about more changes in the cooling demand than heating demand in Nordic countries [25]. Such changes will influence the applications of DHC systems. Moreover, with better insulations and lower heat transfer coefficient, the heating demand of low-energy buildings are less influenced by global warming compared to the current buildings.

4.3. Electricity price

The electricity in Sweden is mainly generated from hydropower and nuclear power. In 2020, the shares of hydropower, wind power, and nuclear power in the total national electricity supply are 42 %, 16 %, and 28 %, respectively [70]. As an important measure to achieve carbon neutrality, the electricity generation from VRE is growing fast in recent years. In consequence, the electricity price profiles are influenced. In this study, the variable price profiles are generated by the ELIN-EPOD modelling package [71], which covers the EU-27 countries plus Norway and Switzerland. The model has 50 price areas to represent the European transmission bottlenecks and is capable of analyzing the electricity flows between the areas.

Inspired by an earlier study on the influence of future prices on a city-level DH system [37], five scenarios were created to represent the different integrations of wind power in the Swedish national electricity grid. The variable electricity price is combined with the fixed price decided by the taxes to form the final price. The main parameters of the scenarios are presented in Table 6. The index of price variation expresses the annual proportion of all price differences to the daily average price. A similar variation as in an earlier study about the heat load variations

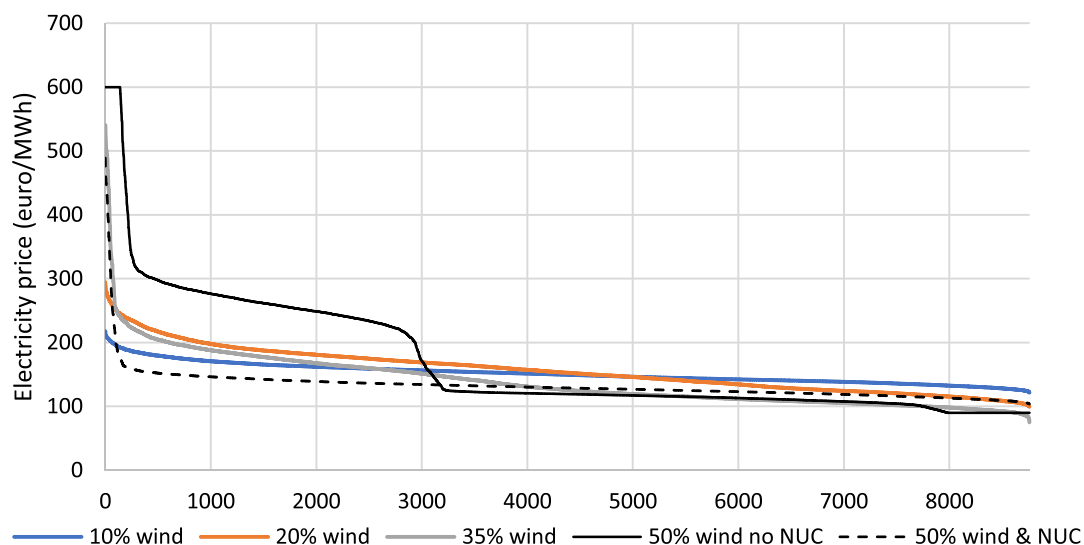

Fig. 6. Duration curves of the five investigated electricity price scenarios. NUC represents nuclear power generation.

Table 7

Main parameters of the local PV scenarios. The direct use of PV electricity by the central DHC system in current condition without any flexibility measure is presented.

Name	Capacity (kW)	Production (MWh)	Direct use, MWh (%)
PV case1	25	25.6	25.1 (98 %)
PV case2	50	51.3	44.1 (86 %)
PV case3	100	102.5	67.7 (66 %)
PV case4	150	153.8	82.8 (54 %)
PV case5	200	205.1	93.7 (46 %)

[72] was chosen. With continuous discussions on the nuclear safety, the nuclear power plant is assumed to be gradually phased-out in the future. One scenario that keeps 3 GW of nuclear power is also considered as an alternative point of view on nuclear as baseload plant. It shall be noted that there are other factors that can influence the electricity prices such as fuel prices. These factors are further discussed in Section 6.

The duration curves of the electricity prices are presented in Fig. 6. With higher integration rate of wind power and phase-out of nuclear power, larger variations are expected to exist, as also reflected in the extreme price conditions. The high electricity price is explained by the limited flexibility in handling intermittent productions from VRE, despite the significant capacity of hydro power in the national grid. Thereby, the expensive CHP plants are more frequently on the margin to compensate the electricity demand that cannot be provided by the renewable energy. On another note, the increasing wind power also brings in lower electricity prices when there is a surplus supply in the system. Comparing the two scenarios that have 50 % of wind integration, the one without nuclear power generation has obviously larger variations and higher average price level. This can also be explained by the frequent ramping of power plants and the limitations in exchanging electricity with other areas.

4.4. Local variable renewable energy

Besides the national grid, the increasing capacity of VRE is also installed in the local district energy system to reduce energy bills and to achieve self-sufficiency. Due to the reduced price of PV panels in recent years, the rooftop PV is an attractive solution for the district energy system and is selected as the local VRE technology in this study. The main parameters of the four investigated PV scenarios are presented in Table 7. Different levels of local PV integration rate are reflected in the

scenarios. Take the example of the central DHC system with current demand profiles, the peak electric power demand is 243 kW and the accumulated annual demand is 646 MWh. The power capacities of local PV in four scenarios cover a range of 10 % to 80 % of the peak power demand. However, due to the imbalance between the supply and demand, only a part of the production can be directly used by DHC system, as is shown in Table 7. To increase the utilization of local PV, the operations of the DHC system as well as the TES units were optimized. In this study, the feed-in price for the surplus PV power is set as a fixed value of 50 €/MWh, which is around 33 % of the average brought-in price from the grid.

5. Results

The Section 5.1 starts with the energy performance and annualized cost breakdown for the three typical DHC systems with current demand profiles and prices, as an introduction to the evaluation works. Then, the influences of demand changes, electricity prices, local PV on the DHC systems as well as the TES applications are explained in Section 5.2–5.4, respectively.

5.1. Performance at current condition

The hourly aggregated heating and cooling demand of the whole community under current scenario is presented in Fig. 7. It can be seen that the cooling demand only plays a very small part of the total demand. Under such scenario, the annual energy supply from central sources and the overall electricity consumption are summarized in Table 8. Due to heat losses in the network, substations and TES units, the central energy supply is larger than the demand, especially in the conventional central DHC system. By contrast, since part of the heating and

Table 8

Annual energy supply from central sources and the overall electricity consumption for three systems under current scenario.

System	Central source supply (MWh)		El consumption (MWh)
	Heating	Cooling	
Central DHC	2,338	87	647
ULTDHC	2,217	85	441
5GDHC	2,134	4	419

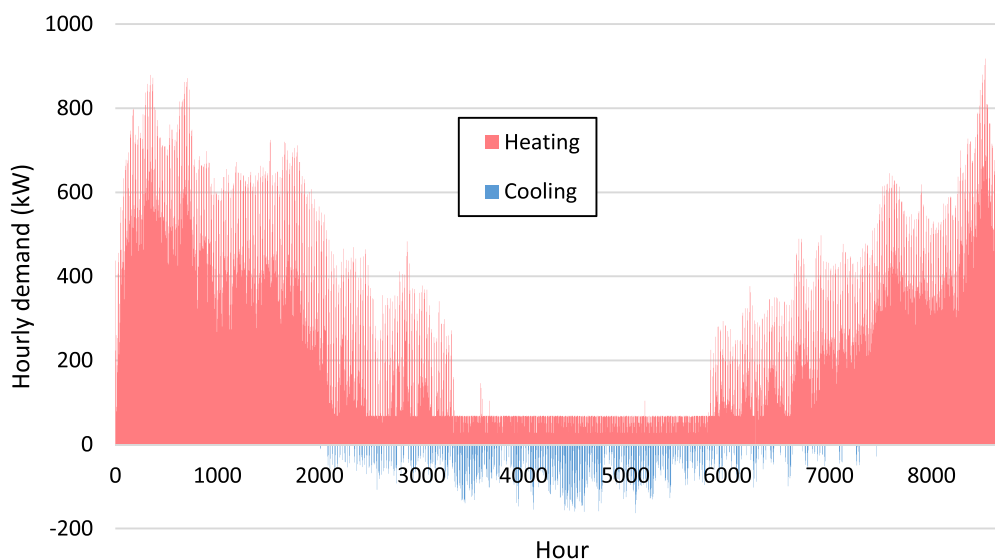

Fig. 7. Aggregated heating and cooling demand of the whole community in current scenario.

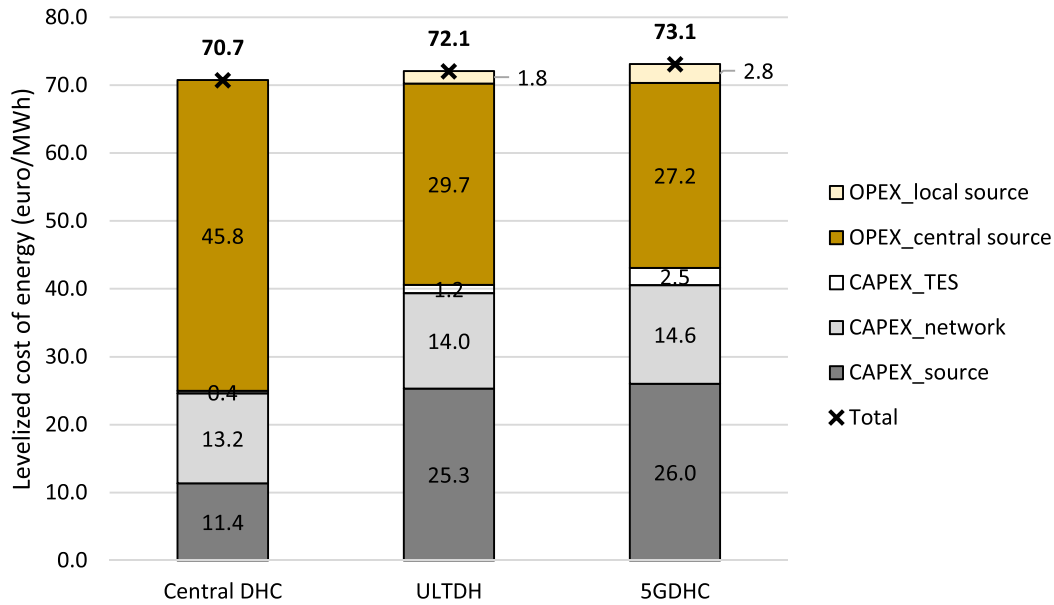

Fig. 8. Breakdown of levelized cost of energy for different systems.

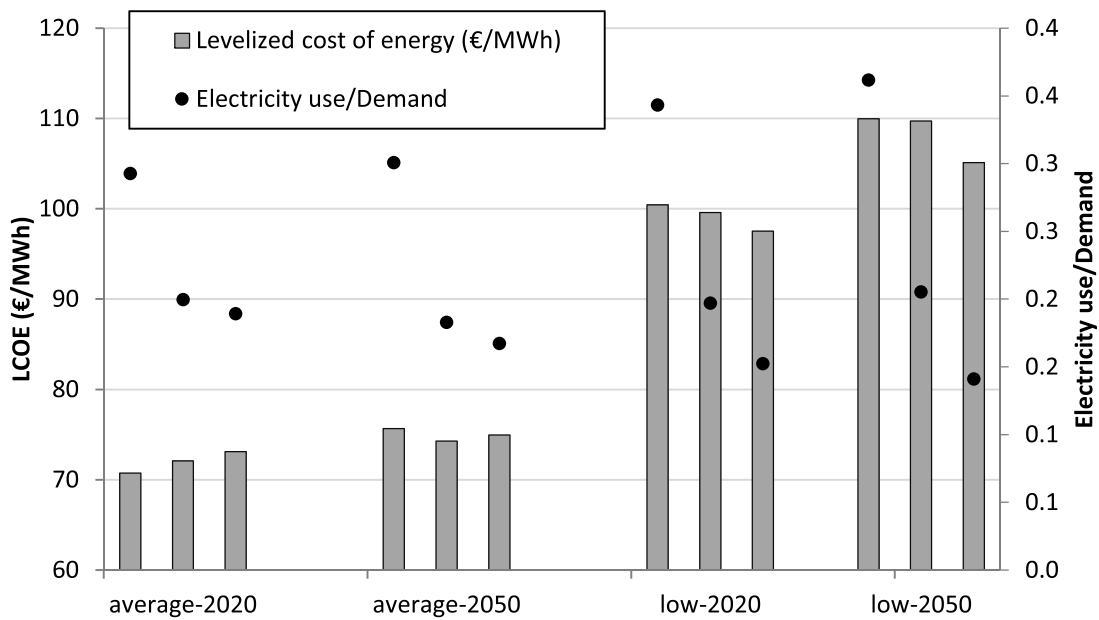

Fig. 9. Levelized cost of energy (LCOE) and electricity use for unit demand under future scenarios. For each scenario, results from the three studied DHC systems, which are the central DHC, ULTDHC, and 5GDHC, are presented from left to right.

cooling demand is balanced internally in 5GDHC system, the external supply is reduced. As the improvement of source efficiency, in ULTDHC and 5GDHC systems, the electricity consumptions are lower than the central DHC system.

Despite the attractiveness in saving electricity consumption, the LCOE for ULTDHC and 5GDHC systems are higher than for the central DHC system, as shown in the cost breakdown analysis in Fig. 8. The main reason is that the increased CAPEX for heating and cooling sources have exceeded the saving of OPEX. Besides, the CAPEX for network is also slightly increased because a larger flowrate is needed, as the temperature difference is reduced in the ULTDHC and 5GDHC systems. Compared to the central DHC system, the OPEX saving in 5GDHC system is relatively small because the waste heat recovery potential from

cooling process is limited. The results under the current scenario proved the economical infeasibility of 5GDHC system for a residential community before the renovation, which is in line with the previous studies [14,66].

5.2. The influence of demand changes

With the demand changes due to the renovations and global warming, the LCOE for the three typical systems are also changed, as presented in Fig. 9. The 5GDHC gradually becomes economically feasible in the future. The LCOE of 5GDHC is 3.4 % higher than central DHC system in current condition and is 4.5 % lower in year 2050 after the building renovation. With larger share of cooling demand in the future, the

Table 9

The share of heating and cooling supply from internal sources in the overall demand under future demand scenarios. Negative value indicates extra supply than the demand, which is thermal loss.

Scenarios	Central DHC	ULTDHC	5GDHC
Average 2020s	-10 %	-4%	3 %
Average 2050s	-12 %	-5%	7 %
Low-energy 2020s	-25 %	-10 %	23 %
Low-energy 2050s	-30 %	-10 %	33 %

Table 10

Energy efficiencies of the ULTDHC system under future demand changes.

Scenarios	System EER	HP COP	
		Central HP	DHW booster HP
Average 2020s	5.0	5.7	5.6
Average 2050s	5.2	6.5	
Low-energy 2020s	5.1	7.8	
Low-energy 2050s	4.9	8.8	

5GDHC system uses less electricity compared to central DHC system. For ULTDHC system, it has similar LCOE with the other two systems in the current average building stock. However, after the building renovation, it is not as attractive as 5GDHC in the future. These findings about the future trends are explained from several aspects including the system structures, source efficiency, and system losses.

With more simultaneous heating and cooling demands in the future and higher shares of each, the related energy demands can be supplied from high-efficiency internal sources in the 5GDHC system, as shown in Table 9. For low-energy buildings in 2050, the central sources only contribute to 67 % of the overall demand, which is mostly occurring in winter. By contrast, with the heat and cold losses included, more energy is supplied than the actual demand in the central DHC and ULTDHC systems, as shown by negative values in Table 9. In general, the heat losses are becoming more significant with the reduction of SH demand in the future. The main causes are the network transmission losses and the circulation losses inside the substation. Compared to the central DHC system, with a lower supply water temperature of around 35 °C, the share of heat losses is reduced to around 10 % in ULTDHC and 5GDHC systems. Besides, these losses are less critical because they are mostly supplied by circulation HPs and low-temperature central HPs, which have higher efficiencies than the sources in the central DHC. The heat losses in 5GDHC system are around 8 %, i.e., lower than in the ULTDHC system. The main reason is the reduction of cooling losses since the cooling networks are aggregated into one looped system that has an operating temperature close to the ground, as of around 20 °C. By contrast, in the ULTDHC system where the forward temperature from the central DC system is 12 °C, the temperature difference of 8 °C between the cooling pipe and shallow ground drives the cooling loss.

As for the source efficiency, the COPs of the central DH and DC sources remain at 3.78 and 3.06, respectively, under the future demand scenarios, due to unchanged heating and cooling network operating temperatures. The latter are decided by the requirement for hygienic DHW and cooling supply, as explained in Section 2. For ULTDHC and 5GDHC systems, the heating supply temperatures are lower, and the central COP is therefore higher. As shown in Fig. 3, with lower SH demand in the future, the supply water temperature in these systems can be further reduced from 45 °C in the radiator system to 30 °C in the floor heating system. Therefore, for the considered water-source HP, the lifting temperature is lower, and the COP is increased from 5.7 in the current condition to 9.4 in the low-energy scenario with 2050 s climate profiles.

As for the local chiller that is installed in the 5GDHC system to provide cooling to the buildings, the condensing temperature is based on the temperatures in the warm pipe, which is also reduced in the future.

Therefore, the COP of the local chiller is also increased, from 5.8 in the current to 7.8 in the low-energy scenarios. The overall EER of the 5GDHC system reached 7.1 in the low-energy buildings in 2050, which is significantly higher than that of 4.9 and 2.8 in the ULTDHC and central DHC systems, respectively.

Despite the improvement of heat source efficiency, the ULTDHC system is not as economically attractive as 5GDHC in the future, as shown in Fig. 9. This phenomenon is explained from several points of view. First, with the reduction of SH demand, the direct use of the high-efficiency community HP is reduced along with its economic benefits. Second, the costs for supplying DHW increases due to the additional heat supply. In such system, the cold tap water of 10 °C is firstly heated up to around 35 °C by the central DH through the heat exchangers. Then, to boost the pre-heated water to the required hygienic temperature level for DHW, a part of the hot water from the central network is used again as a heat source in the booster HP, as shown in the typical substation structure in Fig. 2. Therefore, the overall heat supply from the central and booster HPs is larger than the actual demand. With a lower forward temperature, the heat from the central high-efficiency HP is reduced and a larger use of the booster is required. Thereby, despite the increase of COP for the central source, the overall system EER is still reduced in the future, as shown in Table 10. As pointed out in the previous research work [13], the ULTDHC system is more suitable for an area with high SH demand density, such as those with a plot ratio higher than 1 and SH share higher than 70 %. The highest system EER in the average building scenario in 2050 s also indicates an economically optimal forward temperature of 40 °C for the studied case.

Compared to ULTDHC and central DHC systems, there is more need for central storage units in the 5GDHC system as shown by the optimal storage sizes in Fig. 10. Unlike the former two systems, only one community-level water tank is used in the 5GDHC system for balancing the heating and cooling sector. The storage temperature range is defined by the operating temperatures of the warm and cold pipes. The benefits from the storage unit can be classified into three major points: 1) reduced peak power; 2) increased internal balance of heating and cooling demand, as well as reduced energy supply from central sources; 3) better utilization of the variable electricity prices and, consequently, reduced operating costs. The second benefit is especially important for the 5GDHC system to maximize its efficiency. For the investigated future low-energy community, around 10 % of the total demand, as introduced in Table 9, is internally balanced via the use of the central TES.

For ULTDHC system, the large CAPEX associated with the heating sources and peak shaving potentials is the main incentive for the use of central TES. Therefore, in the average building stock, the optimal sizes of TES together are larger than that in the central DHC system. However, with the reduction of SH demand and heat supply temperature, the sensible storage capacity of the hot water tank is directly reduced. With limited benefit, the optimal size of central TES in ULTDHC system becomes smaller in the future. For the central DHC system, the optimal TES is slightly increased in the future to shave the peak demands. Indeed, greater peak-average difference and greater peak shaving potentials can be expected [25].

For the cold water storage, the temperature difference is the same as the DC network temperature difference, which is 8 °C. As explained above, there is no need for a community-level cold water tank in the 5GDHC system. For central DHC and ULTDHC systems, as the cooling demand becomes larger in the future, the need for cold storage also increases. The optimal size in the future is around 8 m³, which is still relatively small compared to the hot water tank.

Due to the relatively high investment associated with small-scale water tanks, the total size of the building-level TES units in the whole community is only 4 m³, which is around 0.15 L per unit building floor area. The building-level TES is mainly used as buffer unit to shave the peak demand and reduce the equipment cost. Such conclusion is in line with the previous findings about the applicability of demand-side TES [44].

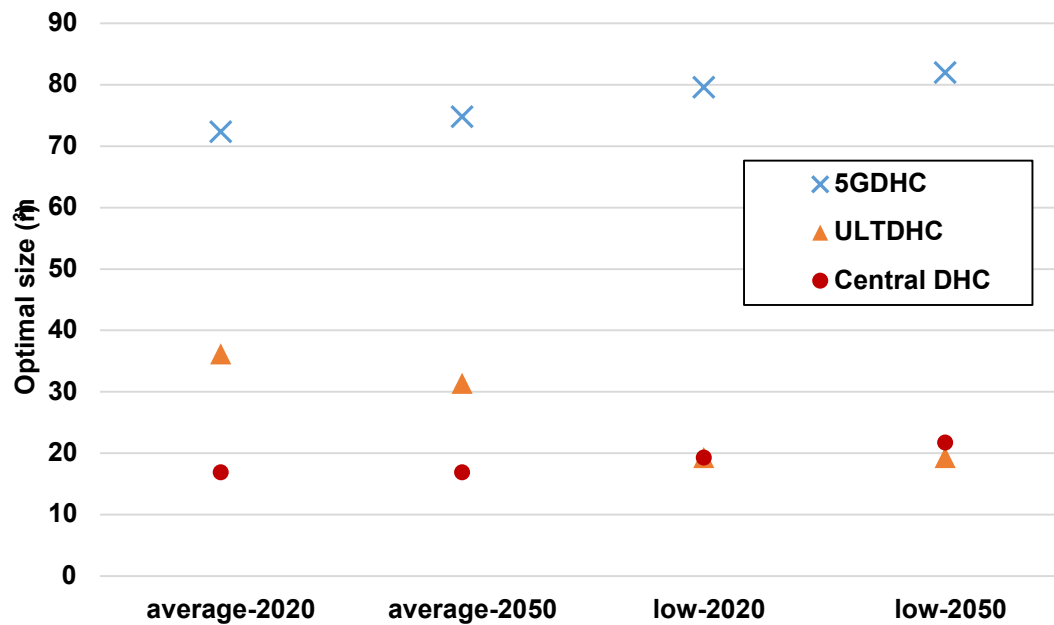

Fig. 10. Optimal community-level hot water tank sizes in different systems.

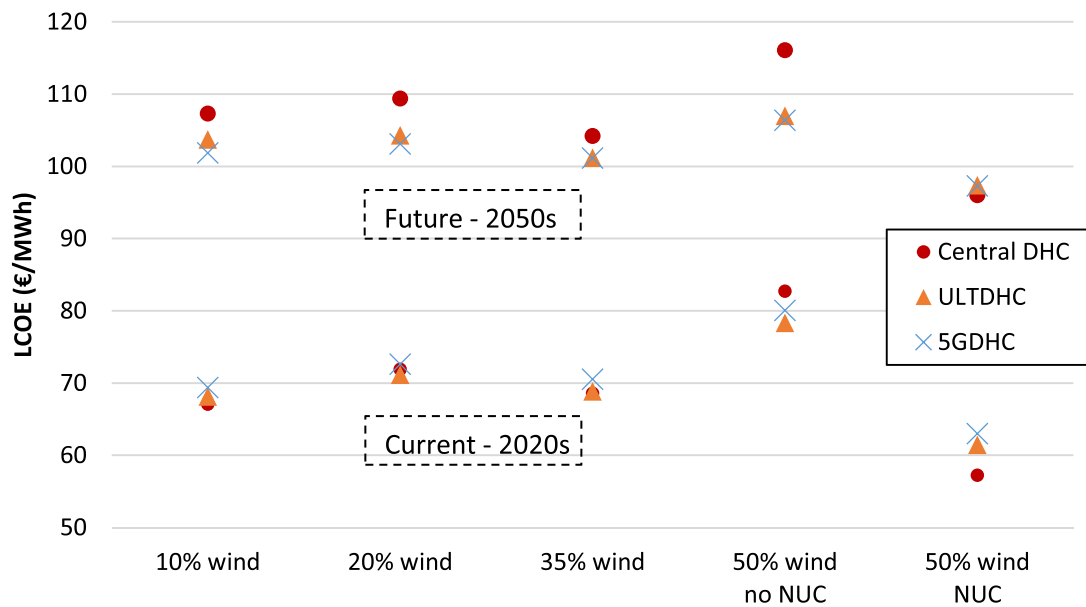

Fig. 11. LCOE of the three studied DHC systems under different future price scenarios.

5.3. The influence of electricity prices

The influence of future electricity prices on the systems annualized costs is shown in Fig. 11. Two demand profiles from Section 5.2, which are for the current buildings in 2020 s and for the low-energy buildings in 2050 s, were also included in the analysis. As explained in Section 5.2, the 5GDHC and ULTDHC systems are in general economically infeasible with the current demand profiles but become cost-saving with the future demand profiles. However, in the future, with 50 % wind power and nuclear power in the national grid, the 5GDHC is even costing more than the central DHC system.

The main change is in the OPEX, which is directly influenced by the electricity prices. As shown in Table 6, the annual average electricity

price is 52.8 €/MWh lower if the nuclear plants remain in the national grid. These plants can serve as baseload power plants, so the expensive fossil-fuel based plants are less operated when there is scarcity of wind power. As shown in Fig. 12, with nuclear plants and lower average electricity prices, the share of OPEX becomes smaller. The benefits of 5GDHC system for lowering the OPEX are also reduced, which cannot offset the relatively expensive capital cost.

Comparing the five electricity price scenarios, the 50 % wind without nuclear scenario has the highest average price and the largest share of OPEX. Therefore, such scenario is favorable for the applications of OPEX-saving systems. Under current demand profiles, it even makes the 5GDHC and ULTDHC systems more cost-effective than the central DHC system.

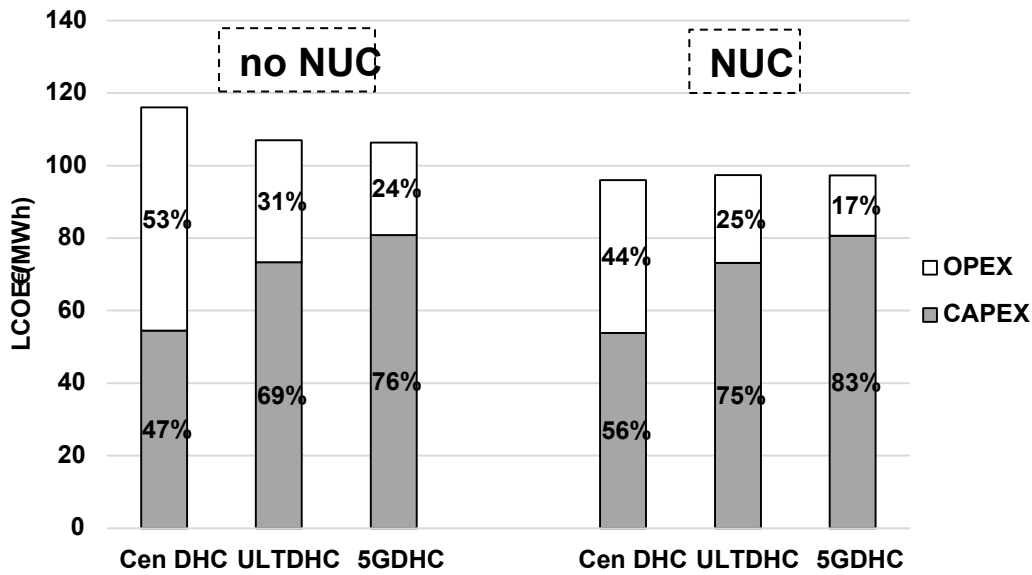

Fig. 12. The distribution of CAPEX and OPEX under 50% wind power scenarios with low-energy demand profiles.

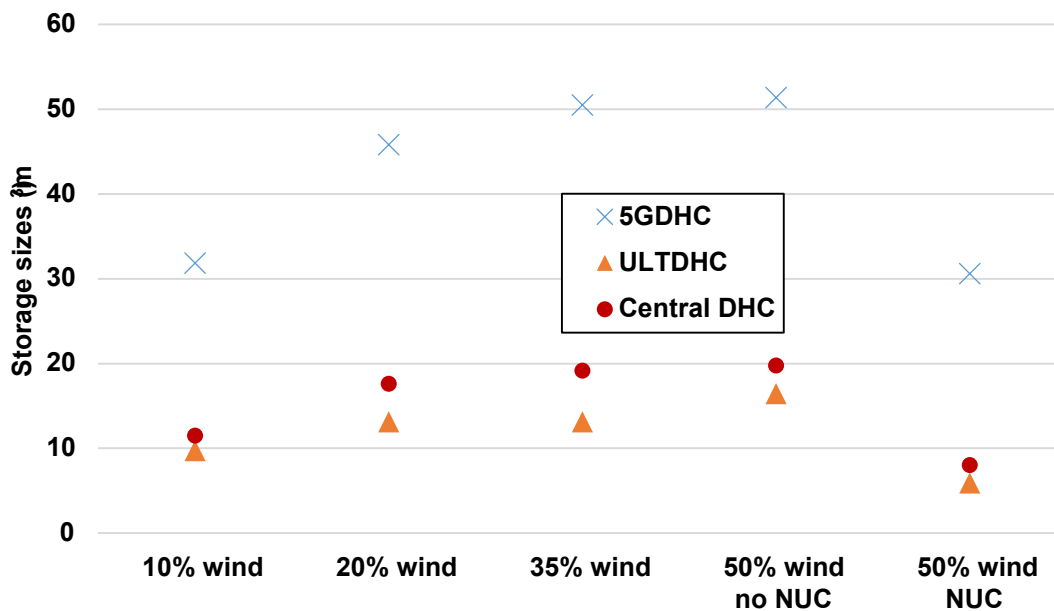

Fig. 13. Optimal community-level hot water tank sizes under different price scenarios with future low-energy demand profiles.

Another factor contributing to the difference of OPEX is the distribution of electricity prices. In summer, the wind power has stronger output due to the weather conditions in Nordic countries, making the electricity prices generally lower compared to winter. With the nuclear plants in the grid, the wind power is on the margin for most of the time during summer. Although the cooling demand makes up to 27 % of the total demand, the OPEX between May and August is only 15 % of the total OPEX. Therefore, the main advantage of the 5GDHC system at low operational costs during summer is again weakened.

As for the applications of TES units under future price changes, the demand-side water tanks have similar small sizes as in the scenarios in Section 5.2, due to the relatively high investments associated with them. Compared to the community-level cold water storage, the central hot water tank has much larger optimal size because the heating demand is

still dominant in the district. With the increase of wind power penetration rate and the increase of consequent price variations, there is stronger need for the community-level hot water tank, as shown by the increase of optimal size in Fig. 13. As for the nuclear scenario with the lowest average price and smallest price variations, the optimal size of the TES is also the smallest. It is worth mentioning that the differences of sizes in terms of DHC systems are in line with the previous results in Fig. 10.

To better understand the benefits of TES units, the cost-saving breakdown analysis was conducted on the hot water tanks under two price scenarios, as shown in Fig. 14. The hot water tank is mainly used to take advantages of the variable electricity prices in the central DHC system. In the ULTDHC and 5GDHC systems, the most benefit comes from the reduction of peak power in the expensive heating and cooling

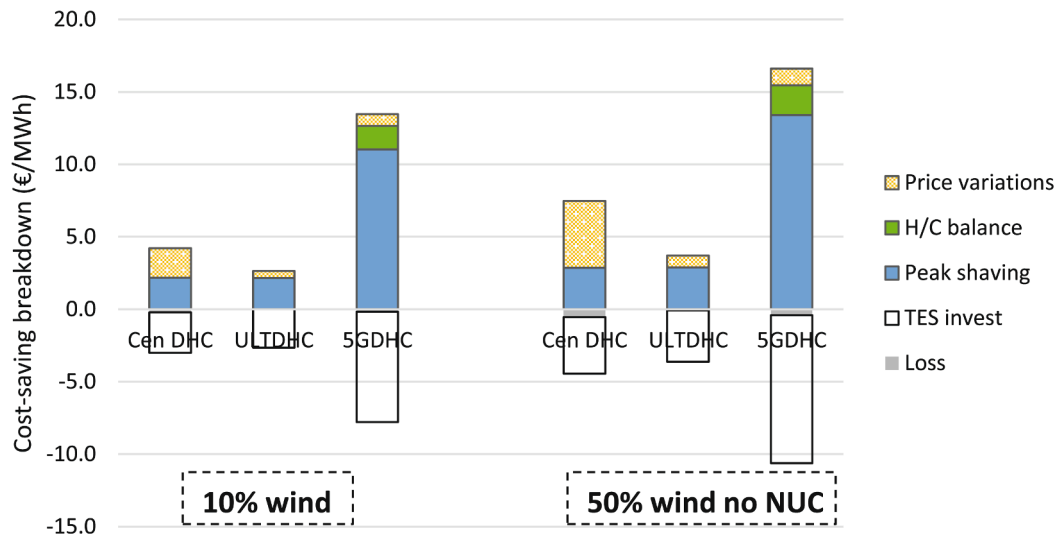

Fig. 14. Cost-saving breakdown of TES units under two price scenarios with future low-energy demand profiles.

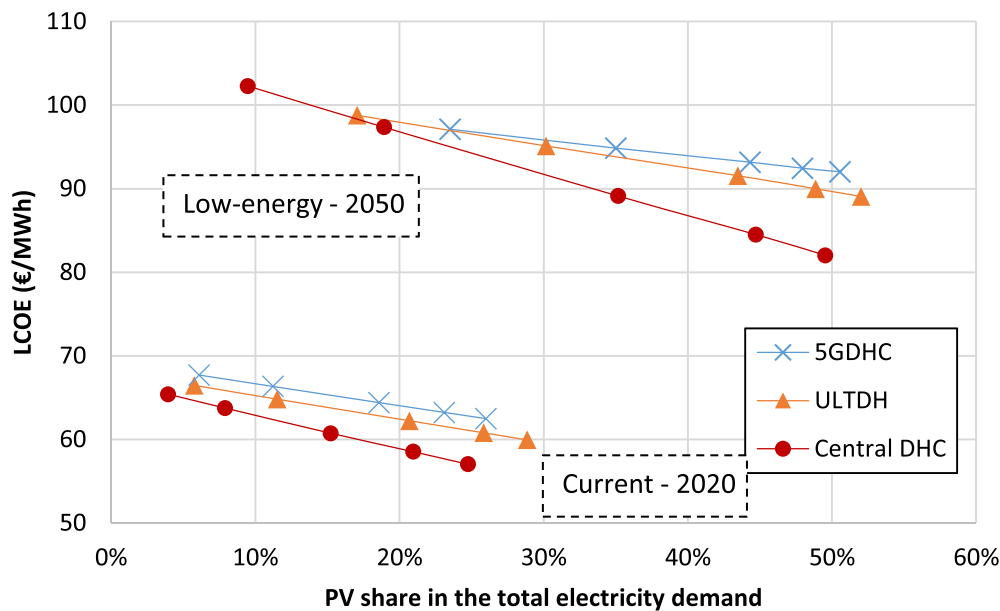

Fig. 15. LCOE and the share of PV usage in the total electricity demand. Each dot represents one local PV case.

Table 11

Heating, cooling, and electricity demand for three systems with future low-energy demand profiles.

Systems	Heating (MWh)	Cooling (MWh)	Electricity (MWh)
Central DHC	552	193	272
ULTDHC			148
5GDHC			104

equipment. In the ULTDHC system, the benefits are limited due to the small storage density and system characteristics, as explained in Section 5.2. The relatively high heat-to-power ratio in the 5GDHC system, which makes the synergy between heat and electricity less feasible, is another reason behind the limited benefits from electricity price variations. More details are explained in Section 5.4 with local PV power.

5.4. The influence of local PV

With different installed capacities of PV panels in the district, the contributions of PV power to the electricity demand and the LCOE of the three DHC systems are shown in Fig. 15. The analysis within this section is based on the 10 % wind electricity price pattern, to exclude the disturbance of other factors. In general, as the demand is reduced in the future, the share of PV power in all three systems is higher than that with the current demand profiles. Speaking about the difference between the systems, the 5GDHC is cost-saving only when there is a small share of local PVs, as pointed out in the upper left part of Fig. 15. As the capacity of PV increases, the LCOE reduction benefit in the 5GDHC system is much smaller than the reduction in the central DHC system. In other words, to reach the similar PV integration target larger than 20 %, the 5GDHC costs more than the other two systems.

An important reason for this outcome is the electricity demand profile. Indeed, the 5GDHC is consuming only around half of the central

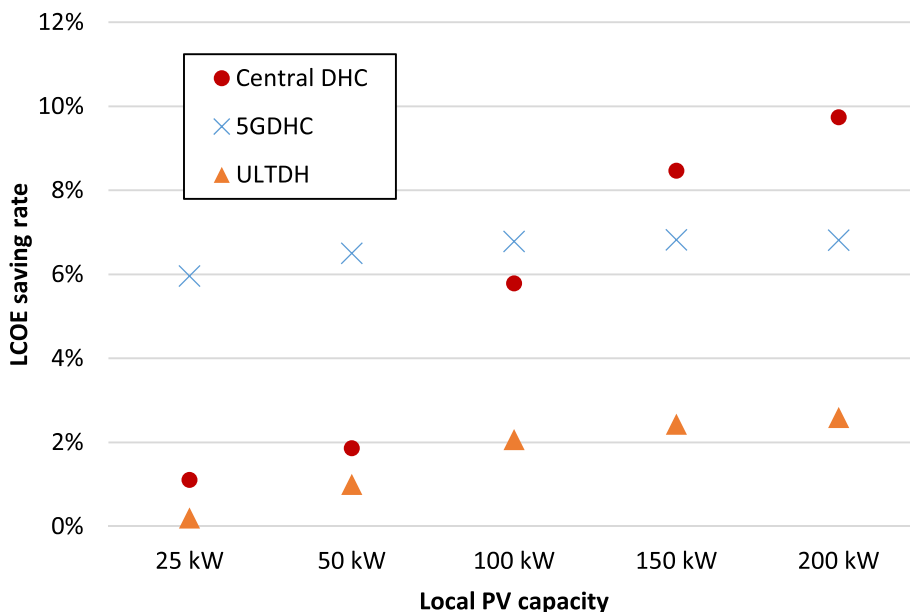

Fig. 16. LCOE saving benefit by the TES units in three studied DHC systems with low-energy demand profiles.

Table 12

Overview of the main changes in demand side and supply side in the future.

Name	Description
Change 1: demand	Low-energy demand profile and future climate in 2050
Change 2: price	50 % wind scenario without nuclear plant. Average price: 169.9 €/MWh
Change 2*: price	50 % wind scenario with nuclear plant. Average price: 117.1 €/MWh
Change 3: local VRE	PV with 150 kW capacity

DHC system’s electricity demand, as presented in Table 11. Although the PV integration target is not favorable, the realistic electricity consumption of 5GDHC is still the smallest. From another perspective, to balance the supply and demand, the small demand profile only favors a small capacity of local PV. Otherwise, the surplus power is sold back to

Table 13

The battery sizes and future changes for the analysis of battery applications.

Item	Description
Battery sizes	0–500 kWh
Future changes	Low-energy demand profile, 50 % wind electricity price scenario with nuclear plant, local PV capacities of 150 kW to 250 kW

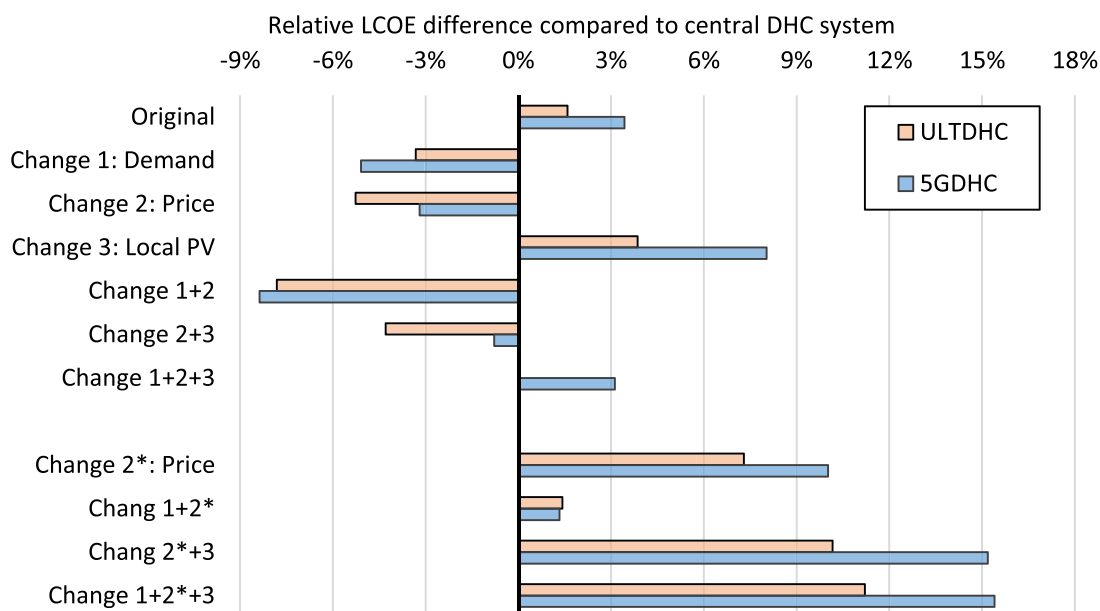

Fig. 17. Relative LCOE differences compared to the central DHC system under future changes.

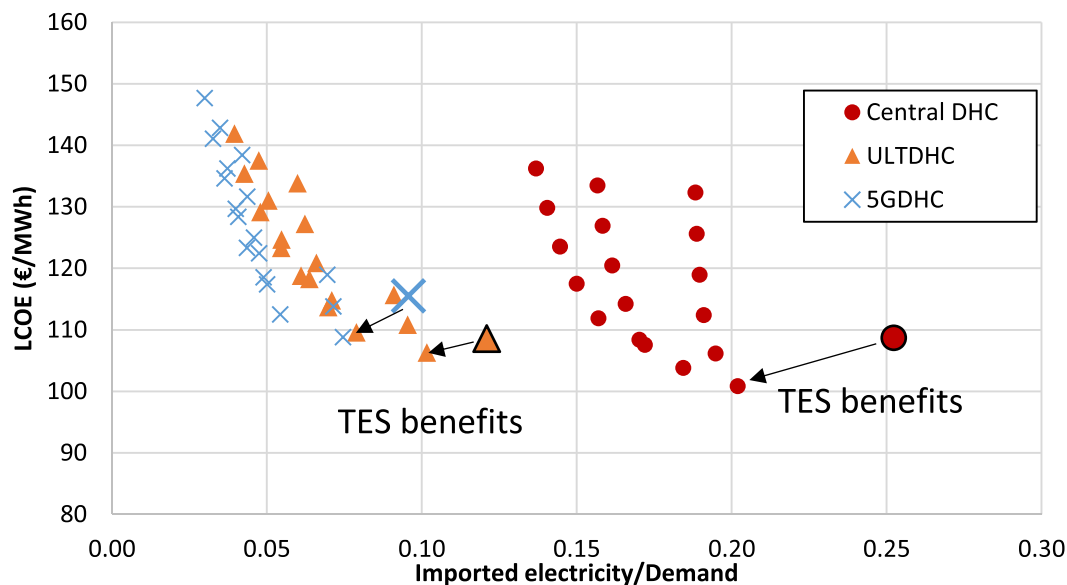

Fig. 18. LCOE and imported electricity for the three systems with different sizes of battery under future changes. The enlarged markers represent the reference scenarios without any storage unit. The arrows represent the TES benefits.

the grid at a low price, which influences the economic performance of the whole system. Meanwhile, with the integration of PV, the average electricity price becomes smaller, which again reduces the advantage of 5GDHC system as explained in Section 5.3.

The limited application of TES to achieve the synergy between the heat and electricity is another reason for the 5GDHC system performance. As presented in Section 5.2, the overall EER of the 5GDHC system is 7.1, which is much higher than 2.8 of the central DHC system. That is, with the same TES capacity, the shifted electricity in the 5GDHC system is only 2.8/7.1 of the central DHC system. Therefore, the application of TES in the 5GDHC system is limited when there is a strong need for the synergy between heating and electricity, as shown by the cost-saving benefits of TES under different local PV scenarios in Fig. 16. In contrast, larger capacities of the local PVs provide additional benefits to the central DHC system. The cost-saving breakdown analysis in Fig. 14 also reveals that the main benefit of TES in 5GDHC system comes from thermal-only application and not from thermal-electricity application such as variable prices or PV integration.

5.5. Summary of future changes

Based on the individual influence of each future change in the previous sections, the combined influences of demand side and supply side changes are discussed hereafter. Table 12 presents an overview of the major changes in the future. Among these changes, the future development of local VRE is hard to be anticipated because it is influenced by many factors such as the facility investment, feed-in tariff, and carbon taxes. For the analysis in this section, the PV case with an installed capacity of 150 kW is used as an example of relative rapid development of local VRE.

For ULTDHC and 5GDHC systems, the relative differences of LCOE compared to the central DHC system are shown in Fig. 17. It is seen that the combined influence of future changes is close to the cumulative summary of single changes. The changes with numbers 1 and 2, i.e., the demand reduction and higher electricity price, favor the application of ULTDHC and 5GDHC systems. In contrary, the lower electricity price and larger share of local VRE (number 3) inhibit the two systems. As a result, the LCOE in the three systems is quite different with all changes considered.

To make the 5GDHC system economically attractive, the annualized

cost of the whole system shall be reduced by 3 €/MWh and 12 €/MWh respectively, in the future scenarios with high and low average electricity prices. Considering 2,000 h of full-load performance on average, the cost reduction targets correspond to 6 €/kW and 24 €/kW of annualized capital investment respectively. However, despite the economic difference, the ULTDHC and 5GDHC systems still have much lower electricity use.

5.6. Applications of battery storage

The results and analysis in Section 5.4 have shown the limited benefits of TES in achieving the heating and electricity synergy in 5GDHC. Here, batteries as energy storage units, which can directly shift the electricity demand, are investigated to increase the VRE integration level. The applications of battery are considered under a set of future changes, as summarized in Table 13. As it can be seen, under all future scenarios, the use of battery is economically infeasible due to the relatively high investment of today. The conclusion is in line with a previous study on the optimal design of battery in DHC systems [58]. On another note, considering the future development of battery technologies and possible lower production prices, the application of battery in the DHC system requires further notice, which is outside the scope of this work.

To explain the performance of the battery, its various sizes were considered in the three DHC systems. The LCOE and electricity consumptions of these systems are shown in Fig. 18, along with the benefits of the associated TES units. It is clearly seen that the benefit of TES in 5GDHC is limited, as explained in the previous sections. The scenarios with installed batteries are represented by smaller markers in the figure, which all have higher LCOE than the scenarios without batteries (enlarged single markers). Obviously, with batteries, the imported electricity can be reduced to as low as 0.03 kWh per unit heating and cooling demand, giving an overall EER of 33. The target of a self-sufficient district, or near zero-energy district, can be thus achieved. In conclusion, the results about the TES and battery combined prove the need of flexible and cost-saving energy storage solutions in the future systems characterized by high heating efficiency and high heat-to-power ratio.

Other than the target of VRE integration rate used in Fig. 15 for the systems' comparison, another perspective from practical electricity use is provided in Fig. 18. The 5GDHC and ULTDHC systems have much lower electricity use than the central DHC system. Thereby, the optimal

system choice is not a fixed result but shall more dynamic according to the design targets and objectives.

6. Discussion

This study explored the possibilities of future changes of heating and cooling demand in buildings and evaluated the system transitions and the applications of TES under these changes. It shall be noted that the transitions are planned for a newly built area, i.e., the investment for the entire network is considered in all scenarios. Therefore, the comparison between the systems is based on the same boundary condition to avoid biased conclusions. The upgrading of an existing network to possible ULTDHC or 5GDHC systems is not considered due to the large uncertainties about the practical project cost.

Based on the results, the ULTDHC is proven to be less economically feasible than the 5GDHC with the future demand changes. Indeed, the ULTDHC is a combined centralized and decentralized system. As the demand density reduces, the benefit from the centralized part reduces as well, while more extra energy is required in the decentralized sources, as explained in Section 5.2. This conclusion is in line with the previous works on the relationship between demand density and system feasibility [13]. The understanding is enriched with the results from the 5GDHC system, which has more benefits in the decentralized sources with future changes. However, it shall be noted that the fully decentralized heating and cooling systems for buildings are not considered in this study due to the large uncertainties associated with the implementations and costs.

In the supply side, the future electricity prices due to the integration of wind power and the probable phase-out of nuclear plants are also investigated. It shall be noted that the future prices are sensitive to many possible factors such as the fuel prices, VRE profiles, power transmission networks between countries, and even political issues. Based on the results in this study, the changes in prices can be described by the following key indices: the average price level, variations, and seasonal distributions. The ULTDHC and 5GDHC are more economically feasible under conditions with high average price and high summer price. To quantitatively capture the influence of the above-mentioned factors, the national electricity grid model shall be improved, which in turn requires comprehensive multi-scenarios analysis in the future. Meanwhile, the TES units were proven to be less applicable for the synergy between heating and electricity in the future when the overall system efficiency and heat-to-power ratio are improved. Flexible and economic energy storage technologies are also needed.

The reference monetary values used in the evaluations are based on previous projects and market prices, which are reasonable for the selected small case community. However, it shall be noted that the changes of economic parameters can directly influence the results. E.g., in some area of Gothenburg, the cost of peak power is nearly 80 €/kW including the network cost. Such a power cost will introduce more benefits for peak-shaving TES units and even change the optimal system design. The focus of this study is the influence of future changes, and the major conclusion is about the transitions of system and TES applications. Yet, the resilience about such performance and the sensitivity of economic parameters requires further investigations [11], to comprehensively understand the transitions in the future.

In the investigated residential community, the heating demand is still dominant, making up to 73 % of the total demand even in the low-energy buildings in the 2050 s. There is a small potential of utilizing waste heat during summer and, thus, little incentives for using the seasonal storage. Thereby, the seasonal TES is not considered in this study. Besides, the considered TES technologies are based on sensible storage. With the reduction of operating temperature difference, the latent storage with phase change material could have more potentials. However, the practical issues such as the low discharging power, sub-cooling phenomenon, and the low economic feasibility shall be carefully considered [73].

7. Conclusions

This study aims at elucidating the transition of DHC systems and roles of TES under the future possible changes, induced by climate changes, building renovations, electricity prices, and local VRE productions. The changes were analyzed and aggregated into several scenarios. Based on a case residential community, three studied systems including the central DHC, ULTDHC, and 5GDHC were simulated and compared in terms of the energy performance, LCOE, and imported electricity. The results from multi-scenarios were analyzed and the key conclusions are summarized as follows:

- 1) In the case residential community where the cooling demand stands for only 3 % of the total demand, the future warmer climate until the 2050s and deep building renovations would increase the cooling share to 27 %. In the considered demand change, the 5GDHC system, which currently has the highest system cost, becomes economically feasible. This brings new insights on the applications of 5GDHC in residential communities.
- 2) The increasing production of wind power and probable phase-out of nuclear power have significant influences on the national electricity prices. Without nuclear plants, the prices would be higher on average and with larger variations, which increases the OPEX and makes 5GDHC and ULTDHC more cost-saving compared to the central DHC system. The increasing energy prices create more possibilities for new technologies.
- 3) With the power production from local PV, the 5GDHC system has higher LCOE than the other two systems if the similar PV integration target is applied. The main reasons are the low electricity demand profile, limited use of TES, and the reduced average electricity price. As the overall system efficiency and the heat-to-power ratio are improved, the active shift of electricity demand by using TES is less applicable. However, the 5GDHC system still has the smallest electricity consumption among the three DHC systems.
- 4) The combined changes in the supply and demand side would have significant influences on the LCOE difference between the considered DHC systems. To make the 5GDHC system economically attractive, the annualized capital investment of the whole system shall be reduced by 6 €/kW and 24 €/kW in the future scenarios with high and low average electricity prices, respectively. This calls for multiple improvements in equipment production, installations, and business models.

CRedit authorship contribution statement

Yichi Zhang: Methodology, Validation, Investigation, Formal analysis, Writing – original draft. **Pär Johansson:** Conceptualization, Writing – review & editing, Supervision. **Angela Sasic Kalagasidis:** Conceptualization, Resources, Writing – review & editing, Supervision.

Declaration of Competing Interest

The authors declare that they have no known competing financial interests or personal relationships that could have appeared to influence the work reported in this paper.

Data availability

The data that has been used is confidential.

Acknowledgement

This work was supported by the Swedish Research Council for Environment, Agricultural Sciences and Spatial Planning (FORMAS) [Grant No. 2018-01228]. The authors also thank the Chalmers Energy Area of Advance, Profile area: Energy in Urban Development for the

additional financial support.

Appendix A

Appendix A.1 Heating and cooling source parameters

The COP of HPs and compression chillers are modeled with the condensing temperature, evaporating temperature, and thermodynamic efficiency for compressor η_c [61]. The pinch point temperature difference for heat exchange between the water and the refrigerant is set as 2 K. The parameters of the heating and cooling sources in central DHC, ULTDHC, and 5GDHC systems are presented in Tables A.1–A.3, respectively. As is explained in Section 2, the complex heating and cooling sources in Gothenburg are represented by one HP and one compression chiller, presented in Table A.1. Considering an average electricity prices of 0.16 €/kWh, the average heating and cooling prices are 0.042 €/kWh and 0.052 €/kWh, respectively, which are close to the energy prices in Gothenburg [74].

Table A1

Parameters of heating and cooling sources in the central DHC system.

	Outflow temperature		η_c	Nominal COP
	Evaporator	Condenser		
City DH	15	65	0.6	3.78
City DC	12	38	0.4	3.06

Table A2

Parameters of heating and cooling sources in the ULTDHC system.

	Outflow temperature		η_c	Nominal COP
	Evaporator	Condenser		
Community HP	15	35	0.6	7.75
City DC	12	38	0.4	3.06
DHW booster HP	25	55	0.6	5.82
DHW circulation HP	25	55	0.6	5.82

Table A3

Parameters of cooling sources in the 5GDHC system. The heating sources are the same as in the ULTDHC system.

	Outflow temperature		η_c	Nominal COP
	Evaporator	Condenser		
City DC	–	–	–	12
Local water-source chiller	12	30	0.6	7.72

Appendix A.2 Economic parameters

The investment for heating and cooling sources are derived from technical reports about the DHC projects [52] in Nordic countries, as shown in Table A.4 and Table A.5. The annual operation and management (O&M) cost is expressed by its share in the total investment.

The flowrate is calculated by the hourly transmitted energy and the design operating temperature difference. Then, the pipe diameters and circulating water pumps are designed based on a maximum pressure loss gradient of 200 Pa/m. Investment for pipe $I_{pipe,i}$ is approximated from price lists from several manufactures [75], as expressed in Eq. (10). The lifespan of the DHC network is set as 35 years and the O&M share is 3 %.

Table A4

Investment of central and decentral heating and cooling sources (excluding the network).

	Investment (€/kW _{effect})	Lifetime (a)	Share of O&M
City DH	200	20	2 %
City DC	200	20	2 %
Community HP	550	20	3 %
DHW booster HP	500	20	2 %
DHW circulation HP	500	20	2 %
Local water-source chiller	350	20	3.5 %

Table A5

Investment for substation equipment. The pumps and control system are only used in the ULTDHC and 5GDHC systems.

	Investment (€/kW _{effect})	Lifetime (a)	Share of O&M
Space heating exchanger	50	15	1 %
Space cooling exchanger	50	15	1 %
DHW exchanger	40	15	1 %
Pumps and control system	100	15	0.5 %

$$I_{pipe,i} = 130 + 1870 \cdot D_i (\text{€}/m) \quad (10)$$

For water tank as TES unit, the investment per volume is highly dependent on its size, as reported in [43]. In terms of demand-side storage units, a fixed investment of 2000 €/m³ is used, which is relatively high due to costs for labor and installations. For community-level central storage units, the investment is set as 1200 €/m³, which represents the average cost for water tank that is around 10 to 50 m³ [45]. The lifetime of water tank is 15 years, and the annual O&M share is 1 %. For the centralized battery storage, the investment is set as 400 €/kWh and the lifetime is 10 years.

Reference

- Stocker T. Climate Change 2013: the physical science basis: Working Group I contribution to the Fifth assessment report of the Intergovernmental Panel on Climate Change. Cambridge University Press; 2014.
- European Commission. Eurostat - Statistics database 2021. <http://ec.europa.eu/eurostat>.
- European Commission. Energy and the Green Deal 2020. https://ec.europa.eu/info/strategy/priorities-2019-2024/european-green-deal/energy-and-green-deal_en (accessed April 7, 2022).
- Connolly D. Heat Roadmap Europe: Quantitative comparison between the electricity, heating, and cooling sectors for different European countries. Energy 2017;139:580–93. <https://doi.org/10.1016/j.energy.2017.07.037>.
- Connolly D, Lund H, Mathiesen BV, Werner S, Möller B, Persson U, et al. Heat roadmap Europe: Combining district heating with heat savings to decarbonise the EU energy system. Energy Policy 2014;65:475–89. <https://doi.org/10.1016/j.enpol.2013.10.035>.
- Lund H, Werner S, Wiltshire R, Svendsen S, Eric J, Hvelplund F, et al. 4th Generation District Heating (4GDH) Integrating smart thermal grids into future sustainable energy systems. Energy 2014;68:1–11. <https://doi.org/10.1016/j.energy.2014.02.089>.
- Lund H, Østergaard PA, Chang M, Werner S, Svendsen S, Sorknæs P, et al. The status of 4th generation district heating: Research and results. Energy 2018;164: 147–59. <https://doi.org/10.1016/j.energy.2018.08.206>.
- Yang X, Li H, Svendsen S. Evaluations of different domestic hot water preparing methods with ultra-low-temperature district heating. Energy 2016;109:248–59. <https://doi.org/10.1016/j.energy.2016.04.109>.
- Ommen T, Thorsen JE, Markussen WB, Elmegaard B. Performance of ultra low temperature district heating systems with utility plant and booster heat pumps. Energy 2017;137:544–55. <https://doi.org/10.1016/j.energy.2017.05.165>.
- Yang X, Svendsen S. Ultra-low temperature district heating system with central heat pump and local boosters for low-heat-density area: Analyses on a real case in Denmark. Energy 2018;159:243–51. <https://doi.org/10.1016/j.energy.2018.06.068>.
- Østergaard PA, Andersen AN. Economic feasibility of booster heat pumps in heat pump-based district heating systems. Energy 2018;155:921–9. <https://doi.org/10.1016/j.energy.2018.05.076>.
- Lund R, Østergaard DS, Yang X, Mathiesen BV. Comparison of low-temperature district heating concepts in a long-term energy system perspective. Int J Sustain Energy Plan Manag 2017;12:5–18. <https://doi.org/10.5278/ijsep.2017.12.2>.
- Meesenburg W, Ommen T, Thorsen JE, Elmegaard B. Economic feasibility of ultra-low temperature district heating systems in newly built areas supplied by renewable energy. Energy 2020;191:116496. <https://doi.org/10.1016/j.energy.2019.116496>.
- Buffa S, Cozzini M, D'Antoni M, Baratieri M, Fedrizzi R. 5th generation district heating and cooling systems: A review of existing cases in Europe. Renew Sustain Energy Rev 2019;104:504–22. <https://doi.org/10.1016/j.rser.2018.12.059>.
- Wirtz M, Kivilip L, Remmen P, Müller D. 5th Generation District Heating: A novel design approach based on mathematical optimization. Appl Energy 2020;260: 114158. <https://doi.org/10.1016/j.apenergy.2019.114158>.
- Wirtz M, Kivilip L, Remmen P, Müller D. Quantifying demand balancing in bidirectional low temperature networks. Energy Build 2020;224:110245. <https://doi.org/10.1016/j.enbuild.2020.110245>.
- Pellegrini M, Bianchini A. The innovative concept of cold district heating networks: A literature review. Energies 2018;11. <https://doi.org/10.3390/en11010236>.
- Bünning F, Wetter M, Fuchs M, Müller D. Bidirectional low temperature district energy systems with agent-based control: Performance comparison and operation optimization. Appl Energy 2018;209:502–15. <https://doi.org/10.1016/j.apenergy.2017.10.072>.
- Fränzén I, Nedar L, Andersson M. Environmental comparison of energy solutions for heating and cooling. Sustainability 2019;11. <https://doi.org/10.3390/su11247051>.
- Nik VM, Mata E, Sasic Kalagasidis A, Scartezzini JL. Effective and robust energy retrofitting measures for future climatic conditions - Reduced heating demand of Swedish households. Energy Build 2016;121:176–87. <https://doi.org/10.1016/j.enbuild.2016.03.044>.
- Kan X, Hedenus F, Reichenberg L. The cost of a future low-carbon electricity system without nuclear power – the case of Sweden. Energy 2020;195:117015. <https://doi.org/10.1016/j.energy.2020.117015>.
- Andrić I, Pina A, Ferrão P, Fournier J, Lacarrière B, Le Corre O. The impact of climate change on building heat demand in different climate types. Energy Build 2017;149:225–34. <https://doi.org/10.1016/j.enbuild.2017.05.047>.
- Nik VM, Sasic Kalagasidis A. Impact study of the climate change on the energy performance of the building stock in Stockholm considering four climate uncertainties. Build Environ 2013;60:291–304. <https://doi.org/10.1016/j.buildenv.2012.11.005>.
- Intergovernmental Panel on Climate Change, editor. Summary for Policymakers. Clim. Chang. 2013 – Phys. Sci. Basis Work. Gr. I Contrib. to Fifth Assess. Rep. Intergov. Panel Clim. Chang., Cambridge: Cambridge University Press; 2014, p. 1–30. <https://doi.org/10.1017/CBO9781107415324.004>.
- Larsen MAD, Petrović S, Radoszynski AM, McKenna R, Balyk O. Climate change impacts on trends and extremes in future heating and cooling demands over Europe. Energy Build 2020;226. <https://doi.org/10.1016/j.enbuild.2020.110397>.
- Andrić I, Fournier J, Lacarrière B, Le Corre O, Ferrão P. The impact of global warming and building renovation measures on district heating system techno-economic parameters. Energy 2018;150:926–37. <https://doi.org/10.1016/j.energy.2018.03.027>.
- Savvidou G, Nykvist B. Heat demand in the Swedish residential building stock - pathways on demand reduction potential based on socio-technical analysis. Energy Policy 2020;144. <https://doi.org/10.1016/j.enpol.2020.111679>.
- Hansen K, Connolly D, Lund H, Drysdale D, Thellufsen JZ. Heat Roadmap Europe: Identifying the balance between saving heat and supplying heat. Energy 2016;115: 1663–71. <https://doi.org/10.1016/j.energy.2016.06.033>.
- European Commission. Evaluation of the Energy Performance of Buildings Directive 2010/31/EU. 2015.
- European Commission. A Renovation Wave for Europe – Greening our buildings, creating jobs, improving lives 2020. https://energy.ec.europa.eu/topics/energy-efficiency/energy-efficient-buildings/renovation-wave_en.
- Nguyen T, Gustavsson L, Dodoo A, Tettey UYA. Implications of supplying district heat to a new urban residential area in Sweden. Energy 2020;194:116876. <https://doi.org/10.1016/j.energy.2019.116876>.
- Nielsen S, Thellufsen JZ, Sorknæs P, Djørup SR, Sperling K, Østergaard PA, et al. Smart energy Aalborg: Matching end-use heat saving measures and heat supply costs to achieve least-cost heat supply. Int J Sustain Energy Plan Manag 2020;25: 13–32. <https://doi.org/10.5278/ijsep.3398>.
- Åberg M, Widén J, Henning D. Sensitivity of district heating system operation to heat demand reductions and electricity price variations: A Swedish example. Energy 2012;41:525–40. <https://doi.org/10.1016/j.energy.2012.02.034>.
- Terrerros O, Spreitzhofer J, Basciotti D, Schmidt RR, Esterl T, Pober M, et al. Electricity market options for heat pumps in rural district heating networks in Austria. Energy 2020;196:116875. <https://doi.org/10.1016/j.energy.2019.116875>.
- Hast A, Rinne S, Syri S, Kiviluoma J. The role of heat storages in facilitating the adaptation of district heating systems to large amount of variable renewable electricity. Energy 2017;137:775–88. <https://doi.org/10.1016/j.energy.2017.05.113>.
- Kontu K, Rinne S, Junnila S. Introducing modern heat pumps to existing district heating systems – Global lessons from viable decarbonizing of district heating in Finland. Energy 2019;166:862–70. <https://doi.org/10.1016/j.energy.2018.10.077>.
- Romanchenko D, Odenberger M, Göransson L, Johnsson F. Impact of electricity price fluctuations on the operation of district heating systems: A case study of district heating in Göteborg, Sweden. Appl Energy 2017;204:16–30. <https://doi.org/10.1016/j.apenergy.2017.06.092>.

- [38] Wirtz M, Neumaier L, Remmen P, Müller D. Temperature control in 5th generation district heating and cooling networks: An MILP-based operation optimization. *Appl Energy* 2021;288:116608. <https://doi.org/10.1016/j.apenergy.2021.116608>.
- [39] Quirós G, Torres M, Chacartegui R. Analysis of the integration of photovoltaic excess into a 5th generation district heating and cooling system for network energy storage. *Energy* 2021;239:122202. <https://doi.org/10.1016/j.energy.2021.122202>.
- [40] Prasanna A, Dorer V, Vetterli N. Optimisation of a district energy system with a low temperature network. *Energy* 2017;137:632–48. <https://doi.org/10.1016/j.energy.2017.03.137>.
- [41] Wang D, Carmeliet J, Orehounig K. Design and Assessment of District Heating Systems with Solar Thermal Prosumers and Thermal Storage. *Energies* 2021;14:1184. <https://doi.org/10.3390/en14041184>.
- [42] Gadd H, Werner S. Thermal energy storage systems for district heating and cooling. Woodhead Publishing Limited; 2015. <https://doi.org/10.1533/9781782420965.4.467>.
- [43] Lund H, Østergaard PA, Connolly D, Mathiesen BV. Energy storage and smart energy systems. *Energy* 2017;137:556–65. <https://doi.org/10.1016/j.energy.2017.05.123>.
- [44] Zhang Y, Johansson P, Kalagasidis AS. Applicability of thermal energy storage in future low-temperature district heating systems – Case study using multi-scenario analysis. *Energy Convers Manag* 2021;244. <https://doi.org/10.1016/j.enconman.2021.114518>.
- [45] Lund H. Renewable heating strategies and their consequences for storage and grid infrastructures comparing a smart grid to a smart energy systems approach. *Energy* 2018;151:94–102. <https://doi.org/10.1016/j.energy.2018.03.010>.
- [46] Romanchenko D, Kensby J, Odenberger M, Johnsson F. Thermal energy storage in district heating: Centralised storage vs. storage in thermal inertia of buildings. *Energy Convers Manag* 2018;162:26–38. <https://doi.org/10.1016/j.enconman.2018.01.068>.
- [47] Swedish Energy Agency. Sveby Standard for the Energy use in Buildings 2014.
- [48] Zimmermann JP. End-use metering campaign in 400 households in Sweden Assessment of the Potential Electricity Savings. *Contract* 2009;17:05-2743. [https://doi.org/Contract 17-05-2743](https://doi.org/Contract%2017-05-2743).
- [49] Jordan U, Vajen K. Realistic domestic hot-water profiles in different time scales. *Rep Sol Heat Cool Progr Int Energy Agency (IEA-SHC)Task* 2001;26:1–18.
- [50] Braas H, Jordan U, Best I, Orozaliev J, Vajen K. District heating load profiles for domestic hot water preparation with realistic simultaneity using DHWcalc and TRNSYS. *Energy* 2020;201:117552. <https://doi.org/10.1016/j.energy.2020.117552>.
- [51] Sweden interest rates 2019. <http://sweden.deposits.org> (accessed October 13, 2020).
- [52] Danish Energy Agency. Technology data Generation of Electricity and District heating 2016:382.
- [53] Nord N, Ding Y, Ivanko D, Walnum HT. DHW tank sizing considering dynamic energy prices. *E3S Web Conf* 2021;246:1–7. <https://doi.org/10.1051/e3sconf/202124607005>.
- [54] Li H, Hou J, Tian Z, Hong T, Nord N, Rohde D. Optimize heat prosumers' economic performance under current heating price models by using water tank thermal energy storage. *Energy* 2022;239:122103. <https://doi.org/10.1016/j.energy.2021.122103>.
- [55] Floss A, Hofmann S. Optimized integration of storage tanks in heat pump systems and adapted control strategies. *Energy Build* 2015;100:10–5. <https://doi.org/10.1016/j.enbuild.2015.01.009>.
- [56] Fertahi S ed D, Jamil A, Benbassou A. Review on Solar Thermal Stratified Storage Tanks (STSST): Insight on stratification studies and efficiency indicators. *Sol Energy* 2018;176:126–45. <https://doi.org/10.1016/j.solener.2018.10.028>.
- [57] Cruickshank CA, Harrison SJ. Heat loss characteristics for a typical solar domestic hot water storage. *Energy Build* 2010;42:1703–10. <https://doi.org/10.1016/j.enbuild.2010.04.013>.
- [58] Rehman H ur, Reda F, Paiho S, Hasan A. Towards positive energy communities at high latitudes. *Energy Convers Manag* 2019;196:175–95. <https://doi.org/10.1016/j.enconman.2019.06.005>.
- [59] Leff HS, Teeters WD. EER, COP, and the second law efficiency for air conditioners. *Am J Phys* 1978;46:19–22. <https://doi.org/10.1119/1.11174>.
- [60] Jangsten M, Filipsson P, Lindholm T, Dalenbäck JO. High temperature district cooling: challenges and possibilities based on an existing district cooling system and its connected buildings. *Energy* 2020;199. <https://doi.org/10.1016/j.energy.2020.117407>.
- [61] Maivel M, Kurnitski J. Heating system return temperature effect on heat pump performance. *Energy Build* 2015;94:71–9. <https://doi.org/10.1016/j.enbuild.2015.02.048>.
- [62] Vivian J, Emmi G, Zarrella A, Jobard X, Pietruschka D, De Carli M. Evaluating the cost of heat for end users in ultra low temperature district heating networks with booster heat pumps. *Energy* 2018;153:788–800. <https://doi.org/10.1016/j.energy.2018.04.081>.
- [63] Schmidt D, Kallert A, Blesl M, Svendsen S, Li H, Nord N, et al. Low temperature district heating for future energy systems. *Energy Procedia* 2017;116:26–38. <https://doi.org/10.1016/j.egypro.2017.05.052>.
- [64] Thorsen JE, Ommen T. Field experience with ULTDH substation for multifamily building. *Energy Procedia* 2018;149:197–205. <https://doi.org/10.1016/j.egypro.2018.08.184>.
- [65] Yang X, Li H, Svendsen S. Energy, economy and exergy evaluations of the solutions for supplying domestic hot water from low-temperature district heating in Denmark. *Energy Convers Manag* 2016;122:142–52. <https://doi.org/10.1016/j.enconman.2016.05.057>.
- [66] Lund H, Østergaard PA, Nielsen TB, Werner S, Thorsen JE, Gudmundsson O, et al. Perspectives on fourth and fifth generation district heating. *Energy* 2021;227:120520. <https://doi.org/10.1016/j.energy.2021.120520>.
- [67] Mata É, Sasic Kalagasidis A, Johnsson F. Energy usage and technical potential for energy saving measures in the Swedish residential building stock. *Energy Policy* 2013;55:404–14. <https://doi.org/10.1016/j.enpol.2012.12.023>.
- [68] Nik Moussavi V. *Hygrothermal simulations of buildings concerning uncertainties of the future climate*, PhD. Gothenburg, Sweden: Chalmers University of Technology; 2012.
- [69] IPCC. The Intergovernmental Panel on Climate Change 2022. <https://www.ipcc.ch/> (accessed June 1, 2022).
- [70] Swedish Energy Agency (Energimyndigheten). *Energy in Sweden 2022*. <http://www.energimyndigheten.se/en/facts-and-figures/statistics/> (accessed February 21, 2022).
- [71] Göransson L, Goop J, Unger T, Odenberger M, Johnsson F. Linkages between demand-side management and congestion in the European electricity transmission system. *Energy* 2014;69:860–72. <https://doi.org/10.1016/j.energy.2014.03.083>.
- [72] Gadd H, Werner S. Daily heat load variations in Swedish district heating systems. *Appl Energy* 2013;106:47–55. <https://doi.org/10.1016/j.apenergy.2013.01.030>.
- [73] Tan P, Lindberg P, Eichler K, Löveryd P, Johansson P, Kalagasidis AS. Thermal energy storage using phase change materials: Techno-economic evaluation of a cold storage installation in an office building. *Appl Energy* 2020;276:115433. <https://doi.org/10.1016/j.apenergy.2020.115433>.
- [74] Göteborg Energi. *District heating prices in Gothenburg 2021*. <https://www.goteborgenergi.se/foretag/fjarrvarme/fjarrvarmepriser> (accessed December 23, 2021).
- [75] Best I, Orozaliev J, Vajen K. Economic comparison of low-temperature and ultra-low-temperature district heating for new building developments with low heat demand densities in Germany. *Int J Sustain Energy Plan Manag* 2018;16:45–60. <https://doi.org/10.5278/ijsepm.2018.16.4>.