



CHALMERS
UNIVERSITY OF TECHNOLOGY

Evaluation of a Back-up Range Extender and Other Heavy-Duty BEV-Supporting Systems

Downloaded from: <https://research.chalmers.se>, 2026-04-04 04:25 UTC

Citation for the original published paper (version of record):

Zander, L., Svens, P., Svärd, H. et al (2022). Evaluation of a Back-up Range Extender and Other Heavy-Duty BEV-Supporting Systems. *World Electric Vehicle Journal*, 13(6).
<http://dx.doi.org/10.3390/wevj13060102>

N.B. When citing this work, cite the original published paper.



Article

Evaluation of a Back-up Range Extender and Other Heavy-Duty BEV-Supporting Systems

Lennarth Zander *, Pontus Svens, Henrik Svärd and Petter Dahlander

Mechanics and Maritime Sciences, Chalmers University of Technology, 412 96 Gothenburg, Sweden; pontus.svens@scania.com (P.S.); henrik.svard@scania.com (H.S.); dallas@chalmers.se (P.D.)

* Correspondence: lennarth.zander@scania.com

Abstract: Electric powertrains in terms of battery electric vehicles (BEV) are considered to be very interesting for heavy truck transportations. The challenge is the need for very large onboard energy and batteries. Long-term fuel cells (FCs) are considered an interesting support system for heavy-duty BEV, but in the short term, a range extender (REX) is also interesting. A heavy-duty BEV with 970 kWh batteries installed can handle 27% of all possible missions for the Scania fleet considering daily recharging. The back-up range extender (BUREX) can expand this figure to 55% utilized 20 days per year. If a customer has a few very energy-demanding use cases each year and does not want to pay for all the batteries needed, the BUREX may be an especially good option. The BUREX reduces life-cycle CO₂ emissions, irrespective of the generation mix of the grid supplying the electricity used in vehicle manufacturing and battery charging. The BUREX reuse of the existing electric components of the BEV powertrain enables the installation of a 10% larger battery pack while being 80% less costly. The BUREX also adds redundancy to the BEV concept while recharging infrastructure improves, especially in rural places. These results indicate that the BUREX concept is a powerful short-term solution that could enable greater use of HD FC and BEV trucks while charging infrastructure and FC technologies gradually become more mature.

Keywords: two-stroke; rex; range extender; fuel cell; FC



Citation: Zander, L.; Svens, P.; Svärd, H.; Dahlander, P. Evaluation of a Back-up Range Extender and Other Heavy-Duty BEV-Supporting Systems. *World Electr. Veh. J.* **2022**, *13*, 102. <https://doi.org/10.3390/wevj13060102>

Academic Editor: Michael Fowler

Received: 9 May 2022

Accepted: 7 June 2022

Published: 10 June 2022

Publisher's Note: MDPI stays neutral with regard to jurisdictional claims in published maps and institutional affiliations.



Copyright: © 2022 by the authors. Licensee MDPI, Basel, Switzerland. This article is an open access article distributed under the terms and conditions of the Creative Commons Attribution (CC BY) license (<https://creativecommons.org/licenses/by/4.0/>).

1. Introduction

1.1. General Push for BEV-Supporting Systems

The decarbonization of the automotive industry is needed to mitigate global climate change, and several automotive companies have accepted the challenge it presents by joining the Science Based Targets initiative [1]. Promising potential zero-tailpipe-emission technologies for vehicles include battery electric and fuel cell (FC) systems. Although these technologies are less mature than conventional drivetrains, global sales of electric vehicles are steadily increasing [2]. A major limitation of battery electric vehicles (BEVs) for heavy-duty (HD) applications is that they require large energy storage systems (i.e., batteries), especially for applications involving highly energy-consuming long-distance driving over hilly terrain. If the set of driving cycles for a given HD BEV application includes only a few such extremely energy-intensive driving events, it becomes necessary to equip the vehicle with a much larger and more costly energy storage system than it usually need to ensure that these events can be accommodated. It might be possible to use a smaller battery if two recharging events per day could be accepted, but it is usually preferable to only recharge vehicles overnight.

1.2. Batteries Are Expensive and Less Energy-Dense Than Fuel, and Depend on Recharging Infrastructure

Despite important technological advances, batteries are rather expensive and are currently around 60 times heavier than oil-based fuels with the same energy content [3].

In addition, large amounts of energy are needed to produce batteries [4]. Consequently, the CO₂ footprint of a BEV depends strongly on the carbon intensity of the electricity consumed during its usage and production, which in turn depends on the generation mix of the local electric grid. Another practical factor to consider is the availability of recharging stations along the vehicle's expected routes and their power output, which may be especially important if the route passes through rural areas where the number of available and functioning charging stations may be uncertain. A final issue is that a lack of recharging opportunities could be harmful or even fatal to a vehicle's driver if it is caught without power during an extreme weather event. These issues can be avoided by equipping HD BEVs with an onboard recharging system such as an REX or FC, which makes it possible to use a comparatively small and inexpensive battery while still being able to complete occasional extreme driving cycles. However, in a situation where few recharging stations are available during a more normal driving cycle, neither an REX nor an FC will greatly increase a BEV's robustness.

1.3. FC Is the Long-Term Solution and REX Can Cover the Transfer

The most common FC type used in automotive applications is the proton-exchange membrane fuel cell (PEMFC), which produces electricity directly through an electrochemical process using hydrogen as the fuel and emitting only water. The PEMFC is seen as the long-term solution to onboard BEV recharging because it produces no toxic emissions, has a small carbon footprint, and can be highly efficient compared to an internal combustion engine (ICE) [5]. However, the infrastructure and technology required to support the widespread use of FCs is currently lacking. Moreover, current PEMFCs for HD vehicles have limited power density, and hydrogen is challenging to store on a vehicle because of its low density [6]. An REX is an ICE that is linked to a generator and placed onboard the vehicle. An REX is more flexible than a PEMFC in terms of fuels because both compression ignition (CI) and spark ignition (SI) engines can be used. The power density of an REX also exceeds that of an FC, but its reliance on carbon-based fuels means it will emit pollutants and greenhouse gases. Light-duty (LD) BEVs have been available for some time now and several publications have described the use of REX in LD-BEVs. However, the onboard energy storage requirements of LD BEVs are much smaller than those of HD BEVs. Lotus, Mahle, AVL, and other firms [5,7–13] have conducted several interesting studies on LD REX applications, and it appears that concepts using 2-or-3-cylinder four-stroke SI engines having power outputs of around 20 kW are preferred for such systems.

1.4. Can the BUREX Challenge the More Traditional REX?

All published concepts have been in-use REX (IUREX) systems with a separate genset unit in which the ICE is linked to an independent electric machine serving as a generator. The IUREX for an LD BEV can be rather small, but that for an HD BEV would need to be much larger because an REX for rapid battery recharging in an HD BEV would need a power output of 150 kW to achieve thermal balance and an acceptable recharging speed. A suitable ICE for this purpose would be a 2.0 L SI or CI engine from a light-duty vehicle operating in conjunction with a large low-speed generator (~4000 rpm). However, the installation volume on an HD vehicle is limited, and such a solution would occupy space that could otherwise be used for a larger battery. An alternative would be a backup range extender (BUREX) system where the ICE is installed directly on the existing electric machine of the BEV powertrain, and this electric machine and its power electronics serve as the generator. The available installation volume around the electric transmission in an HD BEV is limited; therefore, only a single-cylinder two-stroke engine with a small displacement (e.g., 425 cc) could be considered. Figure 1 compares the proposed layout of a BUREX system in an HD BEV to that of a pure BEV and two other range-extending BEV support systems.

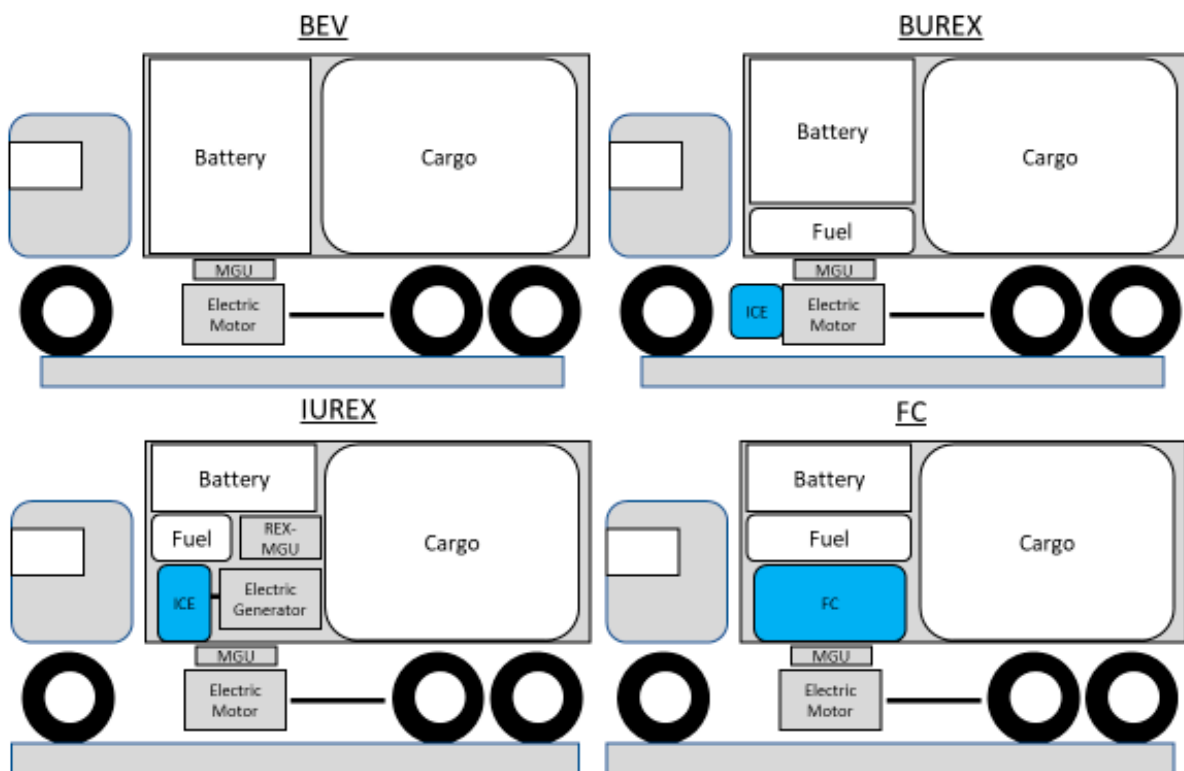

Figure 1. A pure HD BEV and BEVs with different range-extending support systems.

A two-stroke engine can be made smaller than a single-cylinder four-stroke engine and the power density can be higher. We have previously shown that a power density of 400 kW/L swept volume can be achieved with a 125 cc two-stroke engine while maintaining acceptable durability for REX applications [14]. It was also concluded that a specially engineered air charging system is needed to achieve this power density and that an afterburner-supported turbocharger system could meet this requirement. Other studies have also investigated the use of two-stroke engines for similar purposes [10–12,15–18] but have not focused on single-cylinder applications. Because it was shown that the desired power density could be obtained, simulations were performed to investigate the performance of an upscaled 425 cc engine delivering the 150 kW power output desired for HD REX applications [18]. The upscaled engine was predicted to deliver the target peak power, and it was concluded that one cylinder from an existing 850 cc two-cylinder snowmobile engine could serve as a practical starting point for the development of such an engine. Figure 2 presents the basic principles of the BUREX two-stroke engine and its charging system.

The purpose of this article is to compare the BUREX concept to other REX concepts and FC systems in order to answer the following questions:

How does the BUREX concept compare to the IUREX and FC concepts in terms of installation factors?

How does the BUREX concept compare to the IUREX and FC concepts in terms of cost?

The CO₂ footprint of an REX system does not depend solely on combustion during operation (as is the case for an ICE); it also depends on the carbon intensity of the electric grid supplying the power used in the production of powertrain components and when recharging during operation. How do these factors compare in actual driving cycles and for different generation mixes?

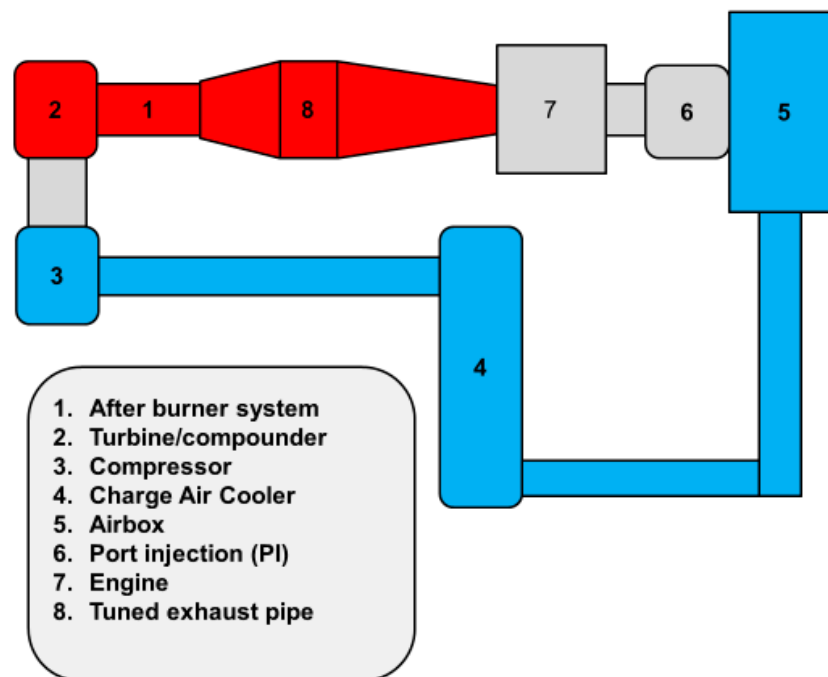

Figure 2. The BUREX engine is a single-cylinder two stroke engine with an afterburner-assisted turbocharged system that increases power density and reduces exhaust emissions. The target power of 150 kW can be achieved using a cylinder with a swept volume of 425 cc.

2. Materials and Methods

2.1. ICE Development

Although the BUREX concept has been described in detail elsewhere [14], it is a new concept, and thus a short summary of the earlier publication is provided here to help readers follow the forthcoming discussion. As stated in the Introduction section, a single-cylinder two-stroke SI engine is the preferred ICE type for an REX based on the system's installation and performance requirements. One-dimensional engine simulations and engine dynamometer (dyno) experiments were performed to evaluate the gas exchange and charging system of a single-cylinder crank-case-scavenged two-stroke SI engine. The simulations revealed that some kind of charging system is needed to achieve the required specific performance levels. Since a two-stroke engine is neither self-aspirated nor self-exhausting, it uses the crank case as a scavenge pump. This scavenging system makes such engines highly sensitive to the pressure balance between the air and exhaust sides; the exhaust pressure cannot be as low as in a mechanically driven supercharger system, but it also cannot be as high as is common in turbocharger systems. The exhaust temperature is also limited because of hardware component constraints in the engine and significant thermal losses in the very specific exhaust systems needed in engines of the intended type. On the positive side, the exhaust gases of the proposed engine are rich in hydrocarbons (HC) and air, which can be converted into heat in an afterburner system using an oxidation catalyst and can thus improve both the performance of the turbocharging system and the engine's emissions profile. The system is shown in Figure 2; its design was tested experimentally using a small 125 cc engine and in 1D engine simulations. The hardware used in the system (in particular, the turbocharger) was chosen on the basis of the 1D model shown in Figure 3.

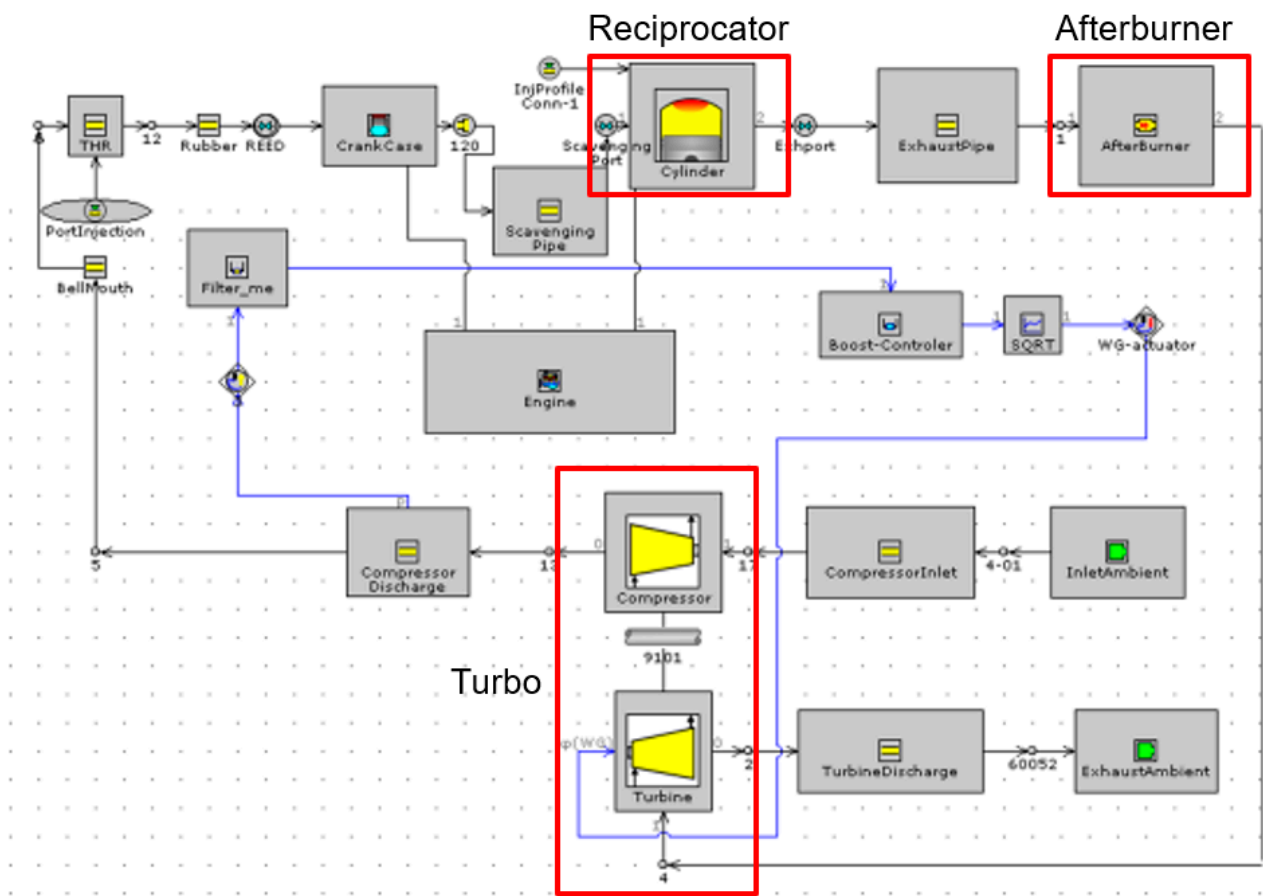

Figure 3. The 1D engine model generated using the GT-Suite software package including turbocharger and afterburner objects.

Engine dyno experiments were performed in an engine dyno, and the test object was a motorbike-type engine whose power output is shown in Figure 4. A two-stroke engine can operate at up to 12,000 rpm, which made it convenient to use an engine with a step-down gear so that the dyno could be operated at lower speeds in the engine experiments. A step-down gear is a standard component in a motorbike engine and similar commercial two-stroke engines.

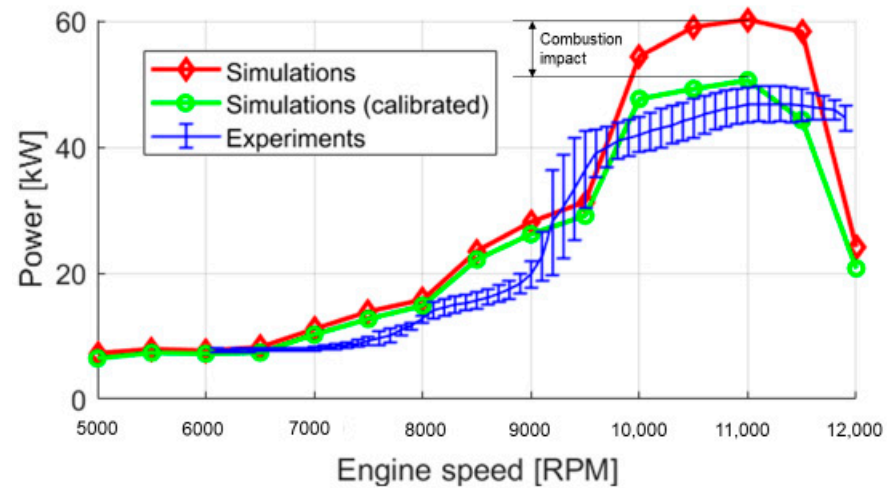

Figure 4. Uncalibrated and calibrated simulation model results and experimental validation.

Most of the engine experiments were conducted with engine-speed-resolved output, but crank-resolved data were also recorded because the heat release in the cylinder was not actually modelled in the 1D engine simulation software and had to be calibrated against crank-resolved pressure traces from engine experiments to improve the quality of the simulations. Because the exhaust pipe in a two-stroke engine behaves as a charging system operating with finite pressure waves, it was important to calibrate the 1D engine simulation model using pressure traces recorded close to the cylinder to obtain meaningful simulation results. The performance at high speeds for this type of two-stroke engine is highly dependent on the gas dynamics in the exhaust pipe. Small discrepancies in exhaust temperature between the 1D model and the experimental engine are leveraged in the power curve. On top of this, the charging system rebalances the pressures on the air and exhaust side, which impacts exhaust temperature. As an example, the simulation model generates less power at 11,500 rpm compared to the experimental engine. The reason is a drop in torque in the model because the average exhaust temperature in the tuned exhaust pipe drops more quickly in the model than in the experimental engine. This occurs because some fuel and air oxidates in the transport through the pipe, which is not covered in the model.

The research on the 125 cc engine showed that a specific power of 400 kW/L could be achieved. Subsequent efforts therefore focused on scaling the engine up from 125 cc to 425 cc to reach the target power output of 150 kW needed for an HD REX [18]. The upscaling process was achieved by taking a single cylinder from a two-cylinder 850 cc two-stroke snowmobile engine as a reference for the desired turbocharged single-cylinder engine. Figure 5 shows that the engine's maximum power output comfortably exceeded the target value, providing a large engineering margin.

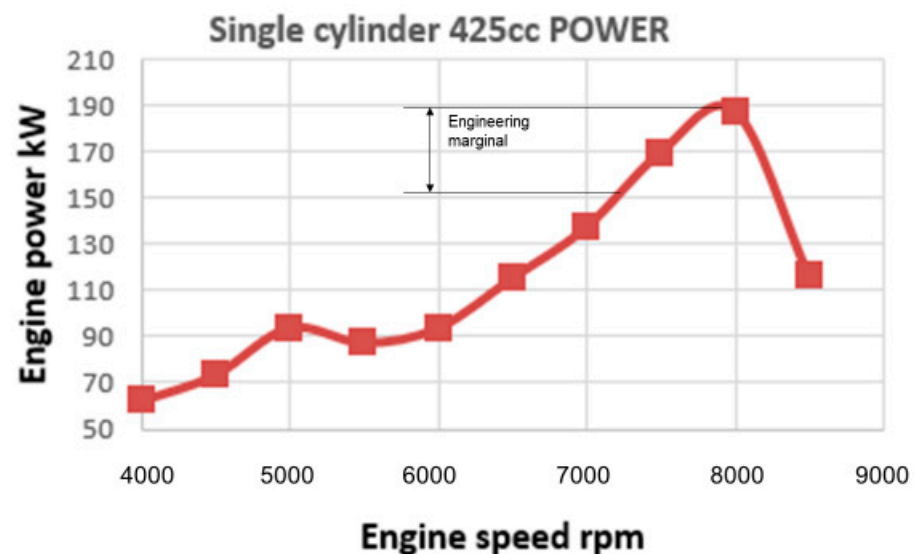

Figure 5. The upscaled 425 cc engine comfortably exceeded the desired power output of 150 kW, giving a large engineering margin.

2.2. Installation of the Range Extender

It was assumed that a total volume of 3 m³ was available to accommodate the BEV powertrain including the range extender or fuel cell system. Assuming that the electric powertrain components have a volume of 0.125 m³, the remaining volume of 2.875 m³ would be available for battery installation. Based on the expected volume-to-energy ratios of batteries that will be available in the year 2025 [19,20], this would give a pure BEV truck a possible total installed energy storage capacity of 970 kWh, which allows a reasonable range of missions to be performed without imposing excessive costs. The REX and FC systems were all dimensioned to provide a total energy storage capacity of 1580 kWh including the battery. The IUREX system requires a larger installation volume than the BUREX system because it includes a conventional ICE and a separate electric motor/generator and power

electronics capable of supporting the 150 kW power output needed to recharge the battery at an acceptable speed. The ICE in this case would be a four-cylinder four-stroke SI or CI engine. The BUREX ICE is smaller and can be mounted directly on the existing powertrain without requiring an additional electric motor (EM) or power electronics (MGU). Therefore, the BUREX design can carry a greater volume of batteries while achieving a comparable output power to the IUREX. However, the ICE of the BUREX is less efficient than that of the IUREX; a larger fuel tank is thus required. The FC is more efficient than the REX systems but requires a bulky hydrogen storage system. Electric powertrains are easier to optimize for city applications or distribution because the daily energy consumption in such applications is lower than in long haulage. Distribution driving and bus driving cycles also involve a lot of braking, which conveniently allows for energy regeneration through the electric transmission. Long haulage therefore presents the greatest challenge in terms of energy storage, especially if the haulage route includes hilly terrain and only overnight charging is accepted. Another challenge arises if the customer's driving cycles are not homogeneously distributed over time; consider a customer whose driving cycles are usually shorter than 400 km but are occasionally 800 km long. To meet all the needs of such a customer, a BEV would require a large and expensive battery pack whose capacity would mostly go unused.

2.3. REX Utilization

An often-overlooked issue when evaluating powertrains and energy storage solutions is the day-to-day variance in energy usage. In a pure BEV, this variance means that the battery must be dimensioned based on the worst case, i.e., the day with the highest energy usage, resulting in a battery that is oversized under all other operating conditions. This oversizing is expensive and increases both CO₂ emissions and raw material consumption during battery production, potentially reducing the rate at which the world's vehicle fleet can be electrified.

Because the space for battery installation is limited, this variance means that a significant number of vehicles will be more or less impossible to electrify; it will not be possible to install a battery large enough to provide the amount of energy consumed on the most energy-intensive days, even if those days occur only a few times per year. This may hinder the transition to electric propulsion. Note that such highly energy-consuming vehicles generate a large proportion of CO₂ emissions, and so their electrification is urgently needed to control climate change.

A vehicle with a range extender, on the other hand, does not necessarily need the installed battery capacity to have enough capacity to cover every single use case. Instead, the batteries can be dimensioned for maximum utilization while the range extender covers the occasional days where energy consumption is much higher than usual. This also means that a range extender could expand the population of vehicles that can be electrified to encompass a greater number of the most energy-intensive use cases that produce high CO₂ emissions.

To study the effect of a range extender on the required battery capacity and the proportion of the current vehicle fleet that can be electrified, data from the existing fleet of Scania trucks was used. The daily usage of energy of every vehicle in the fleet was estimated for every day during one year of operation, and the implications for fleet electrification were evaluated.

The daily propulsion energy need of each vehicle was calculated from the daily fuel consumption, which is available through the fleet management system, using the following expression:

$$E_i = V_{fuel,i} * E_{fuel} * \eta_{ICE}$$

Here, E_i is the propulsion energy on day i , $V_{fuel,i}$ is the volume of fuel consumed by the vehicle during day i , E_{fuel} is the energy density of the used fuel, and η_{ICE} is the assumed mean efficiency of the vehicle engine.

The proportion of the current fleet that can be electrified (α) for a given installed battery capacity E_{batt} can be estimated using the following equation if we state that a range extender can be used on n days:

$$\alpha = \frac{N_{below}(E_{batt}, n)}{N}$$

Here, $N_{below}(E_{batt}, n)$ is the number of vehicles in the fleet for which the daily energy usage during a year exceeds E_{batt} at most n times, and N is the total number of vehicles in the fleet.

2.4. The CO₂ Footprint

The materials used in the production of heavy-duty vehicles, notably steel, contribute significantly to their life-cycle CO₂ emissions. Consequently, initiatives such as HYBRIT [21] have been established to reduce these CO₂ emissions. The CO₂ footprints of the different range-extension concepts evaluated in this work were estimated by accounting for several different contributions.

First, the production of both batteries and fuel generates a CO₂ footprint. The CO₂ contribution from battery production is estimated to be 85 kg CO₂/kWh if produced in countries with low-carbon-intensity electricity [22].

The same is true for the production of fuel cells and hydrogen storage, for which the CO₂ footprints are estimated to be 30 kg CO₂/kW and 30 kg CO₂/kWh, respectively [23]. Once manufactured, these systems generate electricity on the vehicle using hydrogen that is independent of the local electricity generation mix.

Diesel production is estimated to have a carbon footprint of 60 g CO₂/kWh, and its combustion generates emissions of 265 gCO₂/kWh, giving a total footprint of 325 g CO₂/kWh [24,25].

Hydrogen can be produced in several ways. The CO₂ footprint of hydrogen production by the steam reforming of methane (the SMR process) is 210 g CO₂/kWh. This is the most widely used hydrogen production technology at present, and it has been analysed in detail [24].

In our calculations, we assume an average fleet distance of 200,000 km/year, and that 5 tons of steel are needed to build a truck, generating 9 tons of CO₂ per vehicle [21]. A BEV truck is assumed to consume 1.3 kWh/km. The IUREX ICE is assumed to have an efficiency of 40% and the BUREX ICE an efficiency of 20%. Battery recharging generates a CO₂ footprint that depends on the local electricity generation mix. In our comparisons, we use electricity obtained from three different countries: China (900 g CO₂ /kWh), France (105 g CO₂/kWh), and Sweden (47 g CO₂/kWh). These values influence the operational CO₂ emissions in the BEV case [26].

2.5. Cost and Redundancy

FC-based solutions are currently rather costly because FC technology is at an early stage of development. Hydrogen can be distributed and produced in different ways. The cost estimates presented here are based on a 150 kW FC unit for comparative purposes. Such a unit is expected to cost EUR 40,000 in 2025 [27]. The additional cost of a 1296 kWh hydrogen storage system is estimated to be EUR 19,000 in 2025 [28]. The IUREX design including the exhaust after treatment (EATS) and additional electric components is estimated to cost EUR 8000. The BUREX is not a fully developed solution but, since a single-cylinder two-stroke engine has fewer parts than the ICE of the IUREX system and the rest of the design uses existing electric components, this system is estimated to cost EUR 1500. The BUREX design could thus be implemented at around 20% of the cost of the IUREX design.

The redundancy aspect is based on the potential absence of available external charging once the truck's stored energy has been consumed. There are many reasons why an external charging station may be unavailable. First, the electric network may be down or malfunctioning because of adverse weather or seismological events. Additionally, the

distances between charging stations in rural areas may be large, exacerbating the problem. If this situation is combined with extreme weather conditions such as extreme heat or cold, the situation may become very challenging for the vehicle's occupants. It is important to note that recharging may require preheating of the batteries, which will prolong the recharging process. Redundancy can be achieved by having an onboard back-up system available to support thermal management of the electrical system and the cabin, providing an opportunity to recharge the batteries and travel onwards to the next charging station.

3. Results

3.1. Installation Aspect

A total installation volume of 3 m³ was permitted for each of the BEV concepts. The volume allocated to different powertrain and energy storage components in each concept is shown in Table 1. The ICEs of the two REX systems had different efficiencies and thus required differently sized fuel tanks. Both REX candidates reduced the battery volume by around 20% while increasing the range by approximately 50% when compared to the pure BEV concept because of the greater energy density of fuel when compared to batteries. The BEV concept had 970 kWh electrical energy stored in the batteries. Because of the volume occupied by the range extender components, the electric battery energy was slightly reduced for the range extender candidates. However, stored fuel will more than compensate for this, and both REX candidates will have the same total stored energy as the FC to make a fair comparison. The BUREX is a very small engine and is stored directly on the existing electric powertrain, which saves room for batteries. The efficiencies were taken into account, and so the stated total energy is electric energy (see Table 1).

Table 1. Volume occupied by different components of the BEV, BUREX, IUREX, and FC systems.

Item		BEV	BUREX	IUREX	FCEV
Total installation volume	(m ³)	3	3	3	3
Volume occupied by electric powertrain	(m ³)	0.1	0.1	0.3	0.1
Volume occupied by ICE or FC	(m ³)	0	0	0.2	0.4
Volume occupied by fuel storage	(m ³)	0	0.13	0.06	1.6
Volume occupied by batteries	(m ³)	2.9	2.5	2.4	0.8
Estimated efficiencies	(%)	90	20	40	60
Battery energy stored onboard	(kWh)	970.3	935	810	281
Fuel energy stored onboard	(kWh)	0	728	784	1296
Total energy stored onboard	(kWh)	970.3	1563	1594	1577
Emitted CO₂	(kWh)	283	916	482	338

3.2. REX Utilization

The relationship between expected driving cycles and onboard energy storage is shown in Figure 6. The results plotted in this figure are based on the analysis of Scania's truck fleet and show that the vehicles with the highest energy demand would need 3000 kWh of onboard energy storage to complete 100% of their current missions. This is feasible with current ICE powertrains and large fuel tanks but would be very costly for a pure BEV truck, while also requiring an extremely heavy and volume-intensive battery system. Current data suggest that a total battery capacity of around 970 kWh is more realistic, which is consistent with the installation volume assumed in this work. This amount of energy storage would be sufficient to meet the needs of 27% of all existing vehicles, as shown in Figure 6b: enter the diagram at 970 kWh (available battery energy in the BEV) in Figure 6b and go up to the blue curve for 0 days per year usage of the BUREX and proceed from here horizontally and

read 27% share of the fleet. Moreover, try to go from 935 kWh (available battery energy in the BUREX) in Figure 6b and proceed to the magenta curve for 20 days per year usage if the BUREX is used and from here horizontally and read 55% share of the fleet. A 150 kW REX could be significant in this context, depending on how frequently it is permitted to be engaged. Allowing the range extender to be used for 20 days each year would expand the driving cycle coverage to almost 60% of all vehicles despite slightly reducing the battery capacity of the REX vehicle relative to that of a pure BEV. The inclusion of an REX or FC system also solves the problems posed by occasional driving cycles in rural areas where recharging stations are scarce.

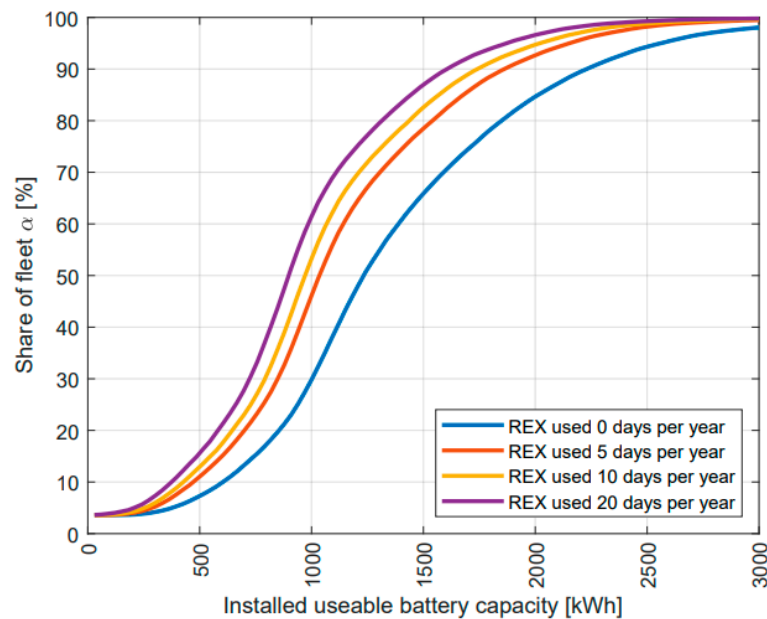

(a)

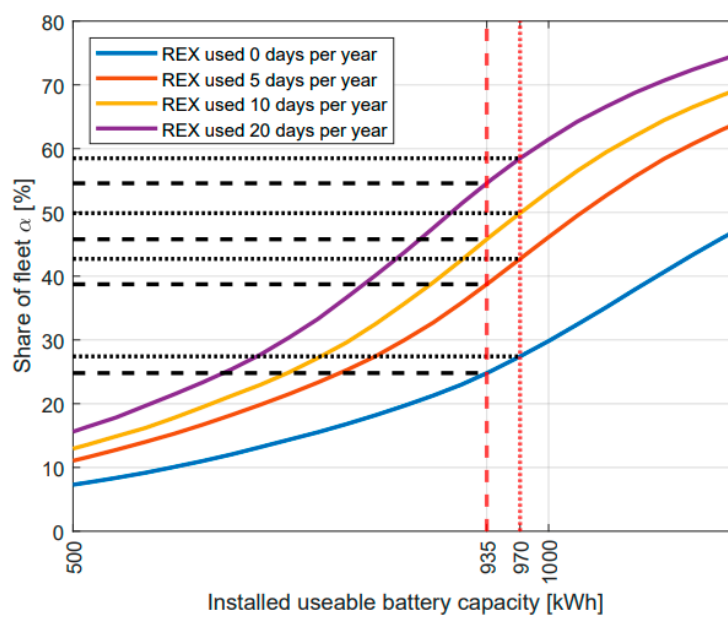

(b)

Figure 6. (a) Onboard energy storage needed to cover different fractions of the vehicles of the Scania fleet using BEV trucks showing how increasing REX utilization can either expand the coverage of vehicles that can be electrified or reduce the battery size while maintaining constant vehicle coverage. (b) Expansion of the results plotted in (a) focusing on the region around 1000 kWh.

3.3. The CO₂ Footprint

The CO₂ emissions of the pure BEV truck and trucks using REX and FC systems are compared for different electric grid generation mixes in Figure 7. Surprisingly, the range extender vehicles were found to emit less CO₂ than the pure BEV truck. Although counter-intuitive at first glance, this is explained by the fact that the REX vehicles carry fewer batteries; less CO₂ is therefore emitted during their production. Since the range extenders are only used a few times per year, the decrease in CO₂ emissions during production offsets the increased emissions during operation. The difference in CO₂ emissions between the BUREX and IUREX concepts when compared to the pure BEV concept depends heavily on the generation mix of the electric grid used to recharge the batteries. The BUREX can be fuelled with CO₂-neutral ethanol, which makes the situation even better. This could especially be the case in markets such as Brazil and USA, where the bioethanol production is based on local feedstock such as sugar cane and corn, respectively [29]. The IUREX performed a little better because of the improved efficiency of its ICE compared to the BUREX ICE. Both REX concepts increase the vehicle's CO₂ footprint when used. However, the BUREX is only to be used under emergency conditions at a standstill, when the CO₂ footprint may be a secondary concern; it is designed to provide robustness under extreme and rare conditions where external charging is unavailable. In addition to providing onboard charging, it is used for the thermal management of electric powertrain components, which is important for charging under cold conditions.

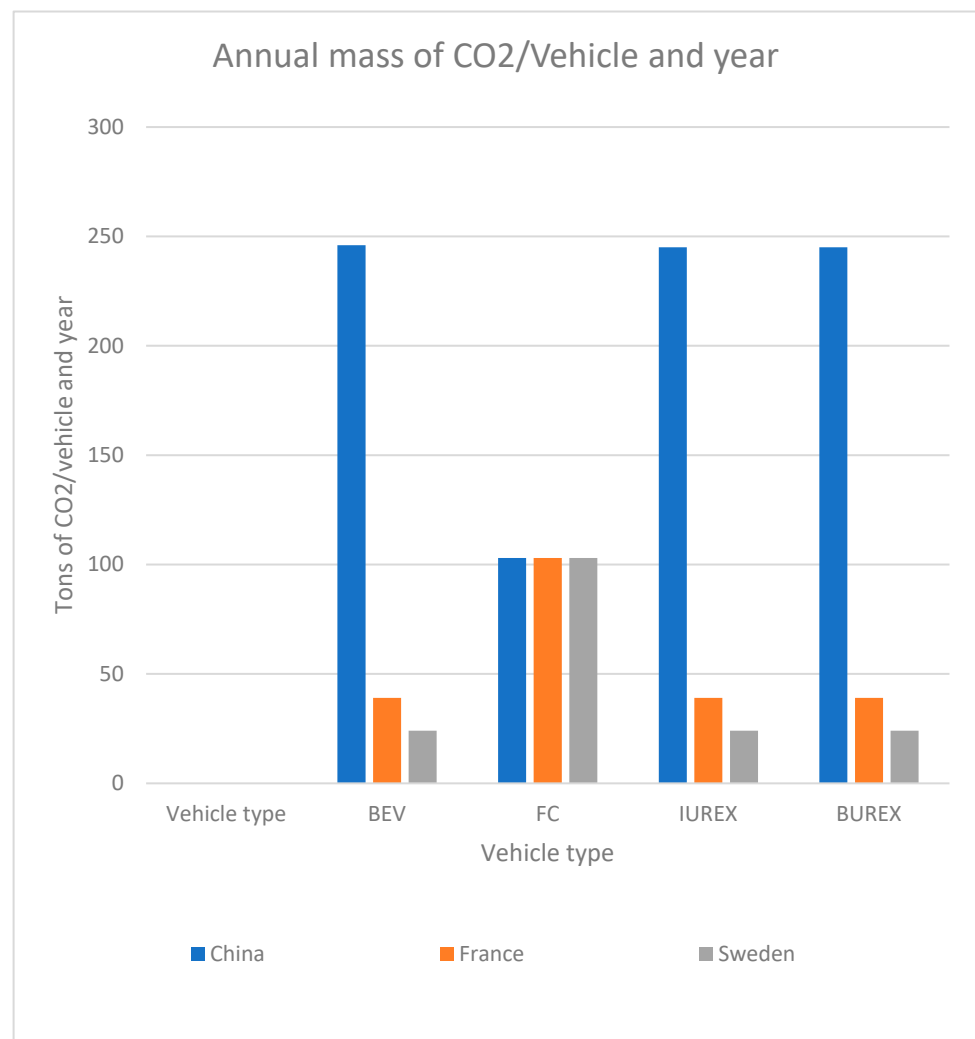

Figure 7. The local electricity generation mix strongly affects the potential of REX and FC systems to reduce CO₂ emissions.

4. Discussion

REX and FC are interesting supporting systems for HD BEV applications involving occasional long-distance driving with heavy loads on hilly terrain. The energy storage capacity needed for such driving cycles would necessitate the inclusion of an unfeasibly large battery in a pure BEV, but it can be provided relatively easily by using an REX or FC system to complement a battery that is used in less energy-intensive driving scenarios. The back-up range extender (BUREX) concept described in the article is a very cost-effective REX that requires a relatively small installation volume. Because REX technologies are seen as short-term solutions to be used until FC systems become more mature and cost-effective, the BUREX design is attractive since it uses existing technologies and is relatively straightforward to implement. It has the notable drawback that it can only be used outside the driving cycle, but it still provides redundancy for BEVs that must be used in rural areas where external charging stations are scarce.

5. Conclusions

A heavy-duty BEV truck with a total installation volume for the powertrain of 3 m³ can store up to 970 kWh. This energy is sufficient for 27% of all possible use cases for the Scania HD fleet considering one recharging event per day.

The BUREX system makes 50–60% more electric energy available in the same installation volume and can manage 55% of all possible use cases utilized 20 days per year.

The BUREX concept is a very good option for customers who do not want to pay extra money for a large enough battery to cover only a very few extra energy-demanding uses cases each year.

The BUREX system reduces life-cycle CO₂ emissions, irrespective of the generation mix of the grid supplying the electricity used in vehicle manufacturing and battery charging.

The BUREX system compared to a IUREX has room for more batteries and is more cost effective.

The BUREX system is considered to improve the redundancy for heavy-duty BEV in the short term when recharging systems and infrastructure are developed. This is especially important in rural regions in combination with extreme weather conditions.

Both BUREX and IUREX are considered short-term solutions while the FC matures in terms of cost and size and a clearer understanding is formed about hydrogen infrastructure.

REX and FC technologies both add redundancy to the BEV concept, which is needed while fuel cell and electric powertrain technologies are maturing and the infrastructure for external charging is still being constructed. The BUREX concept studied here increases the range of HD BEVs and the proportion of the HD truck fleet that can be electrified while also reducing life-cycle CO₂ emissions, irrespective of the generation mix of the grid supplying the electricity used in vehicle manufacturing and battery charging. Importantly, the BUREX solution is also much more cost-effective than alternative range-extending concepts such as IUREX and requires a lower installation volume, leaving more space available for batteries.

Author Contributions: Conceptualization ICE: L.Z. (ICE), P.S. (FC), H.S. (analyzes REX/FC); methodology: L.Z., H.S., P.S.; software: Gamma Technology, Matlab, Excel; supervision: P.D. All authors have read and agreed to the published version of the manuscript.

Funding: Combustion Engine Research Chalmers.

Data Availability Statement: Not applicable.

Conflicts of Interest: Lennarth Zander (main author), Pontus Svens (co-author), and Henrik Svård (co-author) are employed at Scania CV. The paper reflects the view of the scientists, and not the company. The authors declare no conflict of interest.

Definitions/Abbreviations

BUREX	Back-up range extender
REX	Range extender
IUREX	In-use range extender
FC	Fuel cell
BEV	Battery electric vehicle
PTO	Power take-off
ICE	Internal combustion engine
BSFC	Brake-specific fuel consumption
CI engine	Compression ignition engine
SI engine	Spark ignition engine
MGU	Power electronic unit or inverter
H ₂	Hydrogen
EM	Electric machine

References

1. "Lead the Way to a Low-Carbon Future". Science Based Targets Initiative. Available online: <https://sciencebasedtargets.org/how-it-works> (accessed on 22 March 2022).
2. Skidmore, Z. Electric Vehicle Sales Surge in 2021. Available online: <https://www.power-technology.com/news/electric-vehicle-sales-surge-in-2021/> (accessed on 22 March 2022).
3. Pierri, E.; Cirillo, V.; Vietor, T.; Sorrentino, M. Adopting a Conversion Design Approach to Maximize the Energy Density of Battery Packs in Electric Vehicles. *Energies* **2021**, *14*, 1939. [CrossRef]
4. Mauler, L.; Duffner, F.; Zeier, W.G.; Leker, J. Battery cost forecasting: A review of methods and results with an outlook to 2050. *Energy Environ. Sci.* **2021**, *14*, 4712–4739. [CrossRef]
5. Chubbock, S.; Clague, R. Comparative analysis of internal combustion engine and fuel cell range extender. *SAE Int. J. Altern. Powertrains* **2016**, *5*, 175–182. [CrossRef]
6. Lohse-Busch, H.; Stutenberg, K.; Duoba, M.; Liu, X.; Elgowainy, A.; Wang, M.; Christenson, M. Automotive fuel cell stack and system efficiency and fuel consumption based on vehicle testing on a chassis dynamometer at minus 18 degrees C to positive 35 degrees C temperatures. *Int. J. Hydrog. Energy* **2020**, *45*, 861–872. [CrossRef]
7. Turner, J.; Blake, D.; Moore, J.; Burke, P.; Pearson, R.; Patel, R.; Card, C. The Lotus Range Extender Engine. *Sae Int. J. Engines* **2010**, *3*, 318–351. [CrossRef]
8. Bassett, M.; Hall, J.; Darkes, D.; Fraser, N.; Warth, M.; Imech, E. Design and development of a dedicated range extender engine. In *Internal Combustion Engines: Improving Performance, Fuel Economy and Emission*; ResearchGate: Berlin, Germany, 2011; pp. 3–12. [CrossRef]
9. Bassett, M.; Hall, J.; Cains, T.; Taylor, G.; Warth, M. Development of a range extended electric vehicle demonstrator. *Sustain. Veh. Technol. Driv. Green Agenda* **2012**, *191*, 205–213.
10. Rust, A.; Graf, B.J. NVH of Electric Vehicles with Range Extender. *Sae Int. J. Passeng. Cars-Mech. Syst.* **2010**, *3*, 860–867. [CrossRef]
11. Hubmann, C.; Beste, F.; Friedl, H.; Schoffmann, W. Single cylinder 25kW range extender as alternative to a rotary engine maintaining high compactness and NVH performance. *SAE Tech. Pap.* **2013**. [CrossRef]
12. Hubmann, C.; Friedl, H.; Gruber, S.; Foxhall, N. Single Cylinder 25kW Range Extender: Development for Lowest Vibrations and Compact Design Based on Existing Production Parts. *SAE Tech. Pap.* **2015**. Available online: <https://www.sae.org/publications/technical-papers/content/2015-32-0740/> (accessed on 8 May 2022).
13. Nuccio, P.; De Donno, D.; Magno, A. Development through simulation of a turbocharged 2-stroke GDI engine focused on a range-extender application. *SAE Tech. Pap.* **2017**. Available online: <https://www.sae.org/publications/technical-papers/content/2017-32-0121/> (accessed on 8 May 2022).
14. Zander, L.; Dahlander, P. Analysis of a Turbocharged Single-Cylinder Two-Stroke SI Engine Concept. *SAE Tech. Pap.* **2021**. [CrossRef]
15. Pischinger, M.; Tomazic, D.; Wittek, K.; Esch, H.-J.; Köhler, E.; Baehr, M. A low NVH range-extender application with a small V-2 engine-based on a new vibration compensation system. *SAE Tech. Pap.* **2012**. [CrossRef]
16. Duret, P.; Venturi, S.; Sciarretta, A.; Foxhall, N.; Hinterberger, W. Potential of a Production DI Two-Stroke Engine Adapted for Range Extender and Motorcycle Applications. *SAE Tech. Pap.* **2017**. [CrossRef]
17. Agarwal, A.; Lewis, A.; Brace, C.; Akehurst, S. Development of a low cost production automotive engine for range extender application for electric vehicles. *Tech. Pap.* **2016**. Available online: <https://www.sae.org/publications/technical-papers/content/2016-01-1055/> (accessed on 8 May 2022).
18. Zander, L. Simulation Study of a Turbocharged Two-Stroke Single Cylinder 425cc SI Engine. *SAE Tech. Pap.* **2021**. [CrossRef]
19. Cano, Z.P.; Banham, D.; Ye, S.; Hintennach, A.; Lu, J.; Fowler, M.; Chen, Z. Batteries and fuel cells for emerging electric vehicle markets. *Nat. Energy* **2018**, *3*, 279–289. [CrossRef]
20. USCAR. EV Battery Goals. Available online: https://uscar.org/wpfd_file/ev-battery-goals/ (accessed on 1 March 2022).

21. Pei, M.; Petäjäniemi, M.; Regnell, A.; Wijk, O. Toward a fossil free future with HYBRIT: Development of iron and steelmaking technology in Sweden and Finland. *Metals* **2020**, *10*, 972. [[CrossRef](#)]
22. Philippot, M.; Alvarez, G.; Ayerbe, E.; van Mierlo, J.; Messagie, M. Eco-Efficiency of a Lithium-Ion Battery for Electric Vehicles: Influence of Manufacturing Country and Commodity Prices on GHG Emissions and Costs. *Batteries* **2019**, *5*, 23. [[CrossRef](#)]
23. Benitez, A.; Wulf, C.; de Palmaer, A.; Lengersdorf, M.; Röding, T.; Grube, T.; Kuckshinrichs, W. Ecological assessment of fuel cell electric vehicles with special focus on type IV carbon fiber hydrogen tank. *J. Clean. Prod.* **2021**, *278*, 123277. [[CrossRef](#)]
24. Hoekstra, A. Producing Gasoline and Diesel Emits More CO₂ than We Thought. Available online: <https://innovationorigins.com/en/producing-gasoline-and-diesel-emits-more-co2-than-we-thought/> (accessed on 2 March 2022).
25. Jokiniemi, T. Greenhouse Gas Emissions from Direct Combustion of Various Fuels. University of Helsinki. Available online: https://enpos.weebly.com/uploads/3/6/7/2/3672459/co2_direct_combustion_jokiniemi.pdf#:~:text=Example%3A%20carbon%20content%20of%20diesel%20fuel%20is%2085%2C7,%3D%2073%2C6%20g%2FMJ%20Calculated%20CO2emissions%20from%20different%20fuels (accessed on 2 March 2022).
26. Guduru, R.K.; Tummala, R. Are Electric Vehicles Really Greener than Internal Combustion Engine Vehicles? Available online: <https://medium.com/batterybits/are-electric-vehicles-really-greener-than-internal-combustion-engine-vehicles-71b35396a4df> (accessed on 2 March 2022).
27. Hydrogen Fuel Cell Vehicle Technology Roadmap. SAE China. Available online: <http://www.sae-china.org/download/1896/Hydrogen+Fuel+Cell+Vehicle+Technology+Roadmap+%E6%B0%A2%E7%87%83%E6%96%99%E7%94%B5%E6%B1%A0%E6%B1%BD%E8%BD%A6%E6%8A%80%E6%9C%AF%E8%B7%AF%E7%BA%BF%E5%9B%BE.pdf> (accessed on 30 June 2021).
28. James, B.D.; Houchins, C. 700 Bar Type IV H₂ Pressure Vessel Cost Projections. US DOE. Available online: https://www.energy.gov/sites/prod/files/2016/09/f33/fcto_h2_storage_700bar_workshop_2_james.pdf (accessed on 2 March 2022).
29. How Competitive is Biofuel Production in Brazil and the United States? International Energy Agency. Available online: <https://www.iea.org/articles/how-competitive-is-biofuel-production-in-brazil-and-the-united-states> (accessed on 24 May 2022).