



A Real-Valued 4D Memory Polynomial Algorithm for Mixer Modeling

Downloaded from: <https://research.chalmers.se>, 2026-04-05 18:27 UTC

Citation for the original published paper (version of record):

Hajiabdollahi, N., Wang, S., Fager, C. et al (2021). A Real-Valued 4D Memory Polynomial Algorithm for Mixer Modeling. 2021 51st European Microwave Conference, EuMC 2021: 325-328. <http://dx.doi.org/10.23919/EuMC50147.2022.9784179>

N.B. When citing this work, cite the original published paper.

A Real-Valued 4D Memory Polynomial Algorithm for Mixer Modeling

Nima Hajiabdolrahim^{#1}, Siqi Wang^{#2}, Christian Fager^{#3}, Halil Volkan Hünlerli^{*4}, Thomas Eriksson^{#5}

[#]Chalmers University of Technology, Sweden

^{*}Ericsson, Sweden

{¹nimahaj, ²siqiw, ³christian.fager, ⁵thomase}@chalmers.se, ⁴ halil.volkan.hunerli@ericsson.com

Abstract— In this paper, we propose a real-valued multi-input memory polynomial (MP) for behavioral modeling of a mixer, which considers nonlinearity introduced by in-phase, quadrature and the local oscillator (LO) inputs. By splitting the I and Q data of the stimulus and LO signal, we use a 4-input 2-output structure of the real-valued MP model. The experimental validation based on data measured from a real mixer confirms the effectiveness of our proposed model. Compared with the Volterra series in the literature, the real-valued MP has similar modeling accuracy with much lower complexity.

Keywords— IQ imbalance, local oscillator, mixer modeling, memory polynomial, nonlinearity.

I. INTRODUCTION

Mixers are fundamental parts of any wireless communication link. Their performance can highly influence the overall performance of the system. In the ideal case, one may expect that mixer works as a perfect multiplier followed by a band-pass filter, which means getting the products of the input signals of a mixer at its output. However, in most practical mixers the actual output signal diverges from the expected signal, which is mainly caused by non-ideal behaviour of the mixer. Thus, developing a comprehensive model for a mixer that can predict its non-ideal behaviour is a crucial step in designing communication links.

There are two main approaches in mixer modeling, circuit-level modeling [1], [2] and behavioral system modeling. Behavioral modeling is more imperative from communication system design point of view, so in this paper we focus on this kind of model. In behavioral modeling procedure, the internal structure of the mixer is disregarded, and the model is created based on the mixer's external parameters and measured data [3].

There have been many previous works and researches on mixer modeling. In [4] a model for single-frequency standard and image mixers is provided, but no non-linear effect is considered in their model. A model for the non-linear behavior of a mixer is given in [5], where the possible non-linear effects of the local oscillator signal is ignored. In [6] an approach based on Volterra series is presented to model the non-linear behavior of a mixer for a simplified structure of the input signal, however the provided model does not represent the effect of memory in the mixer. It is remarkable that according to the study provided in [7], the memory effect of a mixer can influence the overall performance of the mixer considerably

at some frequencies, so including memory in a mixer model is important. In [8] a general real model is provided for I/Q modulators and demodulators based on Volterra series expansion, which covers both the non-linear effect and memory effect, but since the presented model is more an I/Q modulator model rather than mixer model, it does not include the effects of local oscillator signal. In a recent work, Ozgun et al. have proposed a multi-box mixer model in [9], where the non-linear effect of different inputs and their memory effect are considered in different boxes. Although the model provided in [9] is more general, but it still does not include the memory effect of the local oscillator signal and the possible leakages from local oscillator signal to the mixer output.

In this paper we propose a real-valued model for a mixer based on a 4-dimensional memory polynomial. The main benefits of the proposed mixer model to the previous models, which are also the main contributions of this paper, can be listed as follows:

- It includes all the possible non-linearity effects and memory effects of all input signals on the mixer output signal. Specifically, it can model all the possible effects of the local oscillator signal on the mixer output signal.
- It is based on the memory polynomial algorithm, which makes it computationally less complex than models using Volterra structure.

The remaining of the paper is structured as follows: our proposed model is introduced in section II, the simulation results based on a set of measured data are presented in section III, and finally in section IV we conclude our work.

II. PROPOSED MODEL

First of all, we know that mixer is a 3-port block with two input signals and one output signal [1], where one of the input signals is always the local oscillator (LO) signal (an RF signal). Based on the working regime of a mixer, the other input signal and the output signal can be IF or RF signals. Based on the analysis in [10], we can consider the base-band equivalent signals of the input and output signals without any loss of generality, which means that we can observe all kinds of non-linear behaviours in the performance of a mixer.

Our proposed mixer model structure is depicted in Figure 1. In Fig. 1 the base-band input signal, the LO signal and the output signal of the mixer are denoted by $x[n]$, $s[n]$ and $y[n]$, respectively. As illustrated in Fig. 1, $y_I[n]$

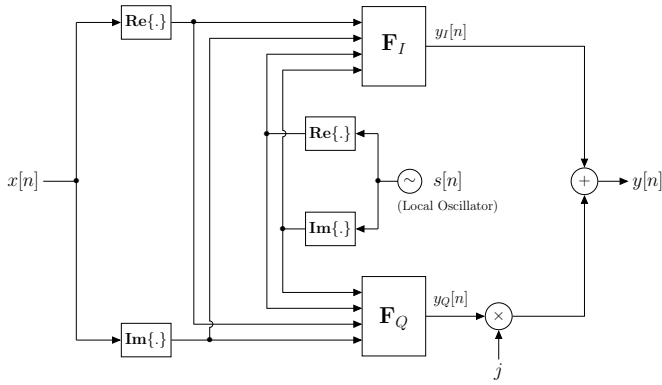

Fig. 1. Proposed structure for modeling a mixer.

and $y_Q[n]$ are the in-phase and quadrature components of $y[n]$, which means that $y[n] = y_I[n] + jy_Q[n]$. It is worth re-mentioning that $x[n]$, $s[n]$ and $y[n]$ are all complex-valued base-band signals which are the base-band equivalents of corresponding input and output signals of the mixer. F_I and F_Q are independent non-linear blocks which are implemented to model the non-linear behaviours in the in-phase and quadrature branches, respectively. Both F_I and F_Q are real-valued functions with 4 arguments. Note that the LO signal is included as an input to the non-linear blocks, thus they would be able to model the non-linearity in the mixer output signal caused by the LO signal.

We propose a real-valued 4 dimensional memory polynomial (Real 4D MP) for mixer modeling [11]. Therefore, $y_I[n]$ and $y_Q[n]$ can be expressed as follows

$$y_I[n] = F_I(x_r[n], x_i[n], s_r[n], s_i[n]) \quad (1)$$

$$= \sum_{m=0}^{M_I} \sum_{\substack{p_1=0 \\ p_1+p_2+p_3+p_4 \leq P_I}}^{P_{x,I}^r} \sum_{p_2=0}^{P_{x,I}^i} \sum_{p_3=0}^{P_{s,I}^r} \sum_{p_4=0}^{P_{s,I}^i} a(m, p_1, p_2, p_3, p_4) \times \\ \left(x_r^{p_1}[n-m] x_i^{p_2}[n-m] s_r^{p_3}[n-m] s_i^{p_4}[n-m] \right),$$

$$y_Q[n] = F_Q(x_r[n], x_i[n], s_r[n], s_i[n]) \quad (2)$$

$$= \sum_{m=0}^{M_Q} \sum_{\substack{p_1=0 \\ p_1+p_2+p_3+p_4 \leq P_Q}}^{P_{x,Q}^r} \sum_{p_2=0}^{P_{x,Q}^i} \sum_{p_3=0}^{P_{s,Q}^r} \sum_{p_4=0}^{P_{s,Q}^i} b(m, p_1, p_2, p_3, p_4) \times \\ \left(x_r^{p_1}[n-m] x_i^{p_2}[n-m] s_r^{p_3}[n-m] s_i^{p_4}[n-m] \right).$$

The parameters a and b are real coefficients, $x_r[n]$ and $x_i[n]$ are real and imaginary parts of input signal $x[n]$, respectively, $s_r[n]$ and $s_i[n]$ are real and imaginary parts of LO signal $s[n]$, respectively, and M_I and M_Q are memory depth in the in-phase and quadrature branches, $P_{x,I}^r$ and $P_{x,I}^i$ are non-linearity orders of real and imaginary parts of $x[n]$ in in-phase branch, $P_{s,I}^r$ and $P_{s,I}^i$ are non-linearity orders of real and imaginary parts of $s[n]$ in in-phase branch, $P_{x,Q}^r$

and $P_{x,Q}^i$ are non-linearity orders of real and imaginary parts of $x[n]$ in quadrature branch, $P_{s,Q}^r$ and $P_{s,Q}^i$ are non-linearity orders of real and imaginary parts of $s[n]$ in quadrature branch, respectively. Moreover, we have assumed that the maximum total non-linearity order of the in-phase and quadrature branches are equal to P_I and P_Q , respectively, hence constraints are placed on the terms under summation in equations (1) and (2).

In order to characterize the proposed Real 4D MP model completely, we need to specify its main parameters, including M_I , M_Q , $P_{x,I}^r$, $P_{x,I}^i$, $P_{s,I}^r$, $P_{s,I}^i$, $P_{x,Q}^r$, $P_{x,Q}^i$, $P_{s,Q}^r$, $P_{s,Q}^i$, P_I , P_Q and the real coefficients of a and b in (1) and (2). First we set the memory depths and the non-linearity orders equal to some initial values, then after estimating the a and b coefficients and evaluating the model performance we can modify the initial values of the parameters to improve the accuracy of our model. Next, we consider the output signal of the mixer ($\tilde{y}[n]$) to the known input signals $\tilde{x}[n]$ and $\tilde{s}[n]$ for $n = 1, 2, \dots, N$. Now, we can rewrite (1) and (2) in the vector forms of $\tilde{\mathbf{y}}_I = \mathbf{H}\mathbf{a}$ and $\tilde{\mathbf{y}}_Q = \mathbf{H}\mathbf{b}$, where $\tilde{\mathbf{y}}_I = [\tilde{y}_I[1] \ \tilde{y}_I[2] \ \dots \ \tilde{y}_I[N]]^T$ and $\tilde{\mathbf{y}}_Q = [\tilde{y}_Q[1] \ \tilde{y}_Q[2] \ \dots \ \tilde{y}_Q[N]]^T$ are $N \times 1$ known vectors, $\mathbf{a} = [a(1) \ a(2) \ \dots \ a(K)]^T$ and $\mathbf{b} = [b(1) \ b(2) \ \dots \ b(K)]^T$ are $K \times 1$ unknown coefficient vectors, where K is the number of coefficients that we want to estimate and is equal to the number of terms under summation in (1) or (2), and \mathbf{H} is a $N \times K$ matrix whose columns are the basis functions of \tilde{y}_I and \tilde{y}_Q in (1) and (2) and since $\tilde{x}[n]$ and $\tilde{s}[n]$ are known signals, \mathbf{H} would also be a known matrix. Finally, the least squares (LS) estimates of the coefficient vectors are equal to

$$\hat{\mathbf{a}} = \mathbf{H}^\dagger \tilde{\mathbf{y}}_I = (\mathbf{H}^T \mathbf{H})^{-1} \mathbf{H}^T \tilde{\mathbf{y}}_I, \quad (3)$$

$$\hat{\mathbf{b}} = \mathbf{H}^\dagger \tilde{\mathbf{y}}_Q = (\mathbf{H}^T \mathbf{H})^{-1} \mathbf{H}^T \tilde{\mathbf{y}}_Q. \quad (4)$$

In (3) and (4), \mathbf{H}^\dagger is the pseudo inverse of the non-squared matrix \mathbf{H} and $\mathbf{H}^\dagger \mathbf{H} = \mathbf{I}_K$.

We should notice that the main difference between the proposed Real 4D MP model and the truncated Volterra model [12] is that the crossed terms between the terms with different memories are not included in (1) and (2), so the number of coefficients required to generate a model in our proposed structure is considerably lower than the required coefficients in Volterra structure. Therefore, the complexity of the proposed structure would be much lower than the structures using Volterra series.

The other advantage of Real 4D MP model is its robustness to the further phase distortion that may appear at the output of a mixer. Since the proposed model is a real-valued model, it would make it possible to track the non-linearity behaviour of the mixer even in presence of an unknown source of phase distortion in the system.

III. ANALYSIS OF MEASURED DATA

In this section we evaluate the performance of Real 4D MP model with measured data. An E2-band direct conversion

transmitter (Gotmic gTSC0025) was used for the experimental studies, using the setup illustrated in Fig. 2 [13].

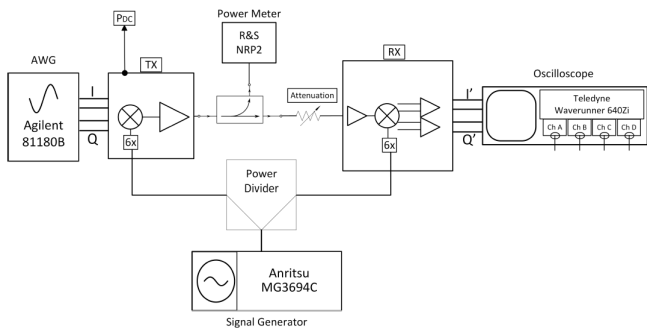

Fig. 2. Experimental setup for characterization of E-band I/Q mixer.

The transmitter's differential baseband I/Q inputs are provided by a two-channel arbitrary waveform generator (Agilent 81180B). In order to characterize the modulated RF output signal, an E-band receiver was used. Using the receiver, the RF signal is downconverted to baseband and saved in time domain with an oscilloscope (LeCroy Waverunner 640Zi). A carefully selected attenuator, placed between the transmitter and receiver, is used to guarantee that the receiver operates in linear mode and its contribution to amplitude and phase compression is minimal. The non-ideal effects observed at the the oscilloscope end connected to the differential I/Q outputs of the receiver are, therefore, an accurate representation of the transmitter effects. It is important to note that both the receiver and transmitter use the same LO source (Anritsu MG3694C) which eliminates the need for phase and frequency tracking during the measurements. The measurements have been performed at an RF frequency of 84 GHz using a 192 Mbaud 256-QAM signal.

Note that in the experiments we did not have access to the LO signal, so no validation of the LO input could be performed. However, we could adapt the Real 4D-MP model to the measured data to track the non-linear behaviour of the mixer. In future experiments, we expect to also measure the LO signal.

In addition to the Real 4D-MP model, we have also considered a truncated Volterra (TV) model including all the cross terms between input signals with different memories in this section.

The results from implementation of the proposed model to the measured data are presented in Table 1. In order to develop our models, we have used the first part of the measured data as training sequence, where we have estimated the coefficients in (1) and (2) based on the measured $x[n]$ and $y[n]$, which are denoted by \hat{a} and \hat{b} . In the evaluation phase we used the extracted values of the coefficients to generate the estimated $\hat{y}[n]$ for the remaining part of the measured data, which is the evaluating sequence. In the next step, we have compared measured $y[n]$ and estimated $\hat{y}[n]$ by calculating the

Table 1. Parameters set for adapting the Real 4D MP model and Truncated Volterra model to the measured data set.

	Real 4D MP model	Truncated Volterra model
Length of training sequence	10000	10000
Length of evaluating sequence	6000	6000
Memory depth	3	3
Non-linearity order of $s[n]$	0	0
Maximum non-linearity order of in-phase branch	5	5
Maximum non-linearity order of quadrature branch	5	5
Non-linearity order of $x_r[n]$	5	5
Non-linearity order of $x_i[n]$	5	5
Number of coefficients	2×84	2×201
NMSE	-35.11 dB	-35.68 dB

normalized mean squared error (NMSE) value in dB, which is defined as follows

$$\text{NMSE} = 10 \log_{10} \left(\frac{\mathbb{E} [|y[n] - \hat{y}[n]|^2]}{\mathbb{E} [|y[n]|^2]} \right). \quad (5)$$

It's noteworthy that for a specific signal we have assumed the same memory depths and non-linearity orders in in-phase and quadrature branches in Table 1. Furthermore, with the assumed values of memory depths and non-linearity orders in Table 1, there will be 84 coefficients for F_I block and 84 coefficients for F_Q block in the structure of Fig. 1 and the total number of coefficients would be equal to 2×84 in Real 4D MP model, while the total number of coefficients is 2×201 in TV model.

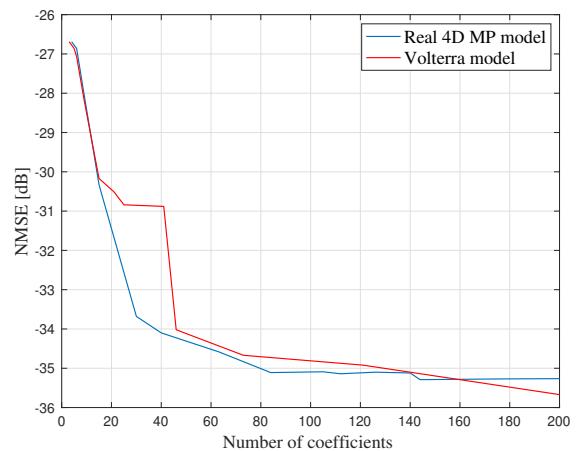

Fig. 3. NMSE values in dB for Real 4D MP models and Volterra models with different parameter sets with different number of coefficients.

The amount of memory depth and non-linearity order in Table 1 are selected according to Fig. 3. In this figure the value of NMSE in dB for the Real 4D MP model and Volterra model are plotted versus number of coefficients that is used for modeling F_I in (1) or F_Q in (2), for different values of memory depths and non-linearity orders, which has been generated by applying Pareto Front algorithm [14]. As illustrated in Fig. 3, if we use less than 84 coefficients for modeling F_I or F_Q , we

can not achieve the NMSE value of less than -35 dB, and if we use more than 84 coefficients we will not get a much better performance but we will increase the complexity of our model. Therefore, the optimal number of coefficients for modeling F_I or F_Q is 84 coefficients in this case, which is obtained by setting the memory depth equal to 3 and assuming the non-linearity order of 5. Moreover, it is clear in Fig. 3 that the proposed Real 4D MP model has lower complexity than Volterra model for a fixed target NMSE value.

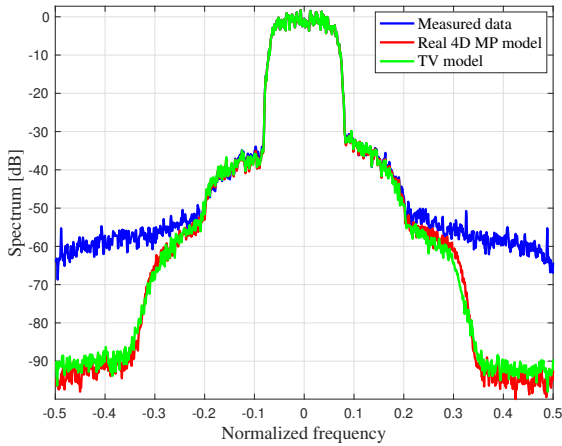

Fig. 4. Spectrum of the measured data, the Real 4D MP model and the Truncated Volterra (TV) model.

The spectrum of the Real 4D MP model and TV model and also the spectrum of the error for these two models are represented in Fig. 4 and 5, respectively. It can be observed from Fig. 4 and 5 that the proposed Real 4D MP model can achieve the same level of accuracy as truncated Volterra model with lower complexity level.

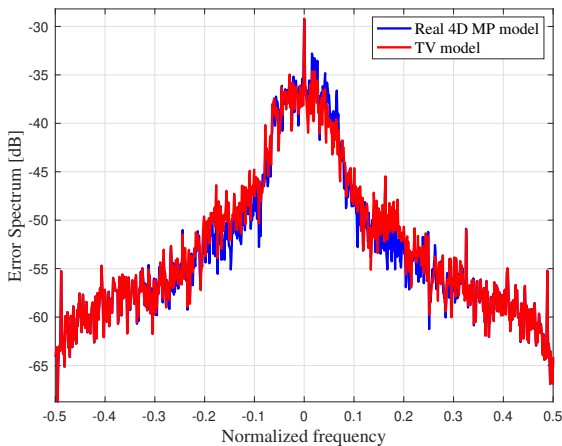

Fig. 5. Spectrum of the error in Real 4D MP model and Truncated Volterra (TV) model.

IV. CONCLUSION

In this paper, a Real 4D MP model has been proposed for modeling a mixer, which is able to track the nonlinear

behaviour at the output of a mixer as a function of input signal and LO signal. It can also model the memory effects of the mixer. With the same level of modeling accuracy, the Real 4D MP model has much less basis functions than the conventional Volterra series, which validates that our proposed contains the most important basis functions. More studies need to be done in the future to reduce the model complexity.

ACKNOWLEDGEMENT

This research has been carried out in the GigaHertz Centre in two joint projects financed by the Swedish Government Agency for Innovation Systems (VINNOVA), Chalmers University of Technology, Ericsson, Gotmic, Infineon Technologies Austria, Qamcom, RISE, RUAG, and SAAB.

REFERENCES

- [1] S. A. Maas, "Microwave mixers," *Norwood*, 1986.
- [2] M. J. Rosário and J. C. Freire, "A design technique for mesfet mixers based on spice program," in *IEEE International Digest on Microwave Symposium*. IEEE, 1990, pp. 331–334.
- [3] J. Liu, L. P. Dunleavy, and T. B. Svensen, "A table-based asymmetric system mixer model," in *European Microwave Conference*, 2003.
- [4] D. F. Williams, F. Ndagijimana, K. A. Remley, J. A. Dunsmore, and S. Hubert, "Scattering-parameter models and representations for microwave mixers," *IEEE transactions on microwave theory and techniques*, vol. 53, no. 1, pp. 314–321, 2005.
- [5] K. Vandermot, W. Van Moer, J. Schoukens, and Y. Rolain, "Understanding the nonlinearity of a mixer using multisine excitations," in *2006 IEEE Instrumentation and Measurement Technology Conference Proceedings*. IEEE, 2006, pp. 1205–1209.
- [6] M. Goffioul, P. Wambacq, G. Vandersteen, and S. Donnay, "Analysis of nonlinearities in rf front-end architectures using a modified volterra series approach," in *Proceedings 2002 Design, Automation and Test in Europe Conference and Exhibition*. IEEE, 2002, pp. 352–356.
- [7] B. Zhang, L. Tong, B. Gao, B. Yang, S. Li, S. Liang, and F. Nian, "A study on the memory effect of mixer," in *2020 IEEE Radar Conference (RadarConf20)*. IEEE, 2020, pp. 1–5.
- [8] H. Cao, A. S. Tehrani, C. Fager, T. Eriksson, and H. Zirath, "Iq imbalance compensation using a nonlinear modeling approach," *IEEE Transactions on Microwave Theory and Techniques*, vol. 57, no. 3, pp. 513–518, 2009.
- [9] A. Ozgun, T. Nesimoglu, and S. Demir, "A multi-box behavioural mixer model and its validation using measurements," in *2019 IEEE MTT-S International Microwave Symposium (IMS)*. IEEE, 2019, pp. 607–610.
- [10] O. Tanovic, A. Megretski, Y. Li, V. Stojanovic, and M. Osqui, "Equivalent baseband models and corresponding digital predistortion for compensating dynamic passband nonlinearities in phase-amplitude modulation-demodulation schemes," *IEEE Transactions on Signal Processing*, vol. 66, no. 22, pp. 5972–5987, 2018.
- [11] D. R. Morgan, Z. Ma, J. Kim, M. G. Zierdt, and J. Pastalan, "A generalized memory polynomial model for digital predistortion of rf power amplifiers," *IEEE Transactions on signal processing*, vol. 54, no. 10, pp. 3852–3860, 2006.
- [12] F. J. Doyle, R. K. Pearson, and B. A. Ogunnaike, *Identification and control using Volterra models*. Springer, 2002.
- [13] H. V. Hünerli, "Transmitter linearization for mm-wave communications systems," Ph.D. dissertation, Chalmers University of Technology, Department of Microtechnology and Nanoscience, 2021.
- [14] X.-B. Hu, M. Wang, and E. Di Paolo, "Calculating complete and exact pareto front for multiobjective optimization: a new deterministic approach for discrete problems," *IEEE Transactions on cybernetics*, vol. 43, no. 3, pp. 1088–1101, 2013.