



Heat distribution concepts for small solar district heating systems – Techno-economic study for low line heat densities

Downloaded from: <https://research.chalmers.se>, 2026-04-04 17:46 UTC

Citation for the original published paper (version of record):

Andersen, M., Bales, C., Dalenbäck, J. (2022). Heat distribution concepts for small solar district heating systems – Techno-economic study for low line heat densities. *Energy Conversion and Management*: X, 15.
<http://dx.doi.org/10.1016/j.ecmx.2022.100243>

N.B. When citing this work, cite the original published paper.



Heat distribution concepts for small solar district heating systems – Techno-economic study for low line heat densities

Martin Andersen^{a,b,*}, Chris Bales^a, Jan-Olof Dalenbäck^b

^a Solar Energy Research Center (SERC), Dalarna University, Borlänge, Sweden

^b Chalmers University of Technology, Gothenburg, Sweden

ARTICLE INFO

Keywords:

4GDH
Solar thermal
District heat
Hot water circulation
GRUDIS
TRNSYS

ABSTRACT

The high operating temperatures in today's district heating networks combined with the low energy demand of new buildings lead to high relative network heat losses. New networks featuring lower operating temperatures have reduced relative heat losses while enabling an increase in the use of solar heat. The primary aim of this study was to determine if a particular district heating system can be made more effective with respect to heat losses and useful solar energy, by considering different distribution concepts and load densities. A small solar assisted district heating system with a novel hybrid distribution system has been modelled based on a real case study. This model serves as a basis for two other models where the distribution system and heating network operating temperature is changed. A secondary aim of the study was to determine the economic implications of making these changes, by using costs estimates to calculate the contribution of essential system components to total system cost. Results indicate that a novel distribution concept with lower network temperatures and central domestic hot water preparation is most energy efficient in a sparse network with a heat density of 0.2 MWh/m²•a and a performance ratio of 66%, while a conventional district heating system performs worst and has a performance ratio of less than 58% at the same heat density. In an extremely sparse network with heat density of 0.05 MWh/m²•a, the performance ratio is 41% and 30% for these systems, respectively. A simple economic analysis indicates that the novel distribution concept is also best from an economic point of view, reducing the initial investment cost by 1/3 compared to the conventional concept, which is the most costly. However, more detailed calculations are needed to conclude on this.

Introduction

This introduction provides some background for, disseminates the work preceding, and outlines the aim and scope for, this study.

Background

Many governments around the world have set goals for the renewable energy shares of the national energy demand in order to protect the local environment, increase energy access, increase resource efficiency

and improve long-term economics. SH and DHW demands account for more than 50% of the European residential sector energy demand [1]. Due to the low temperature requirement of these heating processes, solar thermal (ST) collectors are well suited as a heat supply source. However, so far, more than 90% of installed ST capacity is used for DHW preparation in single-family houses and larger hot water systems in residential areas or the public sector and by the end of 2018, only about 3% of all installed ST capacity in Europe was utilised in large scale systems (e.g. for DH) [2]. In 2015, 12% of the EU28 heat demand came from DH, whereby only a marginal share was supplied by solar thermal

Abbreviations: BC, Boiler Central; CW, Cold Water; CHP, Combined Heat and Power; DH, District Heat(ing); DHW, Domestic Hot Water; DHWC, DHW Circulation; DN, Nominal Diameter; EPS, Extruded Polystyrene; EPSPEX, EPS encased PEX pipes; ETC, Evacuated Tube Collector(s); EUR, Euro; FEM, Finite Element Method; FPC, Flat Plate Collector(s); GRUDIS, Swedish acronym for "Gruppcentraldistributionssystem"; HVAC, Heating, Ventilation and Cooling; LD, Line(ar) Heat Density; LCA, Life Cycle Assessment; PEX, Cross-linked Polyethylene; PR, Performance Ratio; SDH, Solar district heating; SEK, Swedish Krone(s); SF, Solar Fraction; SH, Space Heating; SS, Substation; SS-EN, Swedish Standard - Engineering Norm; ST, Solar Thermal; TMY, Typical Meteorological Year; GM, Ground Mounted; NUSE, Net Utilised Solar Energy.

* Corresponding author at: Högskolan Dalarna, 791 88 Falun, Sweden.

E-mail address: maar@du.se (M. Andersen).

<https://doi.org/10.1016/j.ecmx.2022.100243>

Received 3 May 2021; Received in revised form 5 April 2022; Accepted 4 June 2022

Available online 8 June 2022

2590-1745/© 2022 The Author(s). Published by Elsevier Ltd. This is an open access article under the CC BY license (<http://creativecommons.org/licenses/by/4.0/>).

[1]. By the end of 2018, renewable energy accounted for 21% of the total energy used for heating and cooling in the EU [3], although less than 2% of the thermal energy demand in buildings was covered by solar thermal [4].

However, economic viability of DH depends on heat demand density, which explains why historically it has been favoured in urban environments and only occasionally employed in rural and suburban areas. Nowadays, new building codes are adapted around the world [5] and as the heat demand of the future building stock is set to decrease, the line heat density (LD) of DH networks is expected to decrease along with it. Using today's DH technology to supply future demands, distribution heat losses are expected to significantly increase in relative proportion to the heating demand, which reduces the competitiveness of DH versus other heating methods. This challenge, among others, has been outlined together with the need for research efforts to identify the most efficient distribution options available and to establish the potential role of DH in the future sustainable energy system [6]. Some efforts have been made to identify concrete improvements in the future DH system, although studies providing real use cases implementing these improvements are still needed [7].

Small DH networks are sometimes called block-heating systems. The integration of a ST system into a block heating network can be a cost-effective solution, especially for new low-energy residential areas [8]. Because of this, many new and small solar district heating (SDH) systems are built at the same time as the buildings, allowing for a more holistic approach to the design and construction. When the distribution network and the collectors are designed and built at the same time as the building area, it is possible to optimise the integration of the ST system with respect to both cost and technical layout [9]. One example of this is found in a new residential area Vallda Heberg, finished in 2013, which was based on previous experiences in building small renewable DH systems. The intention was to make a system whose SF was higher than ever before and at the same time being economical, using lower operating temperatures and a cheaper distribution system. All residential units have well insulated envelopes with mechanical ventilation and heat recovery to reduce heat demand. Heat is supplied by a small DH system with a pellet boiler and ST [10].

The Vallda Heberg system has several innovative features related to the distribution system that have been highlighted in [11] and this study is based on these innovative features, but was adapted to make the results more general. This was done by simplifying the system in two particular ways; changing network structure to supply only one type of housing, as well as resizing the network to supply equally sized housing areas. The intention behind this was to focus on the distribution system and to make its advantages stand out more clearly.

Previous work

Early studies into SDH concluded that large SF was not only technically feasible, but was about to be economically feasible at particular locations [12]. Subsequent research studies have evaluated the economic feasibility of SDH with regards to short-term and long-term storage and concluded that the energy price with long-term storage was generally higher than that with short-term storage. Moreover, short-term storage was supposedly only suitable for SF of 10–15% and integration was most cost effective when the ST system was built at the same time as the buildings [8].

Normally, SDH systems with diurnal storage employ insulated steel tanks and have a design SF of around 20%, delivering 80%–100% of the DHW load in the summer months. Claims have been made that some systems using diurnal storage in combination with combined heat and power (CHP) plants can achieve 25% annual SF, but higher values are said not to be possible without the use of seasonal storage [13]. However, higher design SF can be reached with a strategic storage placement and the appropriate choice of distribution system [14]. Unfortunately, there are only few studies on this and most studies focused on

optimisation includes long-term storage of some sort. One study ventures into the combination of long and short-term storage, but does not evaluate the use of short-term storages only, although the use of only a buffer tank shows a possible SF of around 23% [15]. Other studies on the Drake Landing solar community do treat the use of short-term distributed storages, but one [16] does this to show the benefits of using short-term storage in combination with long-term storage in terms of certain key performance indicators (KPI). Another study works on the premise of having a very high SF of 97%, which is unattainable by the use of only short-term storage, so the focus is more on lowering costs than enhancing the system performance [17]. More studies into efficient use of only short-term storage for SDH are therefore needed.

Extensive research efforts have investigated modular technical solutions for small SDH systems in newly built residential areas [18], looking at different ST integration typologies and variation in both storage size and placement, as well as collector field placement (e.g. decentral or central) – among many other aspects considered. Main findings resulted in identification of 2-pipe SDH systems with distributed (short-term) storages as:

- Having the lowest heat distribution losses (related to 2-pipe system).
- Low investment costs (related to 2-pipe system and smaller culvert due to distributed storage).
- Easily expandable due to the distributed nature of the storages.

The main disadvantage was supposedly the requirement of a detailed controller regime to operate the system, aside from a 5–10% lower solar yield (related to the solar system integration in the heating network).

The latest years have seen a resurgence in the research interest surrounding renewable supply alternatives for DH [19]. ST integration concepts have been investigated further in a number of projects, where [20] provides a review of the various integration techniques for ST, among others. A review has also been made of the operating experiences from 22 SDH plants with the ST connected to the primary (supply side) and potential improvements in new systems [21]. Further efforts have been made to map the most common SDH system typologies in Europe [22] and to evaluate the decentralised integration of ST with house substations from a techno-economic perspective [23]. The use of medium scaled storages (volume less than 1000 m³) in combination with diurnal storages was investigated by Bauer et al. [24], showing that small SDH systems can be a viable alternative to large scale solutions from both a technical and economical point of view. A recent study compared solar thermal systems of different sizes with either long-term, short-term or combinations of short- and long-term storage, also looking at the collector placement (decentral or central). It was found that a combination of decentralised long-term and short term-storage for SH and DHW, respectively, is preferential from a techno-economic perspective [15]. However, details of the employed distribution pipe characteristics are omitted and lumped SH and DHW heating are not investigated and neither are combinations of short-term storages or central preparation of DHW. Studies providing information on these aspects should therefore be provided.

Two-pipe distribution systems in block-heating systems have been found to generally show lower annual heat costs than corresponding four-pipe systems, especially for low heat-density networks. Furthermore, the costs of heat distribution losses are considered to be a small part of the overall heat cost and that the largest cost reduction potential is in the investment cost for heating system design and routes [25]. Moreover, it has been confirmed that two-pipe systems should also be used for low-energy housing areas, but use of a cross-linked polyethylene (PEX) pipes for house connections was emphasised [26]. In Dalla Rosa et al. [27], two-pipe systems using two single pipes have also been found to reduce investment costs with proper system configuration, possibly in combination with 3-pipe house connections, although this excluded the heating route (trench) cost. Two-pipe DH systems in combination with ST (i.e. SDH) has also been linked to low

environmental impacts, having second least energy (total energy use from construction and operation) use, only surpassed by four pipe PEX pipe systems [28]. Furthermore, a life cycle assessment (LCA) has shown that a two-pipe EPSPEX culvert probably had a lower environmental impact than an equivalent conventional steel culvert [29].

Today's DH systems typically employ polyurethane (PUR) foam insulated steel pipes to distribute heat, which is generally considered the industry standard. Several advantages of PEX pipes were discovered during the 1970's, when several trials were made using PEX-pipes for secondary distribution of heat in DH networks. Unfortunately, a range of negative experiences led to the technology being abandoned in favour of steel pipes. Fortunately, since then modern PEX-pipes have been developed which enables realisation of the potential technical and economic advantages of PEX-pipes [30]. The costs of steel pipes generally used to be much higher than those of polymer piping and the heat losses likewise. This was firstly reported in early studies on employment of plastic pipes in block heating systems [31], but also in later studies [32]. Utilizing inexpensive PEX pipes compensate for more expensive heating systems and utilizing a decentral storage enables use of lower design power of the boiler, which together enables a low overall system cost [25]. In recent years, the cost difference between PEX and steel pipes has reduced significantly [33], which means that their previously reported advantages need to be re-evaluated.

The GRUDIS piping concept was developed during the 1980s with the intention to offer a low-cost distribution alternative to residential areas where traditional steel pipe culverts would be too expensive due to low network heat demand densities, i.e. city outskirts and suburbs [30]. It uses PEX pipes in a form of district level domestic hot water circulation (DHWC) that results in a simpler and less expensive substation that has a heat exchanger for the space heating, but no heat exchanger for DHW, as it is drawn directly (see Fig. 1 in section 2.2.1). This also enables a lower distribution temperature in the network. According to the concept of 4th generation DH [6], low distribution temperatures and recirculation of water in plastic pipe distribution networks are desirable improvements to current generation DH systems [34]. This means that GRUDIS can be considered a 4th generation DH technology due to the fact that the technology was developed as an alternative to the 3rd generation DH system technology [35] and that the characteristics largely correspond to those considered desirable in future DH systems [36].

The Vallda Heberg SDH system used as basis for this study, was designed on the basis of a combination of engineering experience and research efforts into HVAC, energy technology and heat supply systems. Previous built systems showed up to 35% SF based on useful heat demand, which was set as a benchmark for the new system [11] that aimed to achieve a SF of 40%. As the housing area has a very low energy density, with low energy houses, the distribution losses are central to the overall function and efficiency of the system. This system has several features that try to address this issue: the GRUDIS piping concept is used in local secondary networks to the houses supplied by de-centralised substations; backup heat is provided by a central boiler plant via a primary network of conventional steel pipes; solar thermal and storage is decentralised in the substations but is also included in the boiler central.

There has been an attempt to map the potential cost reductions by strategic placement of short-term storage in DH systems [37,38], but none looking at alternative integration typologies for short-term storages in combination with central and distributed collectors. Despite several of the previously mentioned studies that treat the use of PEX pipes in DH systems [26,27,35], their employment is still rare and significant studies on alternative distribution systems like GRUDIS, with central DHW preparation in combination with SDH, are missing. The literature review shows that the features used in the Vallda Heberg

system can be of benefit, but that the novelty lies in the combination of them. Previous studies have shown how the system works, including a detailed technical description as well as a partial [39] system energy balance and a summary of the preliminary results on system performance [10]. More extensive work has also been done to describe the system in great detail, together with a complete energy balance for the whole system [40]. Furthermore, the IEA task 52 on solar heat in urban environments presented the system as one of the "best case" examples of SDH and focused on its success factors [9]. However, none of these or other studies have provided a systematic comparison of the benefits of the GRUDIS concept combined with solar and whether this is better applied in secondary networks or should be for the whole housing area. Thus, this study incorporates the essential features of the Vallda Heberg system, but simplifies the housing area and distribution system in order to make clearer the advantages and disadvantages of the combination of the main features.

Aim and scope

The main research questions to be answered by this paper are: does the GRUDIS distribution lead to lower distribution losses and better system efficiency in solar block heating systems than conventional distribution with steel pipes; and whether intermediate substations are of benefit or not?

A small solar DH system with novel heat distribution is used as a basis for the development of a simulation model with similar technical specifications. The heating needs of the low energy buildings, number of housing units, number of substations as well as size of solar collector and stores are similar to the Vallda Heberg system, but overall system typology is simplified. This hybrid system comprises conventional steel distribution pipes combined with central DHW preparation in intermediate substations and hot water circulation in a secondary network with plastic pipes. Two alternative system models without intermediate substations are made based on the hybrid model, but using different distribution concepts: one using conventional steel pipe distribution throughout; and one using plastic pipes with hot water circulation throughout. Simulations of the three distribution concepts are made with the aim of investigating the impact of changing the distribution system in terms of culvert pipes and location of storages in the network. A sensitivity analysis on the performance of the different system alternatives is made by variation of the linear heat density of the network, aiming to determine any potential range bound limitations of the results from the initial simulations. In all models, the same collector area and storage volume is used. Furthermore, a simple economic analysis is conducted to give some indications on the cost differences between different distribution options.

The novelty of this paper lies in the introduction of a novel distribution concept (GRUDIS) for district heating systems in which DHW is prepared centrally and distributed in a combined space heating and hot water circulation loop, from which DHW is drawn directly without preparation in a local external heat exchanger. This has not previously been done for solar district heating plants and has only been described to a very limited extent in previous literature about district heating. This concept provides a viable, alternative and proven system design for 4th generation district heating and extension of 3rd generation networks. Moreover, the paper describes the strategic use of distributed short-term storages to achieve solar fractions higher than what is normally considered feasible without long-term storage. This too, has no previous analogue in the literature of solar district heating. In combining the two previous points mentioned, the distribution concept holds the potential of a higher resource efficiency by savings in boiler fuel consumption,

compared to conventional distribution technology. This has previously been reported for district heating systems in Sweden, but has not been linked to being a way of making solar district heating more competitive. Furthermore, the work goes on to investigate how the novel distribution system can be utilized more comprehensively to further simplify system design, omitting the use of distributed storages with the advantage of lower system complexity, higher energetic efficiency due to lower heat losses and potentially lower costs than the original system from which it was derived. This proposed system design and the potential economic benefits presented also has no analogue in previous literature.

Methods

The method chapter firstly outlines the overall approach, before describing the specific methods in more detail.

Overall system

A real solar assisted DH system is used as basis for a model in TRNSYS 17 (v.17.02.0005) [41], including houses, substation, primary and secondary distribution system in addition to solar fields and a boiler central. This is labelled the “hybrid” system in this study and is used as a benchmark to other system models with other distribution systems. A hypothetical DH system is configured and technical specifications of the real system are used to determine the design heat load in different subsystems, while the distribution network is dimensioned according to best-practice guidelines and available standards. The design heat loss of the distribution network was calculated using manufacturer catalogue values for specific heat loss of various pipe materials and dimensions and the models losses were calibrated to this design heat loss.

In order to simplify the system model, and to make the study more general and less case specific, the following simplifications have been used:

- A multiplication factor has been used to scale common “blocks” such as houses and substations, to give the heat load of the whole system.
- The distribution network has been modelled by using pipe elements to represent the pipes of same nominal diameter and pipe type have been lumped together to give the same heat losses as the design heat loss of the network.

For information about the simulation model, please visit section 3 or the data repository [42] for a more detailed description.

A sensitivity analysis on LD is made as well as a simple economic analysis using distribution pipe costs and estimation of costs for substations in the various distribution concepts, but excluding installation

Table 1

Concept overview – summary of the main components of the three distribution concepts studied. Abbreviations: HX = heat exchanger(s).

Component	GRUDIS Fig. 1	Conventional DH Fig. 2	Hybrid Fig. 3
Boiler central	Storage for all collectors, DHW HX	Storage for all collectors	Storage for centralised collectors
Intermediate substation	N/A	N/A	Storage for distributed collectors, DHW HX
House substation	SH only	SH + DHW HX	SH only
Network pipes & operating temperatures	Primary: PEX 60/50 °C	Primary: Steel 75/45 °C	Primary: Steel 75/50 °C Secondary: PEX 60/50 °C
Collectors	Centralized: ETC Distributed: FPC	Centralised: ETC Distributed: FPC	Centralised: ETC Distributed: FPC

costs. The costs are evaluated with respect to energetic performance and compared among the distribution systems investigated.

Distribution systems

Three different distribution concepts have been investigated in this study by configuration of three DH systems supplying the same load type and size as well as location. Table 1 shows the configuration of different DH subsystems for the distribution concepts presented, along with a reference to the figure that shows each subsystem schematic in parenthesis. The energy system supply parameters are the same for all systems, such as the installed solar collector area, solar buffer storage volume and boiler capacity. The distribution network lengths are also the same, although the pipe type employed varies.

The hybrid system can be said to represent a combination of 3rd and 4th generation DH technology, presenting innovative solutions to the mismatch between the high temperatures in conventional DH systems and the lower temperatures required for increased performance of the solar thermal collectors. The GRUDIS system may represent a suggestion to an alternative system configuration that better matches the temperature requirement of the solar thermal collectors and a potential example of 4th generation DH technology. The conventional DH system is used quantify the energetic improvement of the alternative system designs compared with a more traditional system design for this particular housing area and typology. The three systems are described more closely together with a schematic in subsection 2.2.1, 2.2.2 and 2.2.3 while detailed descriptions of the subsystems are provided in the data repository [42].

Grudis

Fig. 1 shows the GRUDIS concept with the boiler central to the right and central DHW preparation, which is partially supplied by roof-mounted evacuated tube collectors (ETC) and ground mounted flat-plate collectors (FPC), as well as a passive single-family house to the left. Heat is distributed by circulating hot water in PEX pipes using a so-called GRUDIS 2-pipe system [30], similar to a DHW circulation system. In the house substations, DHW is tapped directly from the circulation loop and simultaneously make up cold water (CW) is supplied and heated in the boiler central (BC), while space heat is supplied via floor heating in a bathroom and ventilation air heat exchanger. In the BC, heat is supplied from building integrated ETCs as well as FPC arrays distributed in the system, while a wood-pellet boiler provides auxiliary heat for the hot water circulation to reach the target supply temperature of the building stock, when the contribution from the solar collectors is insufficient.

One significant consequence of this configuration of distribution and heat supply is that solar heat harvested in the system must be transported back to the BC for storage, which means that the solar buffer storage volume must be allocated to the BC. This requires making the BC a bit larger and the central storage location may lead to some additional solar culvert heat losses, lowering the solar energy system performance.

Conventional district heating

Fig. 2 shows a schematic illustration of the conventional DH concept with the boiler central to the right, partially supplied by building integrated ETCs and ground FPCs and a passive single-family house to the left with local DHW preparation. In the conventional DH system, the DHW is prepared locally in the house substation, making a local DHW heat exchanger necessary in each house.

Although the solar storage is located in the BC in this concept, there is no preparation of DHW and so the efficiency of the solar collectors should be affected negatively by higher operating temperatures, in addition to the higher heat losses associated with central storage as mentioned in Section 2.2.1.

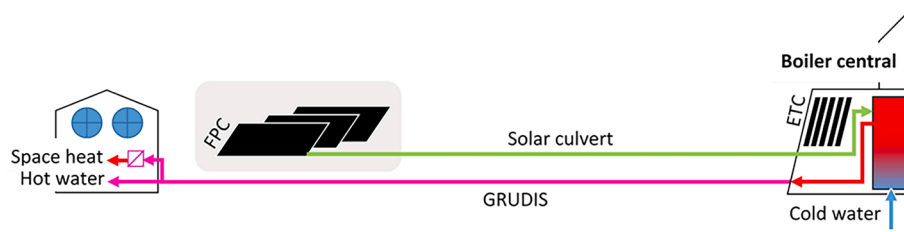

Fig. 1. GRUDIS distribution - Simple schematic of GRUDIS distribution system with boiler central (BC) and single-family house. Ground mounted flat-plate collectors (FPC) and evacuated tube collectors (ETC) on the BC.

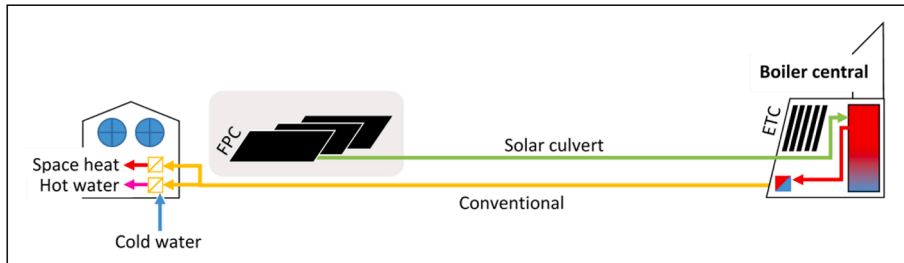

Fig. 2. Conventional distribution - Simple schematic of conventional DH distribution system with boiler central (BC) and single-family house. Ground mounted flat-plate collectors (FPC) and evacuated tube collectors (ETC) on the BC.

Hybrid distribution concept

Fig. 3 shows a schematic illustration of the hybrid distribution system, with the boiler central to the right, intermediate substation in the middle and a passive single-family house to the left. The hybrid system comprises a combination of the GRUDIS (see Fig. 1) and the conventional concept (see Fig. 2). It consists of one BC and four intermediate substations (SS). Solar buffer storage tanks are located in the BC and in each intermediate substation. There are FPCs located on the roof of the substations and in ground mounted arrays close to the substations, which supplies heat to the substations through the solar heat culvert (green lines in Fig. 3). Heat is distributed from the intermediate substations to the buildings in a GRUDIS system, by circulating hot water in PEX pipes and drawing DHW directly from the pipes. However, in the hybrid system, this distribution is only part of the system and is employed in a secondary network. The BC supplies the substations with heat from a wood-pellet boiler and building integrated ETCs, through a conventional steel pipe primary network. The primary network is connected to a heat exchanger located in the intermediate substation, providing auxiliary heating for the hot water circulation to reach the

target supply temperature of the building stock, when the contribution from the solar collectors is insufficient.

The goal of this configuration is a simple heating system of low investment cost, although one disadvantage is large heat losses in the distribution pipes and sub-stations, which increases running costs.

Heating network configuration

In this study, three models are made of a hypothetical DH system, supplying 100 single-family houses distributed throughout the system in four areas (A1 – A4), each area consisting of 25 houses. Each house has 140 m² of heated floor area and the simulated heat demand (SH + DHW) is only 38 kWh/m²•a. Schematics of the DH network are presented in Fig. 4 a) the GRUDIS system and b) the hybrid system. Only housing area A1 is denoted in the figure. In the figure, one house corresponds to five houses. The conventional heating system is not shown, as it the outlay is identical to the GRUDIS system (Fig. 4 a)). It can be seen that the main difference between the networks is the location of the solar collectors, as well as presence of intermediate substations in the hybrid system acting as hydraulic separation between the conventional primary network and

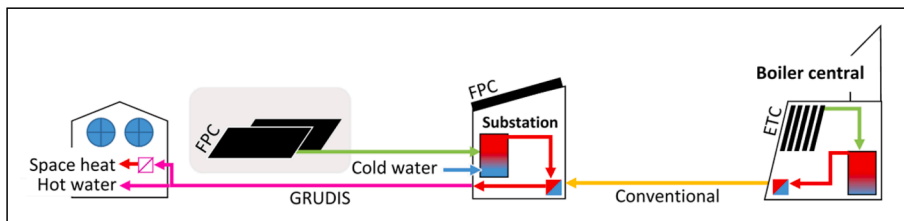

Fig. 3. Hybrid distribution - Simple schematic of the hybrid heat distribution concept with boiler central (BC), intermediate substation and single-family house. Roof and ground mounted flat plate collectors (FPC), evacuated tube collectors (ETC) on BC.

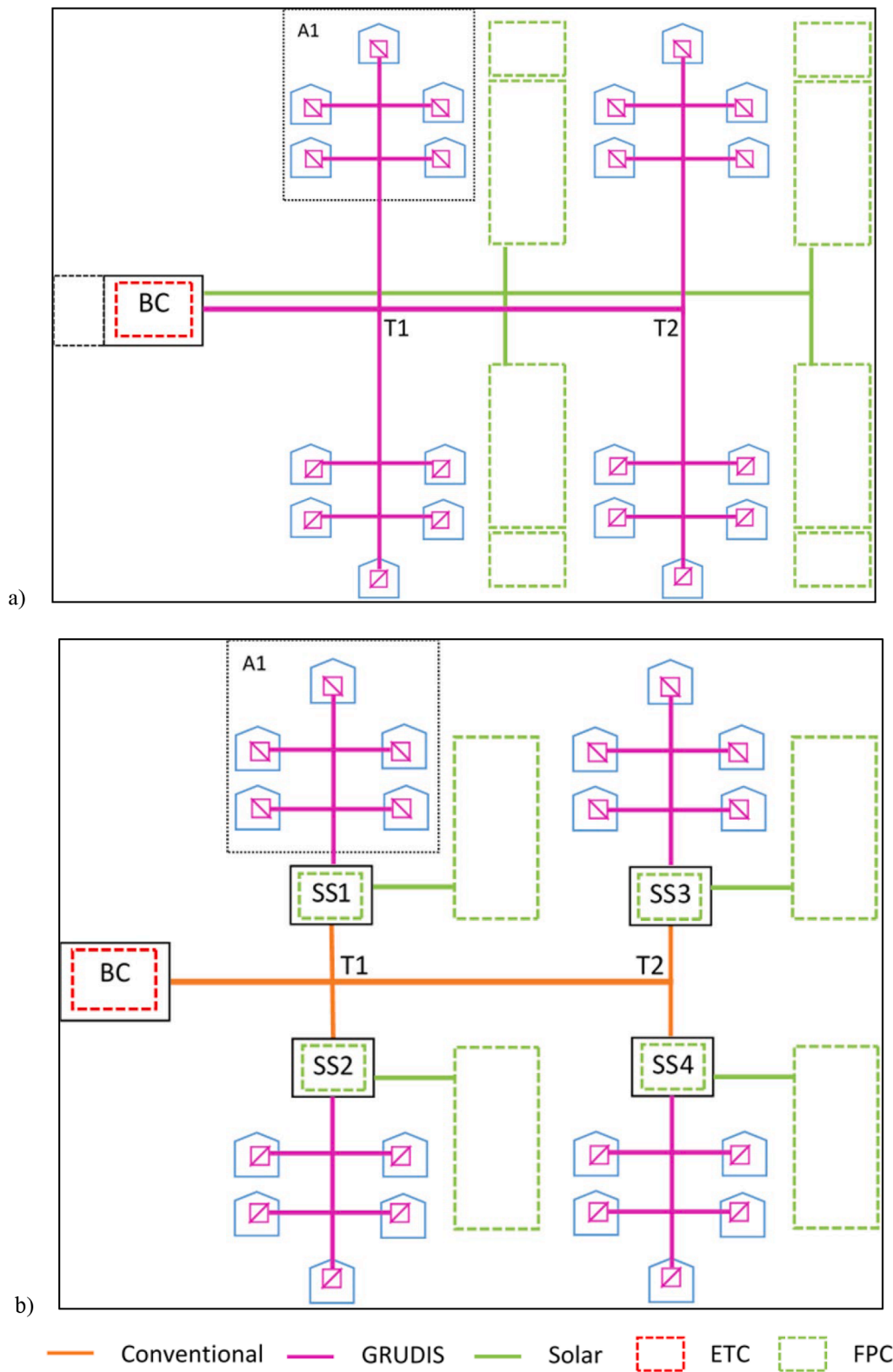

Fig. 4. Network configuration – schematics of a) GRUDIS network and b) hybrid network. Evacuated tube collectors (ETC) are located on the boiler central (BC) and flat plate collectors (FPC) are located on either intermediate substation (SS) and/or ground.

GRUDIS secondary network. The solar collectors in the hybrid model are distributed partly on the intermediate substations, while in the GRUDIS system they are allocated on the ground only.

Network characteristics

Table 2 shows an overview of the main network characteristics for the three distribution systems studied. The alternative distribution concepts investigated in this study are extensions of the primary and secondary network in the hybrid system, respectively (see Fig. 4).

Table 2

Distribution network characteristics – Overview of the pipe type and application area, as well as design operating temperatures for the three distribution systems used in this study.

	GRUDIS	Conventional DH	Hybrid
Primary network	PEX main/branch/service pipes Temperature supply/return 60/50 °C	Steel main/branch/service pipes Temperature supply/return 75/45 °C	Steel main/branch pipes Temperature supply/return 75/50 °C
Secondary network	N/A	N/A	PEX branch/service pipes Temperature supply/return 60/50 °C
Solar culverts	Steel main/branch pipe(s) Copper header/connection pipes	Steel main/branch pipe(s) Copper header/connection pipes	Steel branch pipes Copper header/connection pipes

Because the conventional DH and GRUDIS distribution have no intermediate substations, they only have primary networks and solar culverts. In lack of a commonly adopted terminology to describe hydraulic pipe networks, this paper uses a *specific terminology* to differentiate between pipe types. The distribution network consists of “main” pipes that are connected in series to supply the (parallel) “branches” of the system. Generally, branch pipes are considered to supply any load larger than 1 house, whereas individual houses are supplied by “service” pipes.

In the hybrid system, the branch pipes supply the intermediate substations on the primary side and the housing area on the secondary side. In the conventional DH and GRUDIS concept, the branch pipes supply the housing area directly from the main pipe. The FPCs are connected with copper header and connection pipes and twin steel pipes to the substation (hybrid system) or boiler central (GRUDIS and conventional systems).

The distribution networks have been dimensioned according to the maximum (peak) load in the system, which has been calculated by summing up total design SH load with the aggregated DHW load in the various parts of the network. The peak flow rates in the network have been used together with flow velocity limits to calculate pipe sizes based on fluid dynamics theory. For the solar thermal system, pipes are sized using the same fluid dynamics theory and flow rates that have been calculated from values of specific flow rate per unit collector area and array size. The operating temperatures of the network are the same as those in the Vallda Heberg system [43], on which the hybrid system is based.

A description of the full sizing methodology and schematics of the modelled distribution networks can be found in an appendix supplied in the data repository [42].

Table 3

Heat supply – Overview of the heat supply configuration for the three distribution concepts investigated in this study. BC = boiler central, SS = Substation, GM = ground mounted.

Parameters	GRUDIS	Conventional	Hybrid
Boiler	300 kW		
ETC (tilt/azimuth)	108 m ² (70°/0°)		
FPC (tilt/azimuth)	619 m ² (GM) (30°/20°)	619 m ² (GM) (30°/20°)	177 m ² (SS) + 442 m ² (GM) 19°/25° (SS), 30°/20° (GM)
Storage tank	15 m ³ (BC) + 60 m ³ (BC)	15 m ³ (BC) + 60 m ³ (BC)	15 m ³ (BC) + 60 m ³ (SS)

Heat supply

Table 3 shows an overview of the heat supply configuration for the three distribution concepts investigated in this study. The DH system heat supply is the same for all distribution concepts, with a 300 kW wood-pellet boiler as main heat supply and 108 m² evacuated tube collectors (ETC) connected to a 15 m² storage in the boiler central (BC). Only the location of flat-plate collector (FPC) arrays and corresponding solar thermal stores varies.

In the hybrid system - each intermediate substation features a 15 m² storage connected to roughly 155 m² of FPC, divided into about 44 m² mounted on the substation roof and about 111 m² ground-mounted (GM) near the substation. In the GRUDIS and conventional DH system, there is roughly 155 m² of GM collectors in connection to each housing area. These larger GM collector arrays are essentially extensions of the GM arrays in the hybrid system and the heat from these is stored in a 60 m² storage in the BC. All storage volumes consists of smaller, off-the-shelf, 5 m³ accumulator tanks. Therefore, each in the hybrid system, each intermediate substation and the BC contains three storage tanks.

Network costs

In order to get an indication of the cost implications of using different distribution concepts, a simple cost analysis was made comparing costs estimates of using conventional DH or GRUDIS distribution, instead of hybrid distribution. Included components were heating network pipes (main, branch and service pipes), solar culvert pipes (excluding copper pipes used for headers and connections), as well as cost estimates of intermediate and house substations. However, the costs of a large boiler central in the GRUDIS and conventional DH system are excluded, as a more detailed analysis is necessary to find these and this is considered out of the scope of this study. All cost values have been converted from SEK to EUR with an exchange rate of 10 SEK per EUR.

The pipe costs used in the analysis were supplied by manufacturers Powerpipe (Sofia Borg, personal communication) [43] and Elgocell (Magnus Klingheim, personal communication) [44] for twin-steel pipes (Table 4) and EPSPEX culvert (Table 5), respectively. The cost of connections, welding and VAT is not included.

Costs for the pipe trenches are assumed to be 160 EUR/m and that 30% of this cost is added for double trenches in the case of parallel pipes. Trench costs, as well as price estimates for the intermediate and house SS in the Vallda Heberg system [40], which is the basis for the hybrid system, was provided by HVAC consulting firm Andersson & Hultmark [45] (P.A. Jessen, Personal communication). The price estimate for a villa heat exchanger was taken from price lists in software Wikells sektionsdata (Swedish) [46]. Table 6 shows 2019 price estimates for an intermediate substation in the hybrid system and house substation (SS) in hybrid/GRUDIS system and conventional DH system.

The price of an intermediate substation includes only the building and not internal components such as storage and piping. The total storage volume and associated piping in the DH system is similar for both intermediate substations (hybrid) and large boiler centrals (GRUDIS and conventional), so the costs for this is assumed to be same for all distribution concepts.

Sensitivity analysis

The initial LD of the DH system modelled in this study was 0.2 MWh/m²•a, which is considered representative of a sparse DH network and has been considered the lowest economically viable LD for conventional DH

Table 4

Prices (ex. VAT) for series 1 pre-insulated twin-steel pipes from manufacturer Powerpipe [43].

Pipe dimension	DN80	DN65	DN50	DN40	DN32	DN25	DN20
Price [EUR/m]	70.4	62.9	53.5	39.2	38.2	34.3	34.3

Table 5
Prices (ex. VAT) for EPSPLEX culvert from manufacturer Elgocell [44].

Pipe dimension	DN110	DN90	DN63	DN50	DN40	DN32	DN25
Price [EUR/m]	128.2	100.6	62.6	50.0	42.1	31.7	29.5

Table 6

Price estimates (ex. VAT) for intermediate substation in hybrid system and house substation (SS) in hybrid/GRUDIS and conventional DH system. The price of an intermediate substation is for the building only, as it is assumed that cost for the internal components are the same for both intermediate substations and large boiler centrals.

Component	Intermediate SS	House SS – Hybrid/GRUDIS	House SS – Conv.
Price [k EUR]	60	2	6

[47]. The low LD in the modelled system is due both to the housing area consisting of single-family houses and the fact that these houses have a low energy demand. The spatial limitations of the housing area does not allow for a higher LD without changing the building type from single-family houses to multi-family houses. Therefore, it is natural that a sensitivity analysis focuses on the differences in performance of the different distribution concepts when going from a sparse (e.g. suburban) to a very sparse (e.g. rural) DH network. Additionally, an extremely low value should be included as well, as such a sensitivity analysis can provide useful information on the lower limits of LD for the distribution concepts studied.

The sensitivity analysis is performed by variation of LD in the distribution network. The LD is varied by changing the length of the pipe segments from 1.0 to 0.5 and 0.25 times that of the reference system, corresponding to 1.0, 0.5 and 0.25 times the original LD, respectively. The value 1LD, 0.5LD and 0.25 LD therefore corresponds to 0.2 MWh/m² (sparse DH), 0.1 MWh/m² (very sparse DH) and 0.05 MWh/m² (extremely sparse DH), respectively. The solar culvert length is maintained the same regardless of the value of LD, as the location of the solar installations can remain the same for a lower density of the built environment. This should also improve the comparability of the results.

Key performance indicators (KPI)

The KPIs employed are used to measure the system performance is various ways:

System net utilised solar energy (NUSE_{sys}):

$$NUSE_{sys} = \frac{Q_{FPC} + Q_{ETC} - Q_{distloss}}{Q_{housetot}} = 1 - \frac{Q_{boiler}}{Q_{housetot}} \quad (1)$$

Performance ratio (PR):

$$PR = \frac{Q_{housetot}}{Q_{boiler} + Q_{ETC} + Q_{FPC}} \quad (2)$$

Solar fraction (SF):

$$SF = \frac{Q_{ETC} + Q_{FPC}}{Q_{boiler} + Q_{ETC} + Q_{FPC}} \quad (3)$$

Where the key figures used in the equations are as follows: $Q_{house\ tot}$, Total house (SH + DHW) energy demand of the houses in the DH network. $Q_{BC\ loss}$, Losses from storage for ETC solar and boiler plus internal connection pipes. $Q_{solar\ st.\ loss}$, Losses from FPC solar storage plus internal connection pipes. Q_{boiler} , Energy supplied from boiler to flow stream, excluding losses. $Q_{dist\ loss}$, Losses from ground buried pipes. Q_{ETC} , Stored solar energy from evacuated tube collectors. Q_{FPC} , Stored solar energy from flat plate collectors.

All variables have units of energy [J or kWh]. All KPIs are

dimensionless parameters.

The system net utilized solar energy (NUSE_{sys}) is a measure of how much solar energy contributes to the net heating demand, after losses have been subtracted. Note that the NUSE_{sys} defined in eq. (1) is different from the NUSE conventionally used for solar combi-systems [48] which is based on the supply-side perspective, in that it takes into account the distribution losses of the system and the house energy demand (load-side perspective).

The performance ratio (PR) measures how well the system performs, by presenting the relative share of net heating demand to total heat supply. It is mostly used to indicate the loss fraction for inter-comparison between energy systems. Its reciprocal indicates the relative amount of energy input the system needs to supply the demand.

The solar fraction measures the relative share of the total energy supply made out by solar energy. In contrast to NUSE_{sys}, it includes losses and therefore gives no information about the efficiency in utilisation of solar energy. Energy systems of poor PR could have a high SF, but would have a low or negative value of NUSE.

TRNSYS modelling approach

This section outlines the modelling approach and describes the major characteristics of the different parts of the system. However, system schematics and detailed descriptions of the system models are not provided here, but can be found in the data repository [42]. Although the system model is a theoretical one, all parameters used in the system component models (see Table 7) such as boiler, pipes, solar collectors and storage tanks included in this system model are based on specifications found in datasheets on real components.

Overall modelling approach

All system models developed in this study build on the same overall approach (see Fig. 5), although only the hybrid system approach is shown here. The primary reason for using this simplified approach is due to limitations on the maximum number of component outputs in TRNSYS and long simulation times when exceeding these. Due to the symmetric nature of this theoretical DH network, this modelling approach is assumed to have minor influence on the results, as the primary focus of this study is total energy use and an inter-comparison between system variants.

The hybrid system has been modelled by the use of three subsystem models in TRNSYS:

- 1) Building and house substation model (SH load multiplied by 25 to represent one housing area).

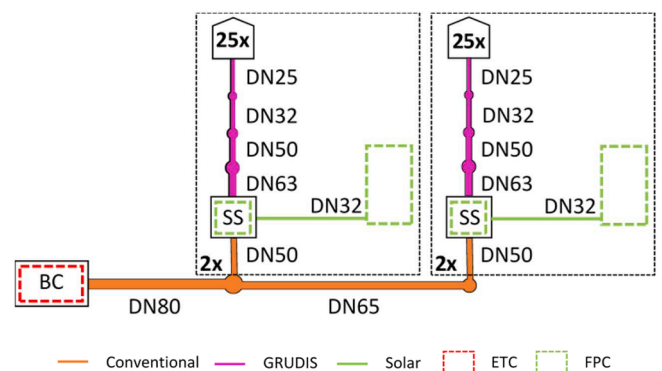

Fig. 5. Overall modelling approach – Schematic showing the hybrid system's model structure including subsystem models and applied twin pipe sizes. Note that copper pipes in solar circuit are not shown for simplicity. Multiplication factors (2x and 25x) are indicated where these are used to scale up subsystem models.

- 2) Intermediate substation model (multiplied by 2 to represent sub-system load) with ST system.
- 3) Boiler central model.

As is shown in Fig. 5, the overall system was modelled using the BC model supplying two main pipes (DN80 and DN 65) in series, in turn supplying two branch pipes (DN50) and two intermediate substation models - each supplying one building and house substation model. The pipe network in each housing area is modelled by using one pipe element for each pipe size used and giving each element the total length of pipes of that size. Thus, parallel pipes (e.g. DN 25 service pipes) are modelled as being connected in series, with the load (building and house substation model) connected at the end. To achieve the total load on the BC, each building and house substation model is scaled (multiplied) by a factor 25 and each intermediate substation model was scaled (multiplied) by a factor 2 to give the total load of the system. This load was then used to calculate the required flow rates in the primary network pipe elements given the simulated supply- and return temperatures, thus simulating a realistic load in the primary network.

Common components for all system models

Table 7 gives an overview of the main TRNSYS components employed and parameter settings:

The solar collector models used are based on collectors in the Vallda Heberg DH system, on which this study is based. The efficiency parameters (Table 8) of the modelled FPC [52] and the modelled ETC [53], were taken from the collector datasheets (available from the data repository [42]).

Table 8 shows the efficiency parameters used as input to the solar collector models in TRNSYS:

Each storage volume in this hypothetical system consists of smaller off-the-shelf 5 m³ tanks. However, in the simulations, the total storage volume is modelled as one large tank, using the same diameter for each tank and adjusting the height in order to reach the same surface-area-to-volume ratio as off-the-shelf 5 m³ accumulator tanks. This was done for reasons of simplicity, in order to reduce the number of model connections according to limitations in TRNSYS and corresponding workload/simulation time if to exceed these. The tank model is divided into three sections of relative heights 0.1, 0.8 and 0.1 for higher, middle and lower part of the tank, respectively. An overall U-value of 1.37 W/m² K [54] is used to calculate the UA-value of the whole storage and each respective section for input into the model. This U-value was measured in a laboratory test comparing TRNSYS simulations against real performance for a similar storage tank. Heat losses through top and bottom were *not* modelled separately.

Table 7

Main TRNSYS components and parameter settings [51]. Non-standard components are referenced individually, TESS components are described in [49].

Name	Component type	Main parameters	Descriptions
Weather data	Type 15	Kungsbacka, Sweden (57.5°N, 12.0°E), TMY	Data from Meteorom 7 (v.7.3.4)
Boiler	Type 659 (TESS) [49]	300 kW	Wood-pellet boiler
ETC	Type 538 (TESS)	108 m ²	Fluid: water. Tilt 70, azimuth 0
FPC	Type 832v501	620 m ² ; allocation varies according to concept (see Table 3)	Fluid: 40% propylene glycol/water. Int . substation: Tilt 19, azimuth 25 Ground mounted array: Tilt 30, azimuth 20 Diurnal storage; volume depends on system
Tank(s)	Type 340 [50]	15 m ³ /60 m ³	Variable control signal, power consumption and dissipation to fluid stream ignored.
Pump(s)	Type 3	Max flow rate; Varied parameter values	Internal gains: 400 W passive + 70% of electricity consumption [40].
House	Type 56	Base area 70 m ² , two zones, internal gains.	Same effectiveness for both sensible and latent.
Heat recovery	Type 667 (TESS)	Rated power: 186.4 W, Effectiveness: 0.8.	
Water-air HEX	Type 670 (TESS)	Fluid: Propylene glycol. Effectiveness: 0.8.	Set point 19.5 °C for controller of flow to component.
Twin-pipe(s)	Type 951 (TESS)	Varied parameters for each pipe size and type.	Distribution network pipe for conventional and GRUDIS
Single pipe(s)	Type 709 (TESS)	Varied parameters according to pipe size	Connection pipes for solar collectors and internal supply pipes in BC and intermediate substations.
DHW load(s)	Type 9	Flow rate	Generated DHW profiles, 1 profile per 50 houses.

Table 8

Efficiency parameters – Input parameters used for the solar collectors models in TRNSYS.

	η	a1	a2	C _{eff}	b0	b1
FPC	0.824	3.920	0.0071	5.37	0.18	0
ETC	0.644	0.749	0.005	9.18	NA	NA

Table 9

Storage tank parameters – Height and UA-value (TRNSYS native unit) for an off-the-shelf storage tank and the two other storage volumes modelled in this study.

Volume [m ³]	Height [m]	UA [W/K]
5	2.50	22.7
15	9.07	68.0
60	38.67	271.8

Table 9 shows the height and UA-value for an off-the-shelf 5 m³ storage tank and the two other storage volumes modelled in this study with TRNSYS:

For full overview of the used component types and applied input parameters of these, DCK files are provided for each system model in the data repository [42].

Solar energy system model

In order to understand the solar energy system model, Fig. 4b should be compared with Fig. 5 and the parameters in Table 3. The solar energy system is modelled by using two collector models for each of the two housing areas simulated, e.g. as consisting of two arrays for each housing area. The only difference between distribution concepts is that in the hybrid model (see Fig. 5), the FPC area is split between 44 m² SS arrays and 111 m² GM arrays for one housing area and that these arrays have slightly different orientations (see Table 3). In the GRUDIS and conventional system, the GM arrays are extended to include the total FPC collector area (155 m²) for one housing area. The differences in solar energy system layout leads to some differences in pipe lengths for the solar culvert, header and connection pipes. The conventional and GRUDIS system uses 130 m more steel pipe for mains and branch pipes and 220 m more copper pipes for header and connection pipes, than in the hybrid system. This naturally increases solar culvert heat losses somewhat. For more detailed description of the solar culvert, see data repository [42].

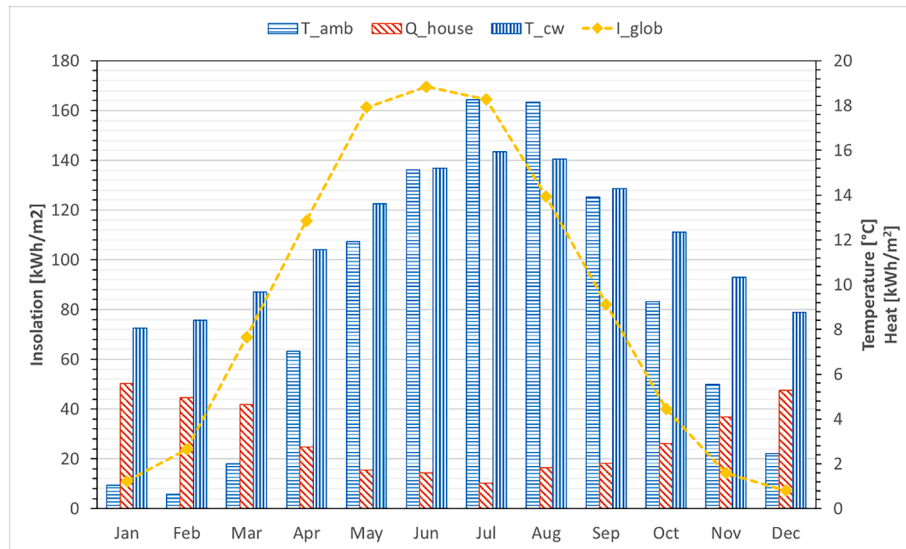

Fig. 6. Climate data – graph showing monthly global insolation (I_{glob}), ambient temperature (T_{amb}) and inlet cold water supply temperature (T_{cw}), along with monthly specific heat demand (SH + DHW) for a single-family house (Q_{house}), in Kungsbacka, Sweden.

Climate data and heat demand

Weather data has been generated using Meteonorm 7 (v.7.3.4) for Kungsbacka, Västra Götalands län, Sweden (57.5°N, 12.0°E). The data was exported as a.tml file and used as input for a data reader.

Fig. 6 shows monthly global insolation, ambient temperature and inlet cold water supply temperature, along with average specific heat demand for a single-family house, in Kungsbacka, Sweden.

The annual global horizontal insolation is 984 kWh/m². The simulated annual specific heat-demand (SH + DHW) is ~38.5 kWh/m², with values ranging from 5.6 kWh/m² (January) to 1.1 kWh/m² (July). The annual specific heat demand in the houses upon which this building model is based has been investigated in [40] and the mean value was 52 kWh/m², but ranged from 40 kWh/m² to 75 kWh/m² including electricity for appliances (4–8 kWh/m²). This means that the simulated energy demand is within the range of measured energy demand in the system. The simulated total annual heat demand for the entire residential area is about 542 MWh.

Domestic hot water profiles

The DHW profiles for the DH system were generated with DHWcalc (v.2.02), using a 3-minute random distribution [55]. The profile base is the statistical profile of a multifamily building using 4 tap categories (this is a function in the program) and a monthly step function for the seasonal variations - the maximum water consumption occurring in December (amplitude 24%). Weekend-day consumption was set to 130% (default) and each household is assumed to have 14 days of holiday during the month of July (general industrial holiday period).

Table 10 shows the input values for the 4 tap categories used in generation of the DHW profile used in simulations:

The relative share of the various taps are based on statistics on the distribution of water consumption in Swedish households [56]. The

Table 10

Input data – Overview of input values used with DHWcalc for generating a DHW consumption profile to use as input in the three simulation models developed in this study.

	Kitchen	Washbasin	Shower	Bath
Share of total [%]	40	20	30	10
Draw-off rate [L/s]	0.2	0.1	0.2	0.4
Draw-off duration [min]	6	3	12	9

draw-off flow rates listed were found using SS-EN 806-3:2006 [57] by using technical drawings of a passive house in the Vallda Heberg system [40] to identify types of tap categories and number of draw-off points.

The Swedish National Board of Housing, Building and Planning recommends using a value of 16 m³ per person and year (44 L/day), with an assumed 5% reduction due to resource efficient taps [58]. Therefore, the daily DHW consumption was calculated by assuming resource efficient taps, giving a specific consumption of 42 L per person and day [56]. With an average of three persons in each household, then for the entire DH system, this entails a consumption of 12,600 L/day.

Due to the symmetry of the DH system, the DHW load seen from the BC would coincide with the consumption of 50 houses at each of the T-junctions. Therefore, for the overall modelling approach presented in Fig. 5, it was decided to create two DHW profiles - each for 50 houses. The daily consumption of such a subsystem would be 6300 L and in order to give the two profiles different statistical distributions of draw-off volumes a “series” function was used, where the maximum daily flow rate was chosen to be 6250 L/day for one and 6350 L/day for the other. For information about integration of the DHW profile see the description of respective system concept.

The CW supply is modelled as coming from a nearby lake. The temperature of the inlet water thus is expected to follow an annual temperature curve corresponding to a sinus function, with an average temperature of 12 °C and an amplitude of 4 °C (January being the coldest).

Building and space-heating model

The houses are modelled using a two-zone building model based on drawings of a real house. Windows and shading are accounted for, together with internal gains from electricity use in equipment/appliances and passive gains from occupants. The gains are scheduled according to presumed occupancy time. The inputs to the building model are supplied in building information files in the data repository [42].

A mechanical ventilation system with auxiliary water–air heat exchanger and heat recovery heats one of the zones representing most of the house, the other zone (for the bathroom) uses floor heating. The supply flow first runs through the ventilation and air heating system and the floor heating loop is connected to its return. Because the circulation flow rate through the house heating system is fixed/constant, this results in passive floor heating, whereas the air heating is actively controlled by a room temperature sensor on the load side. The air-heating circuit is

supplied with heat from the distribution culvert (secondary network in the hybrid concept) by a fluid–fluid heat exchanger. More details on the house heating system and the model are found in [10] and [59] – schematics are found in the data repository [42].

Distribution pipe model

Distribution pipes were modelled using a buried horizontal twin-pipe (Type 951, TESS). For twin steel pipes, the casing thermal resistance was taken into account by replacing gap thermal conductivity (parameter 10) by that of the casing material (HDPE80) and the gap thickness (parameter 11) by that of the casing. For PEX pipes, the EPS insulation is also the casing and so no gap material is modelled (gap thickness null).

The EPS insulation of the PEX pipes has a square/rectangular cross-section in reality, while the twin-pipe model employed only takes cylindrical dimensions as input. This made it necessary to use the cross-sectional area of the EPS casing to calculate the equivalent casing diameter assuming a concentric circular insulation layer. This cross-sectional area was calculated based on dimensions for the culvert and a schematic drawing of the EPSPEX culvert cross section, found in the product catalogue of the pipe manufacturer. Furthermore, the spacing between supply and return pipe was found in the catalogue to be equal to the outer diameter of one pipe, meaning centre-to-centre spacing is equal to the outer diameter of two pipes - so this was assumed for all pipe sizes modelled. The pipe heat losses were calibrated against catalogue data on specific heat loss to make sure that these modelling inconsistencies have little impact. For detailed information about the culvert dimensions used, see the product catalogue [60] or the data repository [42].

Solar connection pipes (copper) are modelled using insulated single pipe ducts (Type 709, TESS).

Calibration of pipe losses

Pipe heat losses were calibrated against catalogue values for specific heat losses from pipe manufacturers Powerpipe (2018) [61], Elgocell (2017) [60] and Logstor (2018) [62] for steel-, PEX- and copper (Cuflex) pipes, respectively. These catalogue values were calculated by FEM analysis using calculation rules set out in SS-EN 13941:2009, assuming specific values for boundary conditions such as operating temperatures, ground temperature, trench depth and heat transfer coefficient for ground, pipe and insulation.

Table 11 lists the boundary conditions used when simulating specific heat loss for different pipe types in TRNSYS:

The heat transfer coefficient values for steel pipe wall and casing were taken from the catalogue of discontinuous double pipes from manufacturer Isoplus [63], as these were not available from Powerpipe.

Table 11

Boundary conditions – Input values of heat transfer coefficient and temperatures used for simulation of specific heat loss of different pipe types in TRNSYS. Pipe walls are assumed to maintain network operating temperatures (supply-return), due to the low thermal resistance of these.

Legend: Steel/Copper/ PEX	Pipe	Casing	Ground	Insulation
Heat transfer coefficient [W/m K]	55.2/365.0/ 0.4	0.4/ 0.4/-	1.5/1.6/ 1.0	0.026/0.022/ 0.034
Temperature [°C]	85–55/ 85–45/70–40	-/-/ -	5/10/6	50/50/80

Table 12

List of correction factors used to adjust insulation heat transfer coefficient for a range of twin-steel pipe sizes used in this study.

DN	20	25	32	50	65	80
Correction factor	a	b	c	d	e	f
	0.9710	1.1390	1.0810	1.0820	1.1675	1.1955
Calibrated heat transfer coefficient [W/m K]	0.0252	0.0296	0.0281	0.0281	0.0304	0.0311

The heat transfer coefficient value of PEX pipes was rounded to one decimal place. The trench depth was 0.6 m for Steel and PEX, 0.8 m for copper. Both steel- and copper pipes are insulated with PUR¹, whereas PEX pipes are encased in EPS.

To make sure that the pipe heat losses were modelled correctly when subjected to the boundary conditions of this study, the operation of a range of pipe sizes were simulated iteratively in TRNSYS under the same boundary conditions as specified in the pipe catalogue by respective manufacturers, for each pipe type. For each iteration, the insulation heat transfer coefficient was adjusted individually (see Table 12) for each pipe size until the catalogue value for specific heat loss was achieved.

Table 12 shows the correction factors used to adjust the PUR insulation heat transfer coefficient (see Table 11), as well as the adjusted values of the coefficient, for the range of steel pipe sizes used in this study. The correction factors for copper and PEX can be found in the TRNSYS input files in the data repository [42].

Results

The results are divided into an analysis of the energy balance (EB) for the simulated DH systems in order to identify the most energy efficient, followed by a sensitivity analysis where the changes in EB for each DH system is normalised the EB of the hybrid system. Lastly, a simple cost analysis is presented for the three systems studied.

Simulations and energy balance

Fig. 7 shows the simulated annual energy balance for the hypothetical DH system modelled in this study for three different choices of distribution concept, using KPIs listed in section 2.6. The concepts are listed in descending order of energy supply/demand.

Using only 835 MWh/3006 GJ of supplied heat to satisfy the annual demand of 543 MWh/1955 GJ, the GRUDIS system is most energy efficient with a performance ratio (PR) of about 66%. Compared to the hybrid system, using the GRUDIS distribution decreases boiler energy by about 31 MWh/110 GJ (5%), while solar yield and SF (32% for GRUDIS and 31% for Hybrid) differs by merely one percent for both concepts. The hybrid system uses 868 MWh/3125 GJ to supply the demand, which gives it a PR of about 61%, meaning it is slightly less resource effective. In the Conventional DH distribution system, boiler energy is increased by about 110 MWh/395 GJ (18%) relative to the hybrid system, which may be explained by a combination of about 57 MWh/206 GJ (17%) higher heat losses and 44 MWh/160 GJ (17%) lower solar yield (SF is 24%). Using 933 MWh/3361 GJ totally to cover the annual demand thus makes the Conventional DH system perform worst, with a PR slightly below 58%.

Thus, the overall loss fraction is 34%, 37% and 42%, for the all GRUDIS, hybrid and conventional DH distribution concept, respectively. It is clear that the distribution losses are similar for the hybrid and GRUDIS system, while being higher for the conventional system. For the

¹ PUR foam has different values of thermal conductivity depending on the blowing agent composition and cell size, properties that vary with manufacturer. This is why different values are used for different types of pipes.

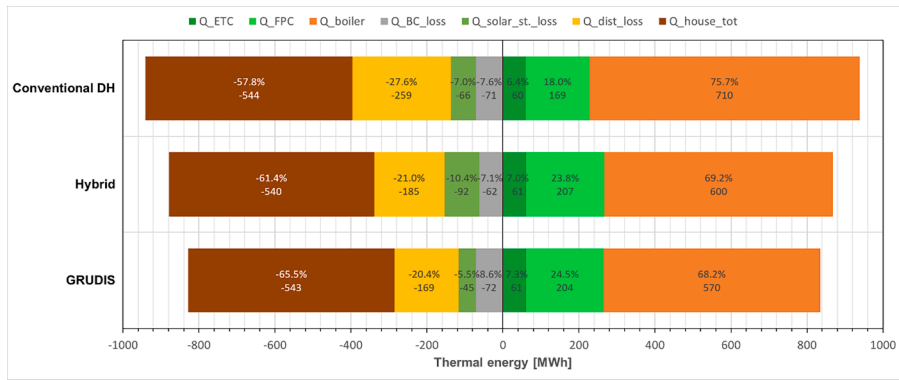

Fig. 7. Energy balance – Simulation results for the three different distribution concepts modelled in this study, showing energy input in positive and output in negative. Abbreviations: Boiler central (BC), evacuated tube collector (ETC) and flat plate collector (FPC).

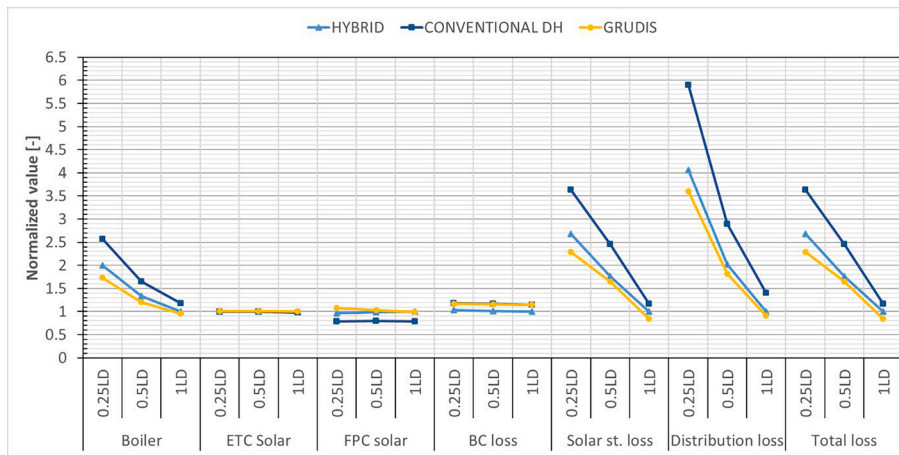

Fig. 8. Parametric study – Influence of linear heat density (LD) on heat input and losses for the three different distribution concepts investigated in this study. The values have been normalised to the simulated values of the hybrid system at 1LD.

conventional and GRUDIS system, the solar storage losses include only the FPC storage losses and internal connection pipes between solar heat exchanger and storage. In the hybrid system, the losses of additional internal connection pipes in the intermediate substation are included, which is why the solar storage losses are higher and the BC losses are correspondingly lower in this system. Therefore, it may be useful to look at the combined solar storage and BC losses in order to evaluate the differences. Looking at combined losses, the shares are quite similar for all systems in relative terms, although the GRUDIS system stands out with lower losses in absolute terms, particularly with regard to solar storage losses. More about this is discussed in section 5.

Sensitivity analysis

Fig. 8 shows the simulation result of a parametric study conducted by variation of the network LD. The values shown are normalised to the simulated values of the hybrid system at 1LD that are shown in Fig. 7. Changing the LD significantly affects distribution heat loss and therefore supplied boiler energy. The boiler energy is paramount, as it directly proportional to wood pellet consumption. The distribution losses vary the most in the conventional DH system with regard to LD and also have the highest normalised values, while the opposite is true for GRUDIS. This is as expected, given that the twin-steel pipes have higher heat losses than EPSPEX culverts. In line with this logic, the hybrid system distribution losses are in between those of the alternative distribution concepts. Looking at the total losses, it is apparent that this overall trend is valid also on a system level, although the discrepancies in BC loss and solar storage loss decreases the difference in performance between the

hybrid and GRUDIS system, while increasing the difference between these and the conventional DH system. At 0.5LD, the fraction of total losses is 45% and 50% for the GRUDIS and hybrid system, respectively. At 0.25LD, these values are 59% and 62%, respectively. In contrast, the loss fraction for conventional DH is 56% and 70% at 0.5LD and 0.25LD, respectively. This indicates that conventional DH is not at all suitable for (very or extremely) sparse DH.

As the GRUDIS system has the lowest distribution and total losses, the normalised boiler energy is also the lowest for all LDs. However, the difference to the hybrid system is very small and as the solar fractions are more or less the same, the results are not entirely conclusive for sparse (1LD) DH. For very (0.5LD) and extremely sparse (0.25LD) DH, on the other hand, as the network density decreases, the overall solar yield increases in the GRUDIS system, while decreasing in the hybrid system and remaining fairly constant in the conventional system.

Table 13

Overview of the estimated distribution network costs for the three distribution concepts evaluated in this study. All costs are in 10³ EUR. *Total costs do not include the costs for a large BC in GRUDIS and conventional DH system.

		Hybrid	GRUDIS	Conventional
Network length (steel/PEX)	[m]	340/2240	-/2580	2580/-
Solar culvert	[m]	280	490	490
Cost pipes	[k EUR]	120	140	130
Cost trench	[k EUR]	460	450	450
Intermediate substation	[k EUR]	240	0	0
House substation	[k EUR]	200	200	600
Total*	[k EUR]	1020	790	1170

However, these changes are rather small compared to those in the total loss (dominated by distribution loss), which increase significantly (although not linearly) as the networks becomes less dense. The combination of high and more increasing losses in the Hybrid and Conventional system, with decreasing or stagnating solar yield, results in a higher increase in boiler energy demand in these systems. The hybrid system uses in excess of 11% and 15% more boiler energy than the GRUDIS system at 0.5LD and 0.25LD, respectively. For the conventional DH system, the additional boiler energy demand exceeds 37% more than that of the GRUDIS system at 0.5LD and 48% at 0.25LD, which confirms that it is indeed unsuitable for sparse systems in general.

The fact that the boiler energy is reduced more with increasing LD in the Hybrid and Conventional DH system than in GRUDIS, indicates that the benefit of increasing heat density is larger for systems using steel pipes and higher network temperatures. Therefore, as heat density increases, it is expected that the differences between system types will decrease in terms of boiler energy and make the performance more similar. This is in line with conclusions from previous studies that have identified both the GRUDIS [30,31,64] system and the use of EPSPEX [34,65] as advantageous in city outskirts, suburbs and other areas with lower LDs.

Cost analysis

Table 13 shows an overview of the network and solar culvert length together with estimated pipe network and substation costs for the three distribution concepts evaluated in this study. Note that the costs for a large BC in the GRUDIS/conventional DH system are excluded. This simple cost analysis reveals that the total estimated cost is the highest for the conventional, while being the lowest for the GRUDIS system. This will be true, as long as the costs to add space for the storage for the FPC collectors to the BC does not exceed 230 k EUR for the GRUDIS system. This is about the same cost as for four intermediate substations, which is unlikely, so the GRUDIS system would probably be least expensive. On the other hand, the large overall cost of the conventional DH system might be difficult to defend when combined with its poor energetic performance. Because the cost of a large BC will be about the same for both the GRUDIS and conventional concept, the latter should be the least favourable option of the three.

Discussion

This section aims to discuss the influence of both the study methodology and, the specific operational factors of the employed distribution concepts, on the resulting energy balance.

Influence of modelling approach on simulation results

The modelling approach is divided into three sections; lumping of components, DHW profile implementation and boundary conditions for pipe sizing.

Lumped modelling approach

There are three lumped subsystem models in this study:

1. Heating load (one house to represent a group of houses).
2. Substation (one substation to represent a group of substations).
3. Pipe elements (one pipe to represent a group of pipes).

The control strategy of the DH system is to maintain a circulation flow rate high enough to secure a maximum temperature decrease of 5 K between network endpoints (10 K in total), in the case of no load. In the hybrid system, this is valid both in the primary and secondary network. In practice, the loads are located at different points in the network, and will thus have different supply temperatures (varying by up to 5 K from lowest to highest). The model has all loads at the end, i.e. the lowest

supply temperature. This has the following impacts:

- Supply temperature in model is lower than in reality.
- Average network temperatures in model lower than in reality.
- Heat losses may be slightly underestimated in model.

In addition to the lumped subsystem models, there is also the lumped component model for the storage tank, where a collection of smaller tanks is modelled as one larger tank with the same surface-to-volume ratio as the smaller tank (see section 3.2). The main differences between the employed model and a more realistic model, is that for a collection of smaller tanks there would have been heat losses associated with connection pipes between the tanks. This means that the absolute value of the storage losses may be slightly underestimated.

Nonetheless; as all three distribution concepts are modelled in the same way, the impacts of all of the above mentioned simplifications are judged to have little impact in the inter-comparison between the concepts. Therefore, because the focus of the study is on comparison of concepts, the results should be representative of the real difference between concepts, although the absolute values may be slightly less accurate.

DHW load modelling

The choice of DHW profile is not straightforward when utilizing scaling in simulation. Using a profile for one house to represent a group of houses would lead to extreme peak values when upscaling to represent a housing area, and low frequency between DHW loads. The effect would be occasional very large swings in return temperature, with unrealistic system behaviour as a result. On the other hand, a profile based on a larger group of houses and scaled down to represent the load of a housing area (hybrid model) or one house (conventional model) would lead to lower peak values and a more constant load, which could reduce dynamic effects on solar yield and boiler energy supply. The approach chosen in this study might lead to slight errors in estimation of solar yield for the various distribution concepts, but the results are considered more comparable between concepts due to less unrealistic behaviours. The DHW load profiles employed in this study are based on the demand of 50 houses, which leads to a smaller coincidence factor and a more flat load profile, than would be the case if the profile was based on 25 houses (one housing area). The difference in coincidence factor between these two DHW profiles makes out roughly 25%, whereas the difference in daily DHW volume is 50% and this leads to a large difference in draw-off frequency that should even out the effect on total solar energy yield and boiler energy supply over time. The full scope of this effect is difficult to assess without further simulations, but is assumed to be of minor importance for the results as the focus of the study is on total energy rather than power.

Flow velocity used for pipe sizing

When dimensioning the distribution network, some assumptions were made regarding accepted continuous flow velocity in the pipes (details in data repository [42]). For the same heat transfer capacity, PEX pipes can be one DN size larger than steel pipes, given that the flow velocity is slightly higher than in steel pipes [32]. Using the same velocity limits for both PEX and steel pipes could require an increase of one additional DN size for some PEX pipe segments, which for the EPSPEX culvert considered in this study corresponds to an increased specific heat loss of roughly 1 W/m on average. The specific heat loss of the GRUDIS distribution network can be calculated to about 7.5 W/m using the values in Fig. 7, which means using standard velocity limits for PEX pipes could potentially result in up to 14% of additional heat loss if all segments would be increased in size. However, how this would influence the results is not straightforward, as the hybrid system consists only partially of PEX and the solar yield plays a role as well.

Conversely, choosing higher velocity limits for all pipes would reduce the simulated heat losses and make the results more even – some

Table 14

Overview of FPC system performance, listing collector array gains, pipe heat losses, stored solar energy and storage losses.

	Collector gain		Pipe heat loss		Stored energy		Storage heat loss	
	[MWh]	[GJ]	[MWh]	[GJ]	[MWh]	[GJ]	[MWh]	[GJ]
GRUDIS	240	863	36	129	204	734	45	161
Hybrid	228	822	23	82	206	740	63	227
Conventional	209	753	41	146	169	607	65	234

sources assume velocity limits as high as 1.5 m/s for copper pipes and above 1.0 m/s in steel pipes. For steel pipes, one DN lower may represent a reduction of the design specific heat loss in the range 1–31% for standard (series 1) twin-pipes in the range DN20 – DN50. Thus, depending on the boundary conditions used for network pipe sizing, the conventional DH system may perform significantly better in terms of distribution heat loss. Despite this, operating temperatures limit the potential solar yield, making it unlikely to compete with the hybrid and GRUDIS system due to high boiler fuel consumption.

Influence of system operating conditions on solar yield and fraction

It is clear from the energy balance presented in Fig. 7 that the solar yield is much lower using the conventional DH concept, than it is in both of the alternative distribution concepts. Table 14 shows an overview of the FPC solar thermal system performance, including collector gains, pipe heat losses in collector circuit, the stored solar energy and the solar storage heat losses. From this, it is clear that:

- Heat losses are higher for conventional DH than the others.
- The collector gain is lower in conventional DH than the others.

In both the hybrid and GRUDIS concept, the FPC arrays are connected to a tank, which is used to prepare DHW by running cold water with an annual average temperature of 10 °C through internal coil heat exchangers. This effectively cools the tank and enables better operating conditions for the solar thermal system. On the other hand, in the conventional DH system, the lowest return temperature is 45 °C, effectively reducing the efficiency of the solar thermal system due to less cooling of the storage and more unfavourable operating conditions.

It should be noted from Table 14 that the GRUDIS and Hybrid concept have similar amounts of stored solar energy despite a difference in collector gains. This can be explained by the larger pipe heat loss in GRUDIS collector circuit, due to the much longer solar culvert. Furthermore, the observed differences in storage loss may be explained

due to the system configuration of the various concepts together with the operating temperatures.

One thing that should be noted with regard to the solar yield is the SFs achieved (see section 4.1). In the conventional system, the SF of 24% corresponds well to the design value of 20% found in literature for diurnal storages (see section 1.2). However, the SF of 31 – 32% for the hybrid and GRUDIS system show that the system configuration and corresponding difference in operating conditions (specifically storage temperature), affects the solar yield positively and that higher SFs are achieved due to more efficient cooling of the solar storage. This can be achieved both in a hybrid system and in a GRUDIS system, as long as the GRUDIS concept is employed for DHW preparation and distribution.

Influence of system configuration on net utilised solar energy

The SF is a measure of the solar energy share of the total energy input, while NUSE is a measure of the how efficiently that energy is used. Although the hybrid and GRUDIS systems have similar SF, the efficient use of this solar energy is less similar between the systems. Fig. 9 shows a plot of the calculated $NUSE_{SYS}$ (eq. (1)) for the summer season (Apr. – Sep.) and annually for all distribution concepts investigated in this study at different LDs. It is apparent that the GRUDIS system performs best of all systems, although the NUSE is still negative on an annual basis. However, at 1LD, the NUSE is positive in the entire summer season for both Hybrid and GRUDIS systems, which indicates that the boiler is shut down more during these months than in the conventional DH system. Although the hybrid concept comes close to the GRUDIS concept in terms of NUSE, the summer values are lower in the hybrid system, which is indicative of a lower overall NUSE.

In the GRUDIS system, the stored solar energy is used to cover the entire network heat loss, while the stored solar energy from FPC is used only for the secondary network in the hybrid concept. This means that the primary network heat loss in the Hybrid system is covered by only ETC solar energy and boiler energy, effectively reducing the NUSE in the system. The lower discharge of energy from the FPC storage in the

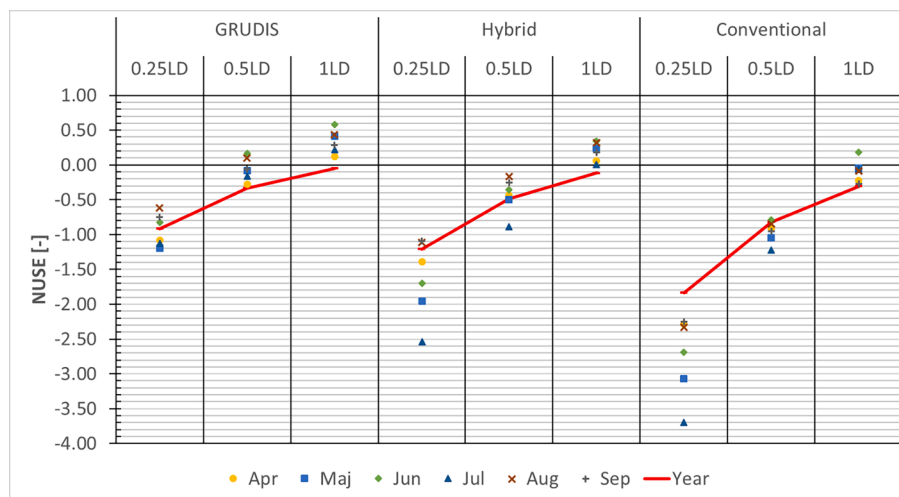

Fig. 9. Plot showing the net utilised solar energy (NUSE) for the summer season (Apr. – Sep.) and annually, for three different line heat densities (LD) and all distribution concepts investigated in this study.

Hybrid system gives higher average storage temperatures, which increases the storage heat loss (see Table 14). A consistently lower discharge leads to higher frequency of overheating in storage, which could explain the lower spread in NUSE values in the summer for the Hybrid system. These results indicate that the solar energy is best stored and used centrally, in order to primarily cover the demand by solar and increase NUSE.

When evaluating the development of NUSE with linear heat density, it can be seen that the increase in annual value is highest for the conventional DH concept. The increase is smallest for the GRUDIS concept, leaving hybrid somewhere in the middle. Again, this is consistent with the results of the sensitivity analysis, showing a correlation between employment of conventional steel pipes, higher operating temperatures and distribution heat loss. The co-variation between distribution heat loss and LD is largest for the conventional DH concept, smallest for the GRUDIS system and somewhere in between for the hybrid system. The reason for the smaller co-variation between heat density and heat loss is due to the NUSE, which varies intricately with the system configuration and is ultimately higher for systems where solar can be used to cover a higher share of the overall heat demand.

Conclusions

A small DH system, consisting of 100 single-family houses with low energy demand divided into four identical subsystems, has been modelled in TRNSYS. In order to reduce modelling effort, common system elements such as buildings and pipes were lumped together, using one building to model a group of 25 buildings and pipe elements to model groups of pipes with the same size. Three different types of distribution system were modelled: One type comprises conventional DH with twin-steel distribution pipes, another type is a GRUDIS system using plastic distribution pipes with DHW-circulation and the last “hybrid” type is a combination of the two other systems with a hydraulic separation in the form of an intermediate substation.

Results give a few clear conclusions:

- Hybrid and GRUDIS distribution is more energy efficient than conventional DH for all heat densities simulated.
- The GRUDIS distribution concept appears to be better from an energy efficiency perspective, with the lowest distribution heat losses, for all heat densities simulated.
- The GRUDIS distribution concept has the highest degree of NUSE, indicating that the relative share of distribution heat losses covered by solar energy is highest in this concept.
- The GRUDIS distribution concepts appears to be the most economical, based on a simple economic analysis considering only piping and substation costs. The conventional system appears to be the most costly.

Future work

A more detailed economic analysis is needed to determine the cost-benefit of the distribution systems investigated in this study and hence, further work should be done to provide this. As a first aim, an economic analysis should focus on the competitiveness of the three distribution systems when including cost differences between them - including detailed installation costs such as costs for welding of connections, costs of bends and tees, and boiler fuel costs, among others. Secondly, the use of higher insulation classes (class 2/3) for steel pipes should be investigated, in order to decide whether the competitiveness of the hybrid and conventional DH system can be increased. Other research efforts should focus on suggested improvements in 4th generation DH systems, such as the use of three-pipe systems with or without local DHW preparation or using heat exchangers with long thermal lengths [36].

CRedit authorship contribution statement

Martin Andersen: Conceptualization, Visualization, Project administration, Writing – original draft, Data curation, Formal analysis, Validation, Software, Methodology, Writing – review & editing. **Chris Bales:** Conceptualization, Funding acquisition, Supervision, Writing – review & editing. **Jan-Olof Dalenbäck:** Funding acquisition, Supervision, Writing – review & editing.

Declaration of Competing Interest

The authors declare that they have no known competing financial interests or personal relationships that could have appeared to influence the work reported in this paper.

Data availability

Datasets related to this article can be found in a data repository provided by Mendeley Data [42].

Acknowledgements

This work was supported by the Marie-Curie Actions Initial Training Network (FP7) of the European Union through the SolNet-SHINE program (Grant agreement ID: 317085).

References

- [1] Mathiesen BV, Bertelsen N, Schneider NCA, Garcia LS, Paardekooper S, Thellufsen JZ, et al. Towards a decarbonised heating and cooling sector in Europe Unlocking the potential of energy efficiency and district energy. 2019. https://vbn.aau.dk/ws/portalfiles/portal/316535596/Towards_a_decarbonised_H_C_sector_in_EU_Final_Report.pdf.
- [2] Weiss W, Spörk-Dür M. Solar Heat Worldwide 2020 - Global market development and trends in 2019. vol. 16. Gleisdorf, Austria: 2020. <https://www.iea-shc.org/solar-heat-worldwide>.
- [3] Eurostat. Eurostat; Renewable energy for heating and cooling 2020. <https://ec.europa.eu/eurostat/web/products-eurostat-news/-/DDN-20200211-1>; Last accessed April 21, 2021.
- [4] REN21. Renewables 2020; Global status report. Paris, France: 2020. [https://abdn.pure.elsevier.com/en/researchoutput/ren21\(5d1212f6-d863-45f7-8979-5f68a61e380e\).html](https://abdn.pure.elsevier.com/en/researchoutput/ren21(5d1212f6-d863-45f7-8979-5f68a61e380e).html).
- [5] Fabiani Appavou, Adam Brown, Bärbel Epp, Duncan Gibb, Bozhil Kondev, Angus McCrone, Hannah E. Murdock, Evan Musolino, Lea Ranalder, Janet L. Sawin, Kristin Seyboth, Jonathan Skeen FS. Renewables 2019 Global Status Report. 2019. <https://wedocs.unep.org/bitstream/handle/20.500.11822/28496/REN2019.pdf?sequence=1&isAllowed=y%0Ahttp://www.ren21.net/cities/wp-content/uploads/2019/05/REC-GSR-Low-Res.pdf>.
- [6] Lund H, Werner S, Wiltshire R, Svendsen S, Thorsen JE, Hvelplund F, et al. 4th Generation District Heating (4GDH). Integrating smart thermal grids into future sustainable energy systems. Energy 2014;68:1–11. <https://doi.org/10.1016/j.energy.2014.02.089>.
- [7] Werner S. Fourth Generation of District Heating Technology. Fininish Dist Heat Days 2017 2017:13. <https://www.4dh.eu/resources/publications>; Last accessed November 25, 2020.
- [8] Fisch N, Kübler R. Solar assisted district heating-status of the projects in Germany. Int J Sol Energy 1997;18:259–70.
- [9] Mauthner F, Herkel S. IEA SHC Task 52: Solar heat and Energy Economics in Urban Environments - Technical Report Subtask C – Part C1. 2016. <http://task52.iea-shc.org/publications>.
- [10] Nielsen C, Haegermark M, Dalenbäck JO. Analysis of a novel solar district heating system. Eurosun 2014;2014:16–9.
- [11] Mauthner F, Joly M. IEA SHC Task 52: Solar heat and Energy Economics in Urban Environments - Technical Report Subtask B/C – Part B3/C2. 2017.
- [12] Dalenbäck J-O. Central Solar Heating Plants with Seasonal Storage - Status Report (D14:1990). Swedish Council for Building Research; 1990. http://archive.iea-shc.org/publications/downloads/Task_7-Central_Solar_Heating_Plants_with_Seasonal_Storage-Status_Report-June_1990.pdf.
- [13] Tian Z, Zhang S, Deng J, Fan J, Huang J, Kong W, et al. Large-scale solar district heating plants in Danish smart thermal grid: developments and recent trends. Energy Convers Manag 2019;189:67–80. <https://doi.org/10.1016/j.ENGCONMAN.2019.03.071>.
- [14] Perez-Mora N, Bava F, Andersen M, Bales C, Lennermo G, Nielsen C, et al. Solar district heating and cooling: a review. Int J Energy Res 2018;42:1419–41. <https://doi.org/10.1002/er.3888>.

- [15] Hsieh S, Omu A, Orehounig K. Comparison of solar thermal systems with storage: from building to neighbourhood scale. *Energy Build* 2017;152:359–72. <https://doi.org/10.1016/j.enbuild.2017.07.036>.
- [16] Yang L, Entchev E, Rosato A, Sibilio S. Smart thermal grid with integration of distributed and centralized solar energy systems. *Energy* 2017;122:471–81. <https://doi.org/10.1016/j.energy.2017.01.114>.
- [17] Rad FM, Fung AS, Rosen MA. An integrated model for designing a solar community heating system with borehole thermal storage. *Energy Sustain Dev* 2017;36:6–15. <https://doi.org/10.1016/j.esd.2016.10.003>.
- [18] Fink C, Riva R, Heimrath R, Halmidst C, Kaufmann H. Mosolnet, Endbericht zum gleichnamigen Projekt in der Forschungsausschreibung „Haus der Zukunft“ im Auftrag des BMVIT. Gleisdorf, Austria: AEE Intec, Gleisdorf; 2007.
- [19] Solar District Heating project. Solar District Heating. SDH Platf 2022. <https://www.solar-district-heating.eu/>.
- [20] Olsthoorn D, Haghghat F, Mirzaei PA. Integration of storage and renewable energy into district heating systems: a review of modelling and optimization. *Sol Energy* 2016;136:49–64. <https://doi.org/10.1016/j.solener.2016.06.054>.
- [21] Dalenbäck J, Lennermo G, Andersson-Jessen P-E, Kovacs P. Solvärme i fjärrvärmesystem - utvärdering av primärinkopplade system, rapport 2013:26. Swedish District Heating Association; 2013.
- [22] Epp B, Dalenbäck J. Europe : 23 New and Upgraded Solar District Heating Plants of 190 MWth Start Operation in 2015 2016:1–5. <https://www.solarthermalworld.org/print/68879>; Last accessed November 19, 2021.
- [23] Paulus C, Papillon P. Substations for Decentralized Solar District Heating: Design, Performance and Energy Cost. *Energy Procedia* 2014;48:1076–85. <https://doi.org/10.1016/j.egypro.2014.02.122>.
- [24] Bauer D, Marx R, Drueck H. Solar District Heating Systems for Small Districts with Medium Scale Seasonal Thermal Energy Stores. *Energy Procedia*, vol. 91, The Author(s); 2016, p. 537–45. <https://doi.org/10.1016/j.egypro.2016.06.195>.
- [25] Dahm J. Small district heating systems. Chalmers tekn högskola 1999.
- [26] Olsen PK, Lambertsen H, Hummelshøj R, Böhm B, Christiansen CH, Svendsen S, et al. A new low-temperature district heating system for low-energy buildings. *Proc 11th Int Symp Dist Heat Cool* 2008:1–8.
- [27] Dalla Rosa A, Li H, Svendsen S. Method for optimal design of pipes for low-energy district heating, with focus on heat losses. *Energy* 2011;36:2407–18. <https://doi.org/10.1016/j.energy.2011.01.024>.
- [28] Andrić I, Pina A, Ferrão P, Lacarrière B, Le Corre O. On the performance of district heating systems in urban environment: an energy approach. *J Clean Prod* 2017; 142:109–20. <https://doi.org/10.1016/j.jclepro.2016.05.124>.
- [29] Perzon M, Johansson K, Fröling M. Life cycle assessment of district heat distribution in suburban areas using PEX pipes insulated with expanded polystyrene. *Int J Life Cycle Assess* 2007;12:317–27. <https://doi.org/10.1007/s11367-006-0264-6>.
- [30] Zinko H. GRUDIS-tekniken för värmegles fjärrvärme. 2004.
- [31] Wallentun H, Zinko H. Medieror av plast i fjärrvärme system, FOU 1996:8 (Swedish). Swedish District Heating Association; 1996. <https://docplayer.se/10255693-Medieror-av-plast-i-fjarrvarme-system.html>.
- [32] Gudmundson T. EPSPEX-kulvert: UTFÖRANDE OCH UPPFÖLJNING, FOU 2003:96. Swedish District Heating Association; 2003.
- [33] Persson C, Fröling M, Svanström M. Life cycle assessment of the district heat distribution system - Part 3: use phase and overall discussion (10 pp). *Int J Life Cycle Assess* 2006;11:437–46. <https://doi.org/10.1065/lca2005.08.225>.
- [34] Li H, Svendsen S, Werner S, Persson U, Ruehling K, Felsmann C, et al. Annex X Final report Toward 4 th Generation District Heating : Experience and Potential of Low-Temperature District Heating. IEA Annex X 2014:205. <http://www.iea-dhc.org/the-research/annexes/2011-2014-annex-x/annex-x-project-03.html>.
- [35] Nowak-Octoń M, Octoń P. Thermal and economic analysis of preinsulated and twin-pipe heat network operation. *Energy* 2020;193. <https://doi.org/10.1016/j.energy.2019.116619>.
- [36] Averfalk H, Werner S. Essential improvements in future district heating systems. *Energy Procedia* 2017;116:217–25. <https://doi.org/10.1016/j.egypro.2017.05.069>.
- [37] Lundgren J, Hermansson R. Solar assisted small-scale biomass district heating system in the northern part of Sweden. *Int J Green Energy* 2005;1:467–82. <https://doi.org/10.1081/GE-200038715>.
- [38] Bachmaier A, Narmsara S, Eggers J-B, Herkel S. Spatial distribution of thermal energy storage systems in urban areas connected to district heating for grid balancing. *Energy Procedia* 2015;73:3–11. <https://doi.org/10.1016/j.egypro.2015.07.549>.
- [39] Olsson H, Rosander A. Evaluation of the Solar-Assisted Block Heating System in a Passive House Residential Area - A Master ' s Thesis in Sustainable Energy Systems Chalmers. University of Technology; 2014.
- [40] Fahlén E, Olsson H, Sandberg M, Löfås P, Kilersjö C, Christensson N, et al. Vallda Heberg - Sveriges största passivhusområde med förnybar energi. Göteborg: Lågan 2014. www.laganbygg.se.
- [41] SEL, CSTB, TRNSOLAR, TESS. TRNSYS 17, a TRaNsient System Simulation program - Volume 1, Getting Started 2014;1. <http://www.trnsys.com/>.
- [42] Andersen M. "Data for article: Heat Distribution Concepts for small Solar District Heating Systems – Techno-economic study for low line Heat densities" 2021. <https://doi.org/10.17632/prmkvs9x5p.2>.
- [43] Powerpipe AB. Powerpipe product catalogue 2019:1–144. <http://www.powerpipe.se/sv-produkter/produktkatalog>.
- [44] Elgocell AB, Klingheim M. Personal communication 2019.
- [45] Ingenjörbyråst Andersson & Hultmark AB. Andersson & Hultmark 2021. <http://aohab.se/>; Last accessed April 14, 2021.
- [46] Amnis Systemutveckling. Wikells Sektionsdata 2021. <https://wikells.se/>.
- [47] Zinko H, Böhm B, Kristjansson H, Ottoson U, Råma M, Sipilä K. IEA R&D Programme on "District Heating and Cooling, including the integration of CHP"; Annex VIII, District heating distribution in areas with low heat demand density. 2008. <https://www.iea-dhc.org/the-research/annexes/2005-2008-annex-viii/annex-viii-project-03>.
- [48] Andersen E, Furbo S. Theoretical comparison of solar water/space-heating Combi systems and stratification design options. *J Sol Energy Eng* 2007;129:438–48. <https://doi.org/10.1115/1.2770752>.
- [49] TESS. TESS component libraries - General descriptions 2021:79. http://www.trnsys.com/tess-libraries/TESSLibs17_General_Descriptions.pdf.
- [50] Drück H. Transsolar: Type 340 - MULTIPORT Store Model for TRNSYS 2006:2–27. https://www.trnsys.de/static/788c19e80e1b4e690b35e44b05c8b164/ts_type_34_0_de.pdf; Last accessed March 17, 2021.
- [51] TRNSYS. Trnsys 17-a TRaNsient System Simulation program - volume 4 Mathematical reference 2009. <https://web.mit.edu/parmstr/Public/TRNSYS/04-MathematicalReference.pdf>.
- [52] Effecta Energy Solutions AB. Solfångare - ST2 (in Swedish) 2021. <https://varme.effecta.se/produkter/solfangare/effecta-st2>; Last accessed April 9, 2021.
- [53] Ritter Energie- und Umwelt-technik GmbH & Co. KG. Ritter XL solar 2021. <https://www.ritter-xl-solar.de/>; Last accessed April 9, 2021.
- [54] Angrisani G, Canelli M, Roselli C, Sasso M. Calibration and validation of a thermal energy storage model: influence on simulation results. *Appl Therm Eng* 2014;67: 190–200. <https://doi.org/10.1016/j.applthermaleng.2014.03.012>.
- [55] Jordan U, Vajen K. DHWcalc - Tool for the Generation of Domestic Hot Water (DHW) Profiles on a Statistical Basis 2017;02:22. <http://www.solar.uni-kassel.de/>.
- [56] Wahlström Å, Nordman R, Petterson U. Mätning av kall- och varmvatten i tio hushåll, ER 2008:14. Borås: Swedish Energy Authority; 2008.
- [57] CEN-CENELEC. SVENSK STANDARD SS-EN 806-3:2006; Specifications for installations inside buildings conveying water for human consumption – Part 3: Pipe sizing – Simplified method 2006:14.
- [58] Boverket. Indata för energiberäkningar i kontor och småhus. Karlkrona: Swedish National Board of Housing, Building and Planning; 2007. http://www.boverket.se/globalassets/publikationer/dokument/2007/indata_foer_energi_berakning_i_kontor_och_smahus.pdf.
- [59] Andersen M, Bales C, Dalenbäck J. Techno-economic Analysis of Solar Options for a Block Heating System. In: Martinez V, Gonzalez J, editors. Eurosun 2016; Conf. Proc., Palma de Mallorca (Spain): International Solar Energy Society (ISES); 2016. <https://proceedings.ises.org/?conference=eurosun2016&mode=page>.
- [60] Elgocell AB. Elgocell; Products 2021. <https://elgocell.co.uk/produkter/>; Last accessed April 12, 2021.
- [61] Powerpipe. Powerpipe; Produktkatalog (Swedish) 2018. <https://www.powerpipe.se/sv-produkter/produktkatalog>; Last accessed April 12, 2021.
- [62] Logstor. Logstor 2018. <https://www.logstor.com/catalogues-and-documentation?lang=1737&type=1613>; Last accessed April 12, 2021.
- [63] isoplus Fernwärmetechnik Vertriebsgesellschaft mbH. Isoplus-pipes.com; Download > Design Manual 2012. <https://www.isoplus-pipes.com/download/design-manual.html>; Last accessed April 12, 2021.
- [64] Claesson C. Fjärrvärme Till Småhus – Litteraturstudie 2003 (Swedish). 2004.
- [65] Nilsson SF, Reidhav C, Lygnerud K, Werner S. Sparse district-heating in Sweden. *Appl Energy* 2008;85:555–64. <https://doi.org/10.1016/j.apenergy.2007.07.011>.