



## Recent and future trends of onshore wind turbine foundations

Downloaded from: <https://research.chalmers.se>, 2026-04-03 12:10 UTC

Citation for the original published paper (version of record):

Armesto Barros, J., Mathern, A. (2022). Recent and future trends of onshore wind turbine foundations. Proceedings of the IABSE Symposium Prague 2022: Challenges for Existing and Oncoming Structures

N.B. When citing this work, cite the original published paper.



## Recent and future trends of onshore wind turbine foundations

Jesús Armesto Barros, Alexandre Mathern

NCC, Gothenburg, Sweden

Contact: [jesus.armesto@ncc.se](mailto:jesus.armesto@ncc.se)

### Abstract

The decarbonization of the economy and the growing need for electricity are two trends that call for greener energy sources. Wind is a growing renewable energy source, which is expected to become the first source of power in the European Union in the next decade. In particular, onshore wind energy is expected to double by then. Fundamental structural components of wind turbines are their foundations, which are large structures associated with important material consumption and many construction challenges. The dimensions of these foundations are continuously increasing as turbines with taller towers and larger rotor diameters are being built. Designing cost- and material-efficient foundations is crucial to reduce the economic and environmental impact of wind energy. An important factor to successfully address these evolving requirements in the planning and design process is to build on the experience from previous projects. The aim of this work is to investigate the evolution of onshore wind turbines and its consequences on the design and climate impact of gravity foundations by analysing data from Swedish wind farms set in operation between 2013 and 2022. The evolution of turbine size, and foundation dimensions, reinforcement layout, material types and quantities, and embodied carbon are analysed in this paper.

**Keywords:** Wind energy; wind turbine foundations; reinforced concrete structures; structural design; construction; environmental impact.

### 1 Introduction

Wind energy is the energy source associated with the lowest greenhouse gas emissions during the life cycle of the facility [1]. It has become one of the cheapest energy sources, with a price ranging between 39 €/MWh and 121 €/MWh, to be compared with prices for energy produced from gas and coal, which range between 78 €/MWh and 290 €/MWh (prices based on German locations as of 2021) [2]. In addition, while wind energy costs are lowering as the technology matures [2][3], costs for energy produced from fossil fuel are expected to increase as CO<sub>2</sub> emission rights get more expensive in the future [2].

Consequently, wind energy is expected to have a key role in the development of renewable energy

and electrification for decarbonization of the European Union (EU) in the coming 30 years, growing to produce 50 % of its electricity [3]. In fact, wind is expected to become the first source of power in the EU already during this decade [3].

Sweden's installed capacity represents 5.5 % of EU's capacity. With 10.0 GW it is the fifth country in the EU with most installed capacity (only behind Italy, France, Spain and Germany). Considering all Europe, Sweden ranks sixth (with only the UK having a higher installed capacity besides the previously mentioned countries) [4]. Onshore wind accounts for 98 % of the installed wind power capacity in Sweden, and offshore wind for the remaining 2 % [4].

Sweden produced 27.5 TWh from wind during 2020 [5]. The installed turbines, capacity and

production is growing as shown in Figure 1. The annual production is expected to continue rising for a long period. The Swedish transmission system operator Svenska Kraftnät foresee an installed capacity between 24 GW and 63 GW for the year 2050 [6].

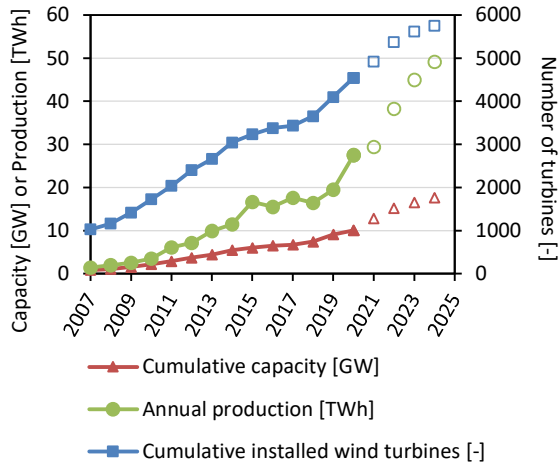

Figure 1. Installed turbines, capacity and annual production from 2007 to 2020 (solid line and filled dots) and prognosis until 2024 (empty dots) [5][7].

The expansion of the installed capacity in Sweden is not only the result of the installation of more turbines but also of the increasing power produced by each one, see Figure 2. A similar trend is observed in Germany, the leading country in installed wind power in Europe [4]. To produce more power, larger turbines with taller towers and/or larger rotor swept area are required, which increases the loads acting on the foundations and therefore their sizes.

Traditionally onshore wind turbine foundations have been designed on a case-by-case basis for each project, something that has led to higher material needs implying higher costs and environmental impact [8].

Due to the functionality of the foundation, the only suitable construction material is reinforced concrete. The exposure of the structure to a humid environment makes steel or timber unsuitable for the job. Furthermore, concrete contributes to achieving the high mass required for gravity foundations to counteract the effect of wind forces.

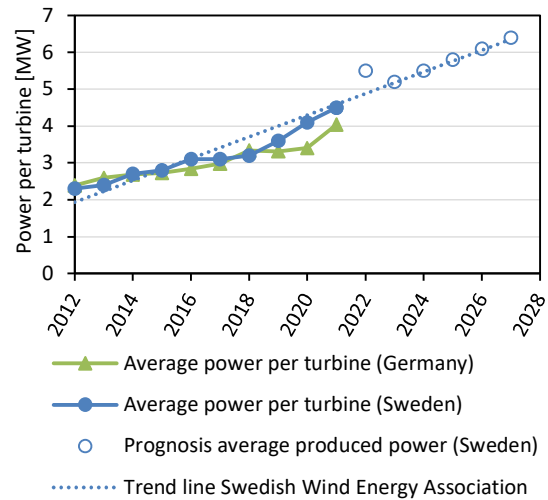

Figure 2. Average produced power per new turbine in Sweden between 2012 and 2021 and prognosis until 2027 [9]; average produced power per new turbine in Germany between 2012 and 2021 [10].

This study analyses data from 13 different Swedish wind projects set in operation between 2013 and 2022. Information about the wind farms such as turbines, capacity or planned production has been gathered. Material from tender processes and building stages has been analysed to evaluate foundation designs with a focus on reinforced concrete gravity foundations. Parameters such as material needs and environmental impact have been studied for the 17 different foundation geometries built in these projects.

## 2 Background

Wind turbines consist of a rotor that, under the effect of the wind, spins around an axis to move an electrical generator. There are vertical axis and horizontal axis wind turbines. This study focuses on the latter, which have been the dominant type on the market.

For horizontal axis wind turbines, the generator is placed in a nacelle, which is often set on top of a tubular tower. A hub connects the blades to the main shaft that transfers the rotational energy to the generator. Important parameters to define the system are the hub height ( $H_{T1}$ ), the rotor diameter ( $D_R$ ) and total height ( $H_{T2}$ ), as depicted in Figure 3.

Wind turbines might be installed onshore or offshore. For onshore foundations the structure usually consists of a reinforced concrete thick slab with an embedded bolt cage connecting to the tower. This may be formed as a gravity foundation, a piled foundation, or a posttensioned foundation attached to bedrock.

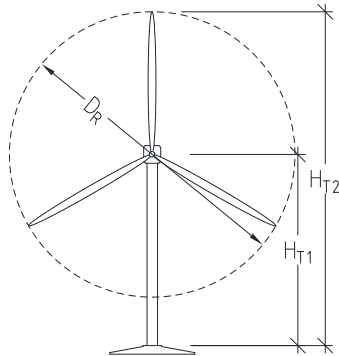

Figure 3. Parameters defining main dimensions on a turbine.  $H_{T1}$ : hub height;  $H_{T2}$ : total height;  $D_r$ : rotor diameter.

Loading from the tower is transferred into the foundation via the bolt cage. The effects are depicted in Figure 4, and can be simplified in four different loads in relation with the wind direction:

- Moment about a horizontal axis perpendicular to wind,  $M_r$ .
- Force in wind direction,  $F_r$ .
- Moment about a vertical axis,  $M_z$ .
- Force in vertical direction,  $F_z$ .

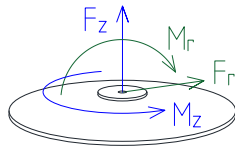

Figure 4. Loading transferred from tower to foundation.

The base of a gravity foundation may have different shapes like circular, squared or another regular polygon. The thickness of the slab may be constant or vary from the sides towards the centre where the section often rises in a pedestal, see Figure 5. The different geometrical parameters gathered in the study are presented in the figure below.

Bending reinforcement may be set in a radial-tangential layout (B and C in Figure 5) or in an orthogonal grid (D in Figure 5). Shear reinforcement (A in Figure 5) may be executed as stirrups or using T-headed bars.

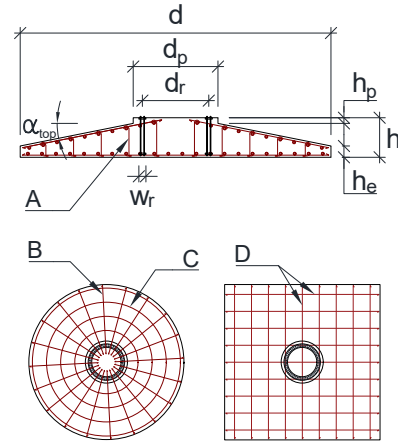

Figure 5. Geometry parameters for gravity foundations and possible reinforcement layouts (in red). A: shear reinforcement; B: radial reinforcement; C: tangential reinforcement; D: orthogonal layout for reinforcement.

### 3 Method

The data used in the study was gathered from 13 different wind farms in Sweden. In some of these farms, different foundation geometries were used due to varying geotechnical properties. This resulted in 17 different gravity foundation geometries being analysed in this study.

These 13 wind farms represent a total of 1 094 turbines. The turbine rated power varies from 3.0 MW to 6.2 MW, with an average of 4.6 MW. The total installed power is 5 100 MW and the expected yearly production for all the analysed wind farms is 10.3 TWh. This corresponds to 37 % of the electricity production from wind in Sweden in 2020 [5]. The availability of both wind turbine and foundation data governed the selection of these wind farms.

The evolution of various data (i.e., turbine sizes, loads, geometry, materials characteristics, and quantities) was analysed. The embodied carbon emissions for the main construction materials were assessed to estimate the environmental impact of

the foundations. The emissions were calculated using values for the total global warming potential (GWP), measured in carbon dioxide equivalent (CO<sub>2</sub>e), for modules A1-A3 (product stage) from relevant environmental product declarations (EPDs). EPDs for different classes of concrete from InformationsZentrum Beton GmbH verified by the Institut Bauen und Umwelt e. V. (IBU) [11] were used for the concrete materials, and EPD-based values from the climate assessment tool Klimatkalkyl from the Swedish Transport Administration [12] were used for the reinforcing steel and the galvanized steel bolts.

## 4 Data analysis

### 4.1 Evolution of turbine technology

The studied wind farms show how fast onshore wind turbines have developed in the past ten years. Turbine rated power has doubled, from 3.0 MW in 2013 to 6.2 MW in 2022, see Figure 6. The analysed turbines are relatively close to the trend line for Swedish wind farms installations shown in Figure 2, although turbines installed since 2020 have markedly higher power than foreseen.

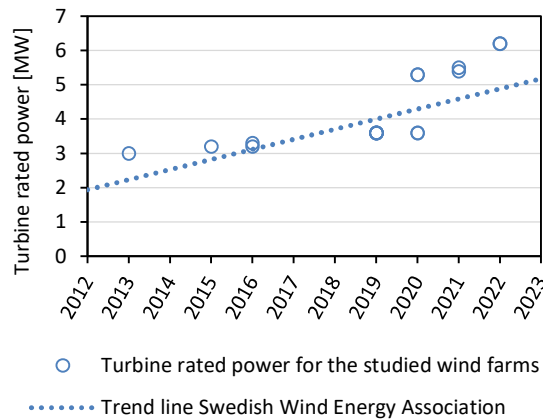

Figure 6. Evolution of turbine rated power in the analysed wind farms and comparison with trend line from Figure 2 [9].

All wind turbines and their foundations were designed for a service life varying between 20 and 30 years.

Tower dimensions go from 91 m to 141 m for hub height, 112 m to 170 m for rotor diameter and

150 m to 220 m in total height. Average dimensions for each year with available data are shown in Figure 7. Rotor diameter has increased continuously in the past years while hub height has decreased some years, as observed in Figure 7.

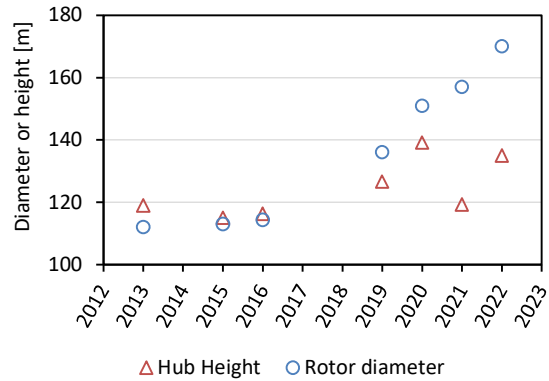

Figure 7. Evolution of rotor diameter and hub height, average values per year.

The relation between rotor diameter and turbine rated power is clearer than for hub height and turbine rated power, as seen in Figure 8.

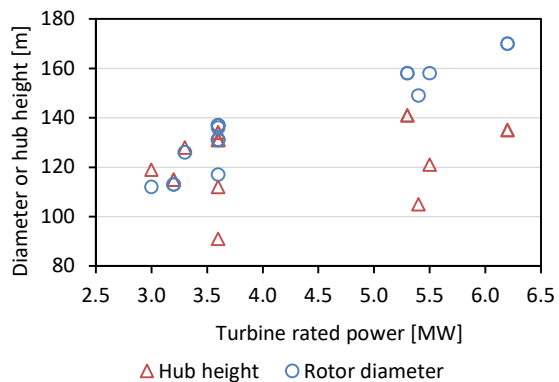

Figure 8. Relation between hub height or rotor diameter, and turbine rated power.

One of the wind farms analysed was divided in two different construction stages: one set in operation in 2019 and the second in 2021. It is worth noting that the limit in total height did not stop technology evolving to more powerful turbines, as shown in Table 1. By decreasing hub height and increasing instead rotor diameter, power went up by 52 % without changing the total height of the turbine.

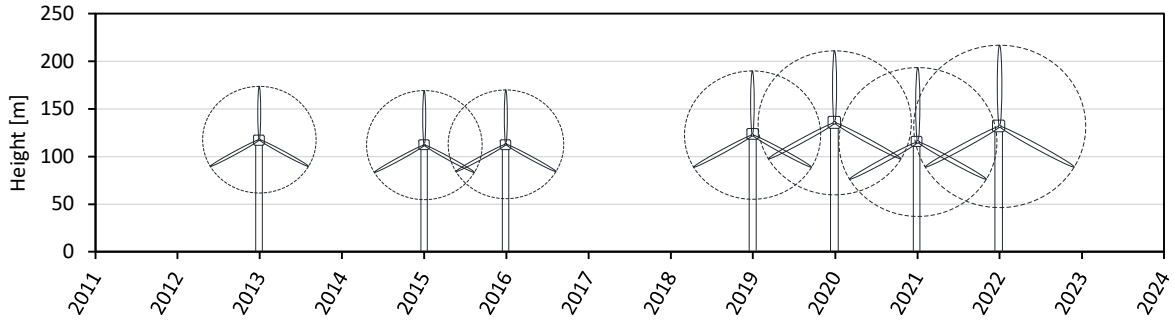

Figure 9. Average dimensions of turbines for the analysed wind farms.

Table 1. Comparison of turbine characteristics between two stages of a wind farm.

|                            | Stage 1 | Stage 2 |
|----------------------------|---------|---------|
| Start of operation         | 2019    | 2021    |
| Hub height, $H_{T1}$ [m]   | 131     | 121     |
| Total height, $H_{T2}$ [m] | 200     | 200     |
| Rotor Diameter, $D_R$ [m]  | 137     | 158     |
| Power per turbine [MW]     | 3.6     | 5.5     |

## 4.2 Evolution of loads on foundations

Loading increases with the turbine rated power. The design moment  $M_r$  in the ultimate limit state (ULS) is plotted in Figure 10. The other load effects ( $F_R$ ,  $M_z$  and  $F_z$ ) also increase proportionally.

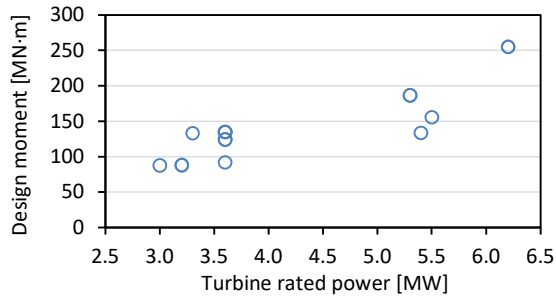

Figure 10. Relation between design moment in ULS at tower base and turbine rated power.

## 4.3 Evolution of foundations

All analysed turbines are supported by gravity foundations with varying shapes. Two of them have a square base with constant thickness while the

rest present a circular base with a varying thickness.

Foundations have followed the size evolution of the turbines, with their volume increasing from 350 m<sup>3</sup> to 1150 m<sup>3</sup>. Table 2 presents minimal, average, and maximal values for the geometry parameters introduced in Figure 5.

Table 2. Minimal, average, and maximal values for geometry parameters.

|                                | Min                | Mean | Max  |      |
|--------------------------------|--------------------|------|------|------|
| Base diameter                  | d [m]              | 18.0 | 23.6 | 28.4 |
| Pedestal diameter              | $d_p$ [m]          | 4.6  | 6.4  | 10.3 |
| Bolt cage diameter             | $d_r$ [m]          | 3.9  | 4.9  | 7.7  |
| Bolt cage flange width         | $w_r$ [m]          | 0.4  | 0.5  | 0.6  |
| Height pedestal                | h [m]              | 2.0  | 2.9  | 3.6  |
| Min height flange              | $h_e$ [m]          | 0.4  | 0.5  | 0.9  |
| Height of pedestal over flange | $h_p$ [m]          | 0.2  | 0.5  | 0.9  |
| Angle top face of pedestal(*)  | $\alpha_{top}$ [°] | 10.4 | 13.4 | 16.2 |

(\*) Foundations with constant thickness not included

The general concrete class in foundations has been chosen equal to C35/45 in all cases except one, for which C30/37 was used. Hence, the average characteristic compressive cylinder strength is 34.9 MPa. A higher compressive strength is usually required for the pedestal due to the more concentrated load effects from the tower in that area. Of special consideration is the grouting under

the tower flange, which presents a class varying between C60/75 and C90/105, with an average characteristic compressive cylinder strength of 85.2 MPa.

The steel reinforcement used in all the foundations has a characteristic yielding strength of 500 MPa. The foundations with square base have orthogonal bending reinforcement and regular stirrups as shear reinforcement. The ones with circular base have a radial-tangential layout for bending reinforcement and T-headed bars as shear reinforcement.

The relation between material quantities and loading from the towers is shown in Figure 11, where concrete volumes, reinforcement masses and bolt masses are plotted against design bending moment ( $M_r$ ) in ULS. The use of all materials increases with the bending moment.

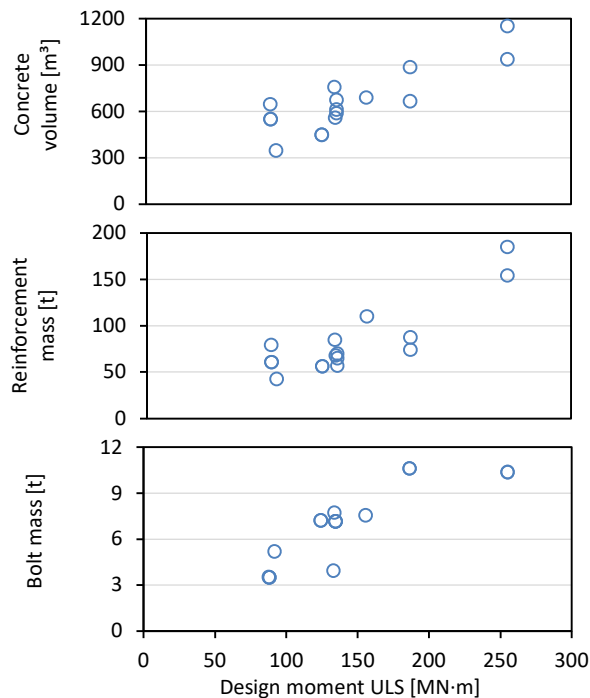

Figure 11. Relation between concrete volume, reinforcement mass and bolt mass, and design moment in ULS.

#### 4.4 Environmental impact of foundations

In this section the environmental impact of the foundations is estimated based on the embodied carbon of the main construction materials.

In an attempt to analyse how material efficient a foundation is in relation with the power production of the turbine, the ratio between the GWP and the turbine rated power is evaluated. This ratio is compared to the turbine rated power in Figure 12. No clear trend can be observed when comparing the ratio between GWP and power with turbine rated power. Foundations for turbines from 3.0 MW to 5.5 MW get slightly more efficient for higher powers. However, a decrease in efficiency can be observed for turbines with a rated power of 6.2 MW.

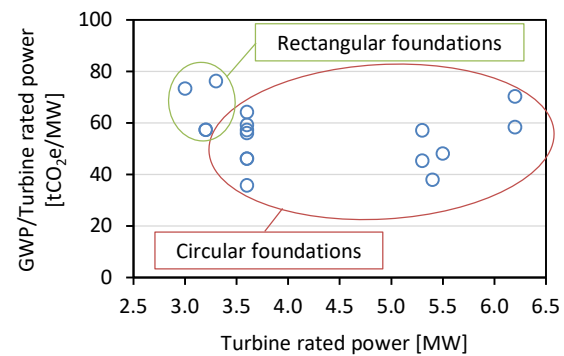

Figure 12. Relation between the GWP to power ratio and the turbine rated power.

Further analysis of the GWP shows a constant increase when compared with the design bending moment, see Figure 13.

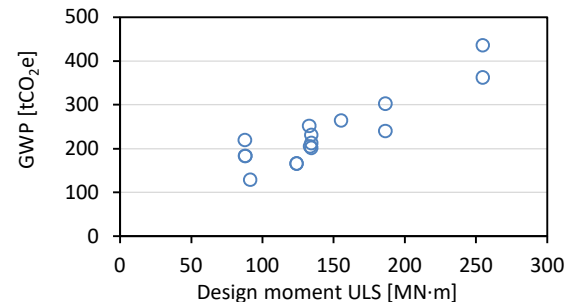

Figure 13. Relation between GWP and design moment in ULS.

Figure 14 shows the relation between the ratio of GWP to design bending moment and the turbine rated power. Two categories can be observed: foundations with rectangular base and constant thickness (marked as “rectangular foundation”) and foundations with a circular base and varying thickness (marked as “circular foundation”).

Rectangular foundations can be regarded as less material efficient for loading conditions than gravity foundations on this data set, as all of them presented a constant thickness. For circular foundations, the ratio of GWP to design bending moment remains relatively constant for different turbine rated powers.

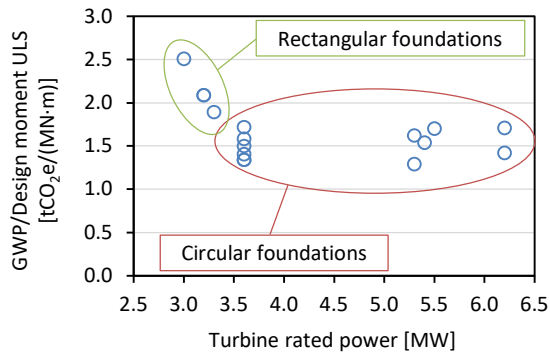

Figure 14. Relation between the ratio of GWP to design moment in ULS and turbine rated power.

## 5 Discussion

Although wind energy is generally considered to be a mature technology, turbine characteristics have been evolving significantly over the past ten years. Additionally, the current focus on mitigating climate change makes the reduction of embodied carbon in construction a priority for stakeholders involved in the design and construction of wind farms. Structural engineers have an important role to play in supporting this effort.

All the foundations analysed in this work consist in a massive volume of reinforced concrete. Square-shaped foundations that were used ten years ago seem to have been abandoned for circular foundations. Today, a greater emphasis needs to be placed on rational use of resources and for that, materials must be used more effectively. The shift from square- to circular-shaped foundations appears to have improved the environmental performance of the foundations. To make further progress, concrete should only be used for its structural capacity and not as a counterweight, for instance by using other geometries such as ribbed foundations in combination with more environmentally friendly materials (e.g. soil or aggregates) as counterweight. Massive foundations have traditionally been favoured by

their ease of construction. Nevertheless, challenges associated with the construction of foundations with more complex shapes may be bypassed by adopting a higher level of prefabrication and alternative construction methods.

Reducing the environmental impact of foundations also entails adequate choices of concrete material. Almost all the studied foundations presented the same general concrete class, which raises the question whether the type of concrete can be chosen more efficiently. Higher concrete classes require more cement, which increases the emissions of CO<sub>2</sub>. The concrete class is limited by several factors such as strength requirements and exposure classes. However, a reduction of 1 or 2 concrete classes may be possible for most of the analysed wind farms, which would contribute to lower the climate impact. The use of cement replacement materials (e.g. fly ash and ground granulated blast furnace slag), would also contribute to significantly reducing the environmental impact of foundations [13].

The size of the studied turbines has grown over time following their increasing rated power; this observation matches the trend observed in Sweden and Germany, recall Figure 2.

Nevertheless, the development of the size of onshore wind turbines may reach a limit at some point, e.g., due to transportation issues for larger and heavier components, scaling issues for loading and material resistance, or limitations from building permits. It seems realistic that onshore turbines will face difficulties in following the constant height increase of offshore wind turbines. This limitation may become an opportunity: increasingly stable turbine dimensions, and hence the loads acting on the foundation, would open for reuse of foundations when retrofitting a wind farm. To do so, a longer service life would need to be accounted for in the design (in particular with regard to fatigue loads) or structural health monitoring would need to be used during operation to assess the remaining fatigue life at the end of the design service life.

Optimization of foundations or extension of their service life call for a more integrated design approach than the current practice, i.e. closer

collaboration between wind farms developers, turbine designers, foundation and tower designers and suppliers.

## 6 Conclusions

The constant evolution of onshore wind turbines, marked by their increasing capacity, requires larger foundations to withstand the higher loads.

As it becomes more and more important to reduce the environmental impact of wind farms, more attention needs to be given to rationalising the use of resources to build foundations. This can be achieved through structural optimization focused on finding adequate geometries, selecting the right concrete classes, and using cement replacement materials. A further development would be to investigate the potential of extending the lifetime of foundations in connection with a replacement or a lifetime extension of the turbines.

## 7 Acknowledgments

This work is financially supported by the Swedish Wind Power Technology Centre (SWPTC) and the construction company NCC. SWPTC is a research centre for the design of wind turbines. The purpose of the centre is to support Swedish industry with knowledge of design techniques as well as maintenance in the field of wind power. The centre is funded by the Swedish Energy Agency, Chalmers University of Technology as well as academic and industrial partners.

## 8 References

- [1] Schlömer S., Bruckner T., Fulton L., Hertwich E., McKinnon A., Perczyk D., et al. *Annex III: Technology-specific cost and performance parameters. In: Climate Change 2014: Mitigation of Climate Change. Contribution of Working Group III to the Fifth Assessment Report of the Intergovernmental Panel on Climate Change*. Cambridge and New York: Cambridge University Press; 2014.
- [2] Fraunhofer Institute for Solar Energy Systems ISE. *Levelized cost of electricity renewable energy technologies*. Freiburg; 2021.
- [3] European Technology & Innovation Platform on Wind Energy & WindEurope. *Getting fit for 55 and set for 2050*. Brussels; 2021.
- [4] WindEurope. *Wind Energy in Europe; 2020 Statistics and the outlook for 2021-2025*. Brussels; 2021.
- [5] Svensk Vindenergi. *Statistics and forecast 2021 – Q2*. Stockholm; 2021.
- [6] Svenska Kraftnät. *Långsiktig marknadsanalys 2021*. Sundbyberg; 2021.
- [7] Svensk Vindenergi. *Vindkraftstatistik kvartal 1 2013*. Stockholm; 2013.
- [8] Mathern A., Penades Plà V., Armesto Barros J. and Yepes V. *Practical metamodel-assisted multi-objective design optimization for improved sustainability and buildability of wind turbine foundations*. Submitted for publication.
- [9] Svensk Vindenergi [Internet]. Stockholm; 2021 [cited 2021 Sep 14]. Available from: <https://swedishwindenergy.com/wind-power/statistics/2017-3>
- [10] Bundesverband WindEnergie [Internet]. Berlin; 2022 [cited 2022 Jan 17]. Available from: <https://www.wind-energie.de/themen/zahlen-und-fakten/deutschland/>
- [11] Becke A., Reiners J. and Tuan Phan A. *Erläuterungen zu den Umweltproduktdeklarationen von Beton*. Düsseldorf: InformationsZentrum Beton GmbH; 2020.
- [12] Trafikverket [Internet]. *Klimatkalkyl (Version 7.4.1.2) [Data set]*. Stockholm; 2021 [Cited 2021 Sep 20]. Available from: <https://klimatkalkyl.pub.ea.trafikverket.se/Klimatkalkyl/>
- [13] Berndt M. L. *Influence of concrete mix design on CO2 emissions for large wind turbine foundations*. *Renewable Energy*. 2015 Nov; 83 (11): 608-614.