



A Collaborative System of Flying and Ground Robots with Universal Physical Coupling Interface (PCI) and the Potential Interactive

Downloaded from: <https://research.chalmers.se>, 2026-04-04 16:28 UTC

Citation for the original published paper (version of record):

Wang, Z., Hu, Z., Man, Y. et al (2022). A Collaborative System of Flying and Ground Robots with Universal Physical Coupling Interface (PCI) and the Potential Interactive Applications. CHI EA '22: Extended Abstracts of the 2022 CHI Conference on Human Factors in Computing Systems. <http://dx.doi.org/10.1145/3491101.3519766>

N.B. When citing this work, cite the original published paper.

A Collaborative System of Flying and Ground Robots with Universal Physical Coupling Interface (PCI) and the Potential Interactive Applications

Ziming Wang

Chalmers University of Technology, Gothenburg, Sweden
University of Luxembourg, Esch-sur-Alzette, Luxembourg
ziming@chalmers.se

Yemao Man

ABB UX Researcher Group
Västerås, Sweden
yemao.man@se.abb.com

Ziyi Hu

Chalmers University of Technology
Gothenburg, Sweden
hziyi@student.chalmers.se

Morten Fjeld

Chalmers University of Technology, Gothenburg, Sweden
University of Bergen, Bergen, Norway
fjeld@chalmers.se

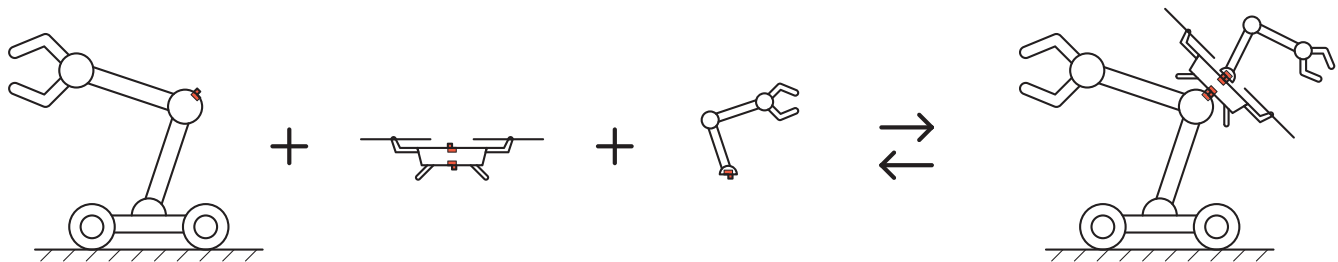

Figure 1: A collaborative system with universal physical coupling interfaces (PCIs) can support diverse ground/flying robot combinations; PCIs are indicated in red.

ABSTRACT

Flying and ground robots complement each other in terms of their advantages and disadvantages. We propose a collaborative system combining flying and ground robots, using a universal physical coupling interface (PCI) that allows for momentary connections and disconnections between multiple robots/devices. The proposed system may better utilize the complementary advantages of both flying and ground robots. We also describe various potential scenarios where such a system could be of benefit to interact with humans - namely, remote field works and rescue missions, transportation, healthcare, and education. Finally, we discuss the opportunities and challenges of such systems and consider deeper questions which should be studied in future work.

CCS CONCEPTS

• **Computer systems organization** → **External interfaces for robotics**; • **Human-centered computing** → **Collaborative interaction**.



This work is licensed under a Creative Commons Attribution International 4.0 License.

CHI '22 Extended Abstracts, April 29-May 5, 2022, New Orleans, LA, USA
© 2022 Copyright held by the owner/author(s).
ACM ISBN 978-1-4503-9156-6/22/04.
<https://doi.org/10.1145/3491101.3519766>

KEYWORDS

universal physical coupling interface (PCI), collaborative system, flying and ground robots, human-robot interaction

ACM Reference Format:

Ziming Wang, Ziyi Hu, Yemao Man, and Morten Fjeld. 2022. A Collaborative System of Flying and Ground Robots with Universal Physical Coupling Interface (PCI) and the Potential Interactive Applications. In *CHI Conference on Human Factors in Computing Systems Extended Abstracts (CHI '22 Extended Abstracts)*, April 29-May 5, 2022, New Orleans, LA, USA. ACM, New York, NY, USA, 7 pages. <https://doi.org/10.1145/3491101.3519766>

1 INTRODUCTION

The fourth industrial revolution strongly emphasizes cyber-physical systems [17], where the internet of things (IoT) becomes both more ubiquitous across society and more integrated in everyday use [37, 38]. Devices become “smart” in the sense that they can access the internet and communicate with other devices, thereby managing ranges of tasks more effectively [42, 46]. While most smart devices connect, communicate, and disconnect virtually through the internet, using purely virtual connection presents both challenges and opportunities [56].

We propose a coupling strategy where mobile smart devices, as well as their users, will benefit from momentary physical connection supporting applications such as battery charging, rapid and stable transmission of sensitive data, and so forth. Making use of physical infrastructure as an interface to couple two or more autonomous devices would enable them to operate jointly when needed, while at

other times collaborating at a distance or operating independently. Such systems, embracing the IoT features plus allowing physical coupling of multiple devices, could take advantage of these objects' complementary capabilities. The coupled devices would thus be able to carry out a greater diversity of tasks, leading to new kinds of services, interactions, and experiences for users in a variety of settings, from domestic to industrial ones.

In this paper, we present a concept for a universal physical coupling interface (PCI) that allows for momentary connections and disconnections of multiple devices (see example in Figure 1). Here, the term "universal" means it is standard, modular and scalable, and designed to be applicable for all kinds of devices via the same protocol for communications. We mainly focus on the collaborative system of a ground robot and a flying robot using PCI; other kinds of primitives, e.g., ground-ground robots, flying-flying robots, systems of more than two devices and so on, are not yet studied here. We also demonstrate a variety of potential scenarios and features where the studied system could be of benefit when interacting with human users. Finally, the challenges affecting implementations of such systems and deeper questions that must be studied in future work will be discussed.

2 RELATED WORK

The definition of "Robot" is adapted from ISO 8373:2021 as a "programmed actuated mechanism with a degree of autonomy to perform locomotion, manipulation or positioning", where autonomy is specified as the "ability to perform intended tasks based on current state and sensing, without human intervention", including both industrial robots and service robots [15]. Hence, robots can be autonomous or semi-autonomous.

Flying robots or unmanned aerial vehicles (UAVs), commonly known as drones, are agile and can access a relatively large workspace. Drones can already be used in everyday life and work and will become more commonplace [1, 34, 44]. However, one weak point of drones is their short battery life [50]. There exist some solutions for the battery shortage of drones [6, 7, 10, 25, 53], including utilizing ground robots to replenish or exchange drone batteries [3, 33]. A ground robot can be either fixed in place or mobile, such as a mechanical arm, a vehicle with autonomous features, or even a prosthetic limb, all of which have fewer power supply constraints compared to a drone, as they usually have direct connection to electricity or higher capacity batteries [30, 33]. A ground robot has better capabilities than a flying robot regarding extensibility and can be more flexibly integrated with various hardware and software, due to its higher power capacity and larger payload which allows it to carry more powerful computers, more complex sensors and actuators to execute tasks [30, 33]. However, compared to a drone, the workplace of a ground robot is limited and relatively two-dimensional (2D), as its sensor and actuator ranges are limited by the fact that it's on the ground. The drone is much more agile and can rapidly respond to changes when needed due to the limited ground robot speed [2]. Table 1 shows these complementary advantages of ground robots, flying robots, and targeted ground/flying robot combinations.

Collaborative systems of coupling flying and ground robots have been proposed in several different embodiments. Miki et al. designed

Table 1: Complementary advantages of ground robots, flying robots, and targeted ground/flying robot combinations.

	Ground Robots	Flying Robots	Targeted Systems
Workspace	▲	●	●
Power Supply	●	▲	●
Extension Capability	●	▲	●
Agility	▲	●	●

●=advantage ▲=disadvantage

a system in which a UAV assists an unmanned ground vehicle (UGV) to climb cliffs by attaching a tether, in order to conduct missions that neither UAV nor UGV could accomplish alone [30]; nonetheless, the system didn't solve the UAV battery problem, and power supply and communication via the tether was suggested for the future work [30]. Power tethered UAV/UGV systems had already been developed [9, 21, 36, 54], but the tether would add extra weight and restrict the workspace of the robots as well as perhaps twist or entangle objects, causing safety issues. Narváez et al. presented a ground manipulator able to autonomously dock a UAV for its battery replenishment [33]; similarly, Barrett et al. presented a system enabling autonomous battery exchange for UAVs by using a robotic ground base, which greatly extended the endurance of the UAV [3]. However, these required extra space on board to store the batteries and the exchange procedures were somewhat complicated, and the ground base did not have any functions other than battery exchange.

These previous works indicated the potential benefit of utilizing the advantages of both flying and ground robots, but how the two kinds of robots connected was somewhat complex and bothersome, and requires some better solution. Moreover, most aforementioned collaborative systems lacked consideration of how such systems would interact with humans.

Some joint solutions have been studied, including physical interfaces augmenting physical capabilities [23], interfaces for ubiquitous grasping [52], interfaces that can stick to different kinds of surfaces [51], a modular interface for physical objects held on the back surface of smartphones [29], as well as some conceptual ideas [11, 31, 35]. These projects show various ways for conveniently joining different objects.

We have found projects and ideas with elements partly similar to our proposal. For instance, collaborative systems of flying-ground robots with elaborate connecting solutions [3, 9, 21, 30, 33, 36, 54] and convenient solutions joining different objects other than robots [11, 23, 29, 31, 35, 51, 52] have been proposed. However, none of these systems combine collaborative flying-ground robots with a simple joint solution coming close to our proposed concept (see Figure 2), presented next.

3 PROPOSED CONCEPT

Partially inspired by the existing solutions, we come up with an idea of a universal physical coupling interface (PCI), as illustrated in Figure 3, which is the core component of our proposed system (shown in Figure 2). The coupler has a specific shape for clamping, fastening the two devices together. A durable material is chosen to

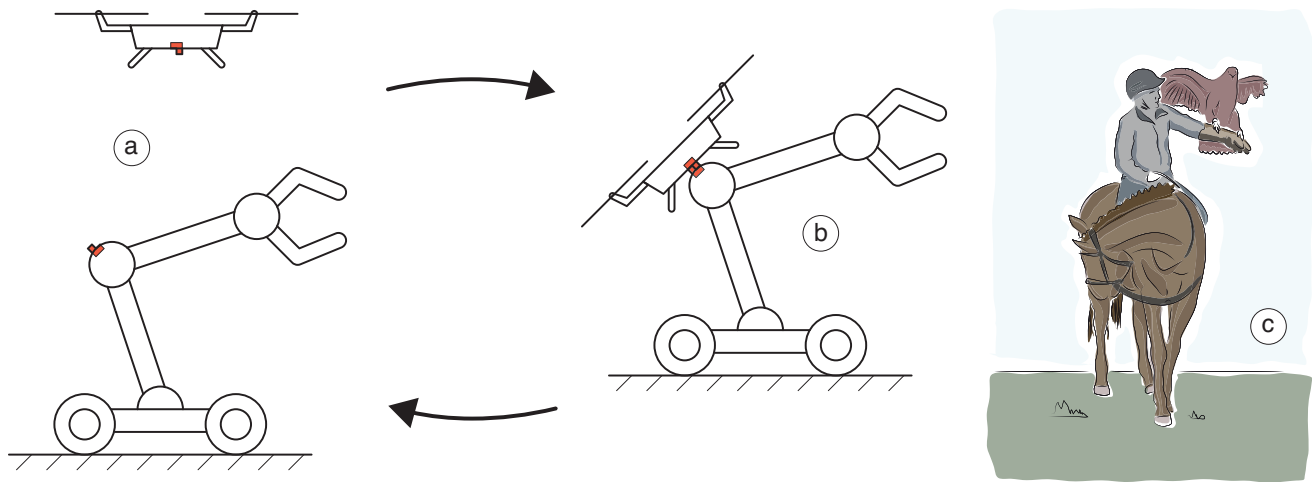

Figure 2: Collaborative flying-ground robots operating in two interchangeable phases: physically disconnected (a); connected using PCI (b). Metaphor of horseback falconry (inspired by Piper 2018 [26]) (c).

withstand countless connection cycles, and an inductive metal used for the connection surface, transmitting both signal and electricity for power charging. The two parts are identical and interchangeable, enabling the two devices to connect and disconnect easily and autonomously. This mechanism is designed to be standard and universal, can be attached to all kinds of devices and equipment, and should employ a universal communication protocol between devices. An example is the TCP/IP protocol applied by industrial robots [48, 49]. This protocol is designed to transfer information both over wire and wirelessly. Information may include position, velocity, acceleration, and current and voltage of the robots. This common physical interface provides the proposed system with flexibility, leading to possibilities for various extensions and connectivity with future devices, and could even be retrofitted to older devices. For instance, a drone could land on any kinds of ground robot, while a ground robot could receive drones of different sizes in different scenarios and settings.

With the universal PCI (indicated in red in Figure 2; details shown in Figure 3), we propose a complementary system that combines the advantages of both ground and flying robots while compensating for each ones' disadvantages. As illustrated in Figure 2, a ground robot (in this example, a mechanical arm on wheels, but it could be a variety of other primitives) is paired with a drone, and they can operate in two interchangeable phases. In Phase 1, the ground robot and the drone operate separately; they are connected over the network but physically disconnected. They can either focus on different tasks or cooperate with the same mission. In Phase 2, the ground robot is physically connected to the drone, so they can operate as a whole unit. In this phase, the drone can be charged via the port and share any data which is too massive or sensitive to be transmitted wirelessly. In both phases, the two robots can share sensor data and be commanded to work either separately or collectively, thus the whole system is smarter and more versatile than each device on its own. A good metaphor for the proposed

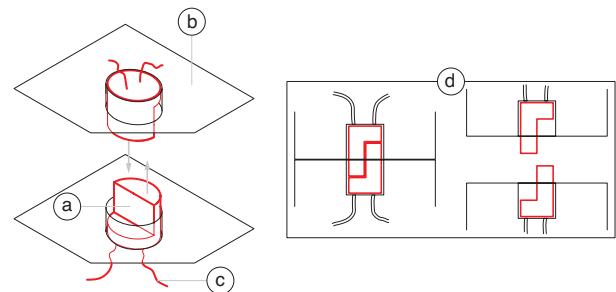

Figure 3: The proposed Physical Coupling Interface (PCI) consists of a coupler (a), device surface (b), and power-and-control wires (c). The PCI can be connected or disconnected (d).

collaborative system is a falcon commanded by a falconer on horseback (see Figure 2(c)). As shown in Figure 2, the drone is likened to the falcon, and the robot arm on wheels to the falconer on a horse. Both are mobile but work together, the falcon can follow the rider even if they move around, and it won't get lost. The combination of the horse and the rider is yet another collaborative system.

Our work is novel in the following aspects, as we propose: (i) an easy and simple coupling interface for collaborative flying-ground robots, which may be better than the existing solutions that use tethered or complex interfaces; (ii) a universal PCI may allow innumerable combinations of multiple devices and even enable these combinations to be flexibly transformed, thus creating a great potential for new diverse applications (see Figure 1). In addition to the above, (iii) we consider how the collaborative system would interact with humans under different scenarios.

4 POTENTIAL SCENARIOS OF APPLICATION

We studied some robotic applications for various scenarios, such as: remote field works [12, 14] and rescue missions [8, 18, 24, 32], transportation [27], healthcare [13, 40, 45, 47, 55], and education [4, 20, 22, 39], where our proposed system may be of value. As our concept may open such an interesting range of possibilities, we believe it will be inspiring for future researchers to further develop such systems.

4.1 Remote field works and rescue missions

People carrying out remote field work, such as mining [12], surveying, research in the desert or Antarctica or even on the moon [14], may find our system appealing. These professionals usually withstand extreme environments, severe weather, and isolation. The ground robot could include various kinds of equipment fitted with the universal physical coupling interface, paired with autonomous drones, sensors, and other devices. The system would increase a field worker's capabilities, such as taking over dangerous rescue tasks in areas otherwise too unsafe to enter. They may also be good companions in the field. Similarly, these characteristics could be also very useful for rescue missions [18, 28, 30], by allowing them to examine the unsafe areas and provide temporary emergency communication support [5] and so forth. Figure 4 shows a scenario where the collaborative system assists a rescue worker by offering multiple functions. For example, while the ground robot removes heavy obstacles and the flying robot largely extends the search areas, the system provides the human worker both with overview and focus. The rescue worker may give commands to the robots to perform diverse tasks. This is a future research field for emergency services, the military, etc.

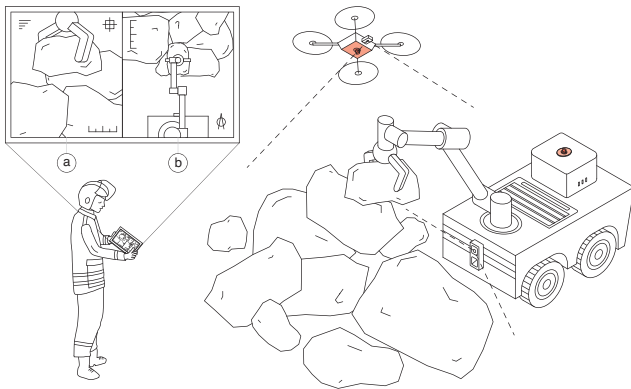

Figure 4: Collaborative system with PCI applied for a rescue mission. The monitor of the rescue worker shows both the focused view from the ground robot (a), and the overlooking view provided by the flying robot (b).

4.2 Transportation

The proposed system has great potential for use on the road. In this case, the vehicle is set to have autonomous features and is thus considered a robot by definition [15], and the physical interface is located somewhere inside the driver's cab. The autonomous

drone is by default physically connected to the vehicle inside of the cab. However, if the driver runs into bad weather or traffic jams, the drone can fly out and report back with a bird's eye view of conditions ahead and give feedback to the driver. The drone can also fly out to carry out thorough inspections around large vehicles such as lorries (Figure 5) to guarantee travel safety. In addition to these functions, the system, especially the drone, might take on a secondary role as a companion interacting with drivers to help alleviate boredom and loneliness on long journeys.

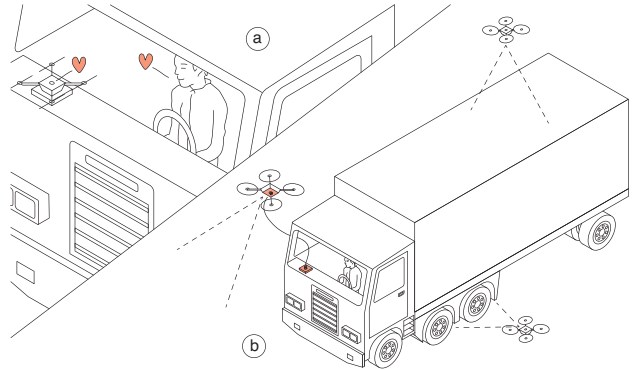

Figure 5: Collaborative system with PCI applied as a road companion: companionable interaction with the driver (a); a flying robot flies out to check road conditions and vehicle conditions (b).

4.3 Healthcare

As a greater percentage of the population is aging resulting in a shortage of young caregivers, while at the same time facing wide-scale health crises, healthcare services are under more pressure than ever before. There exists great potential to meet some of these demands using robots to supplement or replace the human workforce. In some cases, robots may even offer an advantage over humans, for example by reducing the risk of spreading an infection among healthcare workers and patients, or by providing reliable support services during periods of unstable employment. While meeting the aims of humanitarian activity, robots can also help fight the on-going pandemics [45, 47, 55].

The complementary robot system could be applied as a personal assistant for people in need, as shown in Figure 6, such as older adults, those with chronic illness, children, and even infants. The autonomous drone allied with the ground robot can help to overcome three problems: (i) reducing reaction time when an emergency happens, reaching people faster when needed, (ii) providing the bird's eye view that is important for fall detection [16], (iii) ignoring ground obstacles, as the drone can easily move around people, change the angle of view and improve the accuracy of remote diagnosis [2]. The robotic assistant could also follow users while monitoring their condition, for instance measuring their temperature, breath, heartbeats, and so forth; scan the environment to find and retrieve high or far away objects, and safeguard users and call for help if they get into trouble. Additionally, the system may also

behave like an animal companion, offering comfort to help users relax and support their mental health.

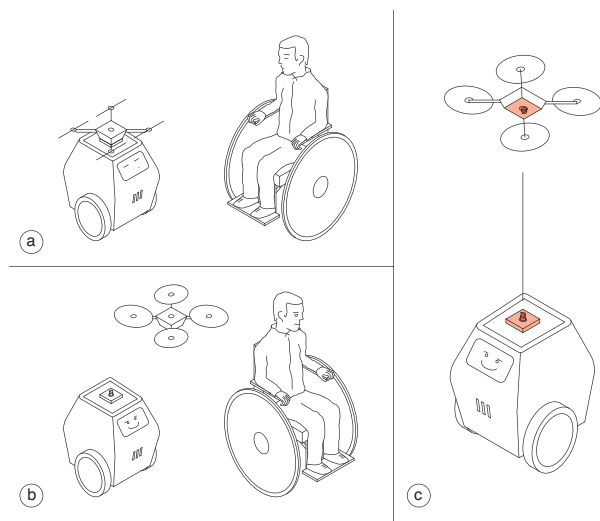

Figure 6: Collaborative system with PCI applied as personal healthcare assistant: the ground and flying robots operate as physically connected (a) or physically disconnected (b); red areas indicate the PCI (c).

Another potential application may be to integrate a drone into a prosthetic limb. A very similar concept already exists, namely a prosthetic arm which has a USB port for charging drones [13]. However, this existing concept does not count the prosthetic arm and the drone as a complementary system – the drone does not extend the capabilities of the prosthetics and is used only for gaming. We think a drone that coupled with a prosthetic limb could be more than a toy - for example, it could fly away to fetch or manipulate objects out of reach. This could extend the functionality of prosthetics and enhance the capability of the human body in new ways. This leads to some ethical and even philosophical questions, which we will take up in the discussion (see the 4th paragraph in section 5).

4.4 Education

Robotic systems have been used in education in various ways [4, 20, 22, 39, 43]. We consider the proposed system would be a useful and powerful tool for novel educational uses. The two interchangeable phases of a flying drone and a grounded base could be used to create a system to demonstrate concepts to children in a tangible way, such as models from physics, chemistry, mathematics, biology, etc. For instance, in physics, as shown in Figure 7, the autonomous drone could play the part of the electrons of an atom, and the ground robot the nucleus, so the drone could orbit around the ground robot to demonstrate the atomic structure. The ground robot could contain a projector to add further visual effects and information about the subject. A system such as this could provide teachers with multiple modalities of describing concepts, which could help in the instruction of students with different kinds of learning needs. Visual and tangible interaction creates possibilities for students to learn in

a lively and intuitive, vivid and three-dimensional fashion. While a considerable body of research exists within HCI for interaction and education, further study of the interaction between the system and its users, in this case both teachers and students, is required in order to better develop this educational tool.

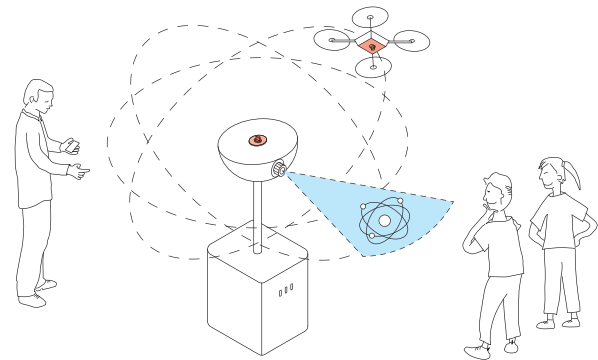

Figure 7: Collaborative system with PCI applied as an educational tool: the teacher can demonstrate atomic structure and orbits to students with multiple modalities.

5 DISCUSSION AND FUTURE WORK

The four scenarios presented here demonstrate features and benefits across different embodiments of the proposed system. The collaborative system of flying-ground robots with the modular and scalable physical coupling interface (PCI), is a significant advancement of past works, and takes advantage of the capabilities of both ground robot and drone in an easier way, so that the system can better obtain the capability of managing a larger and 3-dimensional workspace, respond with speed and agility to emergencies, and preserve its durability to maintain working frequencies.

The universal PCI enables a variety of combinations of flying and ground robots with potential benefits for a range of scenarios. Moreover, the universal PCI may be integrated into other primitives, allowing an enormous number of potential collaborative systems (see example in Figure 1), which may be studied in the future. Unexpected benefits may be possible upon further study, for example the physical connection between devices could help keep data private, as transfer of confidential data directly between devices, rather than over the internet, is less vulnerable to data breaches.

As the system interacts with humans, pet-like behaviors may also enhance how people perceive them as companions rather than cold machines. Users might find the system more comfortable and enjoyable if it can easily blend into society. However, this raises some ethical questions: is it ethical to manipulate humans' perceptions by integrating pet-like behaviors into the robots? Could this be seen as a kind of deceit, and furthermore, is it an appropriate response to social isolation? Despite these worries, Sharkey et Sharkey suggested that robot pets might improve users' lives if used carefully [41].

There is currently a lack of guidelines explicitly addressing ethical, legal and societal implications in the development of wearable

robots [19]. Ethical considerations come into play when modifying or adding to the human body. For example, the drone coupling with a prosthetic limb raises questions about how we perceive and interact with such a system once it becomes part of a person with disability. That is, the user experience of this system will depend on whether the drone is in use. When the drone flies the weight of the prosthesis is lower. When the drone hits an object at a far distance, the user may experience a collision stimulus or even pain. What could be the implications of such unprecedented technology? Should we really encourage modifying human capabilities in the sense that they need enhancement to be more “useful”? And what of enhancing perfectly abled bodies? Such questions remain to be addressed.

Besides, there are significant technical challenges to develop such systems. Not only do the mechanical components and electronics need to be designed and realized, but the algorithms and controlling solutions must also be well considered and validated, especially when two or more robots are coupled as a unit. Moreover, introducing a physical interface between devices will increase the overall cost, and each individual device itself will become more expensive.

We believe the diversity of the challenges proposed and discussed here suggest an exciting path of future research, where our concept needs to be prototyped and empirically validated under the various application scenarios listed above. The development of collaborative systems with PCI can lead to a wealth of new knowledge in both engineering and human-robot interaction.

ACKNOWLEDGMENTS

We thank all anonymous reviewers who provided valuable feedback for us to improve this work. We acknowledge the Wallenberg AI, Autonomous Systems and Software Program – Humanities and Society (WASP-HS), and this Late-Breaking Work research is funded by the Marianne and Marcus Wallenberg Foundation. This research is partially funded by MediaFutures partners and the Research Council of Norway (grant number 309339).

REFERENCES

- [1] Parastoo Abtahi, David Y. Zhao, Jane L. E., and James A. Landay. 2017. Drone Near Me: Exploring Touch-Based Human-Drone Interaction. *Proc. ACM Interact. Mob. Wearable Ubiquitous Technol.* 1, 3, Article 34 (sep 2017), 8 pages. <https://doi.org/10.1145/3130899>
- [2] Michael Baer, Marie-Ange Tilliette, Alexandre Jeleff, Anna Ozguler, and Thomas Loeb. 2014. Assisting older people: from robots to drones. *Gerontechnology* 13, 1 (2014), 57–58.
- [3] Eamon Barrett, Mark Reiling, Seyedmohsen Mirhassani, René Meijering, Jeroen Jager, Nicola Mimmo, Flavio Callegati, Lorenzo Marconi, Raffaella Carloni, and Stefano Stramigioli. 2018. Autonomous battery exchange of UAVs with a mobile ground base. In *2018 IEEE International Conference on Robotics and Automation (ICRA)*. IEEE, 699–705.
- [4] Aurelio Bermúdez, Rafael Casado, Guillermo Fernández, María Guijarro, and Pablo Olivas. 2019. Drone challenge: A platform for promoting programming and robotics skills in K-12 education. *International Journal of Advanced Robotic Systems* 16, 1 (2019), 1729881418820425. <https://doi.org/10.1177/1729881418820425> arXiv:<https://doi.org/10.1177/1729881418820425>
- [5] Irem Bor-Yaliniz and Halim Yanikomeroglu. 2016. The new frontier in RAN heterogeneity: Multi-tier drone-cells. *IEEE Communications Magazine* 54, 11 (2016), 48–55.
- [6] Mohamed Nadir Boukoberine, Zhibin Zhou, and Mohamed Benbouzid. 2019. A critical review on unmanned aerial vehicles power supply and energy management: Solutions, strategies, and prospects. *Applied Energy* 255 (2019), 113823.
- [7] Mohamed Nadir Boukoberine, Zhibin Zhou, and Mohamed Benbouzid. 2019. Power supply architectures for drones-a review. In *IECON 2019-45th Annual Conference of the IEEE Industrial Electronics Society*, Vol. 1. IEEE, 5826–5831.
- [8] SJ Corfield and JM Young. 2006. Unmanned surface vehicles-game changing technology for naval operations. *IEE Control Engineering Series* 69 (2006), 311.
- [9] FOTOKITE. 2022. *Built for First Responders*. Retrieved January 3, 2022 from <https://fotokite.com/>
- [10] Katsuya Fujii, Keita Higuchi, and Jun Rekimoto. 2013. Endless Flyer: A Continuous Flying Drone with Automatic Battery Replacement. In *2013 IEEE 10th International Conference on Ubiquitous Intelligence and Computing and 2013 IEEE 10th International Conference on Automatic and Trusted Computing*. 216–223. <https://doi.org/10.1109/UIC-ATC.2013.103>
- [11] Fully charged show (Youtube) 2020. *NIO ES8 & 3-minute Battery Swap Station / FULLY CHARGED for Clean Energy & Electric Vehicles*. Retrieved January 3, 2022 from <https://www.youtube.com/watch?v=hTsrDpsYHrw>
- [12] Sungsik Huh, Unghui Lee, Hyunchul Shim, Jong-Beom Park, and Jong-Ho Noh. 2011. Development of an unmanned coal mining robot and a tele-operation system. In *2011 11th International Conference on Control, Automation and Systems*. 31–35.
- [13] Ingmar Nieuweboer (Next Nature Network) 2016. *Bionic Prosthetic Arm with Personal Drone*. Retrieved January 3, 2022 from <https://nextnature.net/magazine/story/2016/prosthetic-arm-features-drone>
- [14] Wing-Huen Ip, Jun Yan, Chun-Lai Li, and Zi-Yuan Ouyang. 2014. Preface: The Chang'e-3 lander and rover mission to the Moon. *Research in Astronomy and Astrophysics* 14, 12 (2014), 1511.
- [15] ISO 8373:2021(en) 2021. *Robotics — Vocabulary*. Standard. International Organization for Standardization, Geneva, CH.
- [16] Cristi Iuga, Paul Drăgan, and Lucian Buşoni. 2018. Fall monitoring and detection for at-risk persons using a UAV. *IFAC-PapersOnLine* 51, 10 (2018), 199–204.
- [17] N. Jazdi. 2014. Cyber physical systems in the context of Industry 4.0. In *2014 IEEE International Conference on Automation, Quality and Testing, Robotics*. 1–4. <https://doi.org/10.1109/AQTR.2014.6857843>
- [18] Jeremiah Karpowicz (Commercial UAV News) 2018. *4 Ways Drones are Being Used in Maritime and Offshore Services*. Retrieved January 3, 2022 from <https://www.commercialuavnews.com/security/4-ways-drones-maritime-offshore-services>
- [19] Alexandra Kapeller, Heike Felzmann, Eduard Fosch-Villaronga, Kostas Nizamis, and Ann-Marie Hughes. 2021. Implementing Ethical, Legal, and Societal Considerations in Wearable Robot Design. *Applied Sciences* 11, 15 (2021), 6705.
- [20] Ameen Kazerouni, Brandon Shrewsbury, and Cliff Padgett. 2011. Using the NXT as an Educational Tool in Computer Science Classes. In *Proceedings of the 49th Annual Southeast Regional Conference (Kennesaw, Georgia) (ACM-SE '11)*. Association for Computing Machinery, New York, NY, USA, 67–69. <https://doi.org/10.1145/2016039.2016063>
- [21] Seiga Kiribayashi, Jun Ashizawa, and Keiji Nagatani. 2015. Modeling and design of tether powered multicopter. In *2015 IEEE International Symposium on Safety, Security, and Rescue Robotics (SSRR)*. IEEE, 1–7.
- [22] Tomáš Krajník, Vojtěch Vonásek, Daniel Fišer, and Jan Faigl. 2011. AR-Drone as a Platform for Robotic Research and Education. In *Research and Education in Robotics - EUROBOT 2011*. Achim Gottscheber David Obdržálek (Ed.). Springer Science & Business Media, Prague, Czech Republic, 172–186. https://doi.org/10.1007/978-3-642-21975-7_16
- [23] Sang-won Leigh and Pattie Maes. 2016. Body integrated programmable joints interface. In *Proceedings of the 2016 CHI Conference on Human Factors in Computing Systems*. 6053–6057.
- [24] Vincenzo Lomonaco, Angelo Trotta, Marta Ziosi, Juan De Dios Yáñez Avila, and Natalia Díaz-Rodríguez. 2018. Intelligent drone swarm for search and rescue operations at sea. arXiv:1811.05291
- [25] Teng Long, Mustafa Ozger, Oktay Cetinkaya, and Ozgur B Akan. 2018. Energy neutral internet of drones. *IEEE Communications Magazine* 56, 1 (2018), 22–28.
- [26] Lucy Piper. 2018. *Caymans the horse, Floki the eagle, and me toward the end of my lesson at Dartmoor Hawking*. Retrieved January 11, 2022 from <https://www.atlasobscura.com/articles/horseback-falconry-lesson>
- [27] Wenbo Ma, Shishu Zhao, She Xu, Kuiyuan Guo, and Kongjian Qin. 2021. Research on application of automatic driving main-routes logistics in China. In *International Conference on Smart Transportation and City Engineering 2021*, Vol. 12050. SPIE, 591–598.
- [28] Lorenzo Marconi, Claudio Melchiorri, Michael Beetz, Dejan Pangercic, Roland Siegwart, Stefan Leutenegger, Raffaella Carloni, Stefano Stramigioli, Herman Bruyninckx, Patrick Doherty, et al. 2012. The SHERPA project: Smart collaboration between humans and ground-aerial robots for improving rescuing activities in alpine environments. In *2012 IEEE International Symposium on Safety, Security, and Rescue Robotics (SSRR)*. IEEE, 1–4.
- [29] Nobutaka Matsushima, Wataru Yamada, and Hiroyuki Manabe. 2017. Attaching Objects to Smartphones Back Side for a Modular Interface. In *Adjunct Publication of the 30th Annual ACM Symposium on User Interface Software and Technology (Québec City, QC, Canada) (UIST '17)*. Association for Computing Machinery, New York, NY, USA, 51–52. <https://doi.org/10.1145/3131785.3131810>
- [30] Takahiro Miki, Petr Khrapchenkov, and Koichi Hori. 2019. UAV/UGV autonomous cooperation: UAV assists UGV to climb a cliff by attaching a tether. In *2019 International Conference on Robotics and Automation (ICRA)*. IEEE, 8041–8047.

- [31] Prince K. Nana. 2007. Detachable back-up battery pack for cell phone. Patent No. US7619388B1, Filed March 5th., 2007, Issued Nov. 17th., 2009.
- [32] Mamta Narang, William Liu, Jairo Gutierrez, and Luca Chiaraviglio. 2017. A cyber physical buses-and-drones mobile edge infrastructure for large scale disaster emergency communications. In *2017 IEEE 37th International Conference on Distributed Computing Systems Workshops (ICDCSW)*. IEEE, 53–60.
- [33] Eduardo Narváez, Ankit A. Ravankar, Abhijeet Ravankar, Takanori Emaru, and Yukinori Kobayashi. 2021. Autonomous VTOL-UAV Docking System for Heterogeneous Multirobot Team. *IEEE Transactions on Instrumentation and Measurement* 70 (2021), 1–18. <https://doi.org/10.1109/TIM.2020.3039649>
- [34] Mohammad Obaid, Wafa Johal, and Omar Mubin. 2020. Domestic Drones: Context of Use in Research Literature. In *Proceedings of the 8th International Conference on Human-Agent Interaction (Virtual Event, USA) (HAI '20)*. Association for Computing Machinery, New York, NY, USA, 196–203. <https://doi.org/10.1145/3406499.3415076>
- [35] Oculus (Youtube) 2020. *Infinite Office*. Retrieved January 3, 2022 from https://www.youtube.com/watch?v=5_bvkbG1ZCo
- [36] Christos Papachristos and Anthony Tzes. 2014. The power-tethered UAV-UGV team: A collaborative strategy for navigation in partially-mapped environments. In *22nd Mediterranean Conference on Control and Automation*. IEEE, 1153–1158.
- [37] Rajeev Piyare. 2013. Internet of Things: Ubiquitous Home Control and Monitoring System using Android based Smart Phone. *International Journal of Internet of Things* 2 (09 2013), 5–11. <https://doi.org/10.5923/j.ijit.20130201.02>
- [38] Andreas Plageras, Kostas Psannis, Yutaka Ishibashi, and Byung-Gyu Kim. 2016. IoT-based Surveillance System for Ubiquitous Healthcare. <https://doi.org/10.1109/IECON.2016.7793281>
- [39] Pedro Plaza, Elio Sancristobal, German Fernandez, Manuel Castro, and Clara Pérez. 2016. Collaborative robotic educational tool based on programmable logic and Arduino. In *2016 Technologies Applied to Electronics Teaching (TAEE)*. 1–8. <https://doi.org/10.1109/TAEE.2016.7528380>
- [40] Roberto Saracco (IEEE Future Directions) 2019. *Autonomous systems in healthcare*. Retrieved January 3, 2022 from <https://cmte.ieee.org/futuredirections/2019/07/21/autonomous-systems-in-healthcare/>
- [41] Amanda Sharkey and Noel Sharkey. 2012. Granny and the robots: ethical issues in robot care for the elderly. *Ethics and information technology* 14, 1 (2012), 27–40.
- [42] Manuel Silverio-Fernández, Suresh Renukappa, and Subashini Suresh. 2018. What is a smart device? - A conceptualisation within the paradigm of the internet of things. *Visualization in Engineering* 6, 1 (2018), 1–10.
- [43] Patricia Smith, Vanessa Sefton, and Lorraine Chaffer. 2015. *Geography Bulletin* 47, 2 (2015), 25–34. <https://search.informit.org/doi/10.3316/informit.433537472680270>
- [44] Haodan Tan, Jangwon Lee, and Gege Gao. 2018. Human-Drone Interaction: Drone Delivery & Services for Social Events. In *Proceedings of the 2018 ACM Conference Companion Publication on Designing Interactive Systems (Hong Kong, China) (DIS '18 Companion)*. Association for Computing Machinery, New York, NY, USA, 183–187. <https://doi.org/10.1145/3197391.3205433>
- [45] Mahdi Tavakoli, Jay Carriere, and Ali Torabi. 2020. Robotics, Smart Wearable Technologies, and Autonomous Intelligent Systems for Healthcare During the COVID-19 Pandemic: An Analysis of the State of the Art and Future Vision. *Advanced Intelligent Systems* 2, 7 (2020), 2000071. <https://doi.org/10.1002/aisy.202000071> arXiv:<https://onlinelibrary.wiley.com/doi/pdf/10.1002/aisy.202000071>
- [46] Amit Kumar Tyagi, Sonam Sharma, Nandula Anuradh, N Sreenath, et al. 2019. How a User will Look the Connections of Internet of Things Devices?: A Smarter Look of Smarter Environment. In *Proceedings of 2nd International Conference on Advanced Computing and Software Engineering (ICACSE)*.
- [47] UNICEF 2020. *Rapid Guidance: How Drones Can Be Used to combat COVID-19*. Retrieved January 3, 2022 from <https://www.unicef.org/supply/media/5286/file/%20Rapid-guidance-how-can-drones-help-in-COVID-19-response.pdf>
- [48] Universal Robots Support 2020. *REAL-TIME DATA EXCHANGE (RTDE) GUIDE*. Retrieved March 3, 2022 from <https://www.universal-robots.com/articles/ur/interface-communication/real-time-data-exchange-rtde-guide/>
- [49] Universal Robots Support 2020. *REMOTE CONTROL VIA TCP/IP*. Retrieved March 3, 2022 from <https://www.universal-robots.com/articles/ur/interface-communication/remote-control-via-tcpip/>
- [50] N Kemal Ure, Girish Chowdhary, Tuna Toksoz, Jonathan P How, Matthew A Vavrina, and John Vian. 2014. An automated battery management system to enable persistent missions with multiple aerial vehicles. *IEEE/ASME transactions on mechatronics* 20, 1 (2014), 275–286.
- [51] Pramod Verma. 2019. Stick User Interface (UIST '19). Association for Computing Machinery, New York, NY, USA, 60–62. <https://doi.org/10.1145/3332167.3357115>
- [52] Katrin Wolf. 2013. Ubiquitous Grasp Interfaces (TEI '13). Association for Computing Machinery, New York, NY, USA, 377–378. <https://doi.org/10.1145/2460625.2460702>
- [53] Chungki Woo, Sanha Kang, Hojin Ko, Hochan Song, and Jae Ook Kwon. 2017. Auto charging platform and algorithms for long-distance flight of drones. In *2017 IEEE International Conference on Consumer Electronics (ICCE)*. 186–187. <https://doi.org/10.1109/ICCE.2017.7889280>
- [54] Xuesu Xiao, Jan Dufek, and Robin Murphy. 2019. Benchmarking Tether-based UAV Motion Primitives. 51–55. <https://doi.org/10.1109/SSRR.2019.8848946>
- [55] Boo-Ho Yang and Sokwoo Rhee. 2000. Development of the ring sensor for healthcare automation. *Robotics and Autonomous Systems* 30 (02 2000), 273–281. [https://doi.org/10.1016/S0921-8890\(99\)00092-5](https://doi.org/10.1016/S0921-8890(99)00092-5)
- [56] Xuanxia Yao, Fadi Farha, Rongyang Li, Ismini Psychoula, Liming Chen, and Huansheng Ning. 2021. Security and privacy issues of physical objects in the IoT: Challenges and opportunities. *Digital Communications and Networks* 7, 3 (2021), 373–384. <https://doi.org/10.1016/j.dcan.2020.09.001>