



**CHALMERS**  
UNIVERSITY OF TECHNOLOGY

## **A techno-economic assessment of CO<sub>2</sub> capture in biomass and waste-fired combined heat and power plants – A Swedish case study**

Downloaded from: <https://research.chalmers.se>, 2026-04-03 07:18 UTC

Citation for the original published paper (version of record):

Beiron, J., Normann, F., Johnsson, F. (2022). A techno-economic assessment of CO<sub>2</sub> capture in biomass and waste-fired combined heat and power plants – A Swedish case study. *International Journal of Greenhouse Gas Control*, 118. <http://dx.doi.org/10.1016/j.ijggc.2022.103684>

N.B. When citing this work, cite the original published paper.

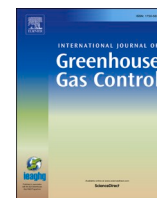

# A techno-economic assessment of CO<sub>2</sub> capture in biomass and waste-fired combined heat and power plants – A Swedish case study

Johanna Beiron<sup>\*</sup>, Fredrik Normann, Filip Johnsson

Department of Space, Earth and Environment, Chalmers University of Technology, S-412 96 Göteborg, Sweden

## ARTICLE INFO

### Keywords:

CCS  
Negative emissions  
District heating  
Combined heat and power  
Heat integration

## ABSTRACT

The need to reduce global CO<sub>2</sub> emissions is urgent and might be facilitated by carbon capture and storage (CCS) technologies. Sweden has a goal to reach net-zero emissions by 2045. Negative emissions and bio-CCS (BECCS) have been proposed as important strategies to reach this target at the lowest cost. The Swedish district heating sector constitutes a large potential for BECCS, with biogenic point sources of CO<sub>2</sub> in the form of combined heat and power (CHP) plants that burn biomass residues from the forest industry. This study analyzes the potential of CO<sub>2</sub> capture in 110 existing Swedish biomass or waste-fired CHP plants. Process models of CHP steam cycles give the impacts of absorption-based CCS on heat and electricity production, while a district heating system unit commitment model gives the impact on plant operation and the potential for CO<sub>2</sub> capture. The results provide a cost for carbon capture and transport to the nearest harbor by truck: up to 19.3 MtCO<sub>2</sub>/year could be captured at a cost in the range of 45–125 €/tCO<sub>2</sub>, corresponding to around 40% of the total fossil fuel-based Swedish CO<sub>2</sub> emissions. This would be sufficient to meet a proposed target of 3–10 Mt/year of BECCS by 2045.

## 1. Introduction

Climate change, caused by anthropogenic emissions of CO<sub>2</sub>, requires urgent actions to limit the impacts of global warming. Carbon capture and storage (CCS) has been identified as an important component of the strategy to meet long-term CO<sub>2</sub> emission targets which, to comply with the Paris Agreement regarding the limiting of global warming to “well-below” 2°C, will most likely require that global carbon emissions are net-zero by around year 2050. After this, emissions have to become net-negative (IPCC, 2018), as there is a high likelihood of an overshoot in the emission trajectory. If applying CCS to biogenic emission sources (BECCS) and assuming these processes are using biomass from biomass systems with a net growth in carbon stock, so-called “negative emissions” could be achieved. These can serve two purposes: (i) to offset residual emissions that are hard-to-abate, in order to reach net-zero emissions; and (ii) in the longer run, to obtain net-negative emissions. Compared to other negative-emissions technologies, BECCS is proposed to be the most mature option in terms of technology (Kemper, 2015).

Sweden has a goal to reach net-zero emissions by 2045. Negative emissions – and BECCS in particular – have been identified as important possibilities to reach this target at the lowest cost. A public inquiry in Sweden (SOU, 2020) has proposed that the contribution from BECCS

should reach up to 2 MtCO<sub>2</sub>/year in 2030 and 3–10 MtCO<sub>2</sub>/year by 2045, with the wide ranges reflecting uncertainties as to how much other measures will contribute to the net-zero target in 2045. The upper bound on the proposed contribution from BECCS of 10 MtCO<sub>2</sub> captured/year correspond to around 20% of Sweden’s current total greenhouse gas emissions from all sectors (52 MtCO<sub>2eq</sub>/year) and around 25% of the total CO<sub>2</sub> emissions (43 MtCO<sub>2</sub>/year). There are many large point sources of biogenic CO<sub>2</sub> emissions in the Swedish energy and industry sectors, entailing a substantial potential for CCS applications (Fuss and Johnsson, 2021; Johnsson et al., 2020; Kouri et al., 2017). Johnsson et al. (2020) have shown that applying CCS to the largest industrial emission sources (with yearly CO<sub>2</sub> emissions >500 kt/year) can capture 23 MtCO<sub>2</sub>/year at a cost in the range of 80–140 €/tCO<sub>2</sub>.

In addition to industrial sources, there are many combined heat and power (CHP) plants operating in the heat sector that combust biomass or municipal solid waste that is partly of biogenic origin. Implementation of BECCS at CHP plants could contribute to reaching the above-mentioned BECCS target, and it might also present a business case for the plants if financial compensation is granted for negative emissions (Kärki et al., 2017). Even though economic incentives are currently lacking, BECCS, for example, is being considered for the district heating (DH) system in Stockholm (Leviñ et al., 2019), and it has been studied for the Helsinki DH network (Tsupari et al., 2017). Thus, once the

<sup>\*</sup> Corresponding author at: Department of Space, Earth and Environment, Chalmers University of Technology, S-412 96 Göteborg, Sweden.

E-mail address: [beiron@chalmers.se](mailto:beiron@chalmers.se) (J. Beiron).

<https://doi.org/10.1016/j.ijggc.2022.103684>

Received 5 September 2021; Received in revised form 22 April 2022; Accepted 27 April 2022

Available online 3 May 2022

1750-5836/© 2022 The Authors. Published by Elsevier Ltd. This is an open access article under the CC BY license (<http://creativecommons.org/licenses/by/4.0/>).

### Nomenclature

BECCS	bio-energy carbon capture and storage
CAPEX	capital expenditures
CCS	carbon capture and storage
CHP	combined heat and power
CO <sub>2</sub>	carbon dioxide
COP	coefficient of performance
DH	district heating
FGC	flue gas condenser
HOB	heat-only boiler
HPFWH	high-pressure feedwater preheater
LHV	lower heating value
LPFWH	low-pressure feedwater preheater
MEA	monoethanolamine
OPEX	operational expenditures

economic incentives are in place, it should be possible to establish full-scale projects within a few years, as the post-combustion carbon capture technology can be seen as commercially available. The Stockholm utility company Stockholm Exergi targets year 2025 for full-scale implementation of CCS in their newest biomass-fired CHP plant. In the abovementioned public inquiry, it was proposed to establish a reversed governmental auctioning system to finance the ramping up of BECCS to meet the 2030 target. In addition to policy-driven incentives, there is an emerging voluntary market for negative emissions, whereby several companies have declared that they will offset their emissions, in some cases also including historical emissions, as announced by Microsoft (Smith, 2020). BECCS should be attractive for such a compensation program, owing to the high permeance of the CO<sub>2</sub> removal (i.e., long-term carbon storage of 100-1000 years).

In previous studies, the global potential for municipal solid waste to contribute to BECCS has been estimated (Pour et al., 2018), along with a techno-economic screening of biomass-based power generation with BECCS (Bhave et al., 2017). Magnanelli et al. (2021) studied options for the design and operation of carbon capture integrated in a waste-to-energy plant. The energy penalty of hot potassium carbonate capture technology applied to a biomass-fired CHP plant was quantified (Gustafsson et al., 2021). However, there are few previous studies on BECCS applied specifically to CHP plants or the implications for DH systems of retrofitting CHP plants with CCS.

A particular challenge for applying BECCS at CHP plants is that they have fewer full-load hours than large coal-fired, base-load power plants and industrial units, the exception being waste-fired CHP plants, which typically have a high number of full-load hours. This will cause the investment cost to be allocated to a lower number of hours, thereby driving up the capture cost. As CHP plants are also typically smaller in size than power plants, this also increases the specific capture cost due to a lower economy of scale for both the capture and transport logistics. Despite the favorable conditions for BECCS in the Swedish DH system, the cost range for capture in the available plants, considering the size range of the CHP plants and their operational characteristics, is not known.

This work provides a techno-economic assessment of absorption-based CO<sub>2</sub> capture in Swedish CHP plants, with respect to the carbon capture potential, plant performance and utilization, and costs. Given the conditions for CHP plants outlined above, the aim of the study is to quantify the impact of CCS on biomass and waste-fired CHP plants and DH system unit commitment, as well as the effect of plant scale and utilization on the cost of capture. For the existing capacity of Swedish CHP plants, the implementation of carbon capture is evaluated on the following three energy system levels: (i) the process level, i.e., the impact on CHP plant performance; (ii) the DH system level, i.e., the

impact on the operation of DH networks; and (iii) the national level, aggregating the carbon captured from all DH systems in Sweden for comparison with proposed national targets. In addition, the cost for carbon capture and local transport is estimated, considering scale effects and the geographic distribution of plants, and is expressed as a marginal abatement cost curve for the plants included in this work.

## 2. Method

The techno-economic assessment of and potential for CCS from CHP plants in Sweden is based on a set of models, as illustrated in Fig. 1. A process model provides the CHP steam cycle performance when driving an MEA-based CO<sub>2</sub> absorption unit, for a set of CHP plant case studies. The energy demands of the capture plant are calculated using the carbon capture plant model of Ignell and Johansson (2021). The modeled process performances are used as inputs to the DH system unit commitment model, which assesses the impact on CHP plant operating patterns of integrating carbon capture, including full-load hours and carbon capture potential. The unit commitment analysis is applied to all CHP plants in Sweden (biomass and waste-fired) in their respective local DH system contexts, based on a CHP plant database. Finally, applying the process and system model results, an estimation is made of the capital and operational expenditures of carbon capture, as well as the costs for CO<sub>2</sub> truck transport to an intermediate storage hub, in preparation for onward ship transport and final storage. Based on the cost estimates, a marginal abatement cost curve for CHP plants with CCS is developed. The following subsections describe the Swedish CHP plant portfolio, the modeling methods applied, and the economic assumptions made in relation to the cost estimations.

### 2.1. CHP plant database

The CHP plant database contains information on all the Swedish CHP plants that combust biomass or waste (110 plants in total), located in 78 geographically distributed local DH systems. The data encompass nominal CHP plant heat and electricity production capacities, flue gas condenser installations, live steam conditions and year of commissioning. Fig. 2 presents the distributions of steam cycle power-to-heat ratios, thermal capacity, and fuel type for all the plants in the database. The fuel is here divided into biomass (typically residues from the forest industry) and waste, (municipal solid waste, a certain fraction of which is fossil-based in the form of plastics). The thermal capacities of the boilers range from 7 MW to 540 MW, and the steam cycles have power-to-heat ratios in the range of 0.1–0.65. Thus, there is a wide variety of plant types with differing designs, examples of which are given in Section 2.2. Although it may seem obvious that the application of CCS in the smaller plants (with capacities down to around 10 MW included in this study) will be associated with higher costs, all the plants are included so as to assess the entire cost range for CCS. Details of the database are available in the Supplementary Material.

### 2.2. Process modeling of CHP steam cycles with carbon capture

Steady-state process models of CHP plants are developed in Epsilon Professional and simulate the impact on steam cycle performance of the integration of amine-based, post-combustion carbon capture. In total, 14 steam cycle designs with different fuel types, live steam conditions, and power-to-heat ratios are considered to represent the range of CHP plants in the database. Fig. 3 gives a schematic overview of the steam cycle designs modeled, where steam extractions A–C are optional and used to cover the range of performances of the considered plants. The included steam extractions and the corresponding pressures for each plant modeled are given in Table 1, together with the live steam temperatures and pressures. The steam turbine isentropic efficiency is set to 88%, independent of case. The boiler is represented in the model by a steam generator component, with a boiler efficiency of 90%, and with fuel

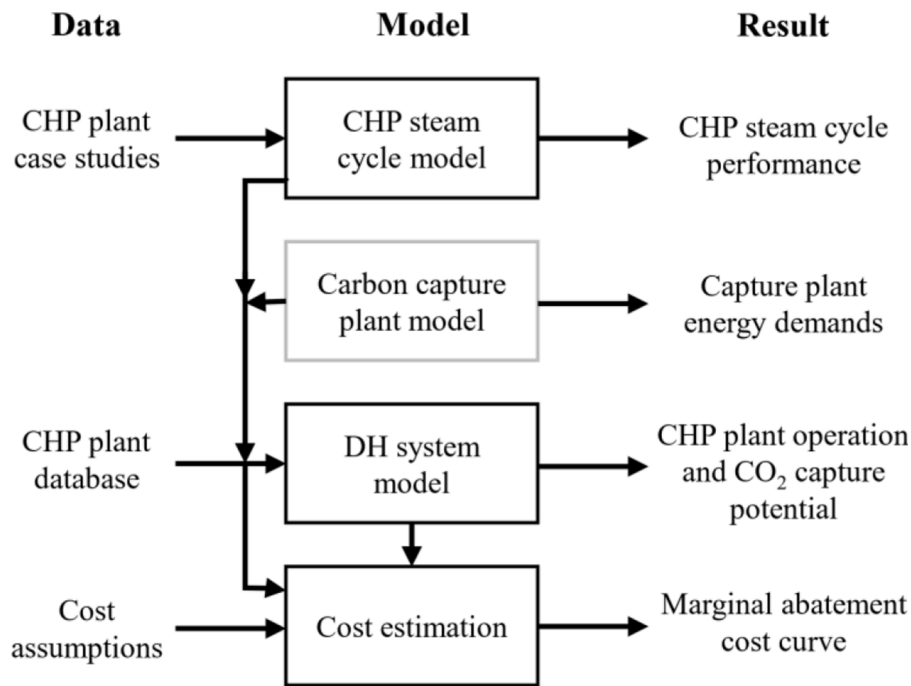

Fig. 1. Flowchart of the methods and models used, with outcomes.

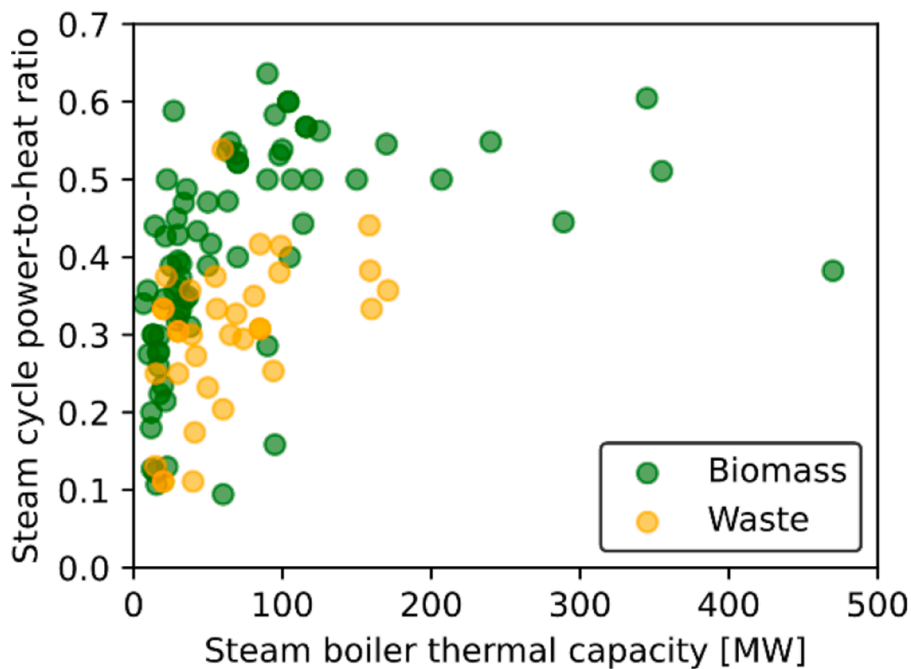
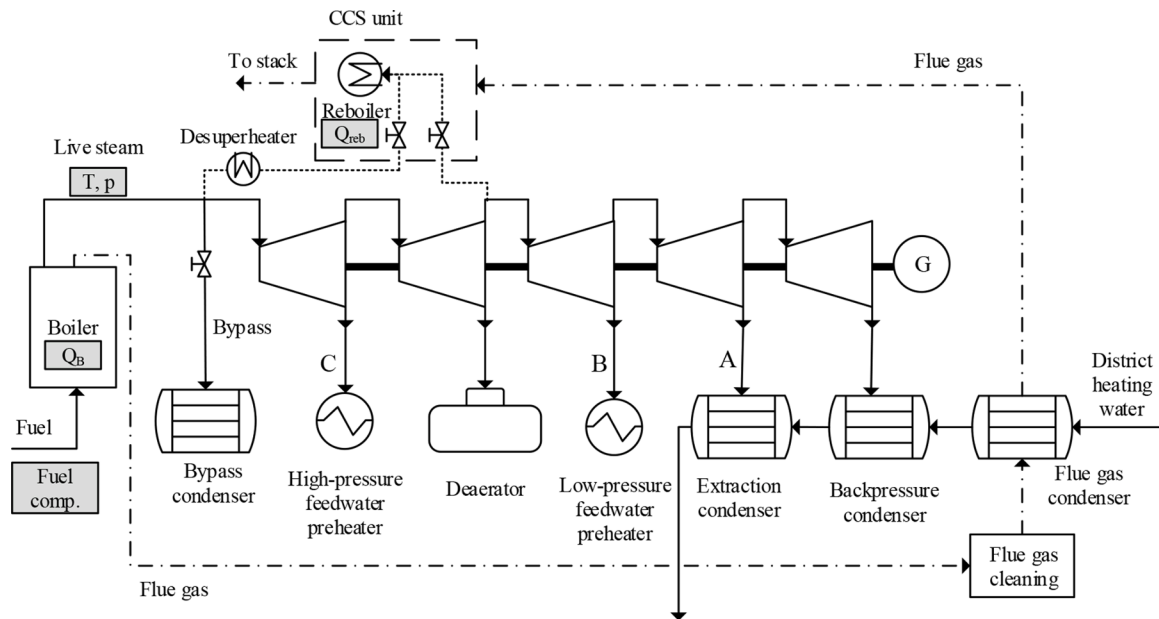

Fig. 2. Characterization of the 110 Swedish CHP plants, with respect to boiler thermal capacity, steam cycle power-to-heat ratio and fuel type. Each marker represents one plant.

composition specified according to Table 2. In practice, the fuel composition and moisture content vary depending on, for example, the biomass type, although this aspect is neglected in this study. The biogenic share of the waste is assumed to be 52% (Statistics Sweden, 2019). DH is generated in the backpressure condenser, and where applicable, also in an extraction condenser and/or a flue gas condenser. Boundary conditions for the DH water are set to 50°C for the inlet temperature to the backpressure DH condenser and 90°C for the supply temperature.

The carbon capture plant is a post-combustion, absorption-based

unit that requires heat at a temperature of 120°C for the reboiler and is represented by a heat sink in the model. A heat load of 3.6 MJ/kgCO<sub>2</sub>-captured is chosen based on the conditions for biomass or waste-fired CHP plants with 90% capture rate from a flue gas CO<sub>2</sub> concentration of 13%–15% using monoethanolamine (MEA), according to previous work (Gardarsdóttir et al., 2018). Steam is extracted from the CHP plant steam turbine at the pressure level that is most suitable to meet the reboiler heat demand, ensuring that steam at 3 bar is delivered to the reboiler. Alternatively, if no suitable turbine extraction is available, the steam for the CCS reboiler is throttled directly from the live steam flow.



**Fig. 3.** Process schematic of a CHP steam cycle. (A–C) Indicate the optional steam turbine extractions for the different process models that best represent each plant in the case studies. The notations in gray boxes indicate input data that are specified according to Table 1. Dotted lines represent steam extraction alternatives that are retrofitted to drive the carbon capture reboiler.

Prior to entering the carbon capture plant, the flue gas undergoes flue gas cleaning and is cooled in a flue gas condenser (FGC), which contributes to DH generation. At the time of the present study, 85 of the 110 plants in the database have flue gas condensers installed. An FGC is assumed to be installed at plants that are not already equipped with one, together with the retrofit of the carbon capture plant.

The steam cycle models are simulated in design mode without carbon capture as a reference case, and in off-design mode with a 90% carbon capture rate. The off-design simulation takes into account steam turbine part-load performance based on Stodola's law (Cooke, 1985) and calculates the (reduction in) turbine stage pressure when steam is extracted to the reboiler. The boiler load is kept constant in the reference and carbon capture cases, and the changes in electricity and DH outputs are simulated. In addition to electricity and DH, some plants deliver steam to industrial processes (not shown in Fig. 3), and the delivery of process heat is maintained when CCS is integrated.

### 2.3. District heating system unit commitment model

The DH system unit commitment model is a spreadsheet tool that evaluates the hourly operation of CHP plants in a local DH system. The model inputs are: an hourly heat demand profile spanning 1 year; the subset of CHP plants that are located in each DH system; and CHP plant performance data. A reference case without carbon capture is compared to cases in which all the CHP plants in the system operate with CO<sub>2</sub> capture.

#### 2.3.1. CHP plant performance with CCS and heat recovery cases

The net CHP plant performance with a 90% carbon capture rate is a combination of the impacts on steam cycle electricity and DH generation, and the electricity consumption of, and DH recovery from, the capture plant (including CO<sub>2</sub> absorption, compression and liquefaction). The steam cycle performance is obtained from the steam cycle process simulations (Section 2.2) and applied to all the CHP plants in the database. For those plants that install a new flue gas condenser as part of the capture plant retrofit, the additional FGC DH generation is assumed to be 20% of the fuel energy [Lower Heating Value (LHV) basis]. The amount of CO<sub>2</sub> captured per fuel used is obtained from the process simulations, based on the fuel compositions specified in Table 2.

The capture plant performance is based on a process model of a carbon capture plant that was developed in Aspen Plus (Ignell and Johansson, 2021), with an estimated capture plant electricity consumption of 0.1 MWh/tCO<sub>2</sub>. Heat recovery from the capture plant for DH generation is applied to all plants, and three cases with different extents of heat recovery are compared:

- No heat recovery (0%);
- Heat recovery through heat exchangers, corresponding to 64% of the energy in the steam extracted to drive the CCS reboiler (Ignell and Johansson, 2021); and
- Heat recovery corresponding to case b and additionally using heat pumps (COP = 3) to produce DH from the cooling demand (i.e., carbon capture plant process streams with temperatures <60°C that need cooling), resulting in up to 118% total heat recovery relative to the energy in the steam extracted to drive the reboiler, with a heat pump electricity consumption of 0.17 MWh/tCO<sub>2</sub>. This case is designated as "118%", although some plants may reach slightly lower total heat recovery percentages.

#### 2.3.2. District heating demand profiles

The load profiles for the yearly DH demands with hourly resolution are based on real data for three Swedish cities (Luleå, Gothenburg and Malmö; year 2012) located in different parts of the country, to account for geographic variations in air temperature levels. The demand data for Luleå and Malmö are obtained from the published database (Schweiger et al., 2017). The data for Gothenburg are obtained via personal communication with the local DH utility companies, as previously published (Romanchenko et al., 2017). The demand profile of the city that is located closest to each specific DH system is applied in the model calculations, and scaled to match the total annual delivery of DH of the respective DH network [annual demand data are obtained from (Energiföretagen Sverige, 2021)].

#### 2.3.3. DH system merit order and unit commitment model

The DH system unit commitment model is based on the operation of plants according to a predetermined merit order, as presented in Table 3, and is applied to all DH systems. The merit order represents the current operational priorities of Swedish DH networks. If a plant type is not

**Table 1**  
 Technical data for the steam cycle case studies. The letters in parentheses used to label some of the column titles (Second DH condenser, LPFWH and HPFWH) correspond to the steam turbine extractions indicated in Fig. 3.

	Plant name, City	Fuel	Design power-to-heat-ratio	Boiler thermal capacity ( $Q_B$ ) [ $MW_{th}$ ]	Primary steam temperature [ $^{\circ}C$ ]	Primary steam pressure [bar]	Second DH condenser (A)	LPFWH [bar] (B)	Deaerator pressure [bar]	HPFWH [bar] (C)	Industrial process steam	Reference
Steam cycles modeled with turbine extraction to reboiler	Idbäckverket, Nyköping	Biomass	0.57	95	543	143	Yes	3.5	8.6	29	No	(Saarinen, 2008)
	Lugnvik CHP plant, Östersund	Biomass	0.56	125	540	140	Yes	3	7.5	17	No	(Hagberg, 2008)
	Västerås CHP plant unit 5	Biomass	0.49	170	485	120	Yes	2.9	6.5	13.6	No	(Starfelt et al., 2015; Wiesner, 2017) <sup>c</sup>
	Västerås CHP plant unit 7	Biomass	0.50	150	520	91	Yes	2.5	5.8	16.3	No	
	Johannes CHP plant, Gävle	Biomass	0.55	65	480	90	Yes	3.6	7	No	No	(Cuadrado, 2009)
	Silververket, Sala Heby	Biomass	0.39	32	480	80	Yes	3.6	11	No	No	(Ghaffarpour and Ros, 2018)
	Strängnäs CHP plant, Strängnäs	Biomass	0.45	36	482	72	Yes	No	3	No	Yes, 15 bar	(Erneby, 2012)
	Västerås CHP plant unit 6	Waste	0.44	159	470	75	Yes	2.3	6	No	No	(Beiron et al., 2019)
	Lillesjö CHP plant, Uddevalla	Waste	0.36	38	400	40	Yes	No	6	No	No	(Öberg, 2017)
Steam cycles modeled with reboiler steam extracted from primary steam	Dåva 1 CHP plant, Umeå	Waste	0.38	55	400	40	No	2	6	No	No	(Spett, 2006)
	Uppsala CHP, Uppsala	Waste	0.20	60	226	20	No	No	No <sup>a</sup>	No	Yes <sup>a</sup>	(Djurberg, 2020; Jung, 2010) <sup>c</sup>
	Sävenäs CHP plant unit 3, Göteborg	Biomass	0.16	95	220	20	Yes <sup>a</sup>	No	6	No	No	
	Munkegårdsverket, Kungälv	Biomass	0.13	23	224	29	Yes <sup>b</sup>	No	No	No	No	(Pettersson and Eriksson, 2006)
Eksjö CHP plant, Eksjö	Waste	0.11	20	197	16	Yes <sup>b</sup>	No	No	No	No	(Fransson et al., 1998)	

DH, district heating; LPFWH, low-pressure feedwater preheater; HPFWH, high-pressure feedwater preheater.

Power-to-heat ratios refer to nominal steam cycle performances (excluding flue gas condenser heat production).

<sup>a</sup> Uses primary steam instead of turbine extraction.

<sup>b</sup> Uses hot water instead of turbine extraction.

<sup>c</sup> Personal communication with plant employees.

**Table 2**

Average compositions of municipal solid waste and biomass wood chips used as fuels – as-received basis (The Swedish Environmental Protection Agency, 2004). The biogenic share of waste is obtained from (Statistics Sweden, 2019).

Fuel	Wood chips	Municipal solid waste
Fuel composition [wt%]		
C	32.9	32.9
H	3.9	4.5
O	26.7	21.3
N	0.2	0.5
S	0.0	0.4
Ash	1.3	10.5
Water	35.0	30.0
Biogenic share [%]	100	52

**Table 3**

Plant merit order and minimum load levels of heat production units in district heating networks. Industrial and peak capacities are considered as aggregates with continuous load ranges; therefore, a minimum load level is not applied for these plant types.

Running order	Plant type	Minimum load level
1	Industrial excess heat	-
2	Waste-fired CHP plants	0.7
3	Biomass-fired CHP plants	0.4
4	Other units (peak plants)	-

applicable for a certain DH network, the next plant type in order is operated instead. If there is more than one plant in a category, the plant with the most recent commissioning date is taken into operation first. “Other units” refer to heat production technologies such as heat only boilers, heat pumps, electric boilers, and reserve CHP plants. Industrial excess heat deliveries are assumed to be constant throughout the year and always used in full, when applicable.

The load level of each plant for each hour of the year is determined according to the following set of logical conditions.

- 1 If the hourly heat demand is lower than the maximum heat production of the first plant in the running order, the CHP plant load level is set to part load to match the heat demand.
- 2 If the heat demand is higher than the CHP plant maximum heat production, the load level of the CHP plant is set to full load.
- 3 If there are more CHP plants available in the DH system, the procedure is repeated until the heat demand is met.
- 4 If the heat production of the CHP plants is insufficient to cover the demand, peak units are started.
- 5 A sub-loop ensures that CHP plants do not operate below the minimum load level, by lowering the load of the previous unit.

The plant operation is determined for each hour of the year separately, without dynamic effects, i.e., maintenance stops, ramp rates and minimum up/down times are neglected, and load changes are assumed

to be instantaneous. The possibility to use thermal energy storage is not reflected in the calculations.

The outputs from the model are the hourly heat and electricity production levels from each CHP plant, as well as the associated CO<sub>2</sub> emissions. The carbon capture process is assumed to be in operation at all hours when each respective CHP plant is running, with 90% capture of CO<sub>2</sub> from the flue gas flow.

2.4. Cost estimations

A marginal abatement cost curve for CO<sub>2</sub> capture from Swedish CHP plants is developed that includes costs for the CO<sub>2</sub> capture and the transport of CO<sub>2</sub> from the plants to intermediate storage hubs (denoted as “Local transport cost”). Fig. 4 illustrates the parts of the CO<sub>2</sub> supply chain that are included in the cost estimation.

2.4.1. Capital cost of absorption, compression, and liquefaction plant

The capital expenditures (CAPEX) related to the CO<sub>2</sub> capture, compression and liquefaction plant are estimated based on the work of Eliasson et al. (2021). The absolute CAPEX is a function of plant size, i.e., the mass flow of CO<sub>2</sub> captured,  $m_{CO_2}$  [kg/s], and can be approximated as a power function, as shown in Eq. (1) (Eliasson et al., 2021), to account for economy-of-scale benefits. Eq. (1) is based on detailed calculations of equipment-specific costs using sizing parameters, for capture plant designs that are dimensioned for different CO<sub>2</sub> flow rates, to which a power function has been fitted (Eliasson et al., 2021). Eq. (1) represents cases with a flue gas CO<sub>2</sub> concentration of 13%, which resembles the conditions typically found in CHP plants, together with an absorption plant designed to capture 90% of the CO<sub>2</sub> in the flue gases. The capture plant is dimensioned based on the CO<sub>2</sub> flow at CHP plant full load. The CAPEX is annualized with a discount rate of 7.5% and an economic lifetime of 25 years, including 2 years of construction time and a plant operational lifetime of 23 years. For the 118% heat recovery case, heat pump investment costs are estimated based on (Danish Energy Agency, 2020).

$$Absolute\ CAPEX\ (k\text{€}) = 15520 \cdot m_{CO_2}^{0.6339} \tag{1}$$

2.4.2. Operational cost of carbon capture

The CO<sub>2</sub> capture plant operational expenditures (OPEX) include variable and fixed costs. The fixed OPEX is calculated as 6% of the absolute CAPEX and includes maintenance, insurance, and labor costs. The variable OPEX of operating the steam cycle with carbon capture is expressed by Eq. (2) and comprises the cost of utilities needed to drive the absorption, compression, and liquefaction processes [cooling water ( $V_{cw}$ ), electricity ( $P_{el,CCS}$ ), and MEA make-up ( $V_{MEA}$ )], and the costs for lost electricity production and net DH delivery from the CHP steam cycle, including any capture plant heat recovery ( $\Delta_{el,SC}$  and  $\Delta_{DH,SC}$ ). DH generated by installing a new flue gas condenser in conjunction with the CCS retrofit ( $Q_{newFGC}$ ) is, when applicable, considered a new revenue stream and subtracted from the expenditures. Table 4 lists the assumed cost for utilities. To put the numbers in perspective, the cost of wood chips is around 20 €/MWh and the cost of municipal solid waste is

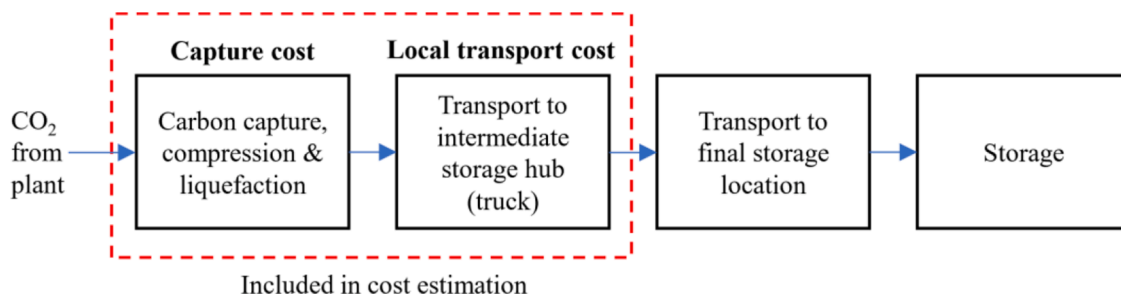

Fig. 4. Overview of the CO<sub>2</sub> supply chain and cost components included in the cost estimation. Intermediate storage stages between the chain components are omitted for clarity.

**Table 4**

Economic assumptions made for the calculation of the carbon capture operational expenditures.

Utility	Cost	Unit
Electricity ( $C_{el}$ )	40	€/MWh
District heating ( $C_{DH}$ )	15	€/MWh
Cooling water ( $C_{cw}$ )	0.02	€/m <sup>3</sup>
MEA make-up ( $C_{MEA}$ )	2,000	€/m <sup>3</sup>

around -17 €/MWh (i.e., negative) in Sweden (excluding taxes) (The Swedish Energy Agency, 2021).

$$OPEX = C_{el}(-\Delta_{el,SC} + P_{el,CCS}) + C_{DH}(-\Delta_{DH,SC} - Q_{newFGC}) + C_{cw}V_{cw} + C_{MEA}V_{MEA} \quad (2)$$

The electricity and cooling water demands to drive the CO<sub>2</sub> absorption and compression are estimated from a process simulation model developed in Aspen Plus (Ignell and Johansson, 2021), while the liquefaction electricity and cooling demands are based on a previous publication (Deng et al., 2019). The CO<sub>2</sub> is assumed to be compressed to 15 bar and -25°C. The impacts on steam cycle electricity and DH generation of operating with CCS are obtained from the steam cycle process simulation model. The utility demands are assumed to be independent of load level and to scale linearly with plant size.

#### 2.4.3. Local CO<sub>2</sub> transport cost

Once captured, compressed, and liquefied, the CO<sub>2</sub> is transported from the CHP plant to an intermediate storage hub, from where it is subsequently transported by ship to a permanent storage site (Fig. 4). The transport of CO<sub>2</sub> between the plant and the hub is assumed to be by truck, since all CHP plants have access to the road network infrastructure. Train transport could be a feasible option for CHP plants located in cities with access to the railway network, although it would not necessarily be cost-competitive compared to truck transport for sites with small volumes of CO<sub>2</sub> to transport (Kujanpää and Pursiheimo, 2017). Pipeline transport is not the most likely option in Sweden, due to the lack of an existing large-scale pipe grid, potential problems with public acceptance, and a rock-ground that makes the building of (underground) pipelines expensive (Kjärstad et al., 2016).

The present work considers seven intermediate storage hubs that have coastal locations (Table 5). Four of these are industrial sites with considerable CO<sub>2</sub> emissions that have been identified by Kjärstad et al. (2016) as possible hub locations. The remaining hubs are cities in regions with a high population density, i.e., there are several large CHP

**Table 5**

Intermediate storage hubs with (modeled) annual volumes of CO<sub>2</sub> to transport, including emissions from the CHP plants and industries located at the hub sites. The hub locations are shown in Fig. 9. The modeled CHP plant CO<sub>2</sub> captured corresponds to the case with 64% heat recovery.

Hub/site	Source of site emissions	CHP plant CO <sub>2</sub> capture potential (modeled) [kt/year]	Industrial CO <sub>2</sub> capture potential [kt/year] (Johansson et al., 2020)
Luleå	Industry (Iron & Steel)	720	3,300
Östrand	Industry (Pulp & Paper)	1,690	2,300
Stockholm	CHP plants	6,575	0
Oxelösund	Industry (Iron & Steel)	2,650	1,500
Lysekil	Industry (Refinery)	460	1,500
Gothenburg	CHP plants & Industry (Refinery)	1,580	500
Helsingborg	CHP plants	2,290	0

plants located nearby from which CO<sub>2</sub> could be collected.

The truck transport cost is calculated using the parameters listed in Table 6. The cost includes vehicle investments, fuel, labor and maintenance. Eqs. (3)–(6) present an overview of the calculations. The number of trucks required,  $N_{trucks}$ , is dimensioned based on the volume of CO<sub>2</sub> captured during 1 day of full-load operation ( $Y_{CO_2,day}$ ) and the volume of CO<sub>2</sub> transported per day per truck,  $Y_{CO_2,day,truck}$ , which is a function of the distance traveled,  $L$ , and vehicle speed,  $v$ . Truck drivers are assumed to work 8-hour shifts ( $t_{shift}$ ), with three shifts per day ( $N_{shifts,day}$ ). Drivers work 5 days per week, resulting in the need for 5 drivers per truck. The fuel cost is calculated based on the number of trips per day (with full-load operation,  $N_{trips,day}$ ) and the driving distance per trip. The cost of the drivers' wages and fuel costs are multiplied by the plant capacity factor, to account for seasonally varying operation. The maintenance cost is calculated as 5% of the investment cost.

$$t_{trip} = \frac{2L}{v} + t_{load} \quad (3)$$

$$Y_{CO_2,day,truck} = \frac{t_{shift}}{t_{trip}} * N_{shifts,day} * Y_{truck} \quad (4)$$

$$N_{trucks} = \frac{Y_{CO_2,day}}{Y_{CO_2,day,truck}} \quad (5)$$

$$N_{trips,day} = \frac{Y_{CO_2,day}}{Y_{truck}} \quad (6)$$

### 3. Results

The results are presented in three parts. First, the process simulation results are given. Second, unit commitments of DH systems with CCS from CHP plants are analyzed. In the third part, cost estimations are provided together with a marginal abatement cost curve.

#### 3.1. Process level impact of CCS on CHP plant performance

Operating CHP plants with carbon capture affects the plant performance. Fig. 5 plots the percentage of nominal steam cycle electricity and DH production retained when operating CHP plants with CCS. The symbols in Fig. 5a represent the 14 CHP plants modeled (Table 1) and are distinguished by fuel type (waste/biomass) and type of steam extraction (turbine/primary steam). The results pertain to full-load operation (i.e., boiler load kept constant with/without CCS) with a 90% capture rate.

The steam cycle electricity generation with CCS depends on where the reboiler steam is extracted. CHP plants with turbine extraction (yellow dots) retain 75%–85% of the nominal electricity production, independent of the steam cycle power-to-heat ratio and live steam parameters; the scattering of the yellow dots is mainly a result of the different available extraction pressures of the cases. Plants that use primary steam to drive the CCS reboiler have significantly lower levels of electricity retention, between 37% and 68%, where the higher values correspond to the hot-water boilers (Eksjö CHP plant and Munkegårdsverket) that have low power-to-heat ratios. The low percentage

**Table 6**

Economic assumptions made in the truck transport cost calculations.

Parameter	Value	Unit
Investment cost	280,000	€/truck
Fuel cost	0.6	€/km
Driver wages	80,000	€/year/driver
Loading time ( $t_{load}$ )	1	h/trip
Capacity ( $Y_{truck}$ )	33	m <sup>3</sup> CO <sub>2</sub> /trip
Speed ( $v$ )	50	km/h
Interest rate	10	%
Lifetime	10	years

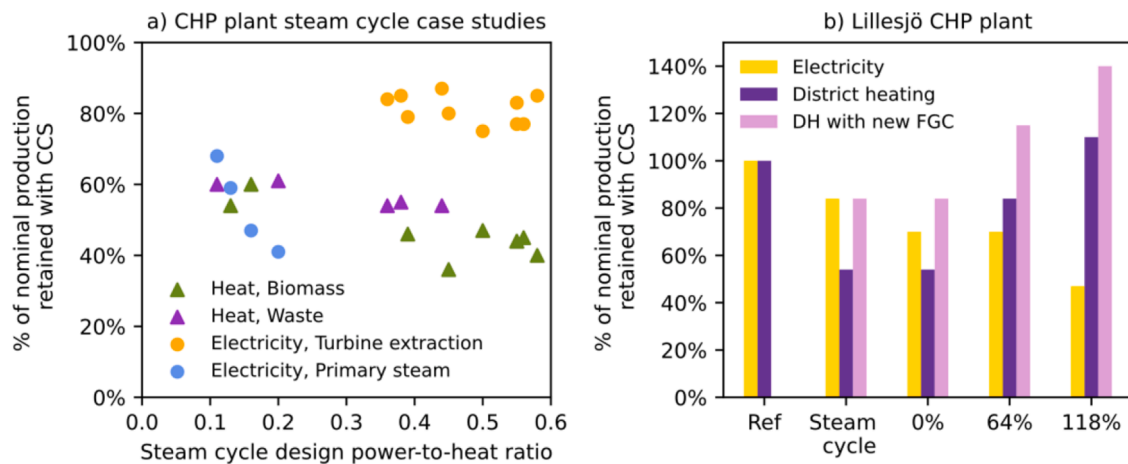

Fig. 5. Impact on CHP plant electricity and district heating generation levels when operating at boiler full load with carbon capture, expressed as percentage of nominal steam cycle production retained with CCS. (a) Steam cycle performance as a function of design power-to-heat ratio, type of steam extraction and fuel; displayed for the cases in Table 1. Each symbol represents one plant. (b) Performance when taking into account the energy demands of the absorption, compression and liquefaction processes, for the case of the Lillesjö CHP plant. “Ref” represents the performance without CCS, “Steam cycle” is the steam cycle performance with CCS, and the percentages 0%/64%/118% represent the overall CHP plant and carbon capture plant performances for different shares of heat recovery, as detailed in Section 2.3.1. DH, district heating; FGC, flue gas condenser.

of electricity retention is, of course, a result of extracting the primary steam before it has done any work in the turbine.

In terms of retained steam cycle DH generation, Fig. 5a shows that waste-fired plants (purple triangles) generally retain a larger share of the nominal heat production than biomass-fired plants (green triangles); 54%–67% and 36%–65%, respectively, where the higher values are obtained for cases with primary steam extraction to the reboiler. Note that the nominal steam cycle heat production excludes heat generation from existing flue gas condensers. Plants that combust biomass generate more CO<sub>2</sub> per MW<sub>th</sub> compared to waste fuels, due to the higher moisture content of the biomass (Table 2), which leads to a higher reboiler duty and steam demand, with less steam being left for DH production in the steam turbine condensers.

The overall plant performance is further dependent upon the electricity demand of the carbon capture plant and the amount of heat that is recovered from the capture plant to produce DH. Fig. 5b presents the CHP plant performance for the case of the Lillesjö CHP plant (waste-fired, modeled with a turbine extraction to drive the reboiler), for different heat recovery cases (Section 2.3.1) and the case in which a new flue gas condenser is installed together with the CCS retrofit. The electricity consumption of the capture plant causes a further reduction in net electricity production to 14%, which decreases the retention of electricity production to 47% if heat pumps are applied for heat recovery purposes (118% case). In contrast, there is a significant potential to increase the retention of DH production through heat recovery, up to 84% with heat exchangers and 110% with heat pumps. For plants that install a new flue gas condenser, the DH generation increases by an additional 20%–30%.

### 3.2. System level impact of CCS on CHP plant unit commitment

Given the impact on CHP plant performance of CCS, the overall DH system operation is also affected. Fig. 6 exemplifies the impact on DH system unit commitment when carbon capture units are installed at all CHP plants within a DH network. Fig. 6a shows the modeled system operation for a reference case without carbon capture, and Fig. 6b–d present the unit commitment of CHP plants with CCS, for different heat recovery cases. In Fig. 6b, there is no heat recovery from the capture plant, resulting in a significantly decreased heat output from the CHP plants (see also Fig. 5b). As a consequence, the number of full-load hours of the plants increases, especially for intermediate plants, to compensate for the lost heat production, as evidenced, for instance, by the increased

use of CHP3 (yellow) in Fig. 6b. However, the heat production from peak units (black) also increases significantly compared to the reference case, due to the decrease in heat production capacity.

When heat recovery is included in the unit commitment model, the CHP plant full-load hours are comparable to the reference case for the 64% heat recovery case (Fig. 6c) and decrease for the 118% case (Fig. 6d). Thus, with 64% heat recovery, the DH system operation is quite similar to the reference case when applying CCS. Heat recovery with heat pumps (118% case) increases the heat production capacity of the CHP plants to more than 100% of the nominal capacity (Fig. 5b), thereby reducing the need for heat production from intermediate and peak plants. The operation of base-load units is not significantly impacted by the share of heat recovered.

In Fig. 6, all CHP plants in the DH system are retrofitted with CCS. If only one CHP plant in the network is retrofitted, the impact on system dispatch is similar to that described above, albeit of lesser magnitude. For example, in the case without heat recovery, the level of DH generation from the CHP plant with CCS decreases and leads to increased heat delivery from peak units, although not to the same extent as when all CHP plants in the network are integrated with carbon capture, which prompts a greater need for peak unit heat production.

The differing CHP plant performances of the three heat recovery cases entail varying levels of energy outputs. Fig. 7 plots the changes in aggregated annual electricity and DH production and the CHP plant fuel use for all 110 CHP plants in the study, as compared to the reference case without CCS, and the corresponding amounts of biogenic and fossil CO<sub>2</sub> captured in each heat recovery case. The annual electricity generation is, of course, reduced compared to the reference independent of case, as shown in Fig. 5b, and even more so when heat pumps are used to increase the heat recovery (118% case). The total DH generated depends on the share of heat recovered, although it is lower than the reference in all cases. However, the use of heat pumps (118% case) increases the DH production to a level that is comparable to that of the reference.

Given the increased plant utilization observed in Fig. 6b, the CHP plant fuel use increases without heat recovery but is reduced when heat recovery is applied. The amount of biogenic CO<sub>2</sub> captured is linked to the CHP plant fuel use and is largest without heat recovery. All cases exceed the proposed target of 10 Mt of biogenic CO<sub>2</sub> captured per year. The amount of fossil CO<sub>2</sub> captured is 2.6–2.9 Mt/year in all cases.

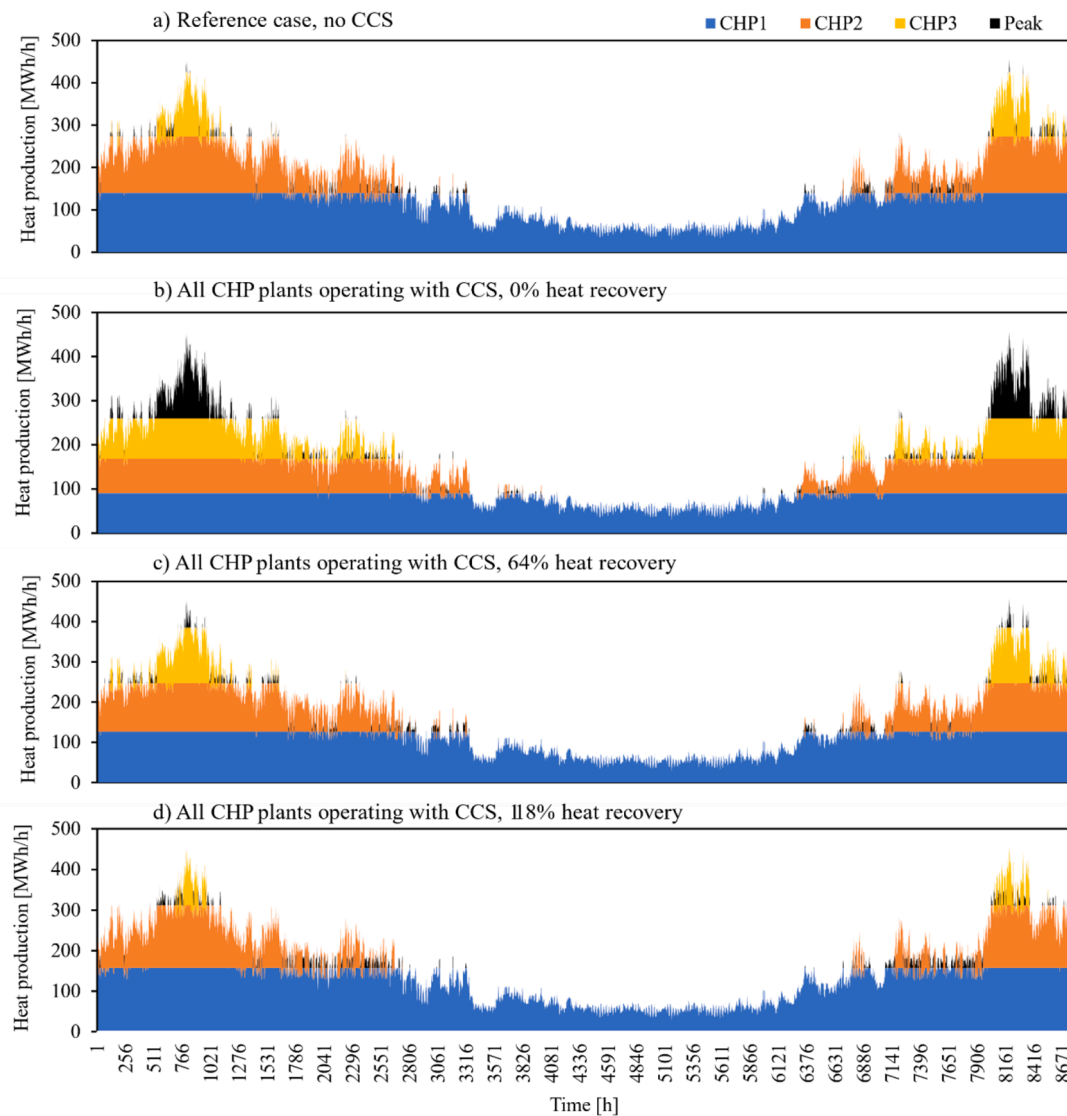

**Fig. 6.** Modeled unit commitment of combined heat and power plants, exemplified by the district heating network of Västerås, Sweden. Panel a shows a reference case without CCS, while panels b–d plot the system operation with 90% carbon capture from all CHP plants in the DH network with: (b) 0%, (c) 64%, (d) 118% heat recovery from the carbon capture plant, as detailed in Section 2.3.1.

### 3.3. Cost of carbon capture

#### 3.3.1. Capture plant CAPEX

Fig. 8 shows the variation of the specific CAPEX with CHP plant size and the number of full-load hours for the 64% heat recovery case. The cost, which ranges from 16 €/tCO<sub>2</sub> to more than 100 €/tCO<sub>2</sub>, increases for plants that are small and/or that operate for few full-load hours. Thus, if the level of plant utilization is low, less CO<sub>2</sub> is captured than can justify the investment made in the plant. Therefore, base-load plants with a high number of full-load hours show a lower specific CAPEX than an equally large intermediate CHP plant that operates exclusively during the cold part of the year. The impact of plant size on specific CAPEX is strongest for CO<sub>2</sub> flows <50 t/h, and the specific CAPEX is higher for a small CHP plant with high utilization than for a larger plant with a lower number of full-load hours.

#### 3.3.2. Operational expenditures of carbon capture

The cost components of the OPEX for CHP plants with CCS are presented in Fig. 9. Fig. 9a gives the cost components of the operational cost for the three heat recovery cases. The net OPEX, considering both the

costs for utilities and the revenue from recovered or new DH generation, is indicated in Fig. 9a by red dots where the white filling highlights plants that generate DH from new FGC installations. The net OPEX varies between 15 €/tCO<sub>2</sub> and 28 €/tCO<sub>2</sub> and is highest for the case without heat recovery (excluding new FGC). The main cost components are electricity and loss of DH generation. With heat recovery, the cost of lost DH production decreases, and even becomes negative (i.e., generating revenue) for the 118% case, albeit at the expense of increased electricity cost. Cooling water and MEA make-up are relatively small cost components. CHP plants that install a new FGC obtain an 8 €/tCO<sub>2</sub> reduction in OPEX independent of the level of heat recovery.

Fig. 9b shows the sensitivity of the specific OPEX to variations in electricity and DH prices. For a relative change in price of ±50%, the OPEX is increased/decreased up to 8 €/tCO<sub>2</sub> for the change in electricity price, and up to 6 €/tCO<sub>2</sub> for the change in DH price. Since the electricity and DH costs for the 0% case are of comparable magnitudes (Fig. 9a), changes in the electricity and DH prices have similar impacts on the OPEX. As the loss of DH decreases with heat recovery, the OPEX becomes less sensitive to DH price variations. Given the increased generation of DH in the 118% case, a reduction in DH price, in fact, causes an

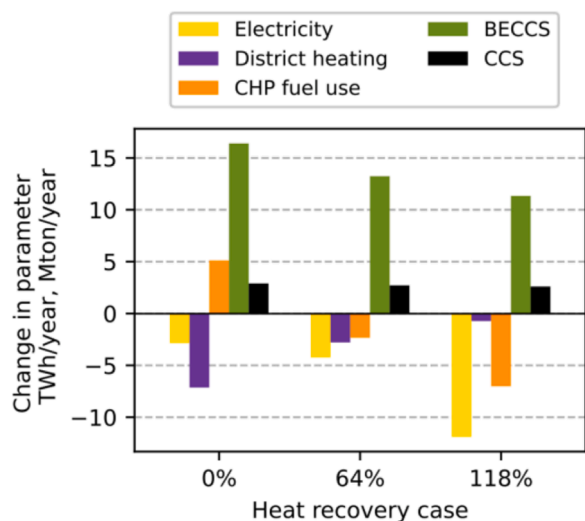

Fig. 7. Aggregated system impact of CCS on Swedish CHP plants’ annual electricity generation, district heating production, fuel use and carbon captured [biogenic (BECCS) vs fossil (CCS)], presented for the three heat recovery cases described in Section 2.3.1.

increase in the OPEX. The 0% and 64% cases have the same electricity consumption levels, and are therefore equally sensitive to electricity price variations, while the 118% case is affected more, due to the added heat pump electricity demand.

### 3.3.3. Costs for capture and local transport of CO<sub>2</sub>

Summing the cost components for capture and local transport, Fig. 10 visualizes the geographic distribution of CHP plant locations in Sweden, with intervals for the specific costs of capture and truck transport, estimated volumes of CO<sub>2</sub> captured per year indicated, and the seven transport hubs proposed in this study. The greatest potential for low-cost CO<sub>2</sub> capture is found close to the Stockholm hub (red markers in Fig. 10), where the population density is highest and many large CHP plants are located. The carbon capture plant CAPEX is the lowest for large plants with a high utilization time (Fig. 8), and the CO<sub>2</sub>

truck transport cost is generally proportional to the driving distance, although a low plant utilization time increases the specific truck transport cost (€/tCO<sub>2</sub>). However, the economy of scale of capture plant CAPEX can offset the increase in transport cost for long driving distances, so that there are plants that are located far from a hub that yield specific costs in the 70–100 €/tCO<sub>2</sub> interval (see inland orange markers in Fig. 10). The main governing factors for low-cost capture and local transport are, based on these results, plant size and utilization. Thus, having an abundance of CO<sub>2</sub> to capture (for a large part of the year) makes investments worthwhile. Plants that achieve a cost for capture and local transport that is lower than 70 €/tCO<sub>2</sub> have boiler thermal capacities in the range of 60–540 MW<sub>th</sub>, with at least 4,200 full-load hours, while capture and local transport costs in the range of 70–100 €/tCO<sub>2</sub> are feasible for plant sizes in the 14–355 MW<sub>th</sub> range that operate for at least 2,800 full-load hours. A low level of plant utilization can, thus, be balanced by a large plant size and can keep costs relatively low.

### 3.3.4. Marginal abatement cost curve

With the estimated specific costs of carbon capture and truck transport to the nearest transportation hub, and the modeled carbon capture potential of each CHP plant in the database, Fig. 11 presents the marginal abatement cost curves for CO<sub>2</sub> capture from Swedish CHP plants with a 90% capture rate, for the three heat recovery cases. Each bar represents the modeled CO<sub>2</sub> captured from one CHP plant, according to the applied DH system unit commitment model (Section 2.3), with the corresponding cost components given in €/tCO<sub>2</sub>-captured. As is also shown in Fig. 7, the total CO<sub>2</sub> capture potential from all the plants varies from 13.9 Mt/year in the 118% heat recovery case to 19.3 Mt/year in the case without heat recovery, reflecting different fuel consumption rates of the CHP plants. Of these CO<sub>2</sub> emissions, 2.6–2.9 Mt are of fossil origin, leaving some 10–16 Mt of negative emissions (Fig. 7). To place these numbers in context, the proposed target for Sweden by 2045 is 3–10 Mt/year of BECCS (SOU, 2020), and the total amount of fossil CO<sub>2</sub> emitted in Sweden in 2019 was 41 Mt.

Fig. 11 also shows that – as indicated previously – the cost of capture and local transport from the smallest or least-utilized plants is quite high, i.e., substantially higher than what is normally associated with CCS of around 100 €/tCO<sub>2</sub>. Some 6.4–7.8 MtCO<sub>2</sub>/year (biogenic and fossil) could be captured and transported to a hub at a cost less than 75

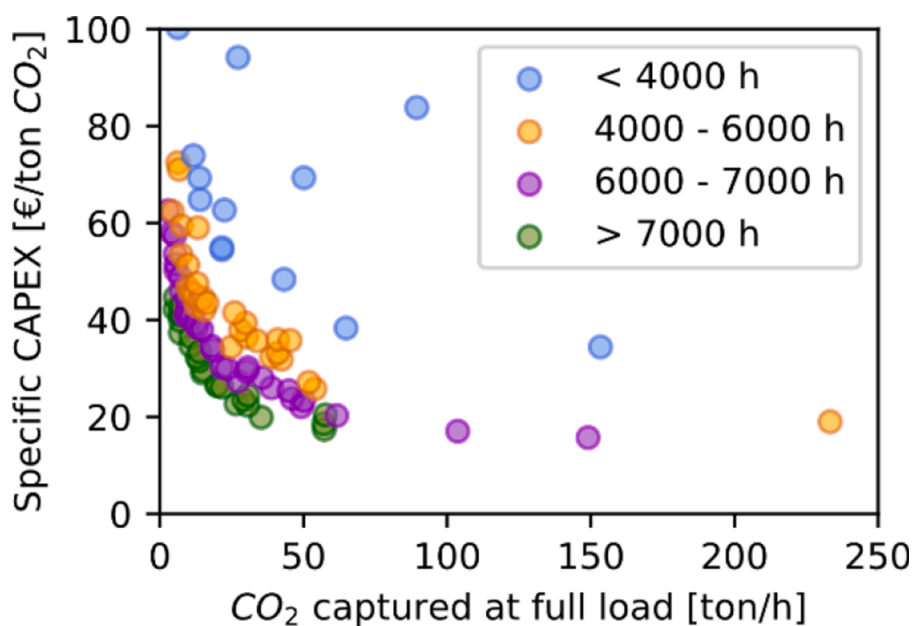
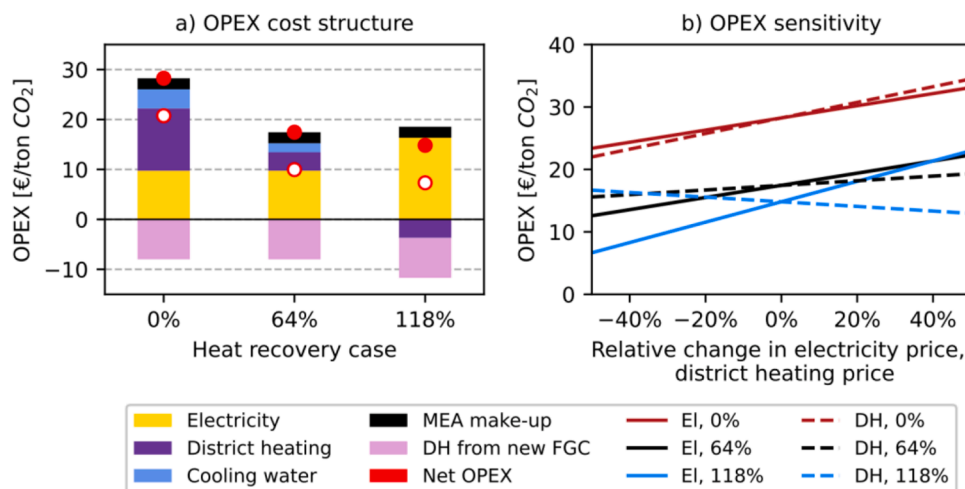
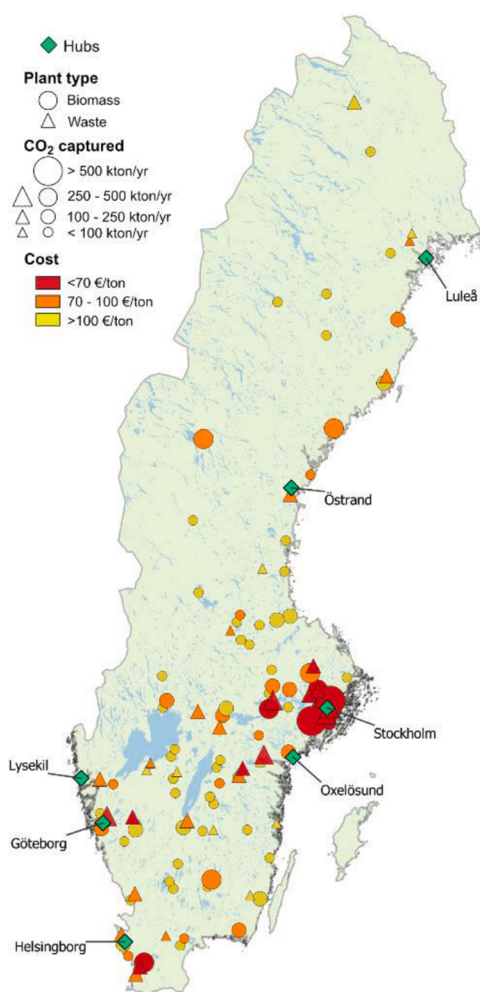

Fig. 8. Specific capital cost of a carbon capture plant (including absorption, compression and liquefaction) for CHP plants as a function of plant size (CO<sub>2</sub> flow) and number of full-load hours. The plotted costs are calculated for the 64% heat recovery case. Note that the y-axis is cut off at 100 €/tCO<sub>2</sub>.



**Fig. 9.** Specific operational expenditures for operating CHP plants with carbon capture. (a) Cost components of the operational cost for the three heat recovery cases. The red dots indicate the net operational cost, where the symbol with red fill indicates the net cost for plants that already have a flue gas condenser, and the white fill indicates the net cost for plants that install a new flue gas condenser (FGC) when retrofitting CCS. (b) Sensitivity of the operational cost to electricity price (EI) and district heating price (DH) variability (for plants without new FGC). The percentages in the legend refer to heat recovery cases (Section 2.3.1). (For interpretation of the references to color in this figure legend, the reader is referred to the web version of this article.).



**Fig. 10.** Geographic distribution of Swedish CHP plants and their respective potentials for annual carbon capture (biogenic and fossil CO<sub>2</sub>) and the associated specific cost of capture and truck transport, for the 64% heat recovery case. The proposed CO<sub>2</sub> transport hubs do not currently exist but are assumed to be located in larger harbors.

€/tCO<sub>2</sub>, while 10.6–13.6 MtCO<sub>2</sub>/year could be available at a maximum cost of 100 €/tCO<sub>2</sub>. However, note that these cost estimates do not include the costs for ship transport and CO<sub>2</sub> storage (see Section 4.3).

Overall, the costs remain relatively stable regardless of the heat recovery case. The decrease in OPEX with increased heat recovery is generally offset by an increase in CAPEX due to less CO<sub>2</sub> being captured and the additional investment cost of the heat pump in the 118% heat recovery case, so that the lowest cost of capture and truck transportation lies within the range of 45–50 €/tCO<sub>2</sub> in all the cases.

## 4. Discussion

### 4.1. Process-level considerations

The results of the process simulation in this work reveal the impact on steam cycle performance of CCS at full-load operation (Fig. 5). However, the practical feasibility of these results should be studied in greater detail with regards to part-load operation and turbine retrofits. Off-design simulations of part-load operation indicate that some plants might experience problems with reduced pressure in the turbine stage in which the reboiler steam is extracted, i.e., a steam pressure lower than the 3 bar needed to drive the reboiler. Part-load operation might, therefore, require either: (i) that less steam is extracted for CCS so that the steam pressure increases to a sufficient level, thereby yielding a lower capture rate; (ii) that steam is extracted at a higher pressure; or (iii) that an auxiliary boiler is used to provide steam to the reboiler. The steam flows extracted to drive the capture process are substantial, and the steam flow that remains in the turbine might be lower than the minimum level. In addition, the feasibility of extracting the required steam flows without extensive reconstruction of the steam turbine needs to be investigated.

This work assumes that the capture plant is dimensioned to capture 90% of CO<sub>2</sub> emissions at full load. For CHP plants that operate at full load as baseload units for a large part of the year, such an assumption can be considered reasonable. However, for CHP plants that apply load-following operation with a large extent of part-load operation during the year, it might be more cost-efficient to dimension the carbon capture plant for capturing a lower percentage of full load emissions, see for instance (Biermann et al., 2018). On the other hand, capture rates above 90% might also be feasible (Gao et al., 2019; Hirata et al., 2020), which would increase the potential for negative emissions, although the impact on the capture cost needs to be studied further.

It is important to point out that the reboiler duty applied in this study (3.6 MJ/kgCO<sub>2</sub>) should be regarded as a conservative estimate, and that lower values or other carbon absorption processes might represent feasible and competitive options, potentially resulting in improved process performance. Advanced amine solvent systems are commercially available, including Cesar-1, Cansolv and KS-1. The KS-1 system has been found to have reboiler duties in the range of 2.0 – 2.3 MJ/

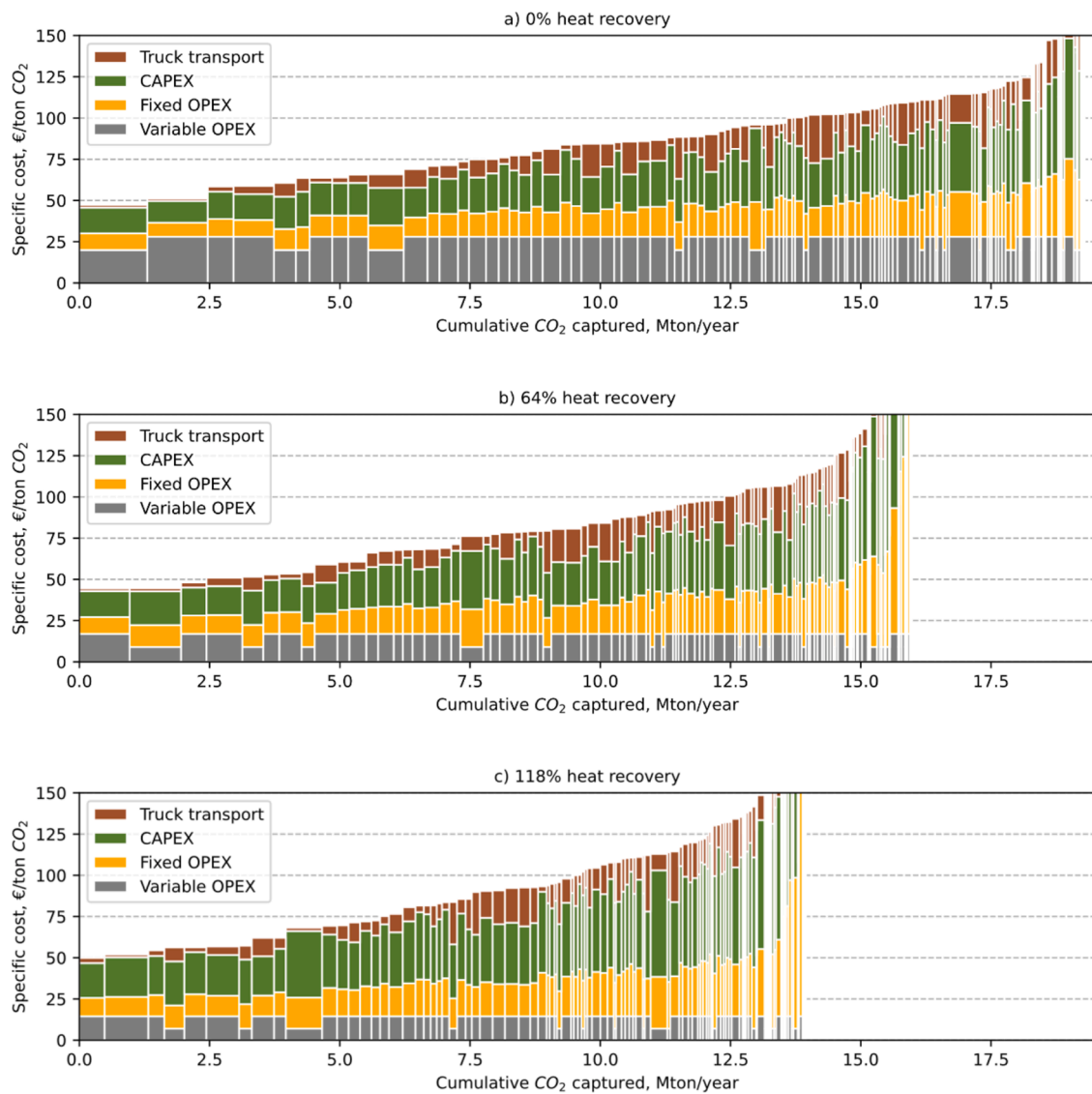

**Fig. 11.** Marginal abatement cost curve for CO<sub>2</sub> capture from Swedish CHP plants, with cost categories indicated by color. The x-axis gives the cumulative carbon capture potential (including biogenic and fossil emissions) for Swedish CHP plants given: (a) 0% heat recovery; (b) 64% heat recovery; and (c) 118% heat recovery from the carbon capture plant. Note that the y-axis is cut off at 150 €/tCO<sub>2</sub>.

kgCO<sub>2</sub> (Zheng et al., 2020), which is a significant reduction compared to the values assumed for MEA in this study, and could lead to a lower impact on the electricity and heat production levels, and a reduced operating cost.

#### 4.2. Energy system considerations

Operating CHP plants with carbon capture gives impacts not only on plant performance but also on the national energy balance (Fig. 7). DH is typically the main product of Swedish CHP plants, underlining the importance of maintaining heat deliveries. However, the 118% heat recovery case with heat pumps, which has the weakest impact on DH production, also results in a significantly reduced level of electricity generation. From the national electricity system perspective, the lost electricity generation might be replaceable, as CHP plants constitute less than 10% of the current Swedish electricity mix. However, in cities that have limited connection capacity to the national grid and a growing electricity demand, the local electricity generation capacity from CHP plants might be of high value and might compete with CCS.

This study assumes that the current product mixes and DH demands of DH systems are maintained, i.e., future development of DH companies

are not considered. In reality, some CHP plants may be shut down in the near future, and new plants may be built, although it is not obvious that CHP would be the preferred option in such a situation. As a consequence of persistently low electricity prices, heat-only boiler (HOB) plants are being discussed as CHP plant replacements in DH system planning. However, applying BECCS to HOB plants could also be of interest, at least for plants that are of reasonably large size. There may also be a development towards using the limited biomass resource for the production of higher-value products, such as biofuels. As an example, one of the DH companies in Sweden recently announced plans to produce aviation fuels, as a way to increase the utilization time of their production plants. The valuation of different energy products is, thus, a key element of the cost-efficient implementation of CCS in energy systems.

It should be noted that the present work does not account for the carbon footprint of the biomass supply chain and CO<sub>2</sub> transport, that is, emissions originating from, for example, biomass transport and processing, or truck emissions. An assessment of the BECCS supply chain can be found in (Fajardy and Mac Dowell, 2017).

### 4.3. Total cost of CCS

The cost estimations in this work do not include either the cost of ship transport of CO<sub>2</sub> from hub locations to the final storage site or the cost of storage. Thus, the total cost of CCS will be higher than reported here. Ship transport costs in the Nordic region have been estimated by Kjærstad et al. (2016) to be in the range of 14–22 €/tCO<sub>2</sub>, where the volume of CO<sub>2</sub> transported has a stronger impact on the cost than the distance travelled, since ship transport is rather insensitive to transportation distance. The collaboration of industries and/or CHP plant clusters in large-scale, joint, transport infrastructure systems is, thus, beneficial from the transport cost perspective.

Currently, the concept underlying the Northern Lights project for CO<sub>2</sub> storage in the North Sea, with Kollsnes as the final intermediate storage hub, seems to represent the most likely solution from a Swedish point of view, at least for the first projects. Ship transport and storage costs are predicted to be in the range of 30–55 €/tCO<sub>2</sub> (Sandberg, 2020), which would give a total cost for CCS applied to Swedish CHP plants in the range of 75–180 €/tCO<sub>2</sub>. In comparison, 23 MtCO<sub>2</sub>/year (including 15 Mt of BECCS) could be captured from Swedish industrial sites that emit at least 500 ktCO<sub>2</sub>/year at a cost of 80–140 €/tCO<sub>2</sub>, including the costs for transport and storage (Johnsson et al., 2020).

### 5. Conclusion

This work provides a techno-economic assessment of carbon capture applied to 110 existing Swedish biomass and waste-fired combined heat and power (CHP) plants, and estimates the potential for achieving negative CO<sub>2</sub> emissions via BECCS. By examining a unit commitment model of district heating (DH) system operation in which CHP plants are retrofitted with CCS, the results show that the total potential for negative emissions is 10–16 Mt annually (corresponding to 25%–40% of the total CO<sub>2</sub> emissions from all sectors in Sweden), depending on the extent of heat recovery from the carbon capture plant. This might be sufficient to meet the proposed targets for BECCS in Sweden of 2 MtCO<sub>2</sub>/year by 2030 and 3–10 Mt CO<sub>2</sub>/year by 2045. The estimated specific cost of CO<sub>2</sub> capture and transportation via truck to intermediate storage hubs is in the range of 45–125 €/tCO<sub>2</sub> for most CHP plants, depending on the plant size and utilization. Some 10.6–13.6 MtCO<sub>2</sub>/year could be available for capture at a cost of <100 €/tCO<sub>2</sub>, excluding the costs for ship transport and storage.

Operating CHP steam cycles with carbon capture causes reductions in electricity and DH production levels (of around 20% and 40%–60%, respectively), although up to 118% of nominal DH deliveries might be retained through heat recovery from the CO<sub>2</sub> capture plant and heat pumps applied to the capture plant cooling demand, at the expense of a further reduction in electricity generation (47% retained if heat pumps are used). The extent of heat recovery affects the DH system unit commitment, in that the case without heat recovery results in increased plant utilization, fuel use and carbon capture potential, while full heat recovery with heat pumps (118%) has the opposite effect, with a reduced number of full-load hours and less captured carbon.

Further research might focus on optimizing the design and integration of the carbon capture plant with the CHP plant to minimize the reduction in steam cycle electricity and DH production, as well as investigating the optimal share of heat recovery from the capture plant with respect to the local DH system.

### CRedit authorship contribution statement

**Johanna Beiron:** Conceptualization, Methodology, Data curation, Investigation, Writing – original draft, Visualization. **Fredrik Normann:** Conceptualization, Methodology, Writing – review & editing, Supervision, Funding acquisition. **Filip Johnsson:** Writing – review & editing, Supervision, Funding acquisition.

### Declaration of Competing Interest

The authors declare that they have no known competing financial interests or personal relationships that could have appeared to influence the work reported in this paper.

### Acknowledgments

This work is financed by the Swedish Energy Agency and Göteborg Energi AB. Part of this work was carried out within the Energiforsk project “CCS in the district heating sector”.

### Supplementary materials

Supplementary material associated with this article can be found, in the online version, at doi:10.1016/j.ijggc.2022.103684.

### References

- Beiron, J., Montañés, R.M., Normann, F., Johnsson, F., 2019. Dynamic modeling for assessment of steam cycle operation in waste-fired combined heat and power plants. *Energy Convers. Manage.* 198, 111926 <https://doi.org/10.1016/j.enconman.2019.111926>.
- Bhave, A., Taylor, R.H.S., Fennell, P., Livingston, W.R., Shah, N., Dowell, N.M., Dennis, J., Kraft, M., Pourkashanian, M., Insa, M., Jones, J., Burdett, N., Bauen, A., Beal, C., Smallbone, A., Akroyd, J., 2017. Screening and techno-economic assessment of biomass-based power generation with CCS technologies to meet 2050 CO<sub>2</sub> targets. *Appl. Energy* 190, 481–489. <https://doi.org/10.1016/j.apenergy.2016.12.120>.
- Biermann, M., Normann, F., Johnsson, F., Skagestad, R., 2018. Partial carbon capture by absorption cycle for reduced specific capture cost. *Ind. Eng. Chem. Res.* 57 (45), 15411–15422. <https://doi.org/10.1021/acs.iecr.8b02074>.
- Cooke, D.H., 1985. On Prediction of off-design multistage turbine pressures by Stodola's ellipse. *Trans. ASME* 107, 596–606.
- Cuadrado, R.S., 2009. Return Temperature Influence of a District Heating Network on the CHP Plant Production Costs [MSc Thesis]. University of Gävle.
- Smith, B., 2020. Microsoft will be carbon negative by 2030 [Accessed 2020-02-11] [WWW Document]. URL <https://blogs.microsoft.com/blog/2020/01/16/microsoft-will-be-carbon-negative-by-2030/>.
- Danish Energy Agency, 2020. Technology data - generation of electricity and district heating.
- Deng, H., Roussanaly, S., Skaugen, G., 2019. Techno-economic analyses of CO<sub>2</sub> liquefaction: impact of product pressure and impurities. *Int. J. Refrig.* 103, 301–315. <https://doi.org/10.1016/j.ijrefrig.2019.04.011>.
- Djurberg, R., 2020. Practical Implementation of Bio-CCS in Uppsala: a Techno-Economic Assessment [MSc Thesis]. KTH Royal Institute of Technology.
- Eliasson, Å., Fahrman, E., Biermann, M., Normann, F., Harvey, S., 2021. Efficient heat integration of industrial CO<sub>2</sub> capture and district heating supply. Submitted for publication.
- Erneby, R., 2012. Kortsiktig produktionsplanering i mindre fjärrvärmesystem [MSc Thesis]. Mälardalen University.
- Fajardy, M., Mac Dowell, N., 2017. Can BECCS deliver sustainable and resource efficient negative emissions? *Energy Environ. Sci.* 10, 1389–1426. <https://doi.org/10.1039/c7ee00465f>.
- Energiföretagen Sverige, 2021. Tillförd energi till fjärrvärme och kraftvärme - äldre statistik [Accessed 2021-06-24] [WWW Document]. URL <https://www.energiforetagen.se/statistik/fjarrvarmestatik/tillford-energi/tillford-energi-till-fjarrvarme-och-kraftvarme/>.
- Fransson, A., Kullendorff, A., Tilly, H.Å., 1998. Konvertering av hetvattenpanna till extern ångproduktion.
- Fuss, S., Johnsson, F., 2021. The BECCS implementation gap—a Swedish case study. *Front. Energy Res.* 8, 1–18. <https://doi.org/10.3389/fenrg.2020.553400>.
- Gao, T., Selinger, J.L., Rochelle, G.T., 2019. Demonstration of 99% CO<sub>2</sub> removal from coal flue gas by amine scrubbing. *Int. J. Greenh. Gas Control* 83, 236–244. <https://doi.org/10.1016/j.ijggc.2019.02.013>.
- Gardarsdóttir, S.Ó., Normann, F., Skagestad, R., Johnsson, F., 2018. Investment costs and CO<sub>2</sub> reduction potential of carbon capture from industrial plants - a Swedish case study. *Int. J. Greenh. Gas Control* 76, 111–124. <https://doi.org/10.1016/j.ijggc.2018.06.022>.
- Ghaffarpour, M.F., Ros, H., 2018. Integration of Thermochemical Heat Storage with a Municipal District Heating System: in Future Scenario with Large Variations in Electricity Price [MSc Thesis]. Mälardalen University.
- Gustafsson, K., Sadegh-Vaziri, R., Grönkvist, S., Levih, F., Sundberg, C., 2021. BECCS with combined heat and power: assessing the energy penalty. *Int. J. Greenh. Gas Control* 110, 103434. <https://doi.org/10.1016/j.ijggc.2021.103434>.
- Hagberg, L., 2008. Samproduktion av etanol och kraftvärme: Integreringsmöjligheter i energikombinat [MSc Thesis]. Swedish University of Agricultural Sciences.
- Hirata, T., Tsujiuchi, T., Kamijo, T., Kishimoto, S., Inui, M., Kawasaki, S., Lin, Y.J., Nakagami, Y., Nojo, T., 2020. Near-zero emission coal-fired power plant using

- advanced KM CDR process<sup>TM</sup>. *Int. J. Greenh. Gas Control* 92, 102847. <https://doi.org/10.1016/j.ijggc.2019.102847>.
- Ignell, V., Johansson, E., 2021. Local Infrastructures for CCS Clusters - a Case Study of Two CHP Plants in Gothenburg [MSc Thesis]. Chalmers University of Technology.
- IPCC, 2018. Global Warming of 1.5 C. An IPCC Special Report on the Impacts of Global Warming of 1.5C above Pre-Industrial Levels and Related Global Greenhouse Gas Emission Pathways.
- Johnsson, F., Normann, F., Svensson, E., 2020. Marginal abatement cost curve of industrial CO2 capture and storage – a Swedish case study. *Front. Energy Res.* 8, 175. <https://doi.org/10.3389/fenrg.2020.00175>.
- Jung, J., 2010. Energy Mapping of the Waste Incineration Plant in Uppsala [MSc Thesis]. Uppsala University.
- Kärki, J., Tsupari, E., Thomasson, T., Arasto, A., Pikkarainen, T., 2017. Achieving negative emissions with the most promising business case for bio-CCS in power and CHP production. *Energy Proc.* 114, 5994–6002. <https://doi.org/10.1016/j.egypro.2017.03.1734>.
- Kemper, J., 2015. Biomass and carbon dioxide capture and storage: a review. *Int. J. Greenh. Gas Control* 40, 401–430. <https://doi.org/10.1016/j.ijggc.2015.06.012>.
- Kjärstad, J., Skagestad, R., Eldrup, N.H., Johnsson, F., 2016. Ship transport — a low cost and low risk CO2 transport option in the Nordic countries. *Int. J. Greenh. Gas Control* 54, 168–184. <https://doi.org/10.1016/j.ijggc.2016.08.024>.
- Kouri, S., Tsupari, E., Kärki, J., Teir, S., Sormunen, R., Arponen, T., Tuomaala, M., 2017. The potential for CCUS in selected industrial sectors - summary of concept evaluations in Finland. *Energy Proc.* 114, 6418–6431. <https://doi.org/10.1016/j.egypro.2017.03.1778>.
- Kujanpää, L., Pursiheimo, E., 2017. Techno-economic evaluation of flexible CCS concepts in a CHP system. *Energy Proc.* 114, 6638–6649. <https://doi.org/10.1016/j.egypro.2017.03.1818>.
- Leviñh, F., Linde, L., Gustafsson, K., Dahlen, E., 2019. Introducing BECCS through HPC to the research agenda: the case of combined heat and power in Stockholm. *Energy Rep.* 5, 1381–1389. <https://doi.org/10.1016/j.egypro.2019.09.018>.
- Magnanelli, E., Mosby, J., Becidan, M., 2021. Scenarios for carbon capture integration in a waste-to-energy plant. *Energy* 227, 120407. <https://doi.org/10.1016/j.energy.2021.120407>.
- Öberg, S., 2017. Design of Partial CO2 Capture from Waste Fired CHP Plants. Chalmers University of Technology.
- Pettersson, N., Eriksson, N., 2006. Small Scale Generation of Electric Power in Arvika [MSc Thesis]. Karlstad University.
- Pour, N., Webley, P.A., Cook, P.J., 2018. Potential for using municipal solid waste as a resource for bioenergy with carbon capture and storage (BECCS). *Int. J. Greenh. Gas Control* 68, 1–15. <https://doi.org/10.1016/j.ijggc.2017.11.007>.
- Romanchenko, D., Odenberger, M., Göransson, L., Johnsson, F., 2017. Impact of electricity price fluctuations on the operation of district heating systems: a case study of district heating in Göteborg, Sweden. *Appl. Energy* 204, 16–30. <https://doi.org/10.1016/j.apenergy.2017.06.092>.
- Saarinen, L., 2008. Modelling and Control of a District Heating System [MSc Thesis]. Uppsala University.
- Sandberg, P., 2020. Northern lights - a European CO2 transport and storage network [Presentation slides]. Retrieved from <https://zeroemissionsplatform.eu/co2-ts-infras-structure/>.
- Schweiger, G., Rantzer, J., Ericsson, K., Lauenburg, P., 2017. The potential of power-to-heat in Swedish district heating systems. *Energy* 137, 661–669. <https://doi.org/10.1016/j.energy.2017.02.075>.
- SOU, 2020. Vägen till en klimatpositiv framtid - Betänkande av Klimatpolitiska vägvalsutredningen. Stockholm.
- Spett, T., 2006. Optimering av elproduktionen på Däva kraftvärmeverk [MSc Thesis]. Umeå University.
- Starfelt, F., Tomas-Aparicio, E., Li, H., Dotzauer, E., 2015. Integration of torrefaction in CHP plants - a case study. *Energy Convers. Manage.* 90, 427–435. <https://doi.org/10.1016/j.enconman.2014.11.019>.
- Statistics Sweden, 2019. Electricity supply, district heating and supply of natural and gasworks gas 2018, Sveriges officiella statistik.
- The Swedish Energy Agency, 2021. Trädbränsle-, torv- och avfallspriser [Accessed 2021-07-07] [WWW Document]. URL <https://www.energimyndigheten.se/statistik/den-officiella-statistiken/statistikprodukter/tradbransle-och-torvpriser/>.
- The Swedish Environmental Protection Agency, 2004. Rapport 5401 - Sammanställning av bränsledata. Halter och bränslenyckeltal.
- Tsupari, E., Arponen, T., Hankalin, V., Kärki, J., Kouri, S., 2017. Feasibility comparison of bioenergy and CO2 capture and storage in a large combined heat, power and cooling system. *Energy* 139, 1040–1051. <https://doi.org/10.1016/j.energy.2017.08.022>.
- Wiesner, E., 2017. Optimization and Energy Efficiency Measures in Modified Combined Heat and Power Plant Processes - a Case Study of Changed Processes in Mälarenergi Power Plant [MSc Thesis]. Uppsala University.
- Zheng, R.F., Barpaga, D., Mathias, P.M., Malhotra, D., Koech, P.K., Jiang, Y., Bhakta, M., Lail, M., Rayer, A., Whyatt, G.A., Freeman, C.J., Zwoster, A.J., Weitz, K.K., Heldebrant, D.J., 2020. A single-component water-lean post-combustion CO2 capture solvent with exceptionally low operational heat and total costs of capture - comprehensive experimental and theoretical evaluation. *Energy Environ. Sci.* 13, 4106–4113. <https://doi.org/10.1039/d0ee02585b>.