



CHALMERS
UNIVERSITY OF TECHNOLOGY

Design and development of an automatic dry waste segregator for household and institutional wastes

Downloaded from: <https://research.chalmers.se>, 2026-04-06 05:02 UTC

Citation for the original published paper (version of record):

Pai, R., Bangera, P., Shaikh, M. et al (2022). Design and development of an automatic dry waste segregator for household and institutional wastes. *Materials Today: Proceedings*, 52: 1048-1054. <http://dx.doi.org/10.1016/j.matpr.2021.10.487>

N.B. When citing this work, cite the original published paper.



Contents lists available at ScienceDirect

Materials Today: Proceedings

journal homepage: www.elsevier.com/locate/matpr

Design and development of an automatic dry waste segregator for household and institutional wastes

Rahul Rajendra Pai^{a,*}, Pavan Janardhana Bangera^a, Mohammed Mubeen Shaikh^a, Prajwal P^b, Rashmi P Shetty^b

^aChalmers University of Technology, Chalmersplatsen 4, Gothenburg 412 96, Sweden

^bDepartment of Mechanical Engineering, NMAM Institute of Technology, Nitte 574110, Karnataka, India

ARTICLE INFO

Article history:

Available online 14 November 2021

Keywords:

Automatic waste segregation
Dry waste separation
Magnetic waste separation
Municipal waste segregation
Paper and plastic separation

ABSTRACT

The rise in urban waste generation in India comes from the consumerist behaviour and the ever-increasing population density in the cities. A vast majority of this collected waste is dumped into landfills. The rural situation is somewhat akin except for the amount of waste generated is less and the traditionally informal method for waste recovery and reuse have been implemented for a long time. So, to scale down the perplexity and minimize the human effort, an enticing idea of a cost-effective 'Automatic waste segregator' has been conceptualized for segregation of waste. The automatic waste segregator is designed to be installed in housing colonies and organisations like schools and facilitates efficient sorting of dry wastes into three separate categories namely: ferromagnetic metals, paper and plastic. A shredder is used to mince the lump to the required size while a magnetic drum is implemented for removing ferromagnetic metals from the pile. A plastic and paper separating unit is designed and developed based on the thermal principle. Various explicit dynamics investigations have been carried out by means of a finite element tool to analyse the total deformation of components and transient thermal analysis in order to understand the temperature variation. The prototype segregates household and institutional wastes with an average overall efficiency of 86.78% and 91.82% respectively.

Copyright © 2022 Elsevier Ltd. All rights reserved.

Selection and peer-review under responsibility of the scientific committee of the International Conference on Smart and Sustainable Developments in Materials, Manufacturing and Energy Engineering This is an open access article under the CC BY license (<http://creativecommons.org/licenses/by/4.0/>).

1. Introduction

Every year, in India alone, approximately 40 million tonnes of urban municipal waste is generated. According to various reports, India has undergone unprecedented economic growth since 2011. The waste generation per capita has increased from 400 g per day to 500 g per day while the decadal waste generation per capita growth increased by 13.6% [1]. Municipal Solid Waste (MSW) generation is directly linked to the population density in the region or city, due to which a large quantity of waste is generated from bigger cities. As per the central pollution control board's MSW annual review report 2016–17 [2], Maharashtra, Uttar Pradesh and Tamil Nadu have a share of 19.68%, 13% and 12% respectively in the total MSW generation per day in India. The excessive quantities of waste being produced are increasing at an accelerated rate, a gruesome effect that is leading to a waste management crisis.

The two major waste handling methods widely implemented are landfilling and incineration. A landfill is an area of land in which waste is dumped and disposed. These landfill sites produce leachate that contains concentrated toxic chemicals. As waste decomposes, a combined chemical, thermal, and biological reactions release gases which are a mixture of methane and carbon dioxide. This gas being inflammable can cause a fire hazard at any given point [3]. Hence landfill is avoided to the maximum possible extent. Incineration is the process of developing energy from waste. This is achieved by combustion of waste thereby liberating energy which is mainly used to generate electricity. The gaseous emissions from solid waste incinerators have positively been recognised as carcinogenic. Incinerators require a massive capital investment with minute economic return [3]. In India, the waste generated has about 50% organic content as compared to 30% generated by developed countries [4]. This waste largely composed of organic waste involves excessive moisture content, thereby making incineration a poor option. These practices of waste disposal cause a lot of environmental hazards such as air pollution, ground-

* Corresponding author.

E-mail address: rahulrpai1997@gmail.com (R.R. Pai).

water depletion and other environmental peril leading to environmental instability.

The Government of India and various state governments have opted for Solid Liquid Resource Management (SLRM) [5] for effective solid waste management. This method involves four stages from the point of generation of waste to the disposal i.e., collecting the waste, separating the waste, sorting the waste and finally recycling the waste. Among these, the crucial stage in SLRM is separation. Due to the constraints in the source separation, wastes are collected in a disordered form. Once the wastes are mixed, it becomes laborious to separate them. Presently the segregation is done by manual labourers. This mostly proves to be inefficient and time-consuming. The handpicking method of sorting waste leads to a serious threat to the welfare of labourers who are constantly exposed to toxic substances.

To mitigate the hygiene threat on the handpicking labourers, segregation of wastes using automated machines would be an insightful idea. There has been quite a handful research done on this aspect, which could be rather termed as a time-consuming idea. The work done by Pushpa et.al [6] merely uses microcontroller as a crossing point for the sensors that are used for the waste segregation. Since the development of these complex circuits are tricky, it could turn into a more laborious process than the former approach. To relieve the complexity associated with the electronic circuits an alternative approach to the automated segregation could be using Programmable Logic Controller (PLC). The research done by Dwivedi et.al.[7] shows that the use of PLC in the segregation process would eventually give rise in the usage of sensors on top of the conveyor belt which could be even more intricate. This solution can also lead to an enormous system that only the commercial companies on a large scale can afford.

A smarter work done by Glouche et.al. [8] suggests using Radio-Frequency Identification (RFID) during the waste segregation process. This work gives rise to a thought on how economical the product will be by the time it gets in the market. The development of this technology will not entertain all the commercial companies as they're liable to add expenses on introducing RFID to their products. Moreover, the RFID scanners are delicate and fragile to be installed in a day-to-day life rough atmosphere. The works of Russel et.al. [9] also attempted an automated solution for the waste separation but eventually managed only to segregate glass and metal waste. This solution could be considered as an initiative on the concern towards the society, but more attention is needed to expand the scope of this idea as the household waste also contains paper and plastics. There are a few large-scale commercial waste segregators currently available. But the installation of these requires large capital investment. Given the cost of such pieces of machinery is sky-high, only a few of the mega-cities can afford to install it [10]. In order to mitigate this problem, the 'Automatic Waste Segregator' has been developed.

As it is observed from the various literature, the sorting of waste has a very prominent hand in effective waste management. But the current waste segregation methods like manual picking are futile and machinery on large scale are not cost-effective. This project of automatic waste segregator mainly deals with automating the waste separation process at the site of generation itself. The project is developed to segregate dry waste. The prototype intends to sort the chunk of waste into magnetic metals, plastic, paper, glass and wood. To design and fabricate a device involving indigenous technology and test the performance is the prime objective of this project. The machine designed is compact enough to be installed in colonies, apartments, organisations like schools and colleges which form the major source of dry wastes, thereby broadening the source separation which has always been a major concern. The aggregate of waste being dumped into the machine will render each component of garbage into various components in distinct

bins consequently separating the dry wastes. The metals, plastic and paper which constitute a major part of the junk, once sorted can be subsequently sent to respective recycling plants for further processing.

Thus, in this present work, the prototype developed can effectively separate the waste into various categories at the root level itself will drastically reduce the ill effects caused otherwise. It also saves the time spent on the process and the cost involved with it. The sorting also helps the local authorities to handle the waste with ease. Since the investment is not high it proves to be economical. The project is found to have high performance and efficiency in categorizing the waste into distinct bins.

2. Methodology

2.1. Overview

The overview of the developed methodology for the flow of waste through the process of segregation is shown in Fig. 1.

In the prototype developed the waste segregation takes place mainly in 3 stages.

1. Shredding of Waste
2. Magnetic separation
3. Plastic and paper separation

The detailed methodology of the process is as described below.

2.2. Shredding of waste

Shredding is the process in which the material is being cut and shrunk into pieces of required sizes. This becomes vital for further separation as smaller sizes facilitate easy sorting. Goforth, et al. [11] invented a shredder to avoid jamming of the blades, in which it is described to utilize side support bearings which are affixed to the walls of the cutting chamber of the shredder and act to support the shaft and hold it in position, while preventing the flow of comminute material between the cutters and thus preventing wear on the cutter discs. A 19-blade shredder has been employed in this prototype to shred the waste materials fed into it. The complete assembly is as shown in Fig. 2. The shredder is driven by a high torque low-speed motor of power 2 hp, run at a speed of 1440 RPM. The speed of the shaft carrying blades is 12 RPM, which is achieved by a three-stage pulley mechanism to obtain a speed ratio of 120:1.

2.2.1. Shredder blades

The blades are arranged on two hexagonal shafts of side 38.1 mm, one with ten blades while the other with nine. The blades made up of mild steel are subjected to heat treatment by the process of oil quenching in which the blade is heated to a temperature of 900 °C and then dropped into an oil bath. It has been found that the hardness of the blade subjected to Brinell hardness test has improved from 152 Brinell Hardness Number (BHN) to 173 BHN. Each blade has an outer diameter of 150 mm, width of 15 mm and a 12 mm depth of tooth. The blade is investigated by means of a finite element tool to analyze the deformation before implementing it in the prototype. The results obtained from the explicit dynamic investigation using ANSYS software [12] as the tool for a time span of 5 s by meshing it quadratically with a resolution of 4 is shown in Fig. 3. From this analysis a maximum deformation of 4.3×10^{-12} m has been observed and from a visual inspection conducted no significant deformation of the blade tip is observed after the multiple operations since most of the household and institutional waste have hardness less than 173 BHN. Thus, it can be concluded that the blades are suitable for operation in the shredder.

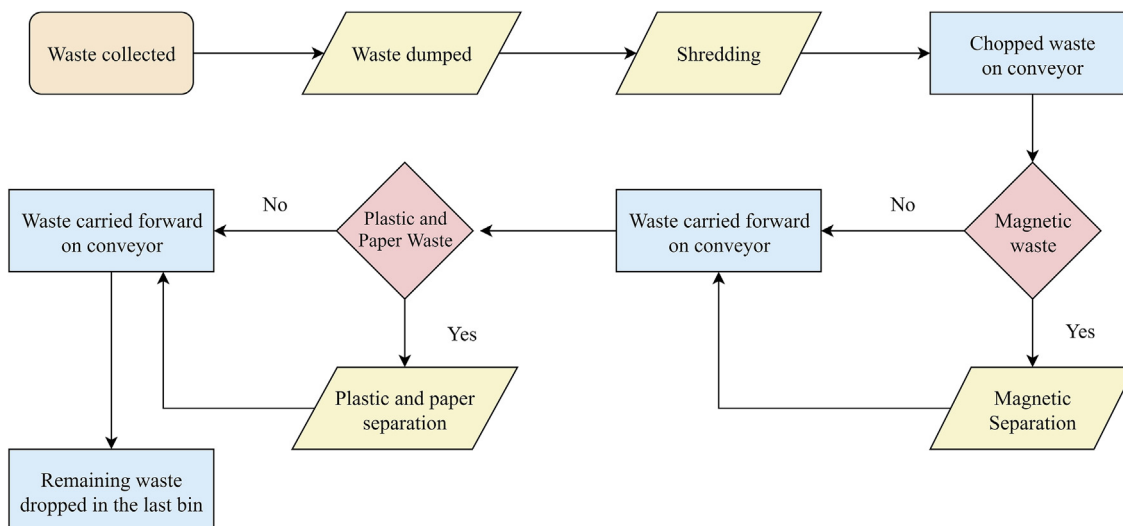

Fig. 1. Flowchart of working of the segregator.

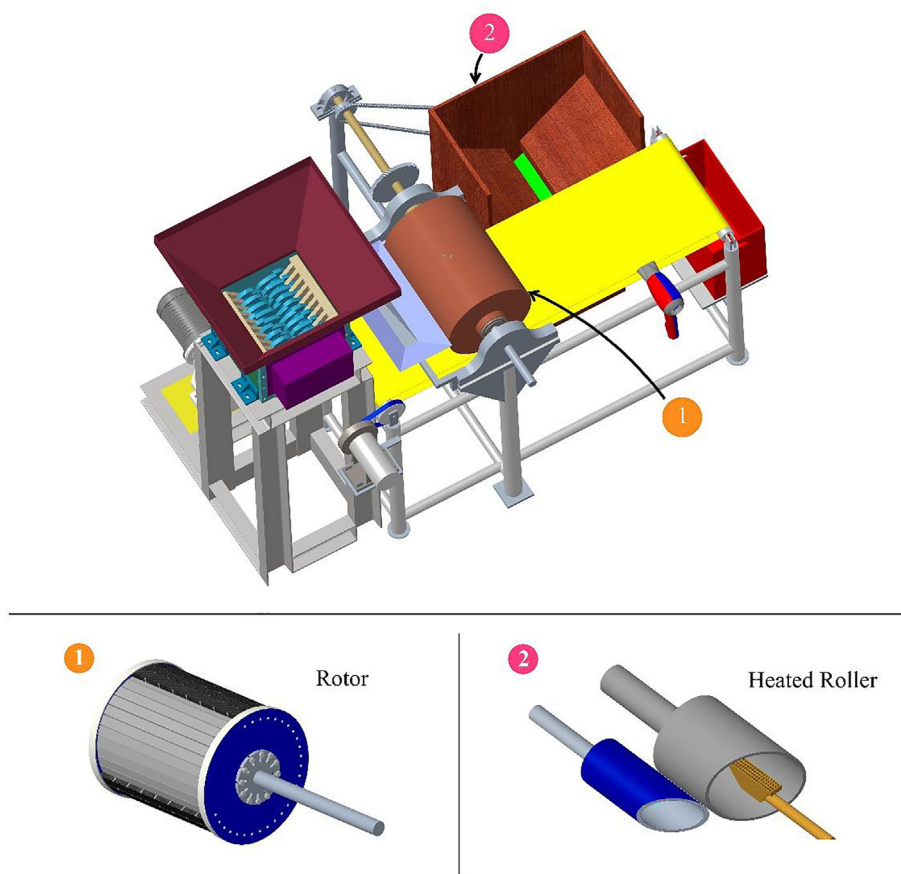

Fig. 2. Complete assembly of the prototype.

2.2.2. Shredder bushing

Mild steel bushings are provided between each blade to maintain enough clearance so that any waste particles fed into it will be crushed successfully. The bush has an outer diameter of 150 mm and a width of 16 mm.

2.2.3. Shredder gears

One of the shafts is provided with power from the motor through belt drives, while the other shaft is counter-rotated by

means of a pair of hardened EN8 carbon steel gears mounted at the other end of the shafts. The pair of gears of module 2 and 65 teeth each has been mounted. These gears have been designed and investigated by means of a finite element tool to analyze the deformation before implementing it in the prototype. The results obtained from the explicit dynamic investigation using ANSYS software [12] as the tool for a time span of 2 s by meshing it quadratically with a resolution of 4 is shown in Fig. 3. The deformation obtained is in the range of 1.6×10^{-5} m which has been considered

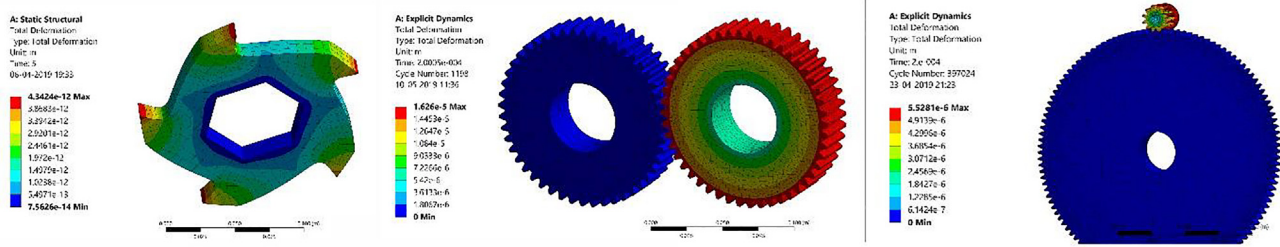

Fig. 3. Total deformation of the shredder blade, shredder gear and magnetic drum gear.

to be minimal and concluded that the gears are suitable for operation in the shredder. No significant deformation of the gear tooth is observed after the operation since gears are hardened and running at a low speed and is thus found more likely matching the analyzed result. This is carried out through visual inspection due to the lack of sophisticated deformation measuring facilities.

2.3. Magnetic separation

J. Svoboda et al. [13] have conducted research on magnetic methods of material separation and in their study have proved that the easiest way to increase the magnetising force is by increasing the gradient of magnetic induction. By a thorough adjustment of permanent magnets and by suitable placing or positioning of the magnetic poles, the gradient is generated. It is mentioned that in an axially arranged magnetic drum, alternation of the poles along the drum circumference occurs, while in a radial arrangement, the permanent magnets' polarity alternates across the width of the drum. In the prototype, a radial configuration magnetic drum is designed and implemented for separating magnetic materials. The drum has a cylindrical shell rotor with an open interior wherein a stator with a magnetic array is placed.

2.3.1. Stator

The stator is made up of mild steel sheet bent in the form of a cylinder which serves as a base. The ferrite magnets of size $39 \times 24 \times 10$ mm are mounted on this base such that $\frac{3}{4}$ part of the stator is covered with magnets while the remaining portion has no magnetic field. The complete assembly of the stator is depicted in Fig. 2.

2.3.2. Rotor

The rotor is entirely made of aluminium because the use of any ferrous material will restrict the rotation of the rotor in presence of a magnetic field. Since the wastes are shredded, the clearance between the conveyor and the drum is in the order of 5 mm. Hence, when the magnetic field encounters any of the ferrous materials moving on the conveyor belt, the materials are attracted towards the drum. When the rotor drum rotates, it carries the material attached to it. The materials attracted thus adhere to the drum cover until it reaches the position where the magnetic field is absent and falls off from the drum cover to the tray and gets collected in the bin provided especially for the ferrous material.

2.3.3. Power transmission

The drum is rotated at a constant low speed of 25 RPM for smooth functioning and operation of the set-up. A pair of gears is used to reduce the motor speed which is rotating at 250 RPM. Hence a specially designed gear setup with a ratio 10:1 is coupled with the motor and the shaft of the magnetic drum. A flange is used to connect the shaft to the drum cover. On calculation, the standard diameter of the shaft in order to avoid sagging due to

weight is found to be 28 mm and the critical speed of vibration is 9,544 RPM. The theoretically undefined spur gear of speed reduction of 10:1 has been designed traditionally and investigated by means of a finite element tool to analyse the deformation contour plot before implementing it to the main structure. The results obtained from the explicit dynamic investigation using ANSYS software [12] by meshing it linearly with a resolution of 2 is shown in Fig. 3. This has been done particularly because the smaller pinion has a very low size compared to the gear which eventually leads to a problem in mesh generation due to a lot of faces present in the gear. The deformation obtained is in the range of 5.5×10^{-6} m which has been considered to be minimal and concluded that the designed gear can be implemented in the main structure. The main concern here has been the validation of the analysed result of the pinion with the real deformation since it has been the weakest member due to the geometry and both having the same material properties. But no significant deformation of the pinion tooth is observed after the operation and is found more likely matching the analysed result. This is carried out through visual inspection due to the lack of sophisticated deformation measuring facilities. The reason for the small deformation is that the gears are running at a very low speed, with adequate lubrication, and are run for a very short period of time which keeps the temperature of gears nearly constant throughout the operation. But if there is an increase in temperature due to prolonged use, this might affect the material properties of the pinion and there might be a slightly greater deformation in the pinion teeth compared to the present result. Hence it cannot be concluded that this gear design is 100% safe, rather it depends on the period of usage.

2.4. Plastic and paper segregation

Bahri and Eneroth. [14] have discussed various methods of separation plastic and paper separator. The study states that one method for removing thermoplastic material waste from an aggregate of waste is based on a thermal principle according to which thermoplastics become pliable on contact with the surfaces at elevated temperatures. Fyfe and Brown [15] explained the process comprising of moving the waste onto a thermoplastic removal surface; maintaining the surface at a temperature sufficient for the adherence of the thermoplastic material to the heated surface and subsequent scraping off whereas the paper fraction passes the hot surface unaffected. Michel Biron [16] has mentioned that thermoplastics begin to contract from a temperature of about 50°C . Due to the less mass density compared to other wastes, the paper and plastic wastes present along with the other wastes is blown by a blower placed on one side of the conveyor. Inside the unit, there are two rollers one rotating while the other is kept stationary. The rotating roller also known as the plastic roller is heated using a Liquid Petroleum Gas (LPG) burner placed within it. The arrangement of the burner is as shown in Fig. 2.

The burner has four rows with each row having 25 holes making it a 100 hole burner. The mass flow rate of the LPG required to have a uniform temperature distribution of 70 °C at the surface of plastic roller has been calculated analytically using the fundamental equations of heat transfer and is found to be 3.091×10^{-6} kg/s. In the prototype, this has been implemented using a needle valve. In the plastic roller, one of the flanges is provided with a bearing seat for placing bearing which keeps the LPG burner in place while the other flange is connected to the shaft. This rotates the roller using the motor of the magnetic drum connected by means of a sprocket and chain which reduces the speed from 25 RPM to 12.5 RPM. Both the flanges are provided with holes to facilitate the inlet and exhaust of the air within the roller.

The designed plastic roller is checked for temperature distribution by thermal analysis using ANSYS software [12]. A transient thermal analysis has been conducted with coarse tetrahedral shaped mesh. The result of temperature distribution from the analysis of roller and the burner is as shown in Fig. 4. From the analysis, the temperature at the surface is determined to be 65.491 °C and has been found to be 70 °C upon testing which is sufficient for plastic to adhere to the surface of the roller.

3. Results and discussion

This work aims at designing and developing a device which can segregate dry wastes with no human intervention. The metallic waste mainly consists of ferrous metals such as nails, safety pins etc., which are strongly influenced by the magnetic field. On the contrary, plastic waste consists of carry bags, covers and various other thin sheets of thermo-plastics, while paper wastes mainly include newspapers, tissue papers etc. It is very necessary to segregate these household waste at the root level of generation looking at the rise in the amount of waste generated day by day. The prototype developed has been tested for its efficiency for sorting of dry waste. The tests have been conducted for dry wastes from two different vicinities. The waste from household and a college has been collected and tested separately.

3.1. Household waste

The dry waste from 5 houses in a rural area has been considered for the test. The total weight of the waste accounted for 1.68 kg and the composition of the wastes is indicated in Fig. 5. The performance of each unit is determined individually and then finally the overall performance is determined.

3.1.1. Shredder

The performance of shredder has been measured by weighing each category of waste before and after shredding. This data has

been used to determine the efficiency of the shredder. Initially, a total weight of 1680 g dry household waste is dumped in the shredder hopper which included 154 g of metals, 456 g of plastic, 545 g of paper, 416 g of glass and 109 g of wood waste. Table 1 shows the efficiency of shredding for each material calculated using Equation (1).

$$\text{Efficiency of shredding} = \frac{\text{Mean weight of shred waste}}{\text{Mean weight of respective waste fed}} \times 100 \tag{1}$$

Efficiency of Separation

$$= \frac{\text{Weight of each constituent of waste discarded}}{\text{Total weight of respective constituent fed in that stage}} \times 100 \tag{2}$$

Equation (2) is used to calculate the efficiency of magnetic separation, blower, and plastic paper separation. The result of this calculation is presented in Table 2.

3.1.2. Magnetic drum

The magnetic drum performance has been measured by weighing the metal waste discarded in the bin placed for metal wastes. This in comparison with the total quantity of waste from the shredder is used to determine the efficiency of the magnetic drum. Out of the 152 g of magnetic metals coming out of the shredder 139 g is sorted while the remaining 13 g continues to move on the conveyor.

3.1.3. Blower

The plastic and paper waste are blown off by the blower placed on one side to the separate unit placed on the other side of the conveyor belt where they undergo further separation. Out of the 429 g of plastic and 542 g of paper moving on the conveyor 387 g of plastic and 526 g of paper is effectively blown into the plastic and paper unit while the remaining waste continues to move on the conveyor.

3.1.4. Plastic and paper unit

The plastic and paper waste which is blown to the separating unit by the blower is separated using the heated roller and are collected in two separate bins. The weight of the plastic and paper discarded into each of the bin is being monitored; the obtained result is used to find the plastic and paper unit efficiency in separating them. Out of 387 g of plastic and 526 g of paper wastes, 344 g of plastic and 516 g of paper wastes are collected in the correct bin and 30 g of plastic and 10 g of paper wastes are in the wrong bin. About 13 g of plastic waste is stuck on the scrapper.

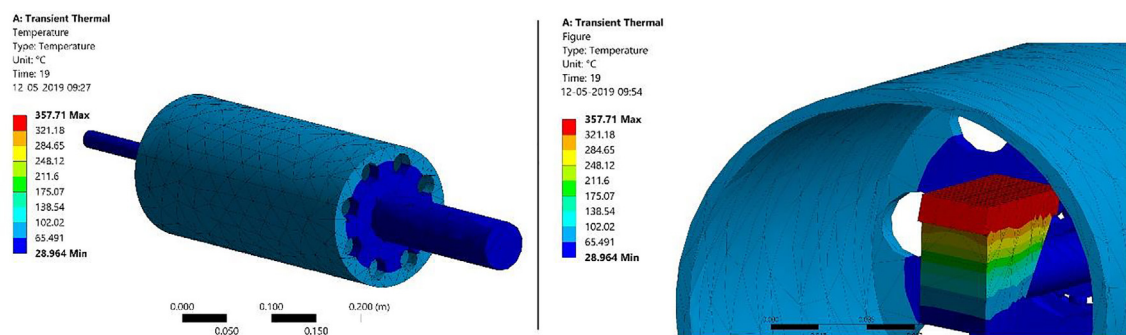

Fig. 4. Temperature distribution on the plastic roller and LPG burner.

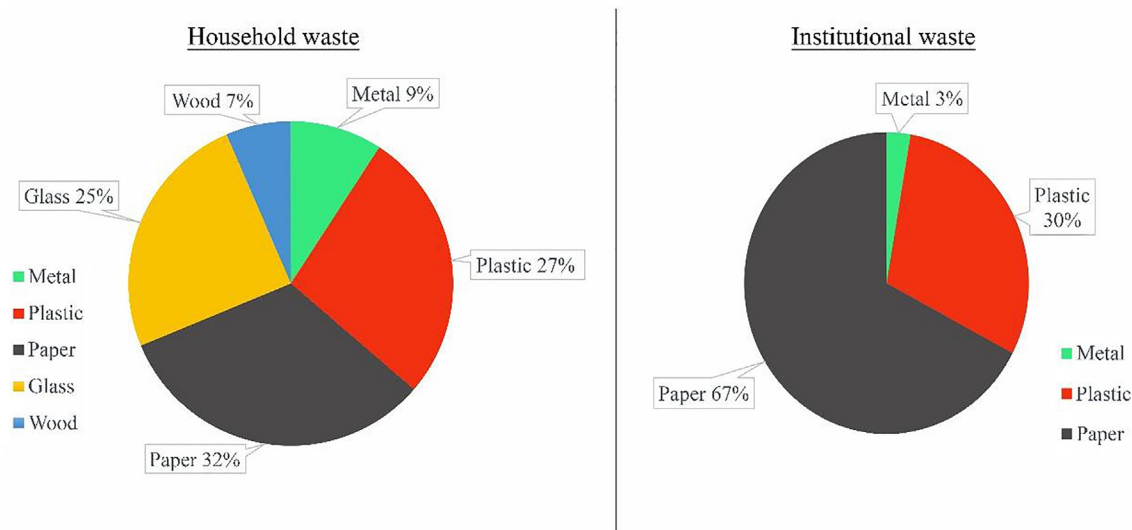

Fig. 5. Composition of household and institutional waste.

Table 1 Efficiency of shredding for various materials.

Type of Waste	Mean Weight of waste fed (g)	Mean weight of shred waste (g)	Efficiency (%)
Metal	154	152	98.39
Plastic	456	429	94.08
Paper	545	542	99.45
Glass	416	410	98.56
Wood	109	104	95.41
Overall Waste	1680	1637	97.44

Overall Efficiency

$$= \frac{\text{Weight of wastes discarded in each correct bin}}{\text{Total weight of respective waste before starting the process}} * 100 \tag{3}$$

As determined using Equation (3) the overall efficiency of magnetic metal separation is 90.25% while that of paper is 94.68% and that of plastic is 75.43%. The weight distribution of each of the constituents before and after the completion of segregation is given in

Table 2 Efficiency of segregation at various stages for different constituents

Sl. No.	Type of Waste	Weight of waste effectively discarded in the correct bin (g)	Weight of Non-Discarded waste (g)	Efficiency (%)
<i>Magnetic Separation</i>				
1	Metal	139	13	91.45
<i>Blower</i>				
1	Plastic	387	42	90.21
2	Paper	526	16	97.05
<i>Plastic and paper separation</i>				
1	Plastic	344	30*	88.89
2	Paper	516	10	98.10

* Additional 3.35% of the plastic is stuck on the scraper.

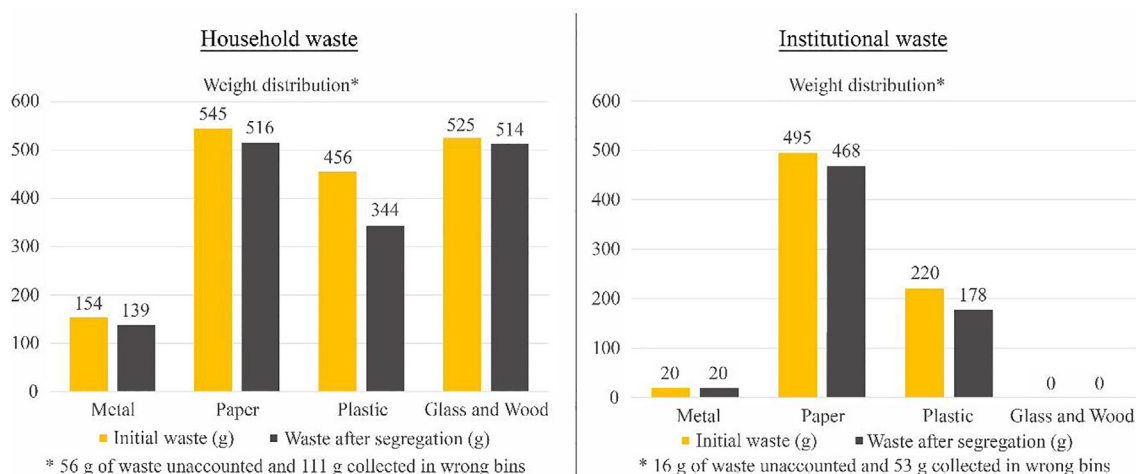

Fig. 6. Overall weight distribution before and after the separation of household and institutional waste.

Fig. 6. About 56 g of waste are lost during the process due to adhering to machine parts while 111 g of waste is collected in the wrong bins.

3.2. Institutional waste

The dry waste from a nearby educational institute has been considered for the test. The total weight of the waste accounted to 735 g and the composition of the waste is as shown in Fig. 5. The overall efficiency of magnetic metal, paper and plastic separation are 100%, 94.54% and 80.91% respectively. The weight distribution of each of the constituents before and after the completion of segregation is given in Fig. 6. About 16 g of wastes are lost during the process due to adhering to machine parts while 53 g of waste is collected in the wrong bins.

4. Conclusion

In the present day, the quantities of waste being produced are increasing rapidly while the current waste handling methods are leading to an environmental hazard thus making waste management important in order to maintain environmental stability. To scale down the perplexity and minimise human effort, an 'Automatic Waste Segregator' has been designed. Numerous components are investigated by means of a finite element tool to analyze the deformation contour plot and a transient thermal investigation for analysing the temperature variation before implementing them in the prototype. The designed machine is compact enough to be installed in housing colonies and organisations like schools. The prototype efficiently sorts the dry wastes into three separate categories namely: ferromagnetic metals, paper and plastic. In terms of household waste, the overall separation efficiency of metals is highest at 90.25% while it is lowest for plastic at 75.43%. Similarly, among the institutional waste, it can be noted that 100% efficiency is noted in metal segregation while 94.54% and 80.51% efficiency is noted in paper and plastic sorting respectively. Clearly, as the project has demonstrated this work will prove to be a step towards source separation thereby creating a cleaner and healthier environment.

Declaration of Competing Interest

The authors declare that they have no known competing financial interests or personal relationships that could have appeared to influence the work reported in this paper.

Acknowledgements

We would like to express our heartfelt gratitude to Mr. Kavan Kumar R and Mr. Praveen B of Steel Planet Padubidre for their support in the manufacturing of the project.

References

- [1] R.K. Annepu Online Sustainable Solid Waste Management in India 2012 New York.
- [2] Central Pollution Control Board, "Consolidated annual report on implementation of solid waste management rules," 2018. [Online]. Available: https://cpcb.nic.in/uploads/MSW/MSW_AnnualReport_2016-17.pdf.
- [3] A. Kan, General characteristics of waste management: A review, *Energy Educ. Sci. Technol. Part A Energy Sci. Res.* 23 (1) (2009) 55–69.
- [4] R. Joshi, S. Ahmed, C.A. Ng, Status and challenges of municipal solid waste management in India: A review, *Cogent Environ. Sci.* 2 (1) (2016) 1139434, <https://doi.org/10.1080/23311843.2016.1139434>.
- [5] R. P. R. Government of India, "Solid Waste Management in Rural Areas A Step-by-Step Guide for Gram Panchayats", no. May 2016 1 42.
- [6] M. K. Pushpa, A. Gupta, S. M. Shaikh, S. Jha, and S. V, "Microcontroller Based Automatic Waste Segregator," *Int. J. Innov. Res. Electr. Electron. Instrum. Control Eng.*, vol. 3, no. 5, 2015, doi: 10.17148/IJIREICE.2015.3529.
- [7] S. Dwivedi, M. Fernandes, and R. D'souza, "A Review on PLC based Automatic Waste Segregator," *Int. J. Adv. Res. Comput. Eng. Technol.*, vol. 5, no. 2, 2016, Accessed: Sep. 11, 2021. [Online]. Available: <http://ijarcet.org/wp-content/uploads/IJARCET-VOL-5-ISSUE-2-280-285.pdf>.
- [8] Y. Glouche, A. Sinha, and P. Couderc, "A Smart Waste Management with Self-Describing Complex Objects," *Int. J. Adv. Intell. Syst.*, vol. 8, no. 1 & 2, pp. 1–16, 2015, [Online]. Available: https://www.iariajournals.org/intelligent_systems/intsys_v8_n12_2015_paged.pdf.
- [9] M. H. Russel, M. H. Chowdhury, M. S. N. Uddin, A. Newaz, and M. M. M. Talukder, "Development of Automatic Smart Waste Sorter Machine," 2013, [Online]. Available: https://www.researchgate.net/publication/305131249_Development_of_Automatic_Smart_Waste_Sorter_Machine.
- [10] "New hi-tech automatic facility to segregate dry waste in Indore | Indore News - Times of India." <https://timesofindia.indiatimes.com/city/indore/new-hi-tech-automatic-facility-to-segregate-dry-waste-in-indore/articleshow/65060541.cms> (accessed Sep. 11, 2021).
- [11] B.D. Goforth, C.L. Goforth, J.G. Brooks, J.D. Brooks, *Close tolerance shredder, US5285973A* (1994).
- [12] Ansys® Workbench, "Release 19.1." .
- [13] J. Svoboda, T. Fujita, Recent developments in magnetic methods of material separation, *Miner. Eng.* 16 (9) (Sep. 2003) 785–792, [https://doi.org/10.1016/S0892-6875\(03\)00212-7](https://doi.org/10.1016/S0892-6875(03)00212-7).
- [14] M.S. Bahri, J.M. Eneroth, Method and apparatus for separating paper and plastic, *US4034862A* (1977).
- [15] R.D. Fyfe, V. Brown, Method of waste thermoplastic removal, *US3599788A* (1971).
- [16] M. Biron, *Thermoplastics and Thermoplastic Composites*. Elsevier Ltd, 2007.