



Experiences from RILEM TC 235-CTC in recommending a test method for chloride threshold values in concrete

Downloaded from: <https://research.chalmers.se>, 2026-04-04 11:14 UTC

Citation for the original published paper (version of record):

Tang, L., Frederiksen, J., Angst, U. et al (2018). Experiences from RILEM TC 235-CTC in recommending a test method for chloride threshold values in concrete. RILEM Technical Letters, 3. <http://dx.doi.org/10.21809/rilemtechlett.2018.55>

N.B. When citing this work, cite the original published paper.

Experiences from RILEM TC 235-CTC in recommending a test method for chloride threshold values in concrete

Luping Tang^{a*}, Jens M. Frederiksen^b, Ueli M. Angst^c, Rob Polder^d, Maria Cruz Alonso^e, Bernhard Elsener^c, R. Doug Hooton^f, Jose Pacheco^{d,g}

^a Chalmers University of Technology, Building Technology, SE-412 96 Gothenburg, Sweden

^b COWI A/S, Parallevej 2, DK-2800 Kongens Lyngby, Denmark

^c ETH Zurich, Institute for Building Materials, CH-8093 Zurich, Switzerland

^d Delft University of Technology, Materials and Environment, 2600 AA Delft, Netherlands

^e Eduardo Torroja Institute for Construction Science (IETcc), 28033 Madrid - Spain

^f University of Toronto, Department of Civil Engineering, Toronto, ON, Canada, M5S1A4

^g CTLGroup - Materials & Mechanics, Skokie, IL 60077, U.S.A.

Received: 12 March 2018 / Accepted: 18 September 2018 / Published online: 28 September 2018

© The Author(s) 2018. This article is published with open access and licensed under a Creative Commons Attribution 4.0 International License.

Abstract

Chloride threshold value is an important input parameter in service life predictions. There has been a need for a reliable method for testing this value in order to improve the understanding of basic factors influencing the corrosion initiation. For this reason RILEM technical committee (TC) 235-CTC was formed with the ultimate aim to recommend a suitable test method capable of delivering data with acceptable measurement uncertainty. During the TC's life, a test method was proposed and a Round-Robin Test (RRT) was organised to evaluate it. Due to the unexpected results from the RRT, the ultimate aim of the TC was not reached. There were some experiences obtained from the TC's work especially in designing the test method which are worthy for supporting future researchers continuing to search for a reliable test method for it. This technical letter presents the TC's experiences.

Keywords: Chloride; Concrete; Corrosion; Test method; Threshold

1 Introduction

The chloride concentration in concrete at which corrosion of reinforcement is initiated is an important parameter, called the critical chloride concentration (C_{crit}), or chloride threshold value, which is relevant for service life prediction of reinforced concrete. It has been well known for many years that this parameter is vital, but the scatter of data in the literature is huge [1-5]. This can be explained by the many influencing parameters and the lack of stringent definitions and measurement methods [3]. From reviewing the literature, the most dominant influencing factors for C_{crit} were identified to be 1) the steel-concrete interface, 2) the pH at the steel surface, and 3) the steel potential. It is considered a particular problem that many of the test setups used in the literature are not practice-related and thus cannot be expected to yield results applicable to engineering structures [3].

For a long time, there has been a need for a reliable method for testing C_{crit} in order to improve the understanding of basic factors influencing the corrosion initiation. On the other hand,

service life predictions are being demanded more and more often. C_{crit} is an important input parameter in service life predictions and therefore better knowledge from laboratory testing could improve the application in structures, similarly to chloride ingress modelling.

Consequently RILEM technical committee (TC) 235-CTC was formed in 2009 and worked on this topic until 2015. The ultimate aim of the TC was to recommend a suitable test method capable of delivering data with acceptable measurement uncertainty. During the TC's life, a test method was proposed and a Round-Robin Test (RRT) was organised to evaluate it. Although the ultimate aim of the TC was not reached due to the unexpected results from the RRT, it is still worthy to present the experience obtained in order to support future researchers continuing to search for a reliable test method for C_{crit} .

* Corresponding author: Luping Tang, E-mail: tang.luping@chalmers.se

2 Designing a test method for C_{crit}

A test method for C_{crit} always consists of the following components [3]:

- 1) a steel bar with a certain surface condition;
- 2) an alkaline medium (solution, cement paste, mortar, or concrete);
- 3) a procedure to introduce the chlorides (mixed in, diffusion, migration, etc.);
- 4) exposure conditions (temperature, moisture and oxygen)
- 5) a criterion to detect corrosion initiation;
- 6) a procedure to measure the chloride concentration at the rebar level at the time of initiation.

There are numerous options for each of these components and they have to be carefully selected as some of them are known to have a major influence on the results. In the following sections, the discussions of the TC and the decisions taken are summarised.

2.1 Steel bar with certain surface condition

In the literature, various surface conditions of steel bars have been used in such experiments: as-received, mill-scale, rusted, sandblasted, polished, chemically cleaned, etc. It has been recognized that the surface condition has a major impact on the measured value of C_{crit} [6-9]. Because the ultimate aim was to deliver repeatable and reproducible measurements of C_{crit} , The TC agreed to ensure a "reproducible and realistic surface condition". This means that procedures such as sandblasting, polishing, etc., were disregarded. As-received condition is not well defined and can vary very much. This was shown in additional investigations carried out within the TC, as reported elsewhere [10]. Therefore, testing of steel in the as-received condition was not considered as a reasonable option. Instead, the TC suggested a chemical cleaning followed by a pre-rusting procedure that was believed to be able to create a more reproducible, yet still practice-related surface state. Essentially, this procedure consisted of first removing all surface oxides by chemical cleaning protocol (HCl 1:1 + 3 g/l urotropine as an inhibitor), followed by exposure to high relative humidity (cycles of 24 hours immersion in tap water followed by 24 hours storage in a humid chamber in the range 90–98% RH) until a homogeneous pre-rusted surface was observed in order to achieve a condition where the rebars were homogeneously covered with red-brown corrosion products. However, during the RRT, it was found that this procedure introduced many problems, as will be discussed in section 3.

2.2 Alkaline medium

The TC agreed that no realistic C_{crit} could be measured in solution experiments. This is because of the fundamental

differences of corrosion onset in reactive porous materials such as concrete compared to bulk solutions. These differences in corrosion behaviour arise from the differences between steel-solution and steel-concrete interface (e.g. crevices, pores, ...), local buffering of pH due to the presence of solid phases, different transport phenomena of corrosion-relevant species, etc. Therefore, the TC decided to use concrete. The size of the maximum aggregate was specified as 16 mm. Using mortar or cement paste was disregarded in order to ensure practice-related conditions at the steel-concrete interface. In the RRT, a reference concrete was specified as the follows.

- Cement type: CEM I-SR 5 ($C_3A \approx 5\%$),
- water-binder ratio: 0.45,
- max size of aggregate: 16 mm,
- the volume ratio of cement paste: limited to 300 +/- 20 litres/m³, and
- the slump of fresh concrete: in the range of 120-150 mm.

A procedure to compact the specimens was also suggested. After standard moist curing each specimen was cut to a cover of 10 mm with a possibility for variation if needed.

2.3 Specimen geometry, rebar end, and replicates

2.3.1 Specimen design

It has been documented that vertically placed rebars during concrete casting revealed less voids than horizontally placed rebars [11] and that the rebar orientation has an influence on corrosion initiation [12-14]. Therefore, the TC agreed to place the rebar vertically in a mould.

Cubic 150 mm moulds were suggested owing to their easy availability. A jig made of e.g. plywood was suggested as a holder for placing the steel bar at the central position in the mould prior to filling, see Fig. 1. The jig was removed after the demoulding at the age of 2-7 days; specimens were then kept sealed in plastic until an age of 21 days. At this age the specimens were cut to produce a "roof" shape shown in Fig. 2. This shape was previously suggested by Nygaard and Geiker [15] for effectively eliminating salt crystallization by so called "salt walking" on the specimen surface above the liquid level.

2.3.2 Avoiding crevice corrosion or other undesirable rebar end effects

The proposed specimen geometry with the "roof" creates a relatively long distance for chlorides to reach the upper rebar end (where it protrudes from the specimen), compared with other zones of the exposed rebar, and thus contributes to avoiding corrosion initiation at the upper rebar end. As additional protection, the upper part of the specimen and the protruding rebar was coated with a transparent epoxy resin.

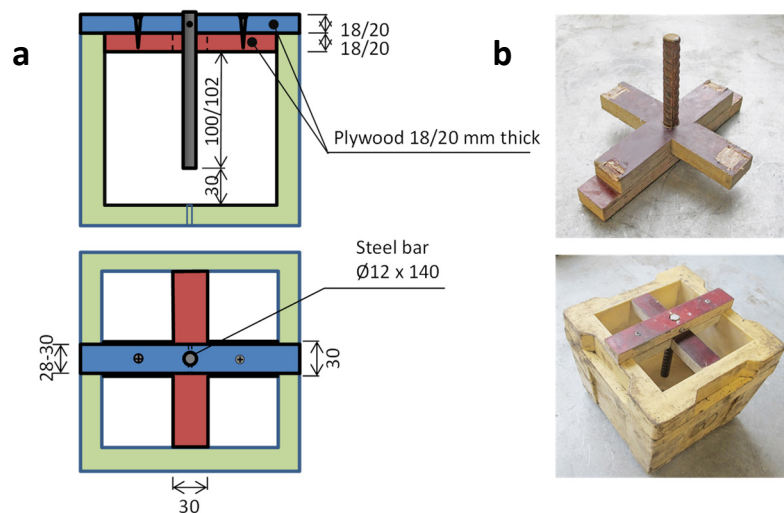

Figure 1. a) Illustration of the jig with a steel bar in a 150 mm cubic mould, b) Photographs showing a jig with a fixed rebar (upper) and as placed in the mould (lower) before casting.

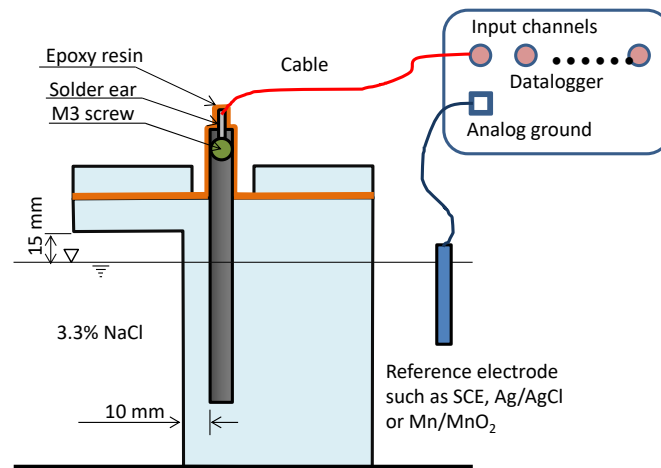

Figure 2. Illustration of a cut concrete specimen exposed to the chloride solution.

The proposed approach with the “roof” was considered to have advantages over other approaches used in the literature to avoid rebar end effects. The TC agreed that simple coating of rebar ends with an organic coating (e.g. epoxy) or with tape is not an ideal solution when these parts are exposed to chlorides because of the high risk of crevice corrosion. A better approach for rebar end coating is the one proposed by Lambert et al. [16], who suggested a duplex system to shield the rebar ends, that is, a coating of cement paste is first applied to the rebar surface and after hardening the paste is masked with an epoxy coating or a heat-shrink tube. Using this system the absence of crevice corrosion was confirmed without exception [17]. However, this duplex coating is relatively laborious. Thus, the TC favoured the approach described above where the geometry of the specimen ensures that no chlorides reach the upper rebar end.

The TC recommended that the rebar should not protrude from the lower part of the specimen, because in the near-surface zones, the moisture and oxygen content are generally different from the bulk concrete. In this study no treatment

of the rebar’s cut end was made because it was believed that this end was located at the lower part of the concrete where the local quality of concrete should be better than the middle or upper part due to less segregation of fresh concrete.

2.3.3 Number of replicate specimens

It is well known that experimentally determined C_{crit} exhibits wide variability, even under well controlled test conditions [1-4]. The variability increases when the size of the tested specimens (exposed steel surface area) becomes smaller [18-20]. According to previous studies [20, 21] the required number of replicate specimens is a function of rebar length. In order to make sure that the obtained results are relevant, that is, the average value of observed C_{crit} is within a given margin from the true average (with a given confidence level), the TC recommended testing ten replicates per test series for a rebar length of approximately 100 mm as used in the RRT.

2.4 Introducing chlorides

The TC agreed that mixed-in chlorides are not realistic, because mixed-in chlorides are known to change the hydration products, and hence concrete microstructure as well as pore solution pH and the initial passivation of the steel. In cases where service life modelling is relevant, chlorides typically stem from the environment. For the test method, this means that an approach is needed to accelerate chloride ingress from an external source. The TC adopted the procedure proposed in [15], consisting of pre-drying before immersion in chloride solution. The resulting capillary absorption of salt water accelerates chloride ingress compared to pure diffusion in moisture saturated concrete. The pre-drying procedure includes exposing test specimens together with dummy specimens (the parts of plain concrete cut from the procedure as described in section 2.3.1) in a drying environment. Dummy specimens were used to check the degree of drying after a certain duration of drying. For checking the degree of drying, a dummy was immersed in a 3.3% NaCl solution for 24 h as done in [15]. The degree of drying was assessed by measuring the chloride penetration depth using a colorimetric method. When the chloride penetration depth in the dummy was larger than 7 mm, that is, 3 mm less than the cover thickness, drying was considered to have developed satisfactory. At that time, the test specimens were immersed in the 3.3% NaCl solution for introducing chlorides (Fig. 2).

Other options to accelerate chloride ingress proposed in the literature were also discussed. This includes chloride ingress through migration (application of an external electrical field) and wetting/drying cycles. These options were, however, disregarded. Major reasons include the change in pore solution chemistry due to the external electrical field, the additional equipment needed and the extra work load caused by wetting/drying procedures that would have increased the costs of the test.

The upper part (about 20 mm) was exposed to air to avoid oxygen starvation – as done previously in [15]. Later findings from comparison with completely submerged specimens over several months of exposure, however, indicated that oxygen starvation did not occur (at least as long as no corrosion occurs).

2.5 Criterion for corrosion initiation

The criterion of the potential drop and the reasoning behind this is one of the key agreements reached in this committee. First of all, the TC agreed that the rebars should be under open circuit potential (OCP) during the test, that is, not polarised through either a short-circuited external cathode or with the help of a potentiostat/galvanostat. This was in spite of the rapid results obtained in [15], but was decided by a democratic process in the TC. The main reason was to ensure practice-related conditions. Under external polarisation, this is not the case, because 1) the potential to which the rebars are polarised likely differs from the OCP, which is known to greatly influence C_{crit} [3, 22], 2) galvanostatic or potentiostatic control prevents repassivation, which, under site conditions,

frequently occurs (see below). Thus, methods utilising polarisation were considered to be non-representative and conservative by the majority of the TC. Instead, it was recommended to monitor the open circuit potential of each rebar individually versus a reference electrode (such as SCE, Ag/AgCl or Mn/MnO₂) placed in the exposure solution at 2 h intervals.

It has been shown that depassivation of unpolarised steel embedded in concrete might take place over a certain period of time rather than a well-defined instant [17, 23, 24]. Typically, corrosion initiates and occurs for a relatively short time – indicated by a drop in corrosion potential – followed by repassivation – indicated by an increase of the potential towards the initial “passive” level. Subsequently, considerable time may pass until corrosion initiates again, upon which repassivation may again occur, etc. – until finally, a stable state of corrosion propagation is achieved. These depassivation/repassivation events can be explained by insufficient supply of chlorides towards the corroding spot. Both chlorides and hydroxyl ions migrate towards the anodic site in a competitive manner, and the availability of sufficient chlorides (also released from solid phases (“bound chlorides”) upon acidification) is critical for the corroding site to survive [25, 26].

This means that only if sufficient amount of chlorides is present, stable localised corrosion can be achieved (under open circuit conditions). The TC concluded that this may be the state relevant for practice, rather than the very first signs of corrosion that occur at (lower) chloride concentrations (e.g. under external polarisation), which however are not yet sufficient to promote stable corrosion propagation. Based on these considerations, the “time of stable corrosion” (t_{corr}) was defined as follows:

1. When the potential has dropped from its initial passive level by at least 150 mV in 24 hours or less, and the potential remains at this lower level over a period of 7 days.
2. If, instead of staying at the low level, the potential increases gradually over a week, the specimen is left for further monitoring.
3. The test is continued until stable corrosion is apparent from the potential being at least 150 mV more negative than the passive level for 7 days.

Considering that the corrosion on-set may be due to “false” chloride ingress (e.g. through cracks, crevices, etc.), the TC noticed that, if the time of stable corrosion is less than 14 days after the start of chloride exposure, the results for this specimen shall be discarded.

2.6 Measuring the chloride content

Once stable corrosion is detected, the specimen is removed from the exposure solution and the total (acid soluble) chloride content at the depth of the rebar is determined either by grinding in areas adjacent to the rebars or by measuring chloride profile in a dummy specimen exposed in the same solution. The TC agreed to express C_{crit} as total chloride by mass of concrete/cement rather than water-

soluble chlorides. Main reasons for this are the large uncertainties associated with test methods for water-soluble chloride concentrations [1], and the fact that also the bound chlorides are known to play a vital role in corrosion initiation [27]. This is because, upon acidification of the local environment after corrosion initiation, bound chlorides are locally released and thus contribute to establishing conditions for stable corrosion propagation (as described in section 2.5).

3 Results and Discussions

3.1 Results from RRT

In total, ten laboratories from different countries participated in the RRT with the reference concrete as specified in section 2.2. Only eight laboratories carried out the tests strictly in accordance with the specified test procedures. The range of open circuit potentials measured was in average between -150 to -20 mV SCE, in agreement with literature data for passive steel in aerated non-carbonated concrete. Among these eight laboratories only three of them observed corrosion initiation after a reasonable test duration (> 14 days and < 180 days). According to the results from these three laboratories (see Table 1), the measured chloride threshold values for the reference concrete varied from 0.6% to 1.6% with an average 1.05% by mass of cement. These results are within the range of C_{crit} reported in the literature [1-5]. The standard deviation of the measurement in each laboratory varied from 0.08% to 0.15% by mass of cement, corresponding to a variation of coefficient of repeatability 11.5% and reproducibility 47.6%. In comparison with other studies reporting statistical data on C_{crit} as reported by Vassie [28] and summarized by Angst et al. [20], this variability is considered relatively small. For the laboratories without observation of corrosion initiation after 290 to 800 days exposure in chloride solutions, the measured chloride content at the steel depth varied from 0.5% to 2.8% by mass of cement.

Table 1. Results from these three laboratories observed corrosion.

Lab	Cement	Corrosion start	C_{cr} , % ²⁾	CoV ³⁾	Dry depth
LMDC	CEM I 42.5N	88-160 days	0.94	8.5%	≈9 mm
LNEC	CEM I 42.5N	19-61 days	0.61	24.6%	≥10 mm
SZU	PI 42.5 ¹⁾	41-49 days	1.59	13.3%	≈10 mm

¹⁾ Chinese cement similar to CEM I 42.5N

²⁾ By mass of cement

³⁾ Coefficient of variance

3.2 Experiences made

It is considered a particular problem that in many laboratories participating in the RRT, corrosion initiation was not observed even within test periods exceeding one year or in certain cases two years. This was ascribed to a number of possible issues:

- 1) Pre-rusting procedure: Additional electrochemical tests (linear polarisation measurements and cyclic

voltammetry) revealed that in some cases, the rust layers formed with the pre-rusting procedure strongly affected the electrochemical behaviour of the rebars. It is believed that the Fe^{2+}/Fe^{3+} couple present on the steel surface strongly dominated the potential of the rebars. It has been reported that rusted steel has a 10 times higher cathodic oxygen reduction current compared to steel with mill scale [29]. This was explained by the fact that the sites for oxygen reduction are reduced by γ -FeOOH crystals – the more rust is available to be reduced the more intense is the cathodic oxygen reduction [30]. The potential of the rusted steel surface is thus hold in the passive range by the high exchange current density of the oxygen reduction reaction. This “chemical potentiostat” prohibited a drop of the rebar potential even if corrosion may have initiated locally, which made detection of corrosion initiation based on the stipulated criterion difficult. This effect is expected to be stronger when higher amount of surface rust was formed. Unfortunately, no procedure nor specification was defined for assessing the degree of rust formed during the pre-rusting procedure, which led to significantly different behaviour of the samples manufactured in the different laboratories.

- 2) Too low specified value for the minimum degree of drying. In the proposed test, the degree of drying was specified as the measured depth of colour change (chloride penetration) being larger than (cover thickness – 3 mm). The results from the RRT showed that specimens showing corrosion initiation within a reasonable test duration often had the depth of colour change after drying in the range of (cover depth -/+ 1 mm), whilst in most of the specimens having chloride penetration depths after drying equal to (cover depth – 3 mm), no corrosion was observed, even after much longer exposure.
- 3) Other possible causes such as surface densification of the concrete due to calcite formation have been considered as influencing factors.

Other experiences include the following:

- In some tests, preferable corrosion initiation occurred at the lower rebar end (the cut end) [24]. This may be considered in future suggestions for specimen layout.
- Surface calcification was observed, probably due to superficial carbonation if an unsealed box was used for pre-drying.

4 Conclusions and Outlook

4.1 Main conclusions from TC work

During the work of RILEM TC 235-CTC consensus was achieved regarding different important aspects of an appropriate test method for determining C_{crit} . The type of electrochemical measurement (free corrosion potential rather than external polarisation) was controversial within the TC, whilst consensus was obtained on the criterion for identifying open circuit potential corrosion initiation that may

acknowledge phenomena occurring in real structural conditions.

However, the performed inter-laboratory test revealed certain difficulties; accordingly, the method could finally not be recommended by the TC under its current procedures. Major problems were that the attempt to mimic realistic conditions at the steel-concrete interface by applying a pre-rusting procedure was found to negatively affect the method in several aspects. Another problem was that the test duration was much longer than expected – especially compared to the results obtained in [15].

4.2 Recommendations for future attempts to devise a laboratory test method for C_{crit}

In future work aiming at devising a test method to deliver repeatable and reproducible values of C_{crit} , it is recommended to keep the test conditions as close to the conditions in real structures as possible. Without saying that the approach chosen by the majority of this TC was the right one regarding the electrochemical conditions during the test, these conditions must be considered carefully. Also the creation of a reproducible and practice-relevant steel-concrete interface is crucial. Recent work by another RILEM TC [31] has revealed that mimicking realistic conditions at the steel-concrete interface in laboratory-made specimens presents a particular challenge. Nevertheless, a number of aspects should be considered with sufficient care when designing laboratory tests. Examples are the role of the casting direction (rebar orientation), the microstructure of the steel, the steel surface condition, and the moisture state.

It may also be mentioned that in recognition of the difficulties in producing specimens in the laboratory, a test method has recently been proposed that is in principle similar to the method developed in RILEM TC 235-CTC, but uses specimens taken from real structures [32].

References

- G. K. Glass, N. R. Buenfeld, Chloride threshold levels for corrosion induced deterioration of steel in concrete, Proc. Int. RILEM Workshop "Chloride penetration into concrete", Oct. 1995, Paris, France (1997): 429-440.
- K. Y. Ann, H. W. Song, Chloride threshold level for corrosion of steel in concrete. Corros Sci (2007) 49 (11):4113-4133. <https://doi.org/10.1016/j.corsci.2007.05.007>
- U. Angst, B. Elsener, C. K. Larsen, Ø. Vennesland, Critical chloride content in reinforced concrete - A review. Cem Concr Res (2009) 39 (12):1122-1138. <https://doi.org/10.1016/j.cemconres.2009.08.006>
- M. C. Alonso, M. Sanchez, Analysis of the variability of chloride threshold values in the literature. Mater Corros (2009) 60 (8): 631-637. <https://doi.org/10.1002/maco.200905296>
- U. Angst, O. Vennesland, Critical chloride content in reinforced concrete - State of the art, Proc. Concrete Repair, Rehabilitation and Retrofitting II - Proceedings of the 2nd International Conference on Concrete Repair, Rehabilitation and Retrofitting, ICCRRR, 2008 (ISBN 9780415468503), Cape Town, South Africa, (2009): 149-150.
- T. U. Mohammed, H. Hamada, Corrosion of steel bars in concrete with various steel surface conditions. ACI Mater J (2006) 103 (4): 233-242.
- L. T. Mammoliti, L. C. Brown, C. M. Hansson, B. B. Hope, The influence of surface finish of reinforcing steel and pH of the test solution on the chloride threshold concentration for corrosion initiation in synthetic pore solutions. Cem Concr Res (1996) 26 (4): 545-550. [https://doi.org/10.1016/0008-8846\(96\)00018-X](https://doi.org/10.1016/0008-8846(96)00018-X)
- L. Li, A. A. Sagüés, Chloride corrosion threshold of reinforcing steel in alkaline solutions - Open-circuit immersion tests. Corrosion (2001) 57 (1): 19-28. <https://doi.org/10.5006/1.3290325>
- M. Manera, Ø. Vennesland, L. Bertolini, Chloride threshold for rebar corrosion in concrete with addition of silica fume. Corros Sci (2008) 50 (2): 554-560. <https://doi.org/10.1016/j.corsci.2007.07.007>
- U. M. Angst, B. Elsener, Forecasting chloride-induced reinforcement corrosion in concrete - effect of realistic reinforcement steel surface conditions, Proc. 4th Int. Conf. on Concrete Repair, Rehabilitation and Retrofitting (ICCRRR), Leipzig, Germany, 2015. <https://doi.org/10.1201/b18972-26>
- A. T. Horne, I. G. Richardson, R. M. D. Brydson, Quantitative analysis of the microstructure of interfaces in steel reinforced concrete. Cem Concr Res (2007) 37 (12): 1613-1623. <https://doi.org/10.1016/j.cemconres.2007.08.026>
- A. Castel, T. Vidal, R. François, G. Arliguie, Influence of steel-concrete interface quality on reinforcement corrosion induced by chlorides. Mag Concr Res (2003) 55 (2): 151-159. <https://doi.org/10.1680/macr.2003.55.2.151>
- T. A. Soylev, R. François, Quality of steel-concrete interface and corrosion of reinforcing steel. Cem Concr Res (2003) 33 (9): 1407-1415. [https://doi.org/10.1016/S0008-8846\(03\)00087-5](https://doi.org/10.1016/S0008-8846(03)00087-5)
- U. Angst, Chloride induced reinforcement corrosion in concrete; concept of critical chloride content – methods and mechanisms. PhD thesis. Norwegian University of Science and Technology, NTNU. Trondheim, Norway, 2011.
- P. v. Nygaard, Effect of Steel-Concrete Interface Defects on the Chloride Threshold for Reinforcement Corrosion. MSc thesis. Denmark, 2003.
- P. Lambert, C. L. Page, P. R. W. Vassie, Investigations of reinforcement corrosion: Part 2 - Electrochemical monitoring of steel in chloride-contaminated concrete. Mater Struct (1991) 24 (143): 351-358. <https://doi.org/10.1007/BF02472068>
- U. M. Angst, B. Elsener, C. K. Larsen, Ø. Vennesland, Chloride induced reinforcement corrosion: Electrochemical monitoring of initiation stage and chloride threshold values. Corros Sci (2011) 53 (4): 1451-1464. <https://doi.org/10.1016/j.corsci.2011.01.025>
- G. T. Burstein, G. O. Ilevbare, The effect of specimen size on the measured pitting potential of stainless steel. Corros Sci (1996) 38 (12): 2257-2265. [https://doi.org/10.1016/S0010-938X\(97\)83146-0](https://doi.org/10.1016/S0010-938X(97)83146-0)
- L. Li, A. A. Sagüés, Chloride corrosion threshold of reinforcing steel in alkaline solutions - Effect of specimen size. Corrosion (2004) 60 (2): 195-202. <https://doi.org/10.5006/1.3287721>
- U. Angst, A. Rønquist, B. Elsener, C. K. Larsen, Ø. Vennesland, Probabilistic considerations on the effect of specimen size on the critical chloride content in reinforced concrete. Corros Sci (2011) 53 (1): 177-187. <https://doi.org/10.1016/j.corsci.2010.09.017>
- H. Arup, H. E. Sørensen, A proposed technique for determining chloride thresholds. Proc. Int. RILEM Workshop "Chloride penetration into concrete", Oct. 1995, Paris, France, (1997): 460-469.
- C. Alonso, M. Castellote, C. Andrade, Chloride threshold dependence of pitting potential of reinforcements. Electrochim Acta (2002) 47 (21): 3469-3481. [https://doi.org/10.1016/S0013-4686\(02\)00283-9](https://doi.org/10.1016/S0013-4686(02)00283-9)
- C. Andrade, Determination of the chloride threshold in concrete. In: R. Cigna, C. Andrade, U. Nürnberger, R. Polder, R. Weydert and E. Seitz (Eds.), COST Action 521, final report "Corrosion of steel in reinforced concrete structures" (2003): 101-111.
- D. Boubitsas, L. Tang, The influence of reinforcement steel surface condition on initiation of chloride induced corrosion. Mater Struct (2015) 48: 2641-2658. <https://doi.org/10.1617/s11527-014-0343-2>
- U. Angst, B. Elsener, C. K. Larsen, Ø. Vennesland, Chloride induced reinforcement corrosion: Rate limiting step of early pitting corrosion. Electrochim Acta (2011) 56 (17): 5877-5889. <https://doi.org/10.1016/j.electacta.2011.04.124>
- A. Pourbaix, Localized corrosion: behaviour and protection mechanisms, Proc. Proc. Conf. "Corrosion chemistry within pits, crevices and cracks", Teddington, Middlesex UK (1984):1-15.
- B. Reddy, G. K. Glass, P. J. Lim, N. R. Buenfeld, On the corrosion risk presented by chloride bound in concrete. Cement Concrete Comp (2002) 24 (1):1-5. [https://doi.org/10.1016/S0958-9465\(01\)00021-X](https://doi.org/10.1016/S0958-9465(01)00021-X)
- P. Vassie, Reinforcement corrosion and the durability of concrete bridges. Proc Inst Civ Eng Part 1 (1984) 76: 713-723.
- M. Stefanoni, U. Angst, B. Elsener, Local electrochemistry of reinforcement steel – distribution of open circuit and pitting potentials on steel with different surface condition, Corros Sci (2015) 98: 610 – 618. <https://doi.org/10.1016/j.corsci.2015.06.004>

-
- [30] M. Strattmann, J. Müller, The mechanism of the oxygen reduction or rust-covered metal substrates, *Corros Sci* (1994) 36: 327 - 359. [https://doi.org/10.1016/0010-938X\(94\)90161-9](https://doi.org/10.1016/0010-938X(94)90161-9)
- [31] U. M. Angst, M. R. Geiker, A. Michel, C. Gehlen, H. Wong, O. B. Isgor, B. Elsener, C. M. Hansson, R. François, K. Hornbostel, R. Polder, M. C. Alonso, M. Sanchez, M. J. Correia, M. Criado, A. Sagüés and N. Buenfeld, The steel-concrete interface. *Mater Struct* (2017) 50 (2): 143. <https://doi.org/10.1617/s11527-017-1010-1>
- [32] U. M. Angst, C. Boschmann, M. Wagner and B. Elsener, Experimental Protocol to Determine the Chloride Threshold Value for Corrosion in Samples Taken from Reinforced Concrete Structures. *J Visualized Exp* (2017) (126): e56229.