



## **Design for test and qualification through activity-based modelling in product architecture design**

Downloaded from: <https://research.chalmers.se>, 2026-04-05 09:15 UTC

Citation for the original published paper (version of record):

Borgue, O., Paissoni, C., Panarotto, M. et al (2021). Design for test and qualification through activity-based modelling in product architecture design. *Journal of Engineering Design*, 32(11): 646-670.  
<http://dx.doi.org/10.1080/09544828.2021.1950656>

N.B. When citing this work, cite the original published paper.



## Design for test and qualification through activity-based modelling in product architecture design

Olivia Borgue, Christopher Paissoni, Massimo Panarotto, Ola Isaksson, Tommaso Andreussi & Nicole Viola

To cite this article: Olivia Borgue, Christopher Paissoni, Massimo Panarotto, Ola Isaksson, Tommaso Andreussi & Nicole Viola (2021): Design for test and qualification through activity-based modelling in product architecture design, Journal of Engineering Design, DOI: [10.1080/09544828.2021.1950656](https://doi.org/10.1080/09544828.2021.1950656)

To link to this article: <https://doi.org/10.1080/09544828.2021.1950656>



© 2021 The Author(s). Published by Informa UK Limited, trading as Taylor & Francis Group



Published online: 16 Jul 2021.



Submit your article to this journal [↗](#)



Article views: 77





View related articles [↗](#)



View Crossmark data [↗](#)

## Design for test and qualification through activity-based modelling in product architecture design

Olivia Borgue <sup>a</sup>, Christopher Paissoni <sup>b</sup>, Massimo Panarotto <sup>a</sup>, Ola Isaksson <sup>a</sup>, Tommaso Andreussi<sup>c</sup> and Nicole Viola<sup>b</sup>

<sup>a</sup>Industrial and Materials Science, Chalmers University of Technology Göteborg, Gothenburg, Sweden;

<sup>b</sup>Mechanics and Aerospace Engineering (DIMEAS), University of Turin and Polytechnic of Turin Centre for Research on Studies in Europe and in the Mediterranean, Turin, Italy; <sup>c</sup>Space Systems, SITAEL SpA, Ospedaletto, Italy

### ABSTRACT

Test and qualification (T&Q) phases take a significant portion of the time to market for critical products in the space industry, especially when introducing new technologies. Since T&Q are treated as standard procedures, they tend to be independent of the architectural design phases and kept away from design decisions. However, when introducing new technologies, qualification procedures may differ from those established in regular design scenarios, and the estimation of qualification costs and duration is problematic. There is a lack of design for qualification methods capable of modelling these activities in early phases and use those models to support the architecture design of products with affordable test and qualification phases. In this article, a computer-assisted, model-based design method to model T&Q activities concerning early product architecture designs is proposed. Product architecture alternatives, test schedules and cost are connected through the quantification of T&Q drivers and driver rates. The design method is demonstrated using a case study about electric propulsion for satellites. The method is applicable for design situations where the choice of technology has a strong dependence on the qualification procedure.

### ARTICLE HISTORY

Received 10 February 2020  
Accepted 29 June 2021

### KEYWORDS

Qualification; space industry; model-based design; product architecture

## 1. Introduction

To remain competitive in the market, companies strive to introduce new technologies to increase product performance and reduce costs and time to market. These technologies often introduce changes in the product's architecture, which is defined as the product's basic physical building blocks and their interactions (Ulrich and Eppinger 2015).

Research has shown that designers are prone to developing product architectures that maximise the implementation and benefits of new technology based on performance, functionality and projected product cost (Wyatt, Eckert, and Clarkson 2009; Borgue, Panarotto, and Isaksson 2019). Consequently, they risk missing to include the impact that the integration of new technologies may bring onto the realisation process (Tatikonda and

**CONTACT** Olivia Borgue  borgue@chalmers.se  Industrial and Materials Science, Chalmers University of Technology Göteborg Gothenburg, Sweden

© 2021 The Author(s). Published by Informa UK Limited, trading as Taylor & Francis Group

This is an Open Access article distributed under the terms of the Creative Commons Attribution-NonCommercial-NoDerivatives License (<http://creativecommons.org/licenses/by-nc-nd/4.0/>), which permits non-commercial re-use, distribution, and reproduction in any medium, provided the original work is properly cited, and is not altered, transformed, or built upon in any way.

Rosenthal 2000). This tendency is also present in high-cost, high-reliability industries, such as the space industry, where established realisation processes have evolved through deep knowledge of the behaviour of the technologies utilised.

In recent years, there has been an increase in the demand for access to space, with new actors competing for market shares. Market developers now expect leaps in cost decrease and time to market while maintaining high reliability (Öhrwall Rönnbäck and Isaksson 2018). Incentives to introduce novel and high-potential technologies and manufacturing techniques are high.

However, the rigorous processes required to test and qualify new technologies extend the actual lead time for testing procedures, and due to the uncertainty of their outcome, there is a risk of long design iterations (Engel and Barad 2003; Dordlofva et al. 2019). Moreover, as qualification procedures for new technologies can differ from those standardised for regular design scenarios, test phases may further increase costs and redesign iterations (Dordlofva et al. 2019). Therefore, the ability to account for qualification procedures in early design phases has become increasingly important.

The early consideration of qualification requirements, through design for qualification (DfQ) strategies, would support the design of architectures with affordable test and qualification phases and reduce redesign iterations (Wang, Azarian, and Pecht 2008; Dordlofva et al. 2019), reducing the duration and cost of the product development process (PDP) as well. Once the product architecture is successfully implemented, the designer can choose between optimising its performance and reducing the cost of realisation, where test and qualification activities play an important part.

A well-known limitation for early design assessment of test and qualification activities is the lack of model-based methods (methods based on the implementation of models) to estimate the duration and cost of these activities (Tahera et al. 2019). Therefore, this study aims at answering the following research question:

How can qualification activities be modelled during preliminary design to support design efforts and reduce future redesign iterations?

This article aims to propose a method for modelling test and qualification activities that enables designers to include unique requirements stemming from test and qualification (T&Q) of new technologies when exploring alternative product architectures. A case study from a technology-development project at a satellite space propulsion manufacturer serves to illustrate this method.

## 2. Background

### 2.1. Test and qualification activities in the product design and development process

Test activities are performed throughout the PDP to attain different objectives, from concept development to detailed design (Tahera and Earl 2018). Among test activities, qualification activities are performed to demonstrate that a product meets specified safety and legislative norms and quality and reliability requirements (ISO 2020). Similar objectives can be attributed to the verification, validation and testing (VVT) activities in the systems engineering field (Shabi, Reich, and Diamant 2017). VVT activities are performed throughout a PDP before delivering or marketing products for ensuring product quality. Verification is

most often used to test the fulfilment of requirements, whereas validation activities test the fulfilment of stakeholders' needs and expectations. The ISO/IEC/IEEE 12207-2:2020(E) standard draws a clear parallel between verification and qualification activities (ISO 2020).

Design development and test activities are performed iteratively throughout the PDP. Data obtained from test activities can be expensive both in terms of cost and time. For this reason, how and when these data are used is critical, as it can impact the cost and duration of the product development activities.

In their review of the modelling of test activities, Tahera et al. (2019) argue that most modelling methods focus on the schedule of a given set of design and test activities to optimise development times. Other studies are concerned with choosing the most appropriate test activities in terms of cost and risk.

Engel and Barad (2003) and Tahera et al. (2019) indicate that the cost of test activities can be as much as 55% of the total life cycle cost. Moreover, test activities depend on product architectures and design contexts; therefore, they should be adapted to different product architecture scenarios (Wang, Azarian, and Pecht 2008).

However, the reviewed literature does not provide mechanisms to enhance the conceptual design phases with insights (or requirements) from the T&Q phases. There seems to be an underlying assumption that there is enough upfront information about the technologies considered, the product itself, as well as how the T&Q of these technologies can be conducted. However, when introducing new technologies, information about product design and the corresponding T&Q activities may not be available. Consequently, test phases can result in unexpected costs or difficulties that lead to expensive redesign iterations (Wang, Azarian, and Pecht 2008; Dordlofva et al. 2019).

## **2.2. Modelling test activities to support DfQ in early design phases**

To model T&Q activities and connect them to product architecture requirements, the factors or variables that influence the cost and duration of these activities must be first identified. In this article, those factors are referred to as T&Q drivers.

The notion of a *driver* is used in literature to describe the causes that affect the output of a system. The term – in this case, *cost driver* – is usually implemented when referring to factors that cause a change in cost (Shank 1989). Authors such as Ben-Arieh and Qian (2003), for instance, developed a parametric cost-estimation model for modelling costs of manufacturing activities using cost drivers of machined parts; the authors identified activity cost drivers (ACD) for the manufacturing processes. For each ACD, they defined activity cost driver rates (ACDR) as the total activity cost divided by the number of cost drivers. Their cost model allows for modelling the costs of manufacturing activities in the early design and development phases.

However, as authors such as Shabi, Reich, and Diamant (2017) and Tahera et al. (2019) point out, the identification of activity drivers and the consequent model of test activities have received significantly less attention in the research community in comparison with other design and analysis activities in a PDP.

Some authors, such as Wyatt, Eckert, and Clarkson (2009) and Tahera et al. (2019), mention that design complexity, product architecture, degree of novelty, the timing of testing and susceptibility to design change affect the duration and cost of test activities. Moreover, when redesigning or upgrading a product, companies attempt to limit the implementation

of new components as they increase test activities. These factors are identified as test drivers. These studies, however, do not present a clear statement about the extent to which those drivers affect test activities or how test activities can be modelled and linked to product architecture. Similar insights about VVT activities can be found in literature, for example, in the work by Shabi, Reich, and Diamant (2017). However, the relationship between VVT drivers and product architecture is not established directly.

Dordlofva et al. (2019) presented a compendium of qualification drivers extracted from manufacturers of space components but did not explain further their influence on product architecture design or selection. There is a need for DfQ methods that connect product architecture design phases to T&Q activities; this connection can be achieved by modelling T&Q activities. The main contribution of this article is a model-based design for the qualification method to link T&Q activities to early design phases through the identification of T&Q drivers.

### 3. Research methodology

A case where qualification has a direct impact on the selection of new technologies and the concept selection for new products was identified within an advanced manufacturing demonstration project for next-generation satellite-propulsion systems. The project is part of Horizon 2020, funded by the European Commission, with the objective of developing three different electric propulsion subsystems.

This article is focused on developing a T&Q model and its implementation during the conceptual design phases of an electric propulsion system (EPS). The study focused on conventional EPS architectures, implementing a power-processing unit (PPU), and innovative EPS architectures, implementing a direct drive (DD) technology (Impresario 2015).

The core of the data collection activities for this study was performed during a three-month visit to a satellite manufacturer participating in the project. During this period, the first and second authors worked on site in collaboration with the EPS design team. Full access to real company data and the possibility to perform interviews and participate in their technical meetings were provided. The second author already worked at the company in a supporting role for mission analysis. The first author had the role of an observer to gather data during the study. The authors invested the equivalent of 60 full working days (8hs/day) in the data collection activities of this study.

The information gathered can be divided into (1) information gathered from documented sources (documented information) and (2) information gathered through interactions with practitioners (tacit information). Information-gathering activities are detailed in Sections 3.1 and 3.2.

From the study, a generic method for modelling T&Q activities and including them in early design phases was developed. The method aimed at supporting architectural design decisions and developing products with affordable T&Q phases. The method was applied for the design of a high-power propulsion system for space exploration.

The performed activities are schematised in Figure 1 and hereby presented.

#### 3.1. Data collection of documented information

The data collection of documented information was performed through the analysis of the company's internal documentation, including mission-specific (where and how the

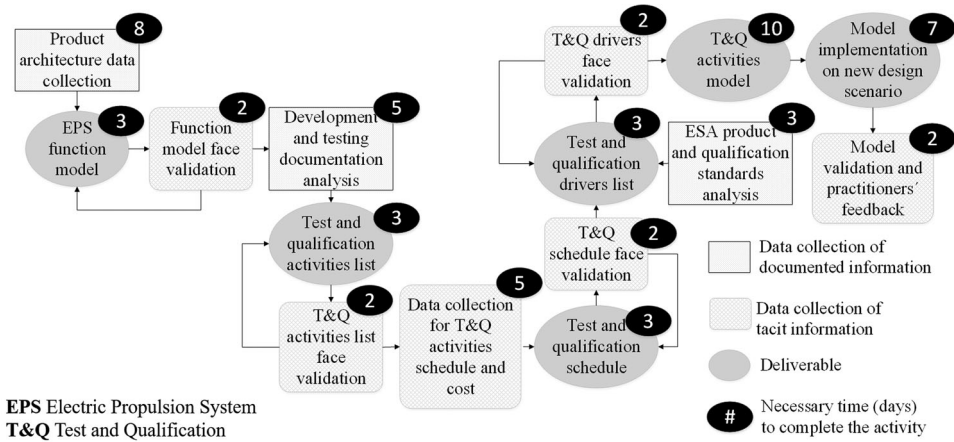

**Figure 1.** Research methodology diagram illustrating the performed data collection activities and time for activity completion.

product was going to be utilised) and product-specific (design and test requirements to comply with the specific mission) documents. As presented in Figure 1, the first data collected were stored in a function-means model of the EPS (Claesson 2006). A function model was preferred, as it facilitates product architecture understanding and the establishment of system boundaries (Müller, Siiskonen, and Malmqvist 2020), assessing the components, subsystems and interactions that were going to be included in the study.

Later, documentation about product development and testing was gathered and documented in preliminary lists. Those lists and further information collected about activity schedules were later stored in Gantt and PERT (Program evaluation and review technique) charts.

Finally, another portion of the data was obtained from the ESA’s product and T&Q standards for space components, such as ECSS-Q-ST-70-45C for mechanical testing of metallic materials (ECSS 2008), or ECSS-Q-ST-60C Rev.2 for electrical, electronic and electromechanical components (ECSS 2013). This documentation supported the identification and analysis of the drivers that motivate the implementation, cost and duration of T&Q activities.

### 3.2. Data collection of tacit information

In addition to the collection of documented information, a series of meetings and semi-structured interviews with company practitioners was performed. As presented in Figure 1, most of the meetings were held to validate 1) the EPS function model, 2) the T&Q list, 3) the T&Q schedule, 4) the T&Q drivers, and 5) the T&Q activities models.

Semi-structured interviews were held to gather information about the best-, average- and worst-case scenario for activity cost and duration. Moreover, the interviewees were requested to provide information about the activities’ sequences. Data obtained from different participants and documented information were compared, and when discrepancies were found, additional meetings were held. The meetings and interviews for the data collection of tacit information were held with seven company practitioners, with an average

of 10 years of expertise in the areas of systems engineering, design and T&Q of EPS. Each meeting lasted between one and two hours.

During the interviews, practitioners were also asked about the factors that influence the cost (cost drivers) and duration (duration drivers) of T&Q activities. However, the information gathered about cost and duration was further analysed to find commonalities and trends among activities and their relation to architectural components. This analysis was performed to find cost and duration drivers not mentioned by the practitioners.

The performed data collection and study led to the development of the method proposed in this article for modelling T&Q activities and its implementation to support product architecture design decisions. The proposed method is introduced in the following section.

#### **4. Modelling T&Q activities for supporting architecture design decisions**

This section presents a DfQ method and its implementation to support product architecture design decisions. The method is based on identifying the factors that drive (drivers) duration and cost of T&Q activities and their interaction with activity schedules.

The input of this method is the current product design information, such as CAD files, datasheets, etc., and the T&Q activities related to it, such as development and testing documentation. The outputs of this method are the total cost and duration of T&Q phases and a T&Q model, which can then be implemented to estimate the duration and cost of the T&Q activities for future product architectures. The T&Q model and the cost and duration of each T&Q activity are used to support the design of product architectures with affordable T&Q phases.

To support design decisions, the DfQ method combines function-modelling techniques, which support the decomposition and visualisation of alternative product architectures, with the identification and quantification of T&Q drivers to model T&Q activities.

Figure 2 presents the proposed method, which can be divided into six steps presented in the following sections.

##### **4.1. Step 1: construct function model**

With information about product architecture and design, a function model of the product is constructed. Function models are representations of the hierarchical decomposition of a product's functional requirements (Claesson 2006). In this article, the function-modelling technique preferred is enhanced function-means (EF-M), which associates one design solution (DS) with each functional requirement (FR) (Claesson 2006; Müller, Siiskonen, and Malmqvist 2020), as presented in Figure 3, left. Interactions between the DSs can be modelled using "interacts with" connections. Such interactions can be of four types: geometry, signals, energy, and material flow. In this article, DSs are used to represent components or component assemblies.

##### **4.2. Step 2: construct PERT diagram**

In this step, PERT diagrams are constructed (Dodin 1985). These representations facilitate the understanding of the T&Q workflow and are necessary for performing a calculation of the total duration of T&Q activities.

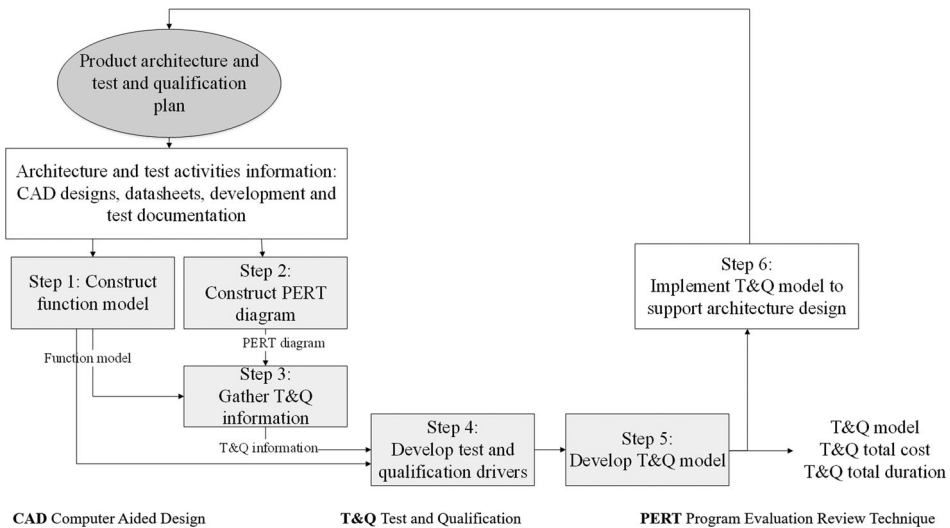

**Figure 2.** Process diagram of the design for qualification method.

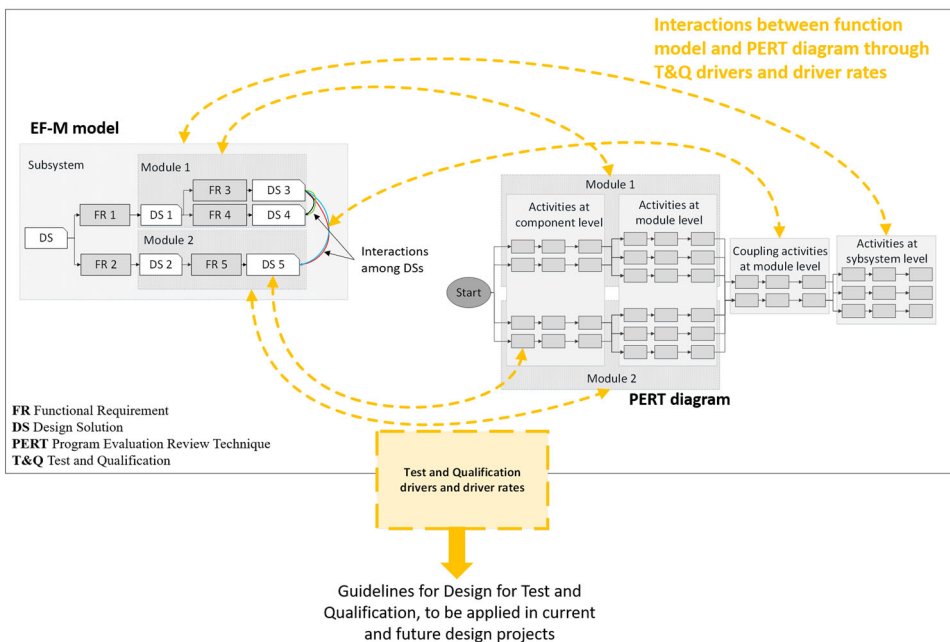

**Figure 3.** EF-M (Enhanced Function-Means) elements representing a product architecture (left) and activities performed for testing and qualifying such architecture (right). Their connection through test and qualification (T&Q) drivers enables the proposed design for qualification method.

Using the function model as a visual guideline of product architecture, T&Q activities should be grouped according to the system level they belong to (system, subsystem, module or component level). Generally, every activity in the PERT diagram must have a corresponding element in the product architecture; however, several activities can share the

same element. The function model, in this case, provides a structure for T&Q activity identification, as it can depict interfaces among components or subsystems, interfaces which are often tested, as highlighted with dashed arrows in Figure 3.

#### **4.3. Step 3: gather T&Q activities' information**

Step 3 concerns gathering information about the duration and cost of T&Q activities. The duration and cost of each activity are represented by a beta probability distribution function (PDF). In a beta probability function, the area under the curve on the right side of the most likely activity completion time is greater than the area on the left side, representing the human tendency to extend the duration of a task to fill the available completion time (Browning and Eppinger 2002). In this article, however, the beta representation is estimated by a triangular distribution, using three values for activity duration: best-case, most likely, and worst-case scenario durations. The height of a triangle distribution (the most likely activity duration) is normalised; therefore, the area under the distribution equals one. This estimation has been extensively implemented by authors such as Browning and Eppinger (2002) or Wu (2016).

Step 3 is focused on details for breaking down cost and duration information. For example, if 20 h are required to test electronic equipment, the duration breakdown may include a list of every test performed, their duration and sequence (which, in the end, will add up to 20 h). A cost breakdown would include information about necessary resources for the tests, such as the number of engineers or technicians, equipment implemented and consumables.

The information gathered in this step enables the construction of a Gantt chart of the T&Q activities, which facilitates the assessment of schedule and activity duration by practitioners (Wilson 2003).

#### **4.4. Step 4: develop T&Q drivers**

In Step 4, T&Q drivers are identified by analysing the data obtained in the previous steps.

After their identification, activity driver rates for each driver are established. In research conducted by Ben-Arieh and Qian (2003), the authors identified ACDs and their respective ACDRs for manufacturing processes.

For example, the authors determined that the activity "Discuss product (manufacturing)" had a total cost of \$17.53. After performing a cost breakdown, it was found that such cost was driven by the "Number of tool changes", which in their case was equal to six (six tool changes were performed). Therefore, the activity cost driver rate for the driver Number of tool changes is  $\$17.53 / 6 = \$2.91$ .

In Step 4, ACD and ACDR are identified for each T&Q activity. Moreover, following the logic behind the definition of ACD and ACDR, activity duration drivers (ADD) and their respective activity duration driver rates (ADDR) are identified as well. The identification of ADD and ADDR enables the assessment of T&Q activities' duration in early design phases.

#### **4.5. Step 5: develop T&Q model**

By implementing the T&Q drivers and their respective driver rates, the duration and cost of such activities can be modelled in relation to the product's architectural features. As

Ben-Arieh and Qian (2003) have previously proposed, the cost of a manufacturing process defined by ACDs and ACDRs can be modelled as  $\sum_{i=1} ACD_i \times ACDR_i$ . The same principle can be implemented to model the duration and cost of T&Q activities once ACDs and ACDRs are identified. Then, implementing the PERT diagram from Step 2, the total cost and duration of the T&Q phase are obtained through an activity network calculation code that reduces the whole activity schedule to one equivalent activity, as proposed by Dodin (1985).

#### 4.6. Step 6: implement T&Q model to support architectural design

The developed T&Q model is implemented to support architectural design and selection in early design phases (bottom of Figure 3).

### 5. Applying the DfQ method on a high-power EPS design

The proposed DfQ method is illustrated with the analysis of an already developed 5 kW hall thruster (HT) EPS. The analysis performed on this thruster enables the development of T&Q models to support the development of a future high-power (20 kW) HT EPS architecture.

A conventional EPS for an HT comprises a PPU, a fluid management system (FMS) and a thruster unit (TU), which comprises a thruster and a cathode. A conventional EPS architecture is presented in Figure 4. The EPS is fed by the satellite's power-generation system (PGS), consisting of solar arrays (SA), a power bus and batteries. The PPU modulates the power from the power bus, controls the operation of the subsystem components and provides housekeeping telemetries.

Thrust is generated and sustained by the TU and cathode, ionising propellant, typically xenon, provided by the FMS. The ionised propellant (plume) is accelerated with a magnetic field, propelling the satellite (Impresario 2015).

To ensure compliance with quality requirements, different tests are performed at component, module and subsystem levels. Some tests include mechanical tests, such as vibration and shock tests, and vacuum tests, performed in an adequate vacuum environment with high pumping capabilities (ECSS 2018). The long duration and high costs of these tests constrain the product development schedule.

Through each development and test step, different physical thruster models are implemented following the ECSS standards (ECSS 2018). These models include (1) an engineering model (EM), representative in terms of fit, functionality and form, (2) an engineering qualification model (EQM), which fully respects the final product excepts for standard parts, (3) a proto-flight model (PFM), representing the end product during the qualification tests, and (4) a flight model (FM) as the end product before the acceptance phase.

With the development of increasingly powerful HTs, system complexity and mass may increase.

The main drawbacks of EPSs with conventional PPU arrangement are heavyweight and large volume. A solution can be a direct-drive architecture, with power from the SAs directly transferred to the TU, simplifying the PPU with the removal of the power modules for the operations of the TU and cathode (Impresario 2015).

However, when implementing a DD architecture, the power bus must be designed to sustain the high-voltage levels of the TU. Moreover, the rest of the components of the PGS

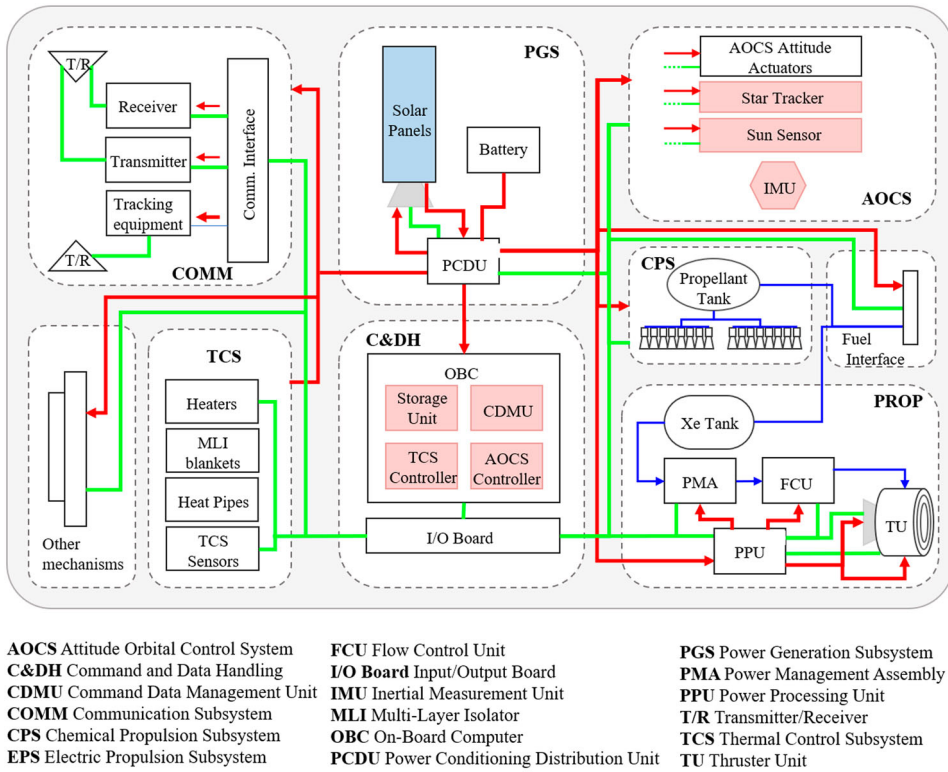

**Figure 4.** Satellite system architecture.

shall be adapted to cope with high-voltage levels, relying (in some architectural solutions) on high-voltage SAs. However, an inconvenience of such SAs is the risk associated with arcing and the interaction of the SA with the TU plume. These events require additional T&Q activities (Impresario 2015).

To assess the duration and cost of T&Q activities for a 20 kW HT and implement these insights for making architectural design decisions, a T&Q model for known HT architectures is developed in section 5.1, following the method introduced in section 4. In section 5.2, the model is implemented to support the conceptual design of a 20 kW HT.

### 5.1. Development of a T&Q model for a 5 kW HT

Following step 1, CAD designs, datasheets and other product architecture data were used to build a function model of the 5 kW HT. Figure 5 illustrates a simplified version of such a model. The model alternates functions with DSs and represents interfaces among components and modules (coloured lines). The work done by Claesson (2006) offers a detailed explanation of the theory and methods for building an EF-M.

From the information gathered about T&Q activities, the PERT diagram presented in Figure 6 was built. In this case, the PPU, the FMS and the TU are different modules of the EPS. Therefore, the EPS and the PGS are subsystems of the satellite system.

In general, the process of building the PERT and function models is iterative. A common complaint about EF-M modelling is the lack of modelling guidelines on what to

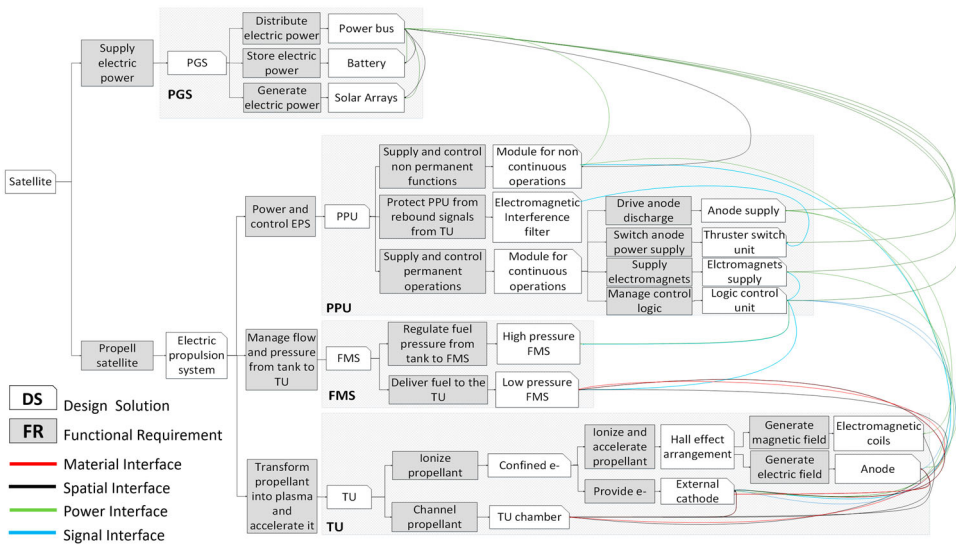

Figure 5. Simplified function model of a hall thruster.

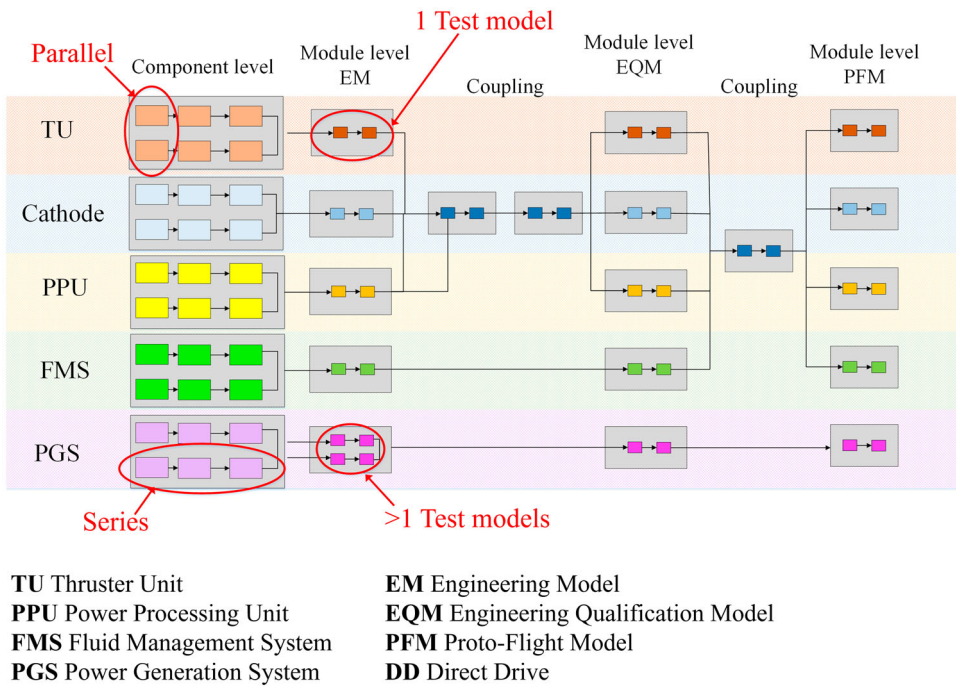

Figure 6. PERT diagram with a simplified representation of the test and qualification activities. Different EPS modules and the PGS are identified with different colours: orange (TU), blue (Cathode), yellow (PPU), green (FMS) and pink (PGS).

include in the model and how (Müller, Siiskonen, and Malmqvist 2020). As every activity in the PERT diagram must have a corresponding element in the product architecture, iterating between the PERT and function models helps in building a complete function model without unnecessary details. Moreover, information from CAD designs and datasheets can

evidence elements in the function model without a corresponding test activity. In this case, further efforts to find information about those test activities and include them in the PERT diagram should be made.

In the PERT diagram, testing activities related to single components from the different product modules (such as PPU, FMS, TU and cathode) are performed in series with other activities from the same module but in parallel to activities performed on the other modules. Later, at the module level and EPS subsystem level, testing activities can be performed either in series or in parallel. The choice depends on the implementation of one or more test models (EM, EQM and PFM), as the latter option allows for several activities to be performed in parallel. Figure 6 includes the PGS as well. The PGS is presented in a general way, not distinguishing its modules and components to reduce figure complexity, presenting, however, the T&Q activities performed to evaluate its interaction with the EPS.

Table 1 presents a compendium of the duration and cost of T&Q activities performed at the component level. The details of those activities are not included in the table to preserve company-sensitive information.

Table 2 presents a simplification of the activities performed on different test models (EM, EQM or PFM) for the different EPS modules and PGSs. Only representative activity placeholders were included; this simplification preserves company-sensitive information while supporting the presentation of the proposed T&Q activities model. For the same reason, activity durations and cost values are not representative of the real company data.

From Tables 1 and 2, T&Q duration and cost drivers can be extracted. However, some of the drivers do not depend on the EPS design. This is the case for the duration of the module level tests, which are determined by the satellite mission and standardised test configurations, such as the ECSS-Q-ST-70-45C for mechanical testing of metallic materials (ECSS 2008), or the ECSS-Q-ST-60C Rev.2 for electrical, electronic and electromechanical components (ECSS 2013).

Similar to the procedure followed by Ben-Arieh and Qian (2003) and introduced in Section 4.4, design-dependent driver rates were obtained from the activities in Tables 1 and 2. Some of the driver rates are presented in Tables 3 and 4.

**Table 1.** Data collected for components in the PPU, FMS and TU modules.

Component	Duration (days)			Cost (euros)			Cost remarks	Duration remarks
	B	M	W	B	M	W		
<b>PPU</b>								
Components without firmware	12	22	35	264	484	770	1 engineer. Proportional to time	Firmware increases duration.
Components with firmware	18	30	45	396	660	990		
<b>FMS</b>								
Mechanic components	6	11	17	110	220	330	New materials, coatings, manufacturing techniques or design geometries increase duration	
Electronic components	12	22	35	264	484	770		
<b>TU</b>								
Electromagnets comp.	6	11	17	110	220	330	Proportional to testing time. Average of 1.5 engineers.	
Anode	10	14	18	220	308	396		
Electromagnet assembly	1	2	4	22	44	88		
<b>PGM</b>								
Electrical components	12	22	35	264	848	770	Proportional to time. 1 engineer	Depends on SA voltage.

**Table 2.** Data collected for module level.

Cathode	Duration (days)			Cost (x10 <sup>2</sup> €)			Cost remarks	Duration remarks
	B	M	W	B	M	W		
Tests at EM level	200	340	520	18000	30000	46000	2 engineers. Depends on type of propellant and thruster power. Proportional to time.	Depends on test configuration and satellite mission.
Tests at EQM level	200	340	520	19000	31000	47000		
Tests at PFM level	200	340	520	19000	31000	47000		
<b>FMS</b>								
Tests at EM level	16	24	40	180	185	195		
Tests at EQM level	40	70	100	250	255	265		
Tests at PFM level	16	24	40	740	750	770		
<b>TU</b>								
Tests at EM level	140	300	40	4600	5100	5400	2 engineers. Depends on type of propellant, vacuum chamber and number of models tested. Thruster power increases costs. Proportional to time.	
Tests at EQM level	70	100	140	5100	7300	10000		
Tests at PFM level	60	90	120	4400	6600	8800		
<b>PPU</b>								
Tests at EM level	140	300	400	650	690	710	1 engineer. Proportional to time	
Tests at EQM level	70	100	140	2000	21000	23000		
Tests at PFM level	60	90	120	2000	21000	23000		
<b>Other</b>								
Coupling tests	40	60	120	10	14	30	2 engineers	
<b>PGS</b>								
Tests at EM level	140	300	400	900	1200	1500	2 engineers. Proportional to time.	Duration of the electro discharge test depend on voltage level.
Tests at EQM level	70	100	140	2000	2100	2200		
Tests at PFM level	60	90	120	3800	3900	4000		

For example, Table 1 indicates that T&Q activities for PPU components without firmware have a duration of (12, 22, 35) days, and components with firmware have a duration of (18, 30, 45) days. Every PPU component requires at least (12, 22, 35) T&Q days; hence, the number of PPU components (Nmp) is a qualification driver and (12, 22, 35) days/Nmp is its driver rate. PPU components with firmware (Nmf) require (6, 8, 10) extra T&Q days; hence, Nmf is a qualification driver with the driver rate of (6, 8, 10) days/Nmf.

Activity cost drivers that depend on activity duration drivers are not included in Table 4. For example, the number of PPU modules increases the duration of test activities, thereby increasing costs due to an increase in required manpower. However, the number of PPU modules is not considered a cost driver.

In Table 2, the cost and duration of the test activities on the module level depend on the number of models (EM, EQM or PFM) tested. If the number of models tested increases, cost increases as more test models are manufactured; however, the total duration of T&Q activities performed in a module is reduced, as several tests can be performed in parallel. In Table 3, the number of modules tested (Nemd, Nqmd and Npmd) can vary from one to the total number of T&Q activities performed. If the number of PPU EMs is one (Nem = 1), every test activity at the PPU EM level is performed in series. However, if the number of PPU EMs is equal to the number of test activities, every activity is performed in parallel.

From the data collected in previous steps, a T&Q dependency structure matrix (DSM) was built (Maheswari and Varghese 2005), as presented in Figure 7, top.

In the matrix, columns and rows represent test activities. Nondiagonal matrix components indicate that an activity in a certain row is dependent on the results from a previous

**Table 3.** Driver rates for activity duration drivers. Duration is presented in days.

		Activity duration drivers			
		Driver rate (days / N of driver)			
Activity	Driver	B	M	W	
PPU components test	Nmp	Number of components	12	22	35
	Nmf	Number of components with firmware	6	8	10
PGS components test	Nbu	Number of buses tested	12	22	35
	Nb	Number of batteries tested	12	22	35
	Ncon	Number of converters tested	12	22	35
	Vsa	SA voltage	(Vsa/100)B	(Vsa/100)M	(Vsa/100)W
	Nsa	Number of components on the SA	12	22	35
TU components tests	Nn#	Materials, coating, manufacturing technique or design geometry not implemented in previous projects	*B/(2Nn)	*M/(2Nn)	*W/(2Nn)
	Nc	Number of coils tested	0.5	1	2
	Ne	Number of electromagnets assemblies tested	1	2	4
	Nfe	Number of ferromagnetic parts tested	5	10	15
	Na	Number of anodes tested	10	14	18
FMS	Nfmc	Number of mechanical components	6	11	17
	Nfec	Number of electronic components	12	22	35
Tests at component level	Neg	Number of engineers	(1 < Neg < Number of tests)		
Coupling tests	Nct	Number of coupling tests	40	60	120
All tests on module level	Nem	Number of EM tested	1 < N#m < Number of tests		
	Nqm	Number of EQM tested			
	Npm	Number of PFM tested			

\*The driver rate equals a proportion of the test activity. For example, if the anode is manufactured with new manufacturing technologies (such as additive manufacturing), test activities are increased in a 50%.

#Nn# can represent Nnc (coils), Nne (electromagnet), Nnfe (ferromagnetic) and Nna (anode).

activity (or activities). If activity A depends on the results of activity B, A and B are in series, and their durations are added to compute the total T&Q duration. If activities A and B depend on the results of the same activity and their results are necessary for the execution of another activity, A and B are in parallel (Dodin 1985). In this case, only the duration of the longest activity is added to the total. In this way, the DSM is simplified until an equivalent single activity is reached (Figure 7, bottom). When the DSM becomes irreducible, duplication techniques are implemented, as suggested by Dodin (1985).

The DSM presents information in the same way a PERT diagram does; however, it has a better performance in schedule optimisation since it can allow operations such as sequencing or partitioning and tearing (Maheswari and Varghese 2005).

In the DSM, it is assumed that the test activities performed at the PPU component level are performed in series; however, they are performed in parallel to the tests performed at the TU component level. In the same way, only one model (one EM, one EQM and one PFM) is used at the module level. For instance, tests at the PPU module level are performed in series; however, they are performed in parallel to the tests performed at the TU module level.

The main contribution of this article is not the development of an algorithm for activity network calculation. Consequently, to simplify the duration and cost calculations, the activity model assumes that (1) activity durations are independent of each other: Dependencies are only accounted for in the interactions between the activities, and (2) activity duration accounts for any internal rework efforts.

**Table 4.** Driver rates for activity cost drivers. Duration is presented in days.

Activity cost driver			
Activity		Driver	Driver rate (euros / N of driver)
All activities	Neg	Number of engineers	22 per hs (Worldsalaries 2019)
	Npeb	Number of EM	50 K(1 + 0.1(Power-5 kW))
	Npeq	Number of EQM	250 K(1 + 0.1(Power-5 kW))
PPU	Npp	Number of PFM	250 K(1 + 0.1(Power-5 kW))
	Ncem	Number of EM	10 K(1 + 0.1(Power-5 kW))
	Nceq	Number of EQM	20 K(1 + 0.1(Power-5 kW))
	Ncp	Number of FPM	20 K(1 + 0.1(Power-5 kW))
	Tp	Thruster power	** (22Duration) 76 × 10 <sup>-5</sup>
Cathode	Nfem	Number of EM	75 K(1 + 0.1(Power-5 kW))
	Nfeq	Number of EQM	300 K(1 + 0.1(Power-5 kW))
	Nfp	Number of FPM	300 K(1 + 0.1(Power-5 kW))
FMS	Ntem	Number of EM	40 K(1 + 0.1(Power-5 kW))
	Nteq	Number of EQM	80 K(1 + 0.1(Power-5 kW))
	Ntp	Number of FPM	80 K(1 + 0.1(Power-5 kW))
TU	Tp	Thruster power	** (220Duration) 76 × 10 <sup>-5</sup>
	Ngem	Number of EM	10 K(1 + 0.1(Power-5 kW))
	Ngeq	Number of EQM	30 K(1 + 0.1(Power-5 kW))
PGS	Ngp	Number of FPM	30 K(1 + 0.1(Power-5 kW))

\*\* For Xenon, 760 euros/kg.

Consequently, the most probable total duration and cost of the T&Q activities for the 5 kW EPS are 1,340 days and €64,000,000. These results resonated well with company practitioners.

### Modelling T&Q activities

Based on the work presented by Ben-Arieh and Qian (2003), the duration and cost of the T&Q activities can be estimated using drivers and driver rates as

$$Activity\ duration = \sum_{i=1} ADD_i \times ADDR_i \quad (1)$$

$$Activity\ cost = \sum_{i=1} ACD_i \times ACDR_i \quad (2)$$

In these equations, activity duration and cost are represented by a vector of three components, namely, best-case-, most-probable-case- and worst-case-scenario duration and cost. The analysis was performed assuming that one test model (one EM, one EQM and one PFM) is used. (Tests are performed in series).

For example, the modelling equations for the total duration (equation 3) and cost (equation 4) for activities at a PPU component level are presented below. The rest of the modelling equations can be obtained through equations 1 and 2, after implementing the drivers and driver rates from Tables 3 and 4.

$$DPPU_{comp} = N_{mp}(12, 22, 35) + N_{mf}(6, 8, 10) \quad (3)$$

$$CPPU_{comp} = N_{eg} \times 22 \times DPPU_{comp} \quad (4)$$

Where T&Q activity durations:

- $N_{mp}$ : (ADD) Number of PPU components
- $N_{mf}$ : (ADD) Number of components with firmware

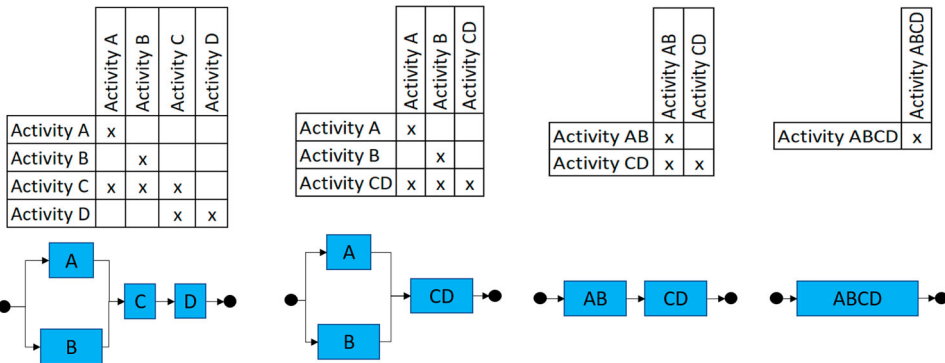
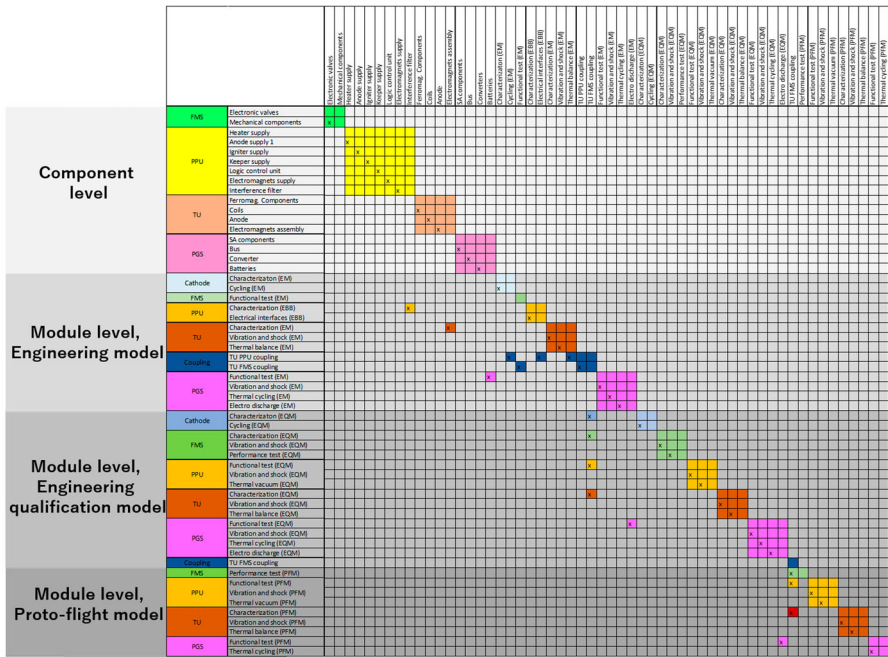

**Figure 7.** T&Q DSM (top) and operations performed to calculate the total duration of the T&Q phase (bottom). Different EPS modules and the PGS are identified with different colours: orange (TU), blue (Cathode), yellow (PPU), green (FMS) and pink (PGS).

- (12,22,35): Best-case-, most-probable-case- and worst-case-scenario ADDR for Nmp
- (6,8,10): Best-case-, most-probable-case and worst-case-scenario ADDR for Nmfi
- T&Q activities cost:
- $N_{eg}$ : (ACD) Number of engineers
- 22 (euros/hrs): engineer’s salary (Worldsalaries 2019)

**5.2. Application of the T&Q model for architectural design of a 20 kW HT**

In this section, the developed T&Q model is implemented to analyse the impact of different product architectures on the duration and cost of T&Q activities and support the development of additional architectures. Five different architectures of a 20 kW HT are analysed. The

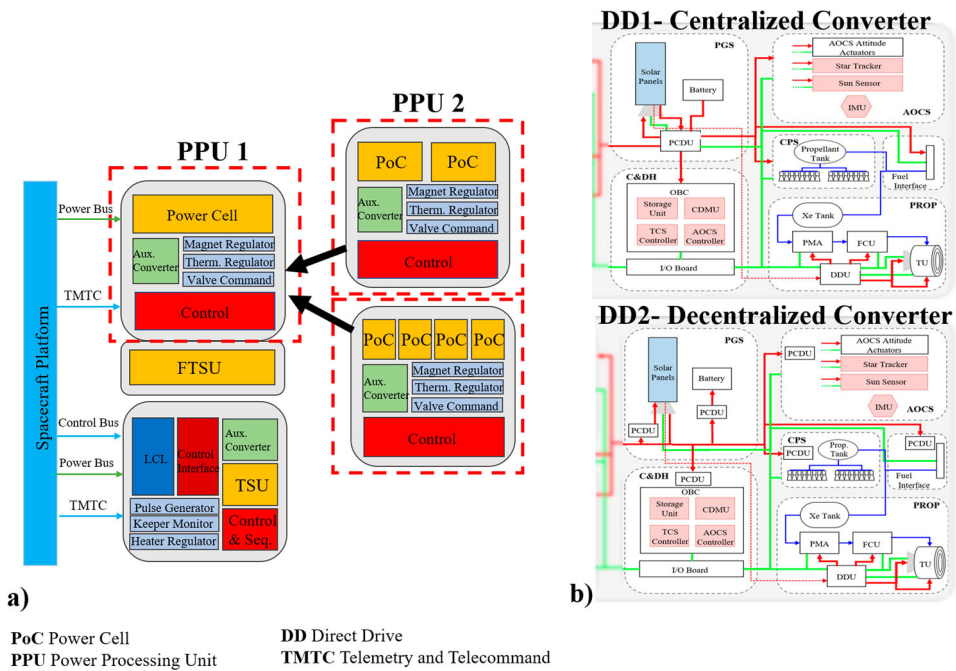

Figure 8. a) PPU architecture alternatives, b) DD architecture alternatives.

first three architectures are based on variations of a conventional DD2 PPU module, as presented in Figure 8a. One of the alternatives is a PPU with one 20 kW power cell (PPU1), another with two 10 kW power cells (PPU2) and a third with five 4 kW power cells (PPU3). The advantage of multiple power cells is the possibility to modularise the PPU to make the design flexible and adaptable to future mission requirements.

The last two alternatives are variations of a DD configuration, where the anode module of the PPU is removed and the TU is directly fed from the power bus connected to the PGS. This configuration has the objective of reducing weight, volume and the number of components (Impresario 2015). The TU is directly connected to an HV power bus connected to a high-voltage SA. As other satellite subsystems might require a low voltage, converters are implemented in the PGS to adapt to the power requirements of the different satellite subsystems. One of the DD alternatives, presented in Figure 8b, has a centralised voltage converter (DD1). The other alternative (DD2) has a distributed converter arrangement, where different converters are assigned to different components.

A centralised converter reduces the number of components and the weight and volume of the equipment that protects the converter from radiation degradation; however, it concentrates thermal control efforts to a single hot spot.

The distributed converter arrangement implements a larger number of smaller converters, facilitating modularity, redundancy and design adaptability. However, these smaller converters can increase volume and weight.

Direct coupling between the PGS and the TU implies the implementation of a high-voltage power bus, which leads to the implementation of a high-voltage battery and solar arrays (Hoskins et al. 2003).

One of the concerns that industrial practitioners raised about the DD configuration is that the new interface presumably requires a new coupling test between the TU and the PGS. This new coupling test is modelled as presented in equations 5 and 6.

Duration:

$$DCoupling_{PGS-TU} = (40, 60, 120) \frac{V_{SA}}{100} \tag{5}$$

$$Cost : CCoupling_{PGS-TU} = N_{eg} \times 22 \times DCoupling_{PGS-TU} \tag{6}$$

By implementing the T&Q model adapted to the 20 kW HT and equations 5 and 6, the cost and duration of T&Q phases for the five architecture alternatives can be analysed.

Figure 9a (table) and 9b (graph) present the results of the T&Q activities for the five different architectures (PPU1, PPU2, PPU3, DD1 and DD2) performed under two different schedules (Figure 9c–d).

Firstly, a schedule with single test models (only one EM, EQM and PFM for each module) was implemented, denoted with the index “A”, as in PPUA or DDA (Figure 9c). This schedule alternative eliminates the possibility of parallel activities inside the modules.

Secondly, a schedule with as many test models as necessary for performing activities on the different modules in parallel was considered, denoted with the index “B”, as in PPUB or DDB (Figure 9d).

The three PPUA alternatives (PPU1A, PPU2A and PPU3A) have the same total T&Q duration (1,340 days). This result suggests that the tests performed at a component level in the

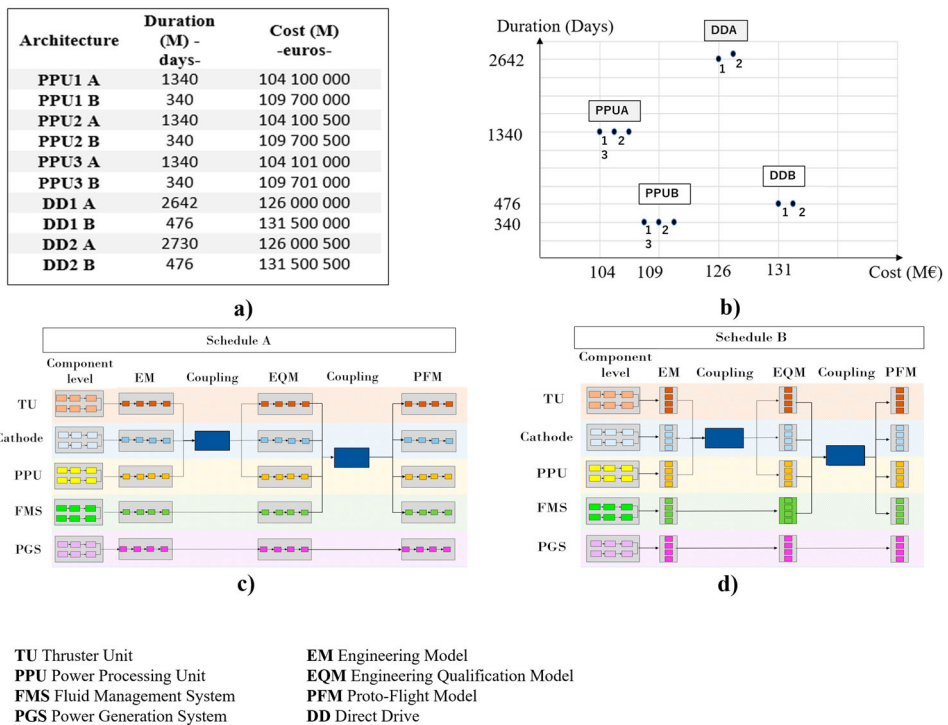

**Figure 9.** Duration vs. cost distribution of T&Q activities for 10 architecture alternatives (a, b) under two different schedules (c, d).

PPU are not part of the critical path of schedule A. Therefore, an increase in the number of PPU components did not increase the total duration of the T&Q activities; however, their cost slightly increased. The same can be observed with PPUB alternatives. From Figure 9a, the schedule B reduced the total duration of the activities to 340 days, increasing their costs by approximately 5%.

The DDA alternatives have a total duration of 2,642 days (DD1) and 2,730 days (DD2) with costs that are approximately 20% higher than the conventional PPU architecture. This result suggests that the converters are part of the critical path of schedule A.

After implementing schedule B, costs increased by approximately 4%. DDB architectures have T&Q activities with a total duration of 476 days, implying that the T&Q activities for the converters are not in the critical path of schedule B.

These results suggest that architectural changes can have a different, sometimes unintuitive, impact on the T&Q activities, depending on the part of the system unit they are implemented in.

Moreover, the duration of the T&Q activities for conventional PPU configurations for 20 kW HT and 5 kW HT is the same, as the identified drivers for activity duration are independent of the thruster power. However, the T&Q of a 20 kW HT is estimated to be 60% more expensive than the T&Q of a 5 kW TH. These results resonated well with estimations made by company experts.

DD architectures enable a reduction in weight and volume (Hoskins et al. 2003), corresponding to a reduction in the number of components (the anode supply is removed from the PPU) and component interfaces (the two interfaces, PGS-anode supply and anode supply-anode, are replaced with the interface PGS-TU), as presented in Figure 10.

In Figure 10, the cost and duration of T&Q activities for PP1A and DD1A are compared. The activity DSMs have been colour-coded from green (low cost/duration) to red (high cost/duration).

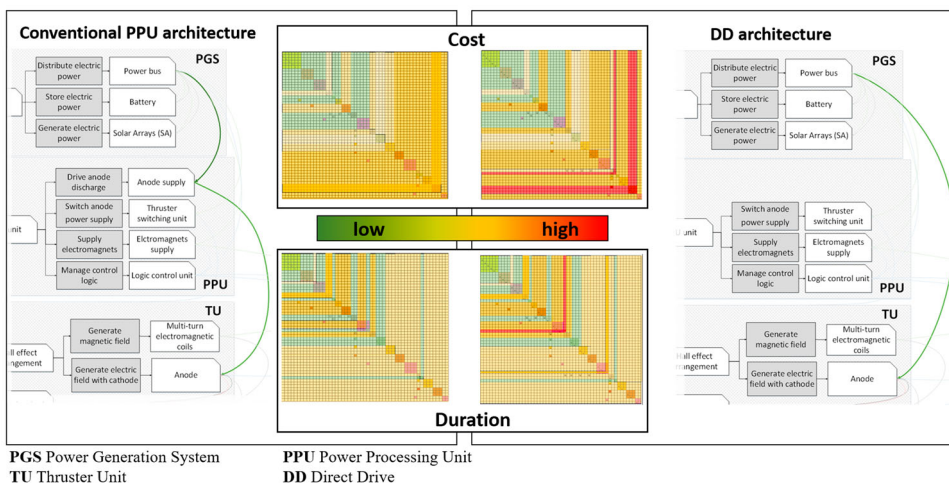

**Figure 10.** Comparison of PPU and DD architectures. In the middle, DSMs have been colour-coded to compare activity cost and duration for both architecture alternatives.

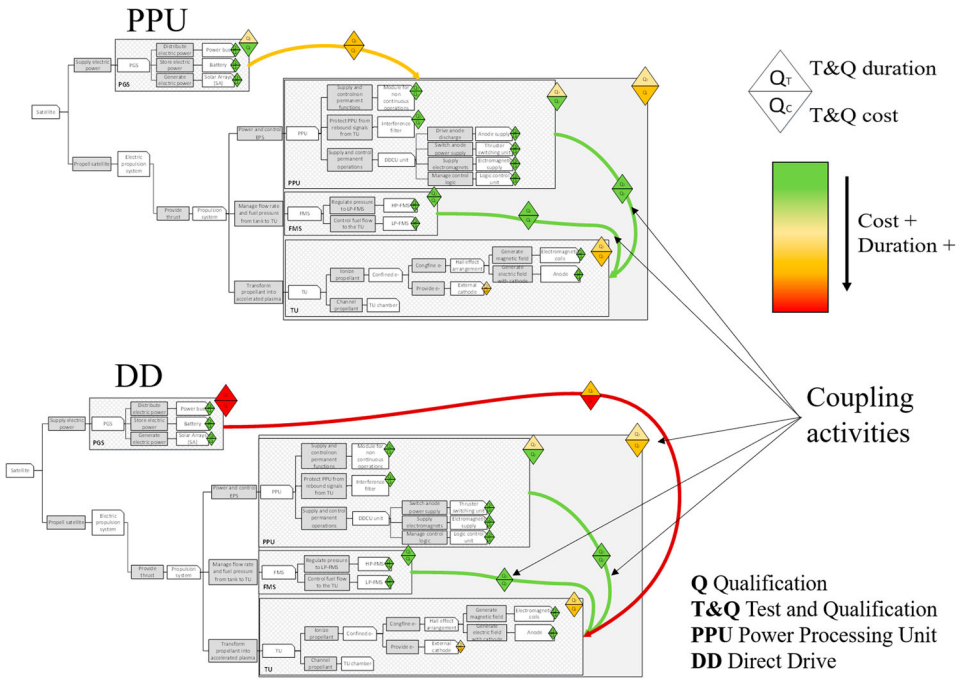

**Figure 11.** Representation of T&Q duration and cost in a function model scheme.

However, this component reduction negatively impacts the duration and cost of the T&Q performed and visualised in the colour-coded DSMs in Figure 10 as the red rows and columns. This increase is mostly related to the high-voltage components and the coupling tests between the TU and the SA.

In Figure 11, the colour-coded DSMs are represented in a function model scheme to visualise the T&Q duration and cost of different architectural components. In this figure, the activities in the DSM are connected to their corresponding design solutions (white boxes) in the function model, as diamonds. These diamonds indicate activity duration (top) and cost (bottom) and are colour-coded from green to red, as done in Figure 10.

The model implementation and visualisation of its results in Figure 11 suggest that to render the DD architectures conveniently, test activities related to the SA and coupling between the TU and the SA must be redesigned. Moreover, design efforts should focus on redesigning the components or interfaces that undergo long and expensive tests. One solution can be the implementation of dedicated SAs (physically separated SAs with different voltages), reducing the number of converters and the consequences of the interaction between the SA and the TU plume (Impresario 2015).

### 6. Discussion

The proposed DfQ method supports the development of products with affordable T&Q phases. The method is based on modelling T&Q activities by linking product architecture and test schedule through the identification and quantification of drivers and driver rates, as proposed by Ben-Arieh and Qian (2003). In this article, their work is taken one step further

to support architectural design trade-off decisions to reduce the duration and cost of the PDP while still developing a reliable product.

The DfQ method is not intended to frame T&Q requirements as the only requirements to be addressed during architectural design. The method and proposed models are tools for facilitating the introduction of T&Q requirements in early multidisciplinary design trade-offs.

Identifying and quantifying drivers and driver rates allow the identification of test-intensive components, modules and subsystems. Table 1 evidences that electrical components undergo longer testing and incur more costs than mechanical TU components. Moreover, it is possible to identify the longest and more expensive tests (Figures 10 and 11).

In the case study, significant differences were observed between the duration and cost of T&Q activities for architectures with conventional PPU and architectures with DD. The results suggest that conventional PPU architectures can be modularised and designed to be adaptable to different requirements of an EPS product family without incurring higher costs and longer T&Q phases. In the case of the DD configuration, however, adaptability and modularisation are penalised with longer and more expensive T&Q phases.

In this context, by implementing the DfQ method, the expensive and long T&Q activities for a DD architecture can be identified and targeted for redesign. In the same way, the DD components and interfaces that undergo long and expensive tests can be also identified and redesigned.

The DD configuration changes not only the PPU architecture at a component level but also the subsystems interfaces. These modifications at the subsystem interface level lead to additional test activities and modifications at the component level in the PGS. The impact that design changes have on T&Q duration and cost depends on the system level affected. Therefore, the importance of computer-based schedule calculations is based on the DSMs.

In this context, the presented method can facilitate communication and cooperation between the development and testing departments, where colour-coded activity DSMs from Figure 10 and the function model from Figure 11 can function as boundary objects. The method, therefore, enables the concurrent design of product architecture, T&Q schedule and T&Q activities as well. This fact is particularly interesting for the implementation of new technologies or in any other design situation where the qualification phases might not be well defined.

The data gathering and model development for this method was performed for the equivalent of 60 working days (8hs/day; Figure 1), in the context of a product with qualification phases lasting around 1,400 days (4%). However, these activities included the development of the method, where the information and models are meant to be updated with each development project of similar nature in a design organisation.

The time to perform the study is likely to depend on the type of product to be designed, the components and the design context, which is why the effort needed to perform it cannot be generalised.

To increase the capabilities of the method and the accuracy of its results, three areas of improvements have been identified:

- In this study, the activity model and, consequently, the DSM have been simplified assuming that activity durations are independent of each other and that activity duration

accounts for rework efforts. However, the DSM representation was preferred, as it enables future calculations about the interdependencies and overlapping of activities, the design iteration and the schedule optimisation, as proposed by Maheswari and Varghese (2005) or Huang and Chen (2006). These capabilities can improve T&Q estimations and contribute to cost and duration optimisation.

- Companies designing products for space applications strive for extreme reductions in cost and time to market while maintaining high reliability. Relaxing qualification requirements of individual units is an increasingly popular alternative among, for instance, mega satellite constellation developers to reduce costs and time to market (Öhrwall Rönnbäck and Isaksson 2018). In this case, reliability is achieved at the mega-constellation level instead of the unit level (Sánchez, Soares, and Wolahan 2017). Regardless of the preferred approach to attain reliability, T&Q models can be combined with risk analysis strategies to assess the risks (product and financial) of not performing (or partially performing) certain T&Q activities. In this case, the risk would be considered a T&Q driver. An example of risk assessment in the context of VVT activities can be found in the work of Engel and Barad (2003). Efforts to include risk assessments in the proposed methodology are currently ongoing. These efforts propose the implementation of fuzzy logic techniques for modelling technology uncertainties and risks related to T&Q in space products.
- Cost and duration were modelled with a triangular PDF as a simplification of beta PDFs. This modelling choice assumes that the shape of PDFs is known and able to be represented as beta functions (Liberatore 2002). To improve the representation of duration and cost probability, a fuzzy logic modelling strategy can be adequate, as previously demonstrated by Liberatore (2002) or Masmoudi and Haït (2012).

The presented model-based DfQ method is meant to be generalised for the integration of new technologies into product architectures. The case study in this article is specific to the EPS design of a satellite thruster. As such, generalised validity will require the method to be repeated on other technologies and other product contexts.

An appropriate method validation must be based on validation strategies for design methods, such as the one proposed by Pedersen et al. (2000). Emphasis should be on evaluating whether the results obtained (products with affordable T&Q phases) are related to the method application and not to other factors. Such a study can compare design outputs from different design teams, some with the DfQ method and some without.

## Conclusion

In this article, a model-based DfQ method for integrating T&Q procedures into the conceptual design and evaluation of product architectures is presented. The novelty of the method lies in linking product architecture alternatives with T&Q activities and schedules through the identification and quantification of T&Q drivers and driver rates. It is demonstrated how the method implemented in the case of a satellite thruster component allows designers to design their components to mitigate the substantial risk of design iterations due to late discovery of qualification issues.

It is proposed that by defining qualification drivers, the defining characteristics of a qualification procedure can be quantitatively modelled and integrated into a design study

where alternative technologies and concepts are investigated. Therefore, the method can be applied to various design situations where the choice of technology has a strong dependence on the qualification procedure. However, further validation of the method's generalisability is required and is left for future research activities in this domain.

The DfQ method was utilised to model T&Q phases for a 5 kW hall thruster. After implementing the T&Q model, qualification procedures were integrated into the conceptual design and evaluation process of a 20 kW thruster.

## Acknowledgements

This study is based on the results from project CHEOPS (Consortium for Hall Effect Orbital Propulsion System), which has received funding from the European Union's Horizon 2020 research and innovation programme under grant agreement No 730135.

## Disclosure statement

No potential conflict of interest was reported by the author(s).

## Funding

This work was supported by European Union's Horizon 2020 research and innovation programme [Grant Number 730135].

## ORCID

Olivia Borgue  <http://orcid.org/0000-0001-8886-2323>

Ola Isaksson  <http://orcid.org/0000-0003-0373-3720>

## References

- Ben-Arieh, D., and L. Qian. 2003. "Activity-based Cost Management for Design and Development Stage." *International Journal of Production Economics* 83 (2): 169–183.
- Borgue, O., M. Panarotto, and O. Isaksson. 2019. "Modular Product Design for Additive Manufacturing of Satellite Components: Maximizing Product Value Using Genetic Algorithms." *Concurrent Engineering* 27 (4): 331–346.
- Browning, T. R., and S. D. Eppinger. 2002. "Modeling Impacts of Process Architecture on Cost and Schedule Risk in Product Development." *IEEE Transactions on Engineering Management* 49 (4): 428–442.
- Claesson, A. 2006. "A Configurable Component Framework Supporting Platform-Based Product Development." PhD thesis, Chalmers University of Technology, Gothenburg, Sweden.
- Dodin, B. 1985. "Bounding the Project Completion Time Distribution in PERT Networks." *Operations Research* 33 (4): 862–881.
- Dordlofva, C., O. Borgue, M. Panarotto, and O. Isaksson. 2019. "Drivers and Guidelines in Design for Qualification Using Additive Manufacturing in Space Applications." In *Proceedings of the Design Society: International Conference on Engineering Design*, edited by S. Wartzack, B. Schleich, and Gon, 729–738. Cambridge: Cambridge University Press.
- ECSS. 2008. "ECSS-Q-ST-70-45C – Mechanical Testing of Metallic Materials." ECSS-European Cooperation for Space Standardization. <https://ecss.nl/standard/ecss-q-st-70-45c-mechanical-testing-of-metallic-materials/>.
- ECSS. 2013. "ECSS-Q-ST-60C Rev.2 – Electrical, Electronic and Electromechanical (EEE) Components." ECSS-European Cooperation for Space Standardization. <https://ecss.nl/standard/ecss-q-st-60c-rev-2-electrical-electronic-and-electromechanical-eee-components-21-october-2013/>.

- ECSS. 2018. "ECSS-E-ST-10-02C Rev.1 – Space Engineering - Varification." ECSS-European Cooperation for Space Standardization. <https://ecss.nl/standard/ecss-e-st-10-02c-rev-1-verification-1-february-2018/>.
- Engel, A., and M. Barad. 2003. "A Methodology for Modeling VVT Risks and Costs." *Systems Engineering* 6 (3): 135–151.
- Hoskins, A., D. Homiak, R. J. Cassady, T. Kerslake, T. Peterson, D. Ferguson, D. Snyder, I. Mikellides, G. Jongeward, and T. Schneider. 2003. "Direct drive Hall thruster system development." 39th AIAA/ASME/SAE/ASEE Joint Propulsion Conference and Exhibit.
- Huang, E., and S. J. Chen. 2006. "Estimation of Project Completion Time and Factors Analysis for Concurrent Engineering Project Management: A Simulation Approach." *Concurrent Engineering* 14 (4): 329–341. doi:10.1177/1063293X06072482.
- Impresario, G. 2015. "Design and simulation of a 5 kW Hall Thruster direct drive experiment." Corso di Laurea Specialistica in Ingegneria Aerospaziale, Tesi di Laurea, Dipartimento di Ingegneria Civile e Industriale, Università di Pisa.
- ISO/IEC/IEEE. 2020. ISO/IEC/IEEE 12207-2:2020(E), Systems and Software Engineering — Software Life Cycle Processes, Part 2: Relation and Mapping Between ISO/ IEC/IEEE 12207:2017 and ISO/IEC 12207:2008, 4–27. Vernier, Geneva: ISO/IEC/IEEE.
- Liberatore, M. J. 2002. "Project Schedule Uncertainty Analysis Using Fuzzy Logic." *Project Management Journal* 33 (4): 15–22.
- Maheswari, J. U., and K. Varghese. 2005. "Project Scheduling Using Dependency Structure Matrix." *International Journal of Project Management* 23 (3): 223–230.
- Masmoudi, M., and A. Häit. 2012. "Fuzzy Uncertainty Modelling for Project Planning; Application to Helicopter Maintenance." *International Journal of Production Research* 50 (13): 3594–3611. ISSN 0020-7543.
- Müller, J. R., M. D. I. Siiskonen, and J. Malmqvist. 2020. "Lessons Learned from the Application of Enhanced Function-Means Modelling." *Proceedings of the Design Society: DESIGN Conference 1*: 1325–1334doi:10.1017/dsd.2020.87.
- Öhrwall Rönnbäck, A. B., and O. Isaksson. 2018. "Product Development Challenges for Space Sub-System Manufacturers." *Proceedings of the 15th International Design Conference 1*: 1937–1944. doi:10.21278/idc.2018.0534.
- Pedersen, K., J. Emblemsvåg, R. Bailey, J. Allen, and F. Mistree. 2000. "The 'Validation Square'-Validating Design Methods." ASME Design Theory and Methodology Conference, New York.
- Shabi, J., Y. Reich, and R. Diamant. 2017. "Planning the Verification, Validation, and Testing Process: A Case Study Demonstrating a Decision Support Model." *Journal of Engineering Design* 28 (3): 171–204.
- Shank, J. K. 1989. "Strategic Cost Management: New Wine or Just new Bottles?" *Journal of Management Accounting Research* 1: 47–65.
- Sánchez, A. H., T. Soares, and A. Wolahan. 2017. "Reliability Aspects of Mega-Constellation Satellites and their Impact on the Space Debris Environment." Annual Reliability and Maintainability Symposium (RAMS), Orlando, FL. IEEE.
- Tahera, K., and C. Earl. 2018. "Testing and PLM: Connecting Process and Product Models in Product Development." In *Product Lifecycle Management-Terminology and Applications*, edited by R. Udroui and P. Bere, 73–92. London: IntechOpen.
- Tahera, K., D. C. Wynn, C. Earl, and C. M. Eckert. 2019. "Testing in the Incremental Design and Development of Complex Products." *Research in Engineering Design* 30 (2): 291–316.
- Tatikonda, M. V., and S. Rosenthal. 2000. "Technology Novelty, Project Complexity, and Product Development Project Execution Success: a Deeper Look at Task Uncertainty in Product Innovation." *IEEE Transactions on Engineering Management* 47 (1): 74–87.
- Ulrich, K., and S. Eppinger. 2015. *Product Design and Development*. New York: McGraw-Hill Higher Education.
- Wang, W., M. H. Azarian, and M. Pecht. 2008. "Qualification for Product Development." International Conference on Electronic Packaging Technology & High Density Packaging, Shanghai, China. IEEE.

- Wilson, J. M. 2003. "Gantt Charts: A Centenary Appreciation." *European Journal of Operational Research* 149 (2): 430–437.
- Worldsalaries. 2019. "Engineer Salaries - International Comparison." <http://www.worldsalaries.org/engineer.shtml>.
- Wu, C. L. 2016. *Airline Operations and Delay Management: Insights from Airline Economics, Networks and Strategic Schedule Planning*. New York: Routledge.
- Wyatt, D. F., C. M. Eckert, and P. J. Clarkson. 2009. Design of Product Architectures in Incrementally Developed Complex Products." In *Proceedings of ICED 09, the 17th International Conference on Engineering Design*, Palo Alto, CA, USA, edited by M. Norell Bergendahl, M. Grimheden, L. Leifer, P. Skogstad, and U. Lindemann, 167–178.