

CHALMERS



Applications of Dynamic Modeling in Crushing Plants

MARCUS JOHANSSON

Department of Industrial and Materials Science
CHALMERS UNIVERSITY OF TECHNOLOGY
Gothenburg, Sweden 2021

THESIS FOR THE DEGREE OF DOCTOR OF PHILOSOPHY

Applications of Dynamic Modeling in Crushing Plants

Marcus Johansson



Department of Industrial and Materials Science
CHALMERS UNIVERSITY OF TECHNOLOGY
Gothenburg, Sweden 2021

Applications of Dynamic Modeling in Crushing Plants

MARCUS JOHANSSON

ISBN 978-91-7905-490-8

© MARCUS JOHANSSON, 2021.

Doktorsavhandlingar vid Chalmers tekniska högskola

Ny serie nr 4957

ISSN 0346-718X

Department of Industrial and Materials Science

Chalmers University of Technology

SE-412 96 Gothenburg, Sweden

Telephone + 46 (0) 31 – 772 1000

Cover: Figure 1.2, overview of a crushing plant.

Typeset by the author using L^AT_EX.

Printed by Chalmers Reproservice

Gothenburg, Sweden 2021

"Destroying solids by cracking them is a fascinating subject which may be considered good or bad depending on one's point of view." - K. Schönert

Abstract

Modeling is a tool to describe phenomena in a simplified way, and the models can then be used to simulate these phenomena. Models of equipment used in the mining and aggregate industries can be used for process simulations of the processes in those industries to improve the operations. To study processes and the operation of processes, time dynamic models are a great tool. This thesis focuses on applications of time dynamic modeling in crushing plants. The time dynamic models predict the output of the equipment as a function of time. The work presented within this thesis focuses on three areas; Unit modeling, process modeling, and control modeling.

Unit modeling refers to developing models of single processing units, which could be a comminution unit, classification unit, or materials handling unit. The new models presented in this thesis are for jaw crushers, high pressure grinding rolls (HPGR), and storage units (e.g., bin, silo, or stockpile). The developed models are based on the fundamental insight of the physics that happens within the unit. The validity of the models is aimed to be broad and cover many operating points and uses. The models are intended for high fidelity process simulation applications.

Process modeling refers to the modeling of many interconnected units, and the modeling presented in this thesis has been done with both high-fidelity unit models and with simplified models. Both high fidelity and simple simulations are demonstrated within the thesis. The simpler models are used to try new concepts of plant design or control and study plant robustness or ability to handle variations. Meanwhile, the high-fidelity models can be used to study topics such as particle size distribution, debottlenecking and specific control issues.

Control modeling refers to developing controller models to control plants like those modeled within the process modeling section. Optimal control, such as model predictive control (MPC), relies on models to steer processes optimally relative to some objective. The models within those controllers have been discussed in this thesis. Additionally, being able to move between the various fidelity domains of models is beneficial for this application.

In this thesis, multiple new models and methods are presented, along with how they can be applied within the minerals processing and aggregate industry, ultimately improving the efficiency and performance of the industries.

Keywords: Dynamic modeling, HPGR, Jaw crusher, Minerals processing, Process control, Comminution, Material storage, Robustness, Plant design, Calibration

Acknowledgments

I want to acknowledge my examiner and supervisors for trusting me to complete this research. The support from current and previous colleagues at Chalmers is also acknowledged. A special thanks to Dr. Johannes Quist for getting me inspired into research during those earlier years and to Associate Prof. Magnus Bengtsson for the continued guidance and support.

A major part of this journey has been possible only due to support from the industry worldwide. Anglo American and all partners through the Global Comminution Collaborative are especially acknowledged, both in terms of interest and financial support. This research has also received support from Ellen, Walter, and Lennart Hasselman's foundation for scientific research, their support is acknowledged. Finally, thanks to friends and family for continually supporting me.

Marcus Johansson

Gothenburg, April 2021

Publications

Appended papers:

- Paper A.** Marcus Johansson, Magnus Bengtsson, Magnus Evertsson, Erik Hulthén *A fundamental model of an industrial-scale jaw crusher*, Published in Minerals Engineering, vol 105(69-78), 2017.
- Paper B.** Marcus Johansson, Magnus Evertsson *A time dynamic model of a high pressure grinding rolls crusher*, Published in Minerals Engineering, vol 132 (27-38), 2019.
- Paper C.** Marcus Johansson, Magnus Evertsson *Applying linear model predictive control to crushing circuit simulations*, Published in proceedings of IMPC 2018 - 29th International Mineral Processing Congress, p. 3423-3432, Moscow, September 2018.
- Paper D.** Marcus Johansson, Magnus Evertsson, Erik Hulthén *Analysis of dynamic process characteristics in crushing plants from a robustness point of view*, Published in proceedings for the 11th International Comminution Symposium, Cape Town, South Africa, April 2018.
- Paper E.** Marcus Johansson, Magnus Evertsson *Time dynamic modeling and control of an HPGR circuit*, Published in proceedings of the Conference in Minerals Engineering, Luleå, February 2018.
- Paper F.** Marcus Johansson *A time dynamic model of material storage units*, Submitted for publication in Applied Mathematical Modelling, November 2020.
- Paper G.** Marcus Johansson *Robust crushing stage design*, Submitted for publication in Minerals Engineering, Feb 2021
- Paper H.** Marcus Johansson *A method for calibration of dynamic simulation models*, Presented at the 12th International Comminution Symposium, Online, April 2021.

Work distribution:

Paper A: Johansson and Bengtsson initiated the idea, Johansson developed the model with support from Bengtsson. Johansson wrote the paper with Bengtsson, Evertsson and Hulthén as reviewers.

Paper B & C: Johansson and Evertsson initiated the idea. Johansson implemented the code. Johansson wrote the papers with Evertsson as a reviewer.

Paper D: Johansson and Evertsson initiated the idea. Johansson implemented the code. Johansson wrote the paper with Evertsson and Hulthén as reviewers.

Paper E: Johansson wrote the paper with Evertsson as a reviewer.

Other relevant publications:

Marcus Johansson, Magnus Evertsson, Gauti Asbjörnsson *Improvement Opportunities using Time Dynamic Simulations*, Published in proceedings of the 15th European Symposium on Comminution and Classification, 2017.

Marcus Johansson, Magnus Evertsson, Erik Hulthén *A Novel Approach to Cone Crusher Feeding Using High frequency Power Draw Measurements*, Published in proceedings of the 15th European Symposium on Comminution and Classification, 2017.

Marcus Johansson, Johannes Quist, Magnus Evertsson, Erik Hulthén *Cone crusher performance evaluation using DEM simulations and laboratory experiments for model validation*, Published in Minerals Engineering, p. 93-101, 2016.

Marcus Johansson, Johannes Quist, Magnus Evertsson *Bonded Particle Model Calibration Using Design of Experiments and Multi-Objective Optimization*, Published in proceedings of the MEI 10th International Comminution Symposium (Comminution '16), 2017.

Marcus Johansson, Johannes Quist, Magnus Evertsson, Erik Hulthén *Investigation of High Speed Cone Crushing Using Laboratory Scale Experiments and DEM*, Published in proceedings of the 14th European Symposium on Comminution and Classification (ESCC 2015), p. 193-199, 2015.

Contents

Abstract	v
Acknowledgments	vii
Publications	ix
I Thesis	1
1 Introduction	3
1.1 Systemic view	3
1.2 Physical plants	4
1.3 Modeling	6
1.4 Industrial process control	7
2 Background	9
2.1 Drivers	9
2.2 Models, tuning and validation	10
2.3 Research questions	10
3 Scientific approach	13
4 Theory	15
4.1 Modeling of comminution and classification systems	15
4.2 Crushing machines	16
4.2.1 Jaw crushers	16
4.2.2 HPGR	17
4.3 Storage units	19

4.4	Model based control algorithms	20
4.5	Stability and robustness of plants	22
5	Method	25
5.1	Physical modeling	25
5.1.1	Comminution modeling	26
5.1.2	Modeling of storage units	29
5.2	Process modeling	31
5.2.1	Robustness and circuit analysis	31
5.2.2	Circuit modeling and calibration	33
5.3	Control modeling	35
6	Results	41
6.1	Equipment modeling	41
6.1.1	Comminution equipment	41
6.1.2	Storage unit modeling	46
6.2	Process control	49
6.3	Circuit modeling	51
6.3.1	Robustness simulations	51
6.3.2	Circuit simulations and calibrations	58
7	Discussion	61
7.1	Answers to the research questions	63
7.2	Future work	67
	Bibliography	69
II	Appended papers	75
A	A fundamental model of an industrial scale jaw crusher	77
B	A time dynamic model of a high pressure grinding rolls crusher	89
C	Applying linear model predictive control to crushing circuit simulations	103

D	Analysis of dynamic process characteristics in crushing plants from a robustness point of view	117
E	Time dynamic modeling and control of an HPGR circuit	131
F	A time dynamic model of material storage units	145
G	Robust crushing stage design	157
H	A Method for calibration of dynamic simulation models	169

Part I

Thesis

Chapter 1

Introduction

This chapter will give a brief introduction to this thesis's topic from a few different points of view.

1.1 Systemic view

The technologically advanced world in which we live relies on the metals and minerals from the mining industry to function properly. Products from aggregate plants are used in nearly all construction and infrastructure projects. Metals are crucial to our modern society, and without them, society would not be functioning as we know it today. Metals are used in everything from infrastructure to our cell phones, and a life without them would be very different from today. The two ways to acquire metals are either by mining new ore bodies or by recycling old products. The mining industry is a large industry, responsible for \$683 billion USD [43] in revenue for the year of 2019, and consuming enormous amounts of resources, such as energy, water, chemicals, and spare parts. The freshly mined metals are sold either at a spot price or as a contract on a global market. The supply and demand for these metals vary and are highly affected by politics, economic cycles, and many other factors. In mining new resources, there is a chain of events that occur before the commodity reaches the market. An illustration of the value chain is pictured in Figure 1.1. When prospectors have located a resource and determined if the resource is economically feasible to mine, mining rights have to be obtained. From there on, a mine can be established and a concentrator built. Thereafter the actual processing of ore can start, and it is mainly at this point where this thesis can be applied. As the industry is located in the global system and affected in many ways, it is important to keep this context in mind when analyzing trends, decisions, and responses of different stakeholders.

This research focuses on the gray block in Figure 1.1 in general and specifically comminution and classification, which are the two stages enclosed by the dashed line. All of the other stages in the value chain are equally important for the industry.

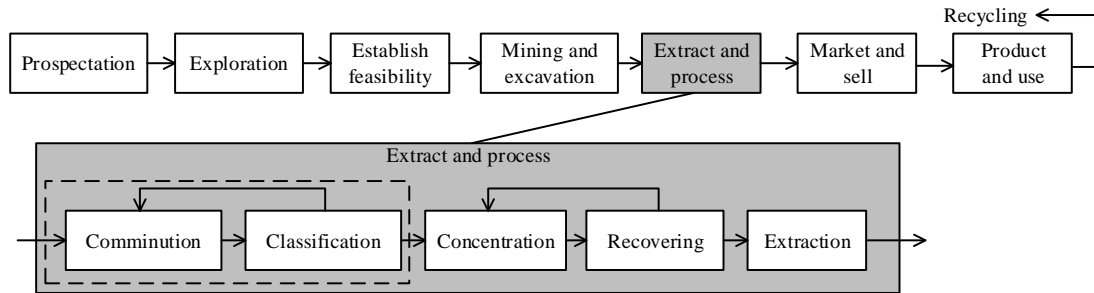

Figure 1.1: A generalized value chain for the mining and metals industry, modified from Rajagopalan [25]. This thesis focuses on the dashed box on the second row, comminution, and classification.

However, it is not the focus of this thesis. Comminution and classification are also important processes in the aggregate and cement industries, which use the same type of processes and equipment as the mining industry. However, the specification of the final product is different.

1.2 Physical plants

Rock is excavated from the ore body by drilling followed by blasting, then loaded and hauled to be primarily crushed. The blasted rock can come in large pieces that cannot be transported on a belt conveyor. After primary crushing, the rock is now of adequate size (0-300 mm) to be transported on a belt conveyor. Thereafter the rock is again crushed in a series of crushing stages using a combination of jaw crushers, cone crushers, HPGRs, or in some cases AG- or SAG-mills¹. How many, what type and configuration vary from plant to plant, and the applications. After crushing, the finely crushed rock is, in most cases, milled to the final size and a powder by, for example, using tumbling mills. Milling is most often, except in the cement industry, a wet process, where water is added to the product stream, creating a slurry. This slurry is then transferred to a separation process where the gangue rock and the valuable minerals are separated. In general terms, this is called concentration. There are other methods for separation, such as leaching, which dissolves the minerals into a solution that can be chemically treated to extract the dissolved metal. A more detailed description of how minerals processing plants are built up is presented by Wills [57]. The concentrators or processing plants are massive installations in terms of their physical and economic footprint. Part of such an installation can be seen in Figure 1.2. The significant investment made when deciding to build a plant requires it to be used for many years into the future to make the investment economically viable. A plant's goal is to process as much as possible or the desired amount to the

¹S/AG, semi/autogenous grinding, SAG mills use both steel balls and rock as grinding media and AG mills use only rock as grinding media



Figure 1.2: A minerals processing plant and an overview of the conveying system between crushers, screens and storage units.

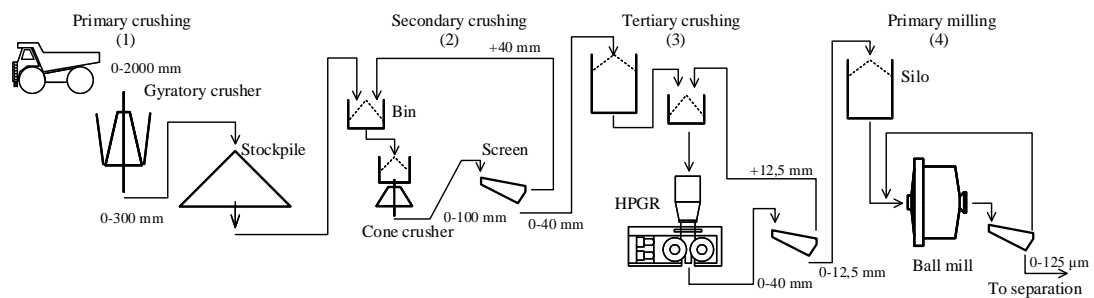

Figure 1.3: A simplified and ideal flowsheet with four stages of comminution and three classification stages.

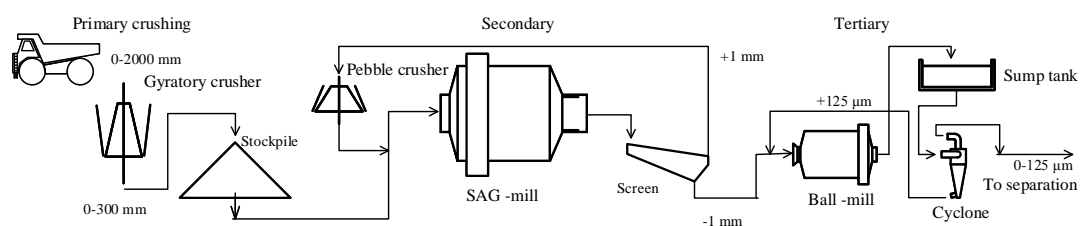

Figure 1.4: A simplified and ideal flowsheet for a SAG-mill circuit with regrinding (ball mill) and pebbles crushing.

highest quality possible. In mining, every hour that a plant is not operating is a lost production hour, and there is no way of getting lost production back.

This thesis concerns only some parts of the processing chain, and it is vital to see the bigger picture in terms of the processing plant to understand the context of the thesis. To exemplify, two top-level flowsheets are shown in Figure 1.3 and 1.4 to illustrate two different processes. In Figure 1.3, the process contains four

stages (1-4) of comminution with classification. This could be a possible setup for a minerals processing concentrator. The product from the pictured flowsheet continues to a separation process and possible further regrinding if needed. In Figure 1.4 a flowsheet for a SAG circuit is drawn. This is an alternative to the more crusher-focused flowsheet in Figure 1.3. Pebbles crushing is sometimes a required addition to traditional SAG circuits in the way it is illustrated in Figure 1.4. Especially since the general trend is that ores are getting harder and it, therefore, becomes nearly impossible to grind down the critically sized particles (pebbles).

1.3 Modeling

A model is a way of describing a phenomenon in a simplified way. In this research, mathematics is used as a modeling tool to describe reality. A model is never perfect as it comes with assumptions as part of the simplified description of the real phenomenon. The modeling exercise can go on forever, trying to develop a refined model that is perfect. Traditionally, modeling and simulation of comminution systems have been carried out in steady-state, resulting in a steady-state response from the system. This includes simulations software such as, JKsimMet², AggFlow³ and ModSim⁴. The mentioned three are some of the earlier available software, and today there are many more available alternatives. The development of simulation platforms for comminution circuits started before computer technology had grown to be as powerful as it is today. Computational resources, complexity, and knowledge were all reasons for using steady-state simulations rather than dynamic simulations. Whiten [56] presented simulations of a closed crushing circuit, and Ford and King [18, 19] presented solutions to simulate entire plants, from crushing to separation. The techniques presented in the papers by Ford, Whiten, and others have contributed to developing the above mentioned steady-state simulation software.

This thesis focuses on time dynamic modeling, which gives time-dependent responses and does not suppress process variations. The above mentioned simulation software will only give one answer for each stream of a flowsheet. This has implications such that natural and process variations will not be visible in the answers and that problems related to control and some operational aspects can not be studied or observed. By utilizing dynamic models, a new set of problems can be studied, which is impossible with steady-state simulators. Additionally, the ability of the dynamic models to be virtual copies of real assets opens up a new dimension for how operational efficiency can be improved.

Regardless of making models for steady-state simulations or time dynamic simulations, a model structure is needed. A generic block model layout is shown in Figure 1.5, including notation for, feed (F), model parameters (p), model inputs (u), internal variables (x), product (P) and model outputs (y).

²<https://jktech.com.au/jksimmet>

³<https://www.aggflow.com/aggflow-design>

⁴<http://www.mineraltech.com/MODSIM/>

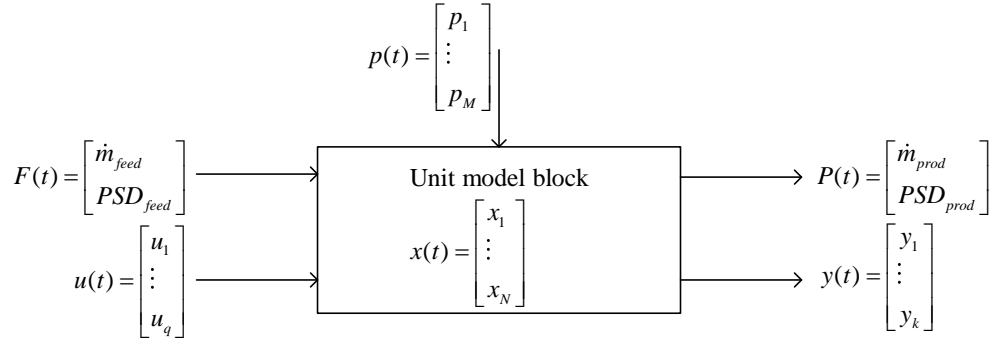

Figure 1.5: An example of a unit model with the different variables and parameters associated with the model.

For research purposes, it is practical to develop models on a stand-alone platform, where there is full access to the source code of the models and the setup. The modeling work within this thesis builds mainly upon the work of Evertsson, Asbjörnsson, and Bengtsson [15, 1, 9]. The environment used for model development and simulation is MATLAB and Simulink, mainly for historical and practical reasons. However, any mathematically friendly coding environment can be used to simulate and develop time dynamic models. The goal of the modeling is to make as accurate models as possible. The models are aimed to be used in time dynamic simulations, implying that they are stepped one time step at the time and with changing inputs. This is different from a steady-state simulation, where the simulation model is iterated until the mass balance is found. Steady-state is an equilibrium state that can be found with dynamic simulations as well. However, with all the variations present in real-world plants, the actual existence of steady-state for a longer time period can only be achieved under special conditions and is therefore unlikely.

This thesis has a focus on process models, mostly time dynamic, and the critical requirements on those models are to:

- Run faster than real-time when simulated.
- Respond to changes in the process, both machine settings, and operating conditions.
- Be predictive and possible to operate in a specified range of conditions.

The list above contains enablers to use the simulation models for; plant optimization, controller tuning, and green and brownfield improvement studies.

1.4 Industrial process control

Industrial processing circuits consisting of large-scale equipment, both valuable and powerful, should have proper control installed for many reasons. The different

systems involved in the control of an industrial plant are pictured hierarchically in the triangle in Figure 1.6. The triangle is an interpretation of the structure introduced by Tatjewski [55]. The lowest functions protect the integrity of the plant, its employees, and the equipment. These are typically in the form of interlocks and protective functions that inhibit things from going wrong and people from getting injured. The next level above is the Single Input Single Output (SISO) layer of control loops, which are present at most sites within minerals processing. SISO-loops are, for example, control of a level or a flow in the process. On top of SISO-loops, there could be Multi Input Multi Output (MIMO) controllers. These controllers handle multiple inputs to control multiple outputs towards an objective under a given set of constraints. A MIMO controller could be in the form of a linear quadratic regulator (LQR) or a model predictive controller (MPC). These controllers are optimizing the different settings to operate the process at the most beneficial operating point. The most beneficial operating point is described by the objective of the controller. On the very top level, there is management, who decides, for example, desired production volumes and operating hours. Decisions regarding production by management, for example, plant managers, CEO's and principals in the mining industry, are also influenced by factors such as political stability, environmental goals, metal prices, resource availability, and more.

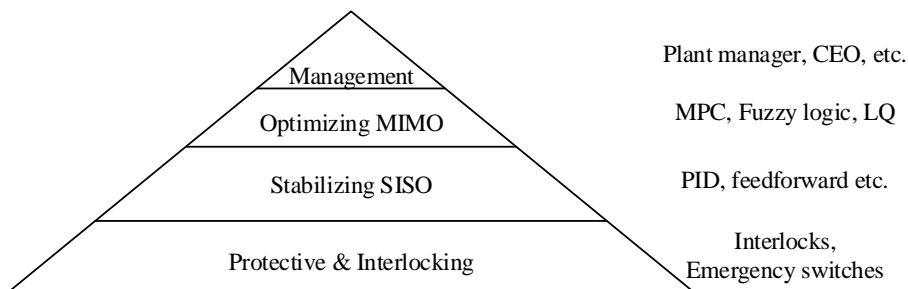

Figure 1.6: Hierarchical construction of the different means of control used on a plant.

Traditionally, crushing plants especially did not have much automatic control before the 1980's. Protective systems were installed, but in terms of automatic control, most plants were operated manually from control rooms to a large extent. This was very labor-intensive, and humans tend to get tired of tasks, while computers do not. Mining is more and more being done in remote parts of the world and making it, to some extent, hard to find the labor to work on site. This has created an increased need for control and automation and the ability to do some tasks remotely. As automation increases, more opportunities arise to use more accurate and advanced process control to improve operations further.

Chapter 2

Background

In this chapter, the motivation behind this research will be explained, both in terms of underlying drivers and the research questions.

2.1 Drivers

Minerals processing is a process industry and, profitability in the minerals processing industry is about maximizing production volumes and maintaining the highest possible recovery percentage of the mined minerals. In the aggregate industry, profitability is about producing a high-quality product at the lowest possible price. The task is getting more challenging as the grades of the readily available ore-bodies are decreasing, and additionally, as mines are extended to further depths below the earth's crust, the ore is getting more difficult to process. The enablers that allow a plant to increase production or produce a better quality product could be the difference between being profitable or not. The mining industry is a global industry found on all continents worldwide except in Antarctica¹. A successful business involves understanding and dealing with an ever-changing operational environment. Industrial actors are affected in three main ways:

- Environmental
- Legal and Social
- Economical

For all companies involved in mining activity, it is essential to ensure that all the above aspects are fulfilled, especially for the legal and environmental aspects. In recent years, additional pressure has been put on companies buying minerals for their production to buy from socially and sustainably acceptable production sites. This has been especially important in battery and electronics productions, where

¹Antarctica is protected from exploitation under the Antarctic Treaty

many metals and, in particular with cobalt, which have been mined in war zones and/or under poor conditions and even with child labor.

The third aspect in the list, the economical, is directly coupled to this thesis's content. Efficiency² and performance³ will determine how profitable a site is. These two measures are directly linked to the operation and how well the operation is executed. Performance is the combined result of quality and quantity of produced products. In minerals processing, it is about maximizing the amount of product containing the minerals that can be separated from the gangue ore. Accurate control and understanding of the processes involved in this chain of events will inevitably increase the chances of getting better positioned on the cost curve. Profitable operation is needed to survive, and one way of doing that is making sure that the operation of the process is as efficient as possible. This research targets the questions about how to be as efficient as possible and presents methods and tools that can be used to analyze and study operations to achieve better efficiency.

2.2 Models, tuning and validation

Multiple of the outcomes from this thesis is in the form of models. Models are representations of reality, and in this context, comminution machines, classification machines, and materials handling units. To trust a model, it needs to be verified against measurements of the real process modeled. In the process of arriving at a model that can be trusted, the steps, tuning, calibration, verification, and validation are essential. Tuning and calibration involve adjusting the model to fit the observations or measurements. Verification and validation are steps to evaluate how the model performs. The difference between calibration or tuning and validation is that validation data have not been used when calibrating or tuning the model. Validation data should be new or unseen data to the model. If possible, it is important to have enough data and separate the calibration and validation datasets. All models have a range of validity, and to confirm this, verification and validation are needed [32]. Verification of how a model behaves can be done by inspection if the modeled unit is well understood. However, validation is done by comparing the model to actual measurements. Validation is considered stronger as evidence than verification. Strictly a model should only be used within its range of validity.

2.3 Research questions

The following research questions have been formulated. They are divided into three main categories; equipment and process modeling (R.Q.1-R.Q.4), process design and robustness (R.Q.5-R.Q.6), and process control (R.Q.7-R.Q.8). The text underneath the question is to explain the question further and to clarify what the target is.

²A measure of the cost and/or resources required to produce one unit.

³A measure of the speed at which a specific product can be produced.

R.Q. 1: How can high fidelity fundamental models of minerals processing equipment be developed in order to handle machinery of force-conditioned type?

A fundamental model is based on physical laws and constitutive relations and should capture a wide operating range of the machine being modeled. A model based on physical observations should if the observations are relevant, result in an underlying larger validity than a model based on only measurement data. A model is only valid within the range it has been verified [32], where verification is done by comparing the model to real-world measurements. To base the models on fundamental understanding of the physics, it is intended to capture the behaviors of the machines better than with empirical models based only on measurement data. A force-conditioned crusher is a crusher that will exert the particles to a specific force, compared to machines that exert the particles to a fixed compression (form-conditioned) or give the particles a velocity (energy-conditioned). The two later modes of crushing have been explained by Evertsson and Lee [15, 27]. An example of a force-conditioned crusher is the HPGR [52].

R.Q. 2: How can fundamental models of minerals processing equipment be developed in order to handle machinery with fast dynamic behavior?

Fundamental models are aimed to describe the inner workings of the crusher. The crushing process is fast in many cases, and to accurately describe the process, the fast dynamic behavior needs to be resolved.

R.Q. 3: How can material storage units be modeled in a process simulation environment?

Material storage units are used within processing plants to act as buffers and smooth out variations and ensure a stable operation. Correctly operated and used buffers can improve operations and increase the stability of the interconnected processes. Knowing and predicting the future states of a buffer or storage unit is important for the control and operation of the overall circuit.

R.Q. 4: How can process models of circuits and plants be calibrated efficiently?

Process models of circuits and plants need to be calibrated to become useful as stated by Steyn and Brown [45], additionally re-calibration will be needed over time to maintain correspondence. A complete process model contains many parameters which need to be calibrated to a few measurements. An under-constrained problem such as these calibration problems can be very costly and time-consuming. More efficient methods of calibration than ad-hoc and manual methods are important to develop.

R.Q. 5: How can a minerals processing plant's degree of robustness be studied and quantified?

A robust plant is insensitive to variations up to a certain degree. This question targets how the robustness property can be studied.

R.Q. 6: What consequences do robustness studies have on plant design?

What is it that makes certain plants robust, and how can plants be designed in order to be robust? What should be aimed for and what should be avoided.

R.Q. 7: How can models based on fundamental principles be used to improve plant control?

This question targets if there are synergies between fundamental model development and the development of control algorithms.

R.Q. 8: What methods are used for transitioning from the high fidelity modeling domain to the control modeling domain?

What methods can be used to develop control models, given that information about a high fidelity fundamental model is available for the specific unit?

Summarized answers to the research questions can be found in Section 7.1.

Chapter 3

Scientific approach

The scientific approach used in this research is explained in this chapter.

The research carried out at the Chalmers Rock Processing Systems (CRPS) research group is problem-oriented. The group has its roots in product development and specifically, machine elements. The research approach is problem-oriented, and for the work within this thesis, the problem-oriented approach has been used. The approach has previously been described by Evertsson [15], and Hultén [24]. The approach has been adopted to the topic of dynamic model development and applications thereof. The workflow when using this approach is illustrated in Figure 3.1.

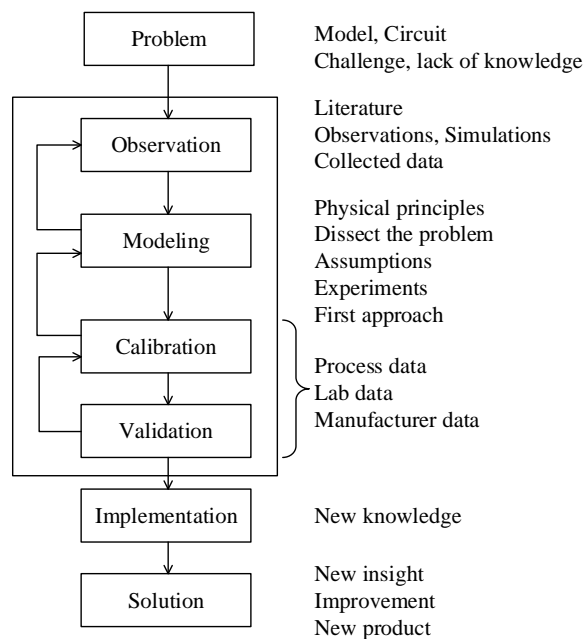

Figure 3.1: A graphical illustration of the research approach used in this research.

A problem-oriented approach is rooted in the need to solve an identified problem. The focus is mainly on the solution to the problem rather than the method to arrive at the result. The specific details of the method vary with the problem type. The general approach assumes that more knowledge about the problem, process or unit will help solve the problem at hand. In other words, more understanding on a required adequate level is something positive. To describe the process illustrated in Figure 3.1, the approach starts with a problem, a need for a new product or a knowledge gap. For all problems and tasks, it is essential to thoroughly study the problem and task to be sure the understood problem is the problem that needs to be solved. After that, the research loop starts, including activities such as literature review, observations, and simulations to build a knowledge base. This base is further used to establish what physical principles could be used and section up the problem into suitable sized parts. Creating sub-problems or functions, each part can be tested separately and verified. This is especially helpful in debugging and development. After the initial model or solution is developed, the calibration and validation can start. Important with the calibration and validation procedure in terms of developing models is to separate the data sets, i.e. in a data set for tuning and a separate data set for validation. In some cases, there is a lack of data, and then the model can not be claimed to be validated, just calibrated.

The entire research method is iterative in nature, and models and solutions are updated and improved over time. Once a new model or solution is developed, it is implemented and evaluated if it can solve the posed problem or knowledge gap. For the research, the purpose is now insights and gaining a better understanding. Commercialization or productization is a later step, however equally important as the research step. The final step is where the utilization comes in, and the research is value-adding for society.

For the modeling and implemented applications within this thesis, the approach has not been limited to how the models can be structured or what tools to use. However, as a general rule, the more straightforward tools and structures that are used, the better. Simplicity has many advantages, for example, simulation speed, debugging, and possible translation into other coding languages. The mindset of using the simplest possible approach is also beneficial when it comes to control modeling. For the process control parts of this thesis, the aim is to apply known techniques rather than inventing new schemes. In control theory, there are many techniques available for linear problems, and in general terms, those are easier to apply than the non-linear methods.

A systematic way of thinking is applied on top of the problem-oriented approach presented above. The systematic way includes a top-down perspective, always keeping in mind the bigger picture. The systematic approach helps divide the overall problem into sub-problems that can be solved separately. This is used especially in the modeling part where problems are dissected, as shown in Figure 3.1. The systems approach also has to be applied as humans are involved in real-world plants' operations. Humans are part of the bigger system, for example, around the asset, the software, and the plants as a workplace.

Chapter 4

Theory

This chapter introduces a few topics, which helps the reader to understand the work presented in this thesis.

4.1 Modeling of comminution and classification systems

Comminution modeling has historically almost exclusively been done with steady-state simulators. A continuation of steady-state modeling and a more detailed modeling approach is dynamic modeling, which this thesis will be focused on. In this section, some background to both types of modeling approaches will be given.

Steady-state modeling takes a flowsheet and uses the nodes to balance the mass flow by iterating until all streams have reached convergence. Steady-state models do not contain elements that cause delays, accumulation or include process control related functionality. The simulation will yield one answer for the mass flow in each stream and one particle size distribution. In Figure 4.1 the same circuit flowsheet is drawn for both a steady state simulation and a dynamic simulation. A major difference in the results from the simulation of the two flowsheets is the type of data that is generated. From the dynamic flowsheet, the data is a series of values over time, while for the steady-state flowsheet there will only be one value. A dynamic simulation generates considerably more data and the amount of data is proportional to the simulation length. A full description of the difference is done by Asbjörnsson [1]. Further, since dynamic simulations include more elements of the actual circuit than the steady state simulation, for example, materials handling, controllers, interlocks, variations, machine wear to mention a few. The effort needed to develop, simulate and interpret these models is more time consuming than steady-state simulations. There is a trade-off between the required information and amount of time available that needs to be considered before deciding on which simulation method to proceed with. As this thesis focuses on time dynamic simulations, the topic of steady-state will not be further discussed.

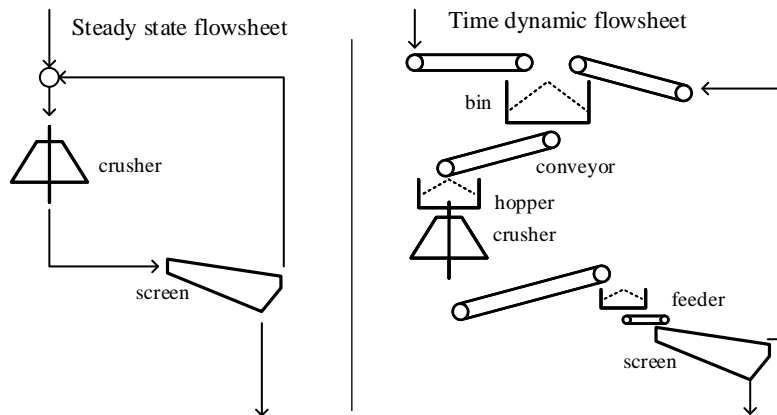

Figure 4.1: Two identical circuits, the left one is the steady-state version and the right is the time dynamic version.

Dynamic simulations can be used in many applications, Asbjörnsson has for example described and worked with, debottlenecking and operator training [1]. Steyn and Brown used dynamic simulations to explore new operational strategies and saved time by using the dynamic model to generate step responses for the advanced control system instead of the actual plant [45]. Legare [28] have presented a framework similar to Sbarbaro's work [49]. All these frameworks and simulation platforms have been implemented in MATLAB Simulink. MATLAB Simulink is today one of the accessible choices for researchers. All implementations within this thesis have also been completed in MATLAB Simulink. However, the methods and algorithms can be implemented in any mathematical coding environment suitable for time-varying simulations. Examples of other simulation software that enable these types of simulations are Modelica [35] and Dyssol [54].

4.2 Crushing machines

There are many different types of crushers used in the minerals processing and aggregate industry. In this research two new models are presented, one for the jaw crusher and one for the high pressure grinding rolls (HPGR) crusher. The basics of these two crushers will be explained in this section.

4.2.1 Jaw crushers

A jaw crusher is most often a type of primary crusher handling rocks with top size of 1500mm down to 500mm for a full sized crusher. The capacity range of an industrial sized jaw crushers is between 30 and 1200 tons per hour [57]. The jaw crusher is a workhorse and can be found in both fixed installations and as mobile crushing units.

A principal illustration of the crusher is shown in Figure 4.2. There are two plates, one fixed and one moving. The moving one is driven by an eccentricity on the shaft, which the fly wheel is mounted on. The rock material is fed in between the two plates compressed repeated times as it falls further down into the chamber. Product size control is implemented by setting the gap between the two plates at the bottom of the crusher. Jaw crushers come in two different types, the single toggle crusher and the double toggle crusher [57]. The first mathematical models of jaw crushers were developed in the 1950's, by for example Gaudie [21]. The focus in these early model attempts were mainly capacity predictions. Later models have also focused on energy consumption [29], linear wear [31] and jaw motion [40].

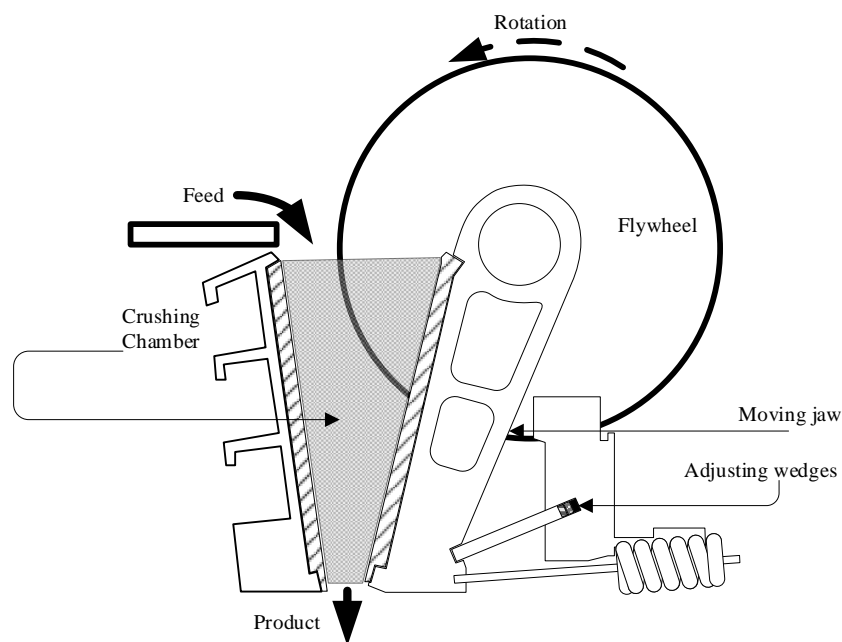

Figure 4.2: Schematic illustration of a jaw crusher by J. Quist.

4.2.2 HPGR

The high pressure grinding rolls (HPGR) crusher originates from the roller crusher and was developed in Germany during the 1980's by Prof. Klaus Schönert [52]. The reasoning behind the development started with Schönert classifying different means of comminution, concluding that the most efficient mode of breaking rock is single particle breakage (one rock at the time, with one or between two contact points). The second most efficient mode is inter particle breakage (many rocks at once, many more contact points), which is also referred to as bed comminution [50]. An explanation of single particle and inter particle comminution is given by Evertsson [15]. A schematic illustration of an HPGR is shown in Figure 4.3. The HPGR machine is a roller crusher equipped with hydraulic cylinders pushing on the floating roller (left side in Figure 4.3) towards the fixed side. Pressing the floating

roller against the fixed combined with the rotation of the rolls creates a compressed bed of rock when material is passed between the rollers. Both rollers are rotating with the same speed but in opposite directions. The rock is fed from the top in between the two rollers and subsequently compressed. The high stress causes the rock to break and if compressed to a certain degree it is claimed to initiate micro cracks in the rock, which have shown to be beneficial in downstream comminution and recovery processes [36]. Due to the very high pressures the roller wear is significant and most HPGR rollers have tungsten carbide studs on the surface to protect the actual roller body. The roller surface is different compared to the older traditional smooth roller crushers. The HPGR is a crusher operating on material smaller than 50 mm top size for large machines. The capacity can be adjusted by setting the roller speed and the maximum capacity is above 3000 (tph) for large units. For a unit with installed variable frequency drives (VFD) connected to the motors, the roller speed can be changed online, which is also the case for the hydraulic pressure setting. Roller speed and pressure are the two main manipulated variables¹ that can be used to control the operations of the HPGR.

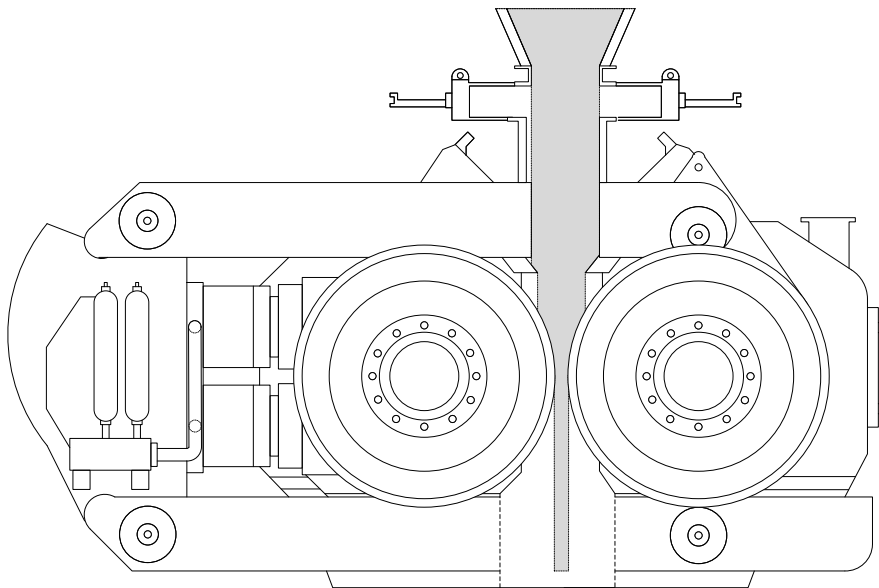

Figure 4.3: Schematic illustration of a FLSmith HPGR, by J. Quist [44].

The HPGR has been subject to extensive modeling. The background models were developed by Austin for roller crushers with soft feed materials, such as coal [4, 3]. After the appearance of the high pressure grinding rolls crusher Schönert and Feurstenau published multiple papers on modeling attempts [52, 20, 51]. Later steady-state models appeared from for example Benzer and Ardogan [10, 5] and Morrell [38]. Modeling of the HPGR has also been attempted with DEM² by, for

¹A manipulated variable is a variable that can be changed for control purposes.

²Discrete element method, a particle simulation method

example, Quist [44], and Barrios [8, 7]. Research on industrial HPGR applications have been demonstrated by Powell [41], Daniel [13], Rule [47] and Herbst [23].

4.3 Storage units

Storage units are used as buffers in many industrial processes to minimize the effect of variations. Buffers are used in the manufacturing industry to some extent but ever more so in process industries, such as chemical, energy, and minerals. In minerals processing they come in different shapes and sizes, for example as round silos, square and rectangular bins, hoppers and stockpiles of various shapes. Rock particles that fall into a pile form a bed with a surface shape similar to a cone. Because of how rock in a storage unit behaves regarding the angle of repose, formation, and segregation, it is of interest to understand these units from a process point of view. Figure 4.4 is a picture of a small stockpile shown under a conveyor from a mobile unit at an aggregate plant.



Figure 4.4: A pile of rock at an aggregate plant. The rock is picked up by a front loader.

Modeling of stockpiles has been of interest for applications within coal mining and storage of mined coal. This is because large quantities of coal may self ignite if stored improperly. Salinger explains the background of the problem and how it can be modeled [48]. Modeling has also been of interest for mathematicians, and in this case of sand piles by, for example, Puhl [42]. The models developed by Puhl are based on self-organized criticality, which was proposed by Bak [6]. Lu developed a model which simulates each particle in a grid, and the model was aimed at describing reclaim stockpiles [33]. DEM have been utilized for a few applications, Gonzalez has simulated filling and emptying silos [22], and Cleary have studied hopper discharge [11]. DEM is a good tool for modeling flow and storage, however not practical

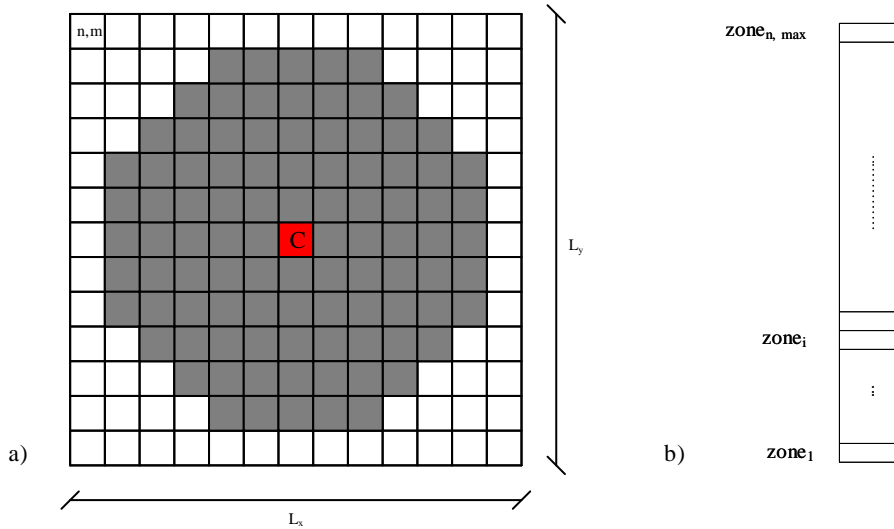

Figure 4.5: a) Grid structure of a bin model that can track material in 3D, with a grid in the horizontal plane and b) a stack in the vertical direction in each grid cell.

in terms of process modeling as DEM is too computationally heavy for real time simulations. Asbjörnsson have developed a model of a storage unit in 2D for bins and stockpiles [2]. A storage unit model that can do material tracking needs to track in 3D with a grid in the horizontal plane as illustrated in Figure 4.5a and vertically in a zone structure as in Figure 4.5b

4.4 Model based control algorithms

In this thesis the applied advanced control algorithms have been linear model predictive control. The topic of linear Model Predictive Control (MPC) will be briefly explained here to help the reader better understand the later application of it. The predecessor to MPC, Dynamic Matrix Control (DMC) was developed by Cutler [12] at the Shell company, in Houston, Texas, to advance the control of petrochemical plants. The concept was brought to light as computers got more and more powerful during the second part of the 20th century. The idea with the control strategy was to be able to handle large MIMO³ control problems effectively, especially with systems that have long lagtime. Previously with PID⁴-control the only way to control slow systems was to make the integral part of the PID-controller small. DMC was based on a least squares problem, which in turn tried to minimize the error over time for a MIMO system. As well as being influenced by the theory and idea behind Receding Horizon Control (RHC) [37]. DMC later evolved along with a similar method called Generalized Predictive Control (GPC), where DMC utilized step response models in

³Multi input multi output

⁴Proportional, integral and derivative control, a feedback control law.

the controller and GPC transfer functions. The history of DMC, GPC and MPC is described by Morari [37]. DMC was very successful and is implemented in some form in almost all new petrochemical plants today.

MPC is a control strategy that calculates future inputs and simulates the system to find the optimal inputs given a certain objective. A graphical representation of this is shown in Figure 4.6. The reference trajectory is the target the controller aims to

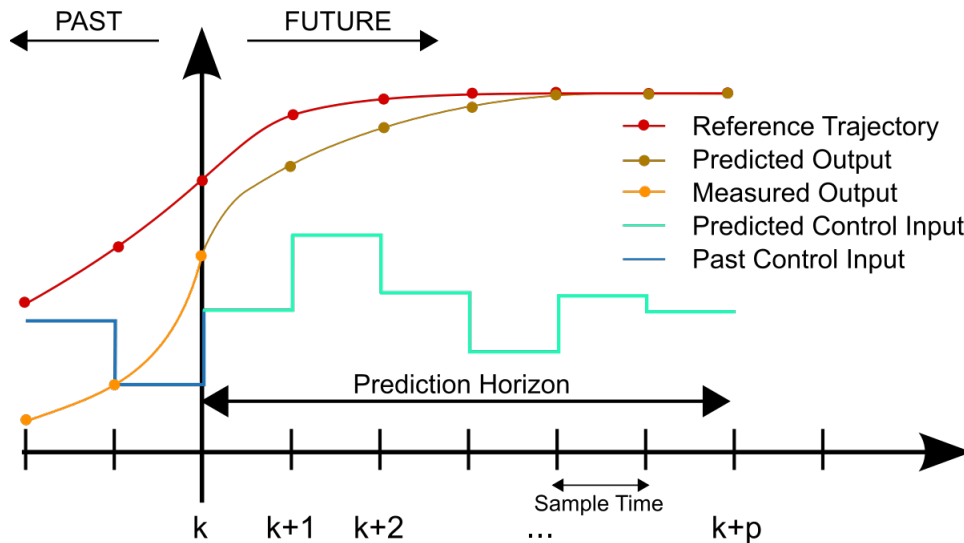

Figure 4.6: A graphical representation of MPC by M. Behrendt. licensed under CC 3.0

hit. The target could be static or moving, depending on the problem. The predicted output is the output of the model predictions within the controller. The measured output is the measurement from the plant or the physical unit being controlled. The predicted control input is the sequence of optimally calculated controller inputs based on the controller model and measurements at time k . The prediction horizon is the number of steps (p) into the future the controller is making predictions for. One of the properties that makes the MPC scheme successful is that the calculation of the optimal control inputs happens every sampling instance, but only the first input is applied to the system. In other words, only the input at time k is applied to the system, the rest of the values are discarded, and when time $k + 1$ happens the same optimization problem is solved again for p steps into the future. In some cases the control horizon and the prediction horizon could be different, in that case the prediction horizon should be similar to the settling time of the system and the control horizon the rise time of the system.

MPC in this thesis refers to the academic version based on the state space formulation of the control model. A linear discrete state space model is formulated as shown in Equation 4.1, where A is the model for the states and B is how the inputs affect the states. Using the state space formulation allows for mathematical analysis with linear algebra of the properties for the problem, including the possibility to

utilize one of multiple available solvers for solving sets of linear equations.

$$x(i+1) = Ax(i) + Bu(i), \quad x(0) = x_0 \quad (4.1)$$

For the implementations within this thesis, the solver ForcesPro [14] was used. The optimization problem is shown in Equation set 4.2 and is on the form needed for an implementation in ForcesPro. First inputs are shifted to deviation form and the notation is made more compact, as shown in Equation 4.3. The shift to deviation in the control inputs allows for constraints on the rate of change of the control inputs, which is useful in some applications to avoid large variations in the inputs. Equations 4.4 and 4.5 defines the model within the controller, essentially being the same as Equation 4.1 but in the augmented form to fit with the z vector used in the solver. The matrices D_i and C_i can be different for different i as the dynamics of the system change for different operating points. The solver requires z_1 to be known as an initial condition.

$$\begin{aligned} \text{minimize} \quad & \sum_{i=1}^N \frac{1}{2} (z_i^T H_i z_i + f^T z_i) \\ \text{subject to} \quad & D_1 z_1 = c_1 \\ & C_{i-1} z_{i-1} + D_i z_i = c_i \\ & z_{i,\min} \leq z_i \leq z_{i,\max} \end{aligned} \quad (4.2)$$

$$z_i = \begin{bmatrix} \Delta \mathbf{u}_i \\ \mathbf{x}_i \\ \mathbf{u}_i \end{bmatrix} \quad (4.3)$$

$$C_{i-1} = \begin{bmatrix} \mathbf{0} & A & B \\ \mathbf{0} & \dots & I \end{bmatrix} \quad (4.4)$$

$$D_i = \begin{bmatrix} B & -I & 0 \\ I & 0 & -I \end{bmatrix} \quad (4.5)$$

This MPC formulation allows for constraints on states, inputs and rate of change of the inputs. The control objective is defined by matrix H_i and the vector f_i , where H have to be positive definite. The objective can be quadratic or linear. The type of objective is an important property in order for the problem, such that there exists one minimum, which is the global minimum. The complete set of requirements are given by the solver manual provided by Embotech for the ForcesPro solver [14].

4.5 Stability and robustness of plants

The stability of a process determines if its output stays bounded for a bounded input signal. Stability is part of fundamental control theory. This theory is covered by Lennartson [30] and more specifically in regards to robust control by Skogestad [53]. Robust control concepts can be used to analyze stability and performance properties

of closed loop systems with uncertainties within them. Uncertainty can be in the form of both model structure such as values of parameters and disturbances. To analyze minerals processing related processes with robust control methods, linear models have been utilized in the studies presented in this thesis. The Nyquist stability criterion [53] says a system is stable as long as its Nyquist plot does not encircle the negative one point in the Nyquist plane. If uncertainties are introduced the Nyquist plot of the loop transfer function will change. In Figure 4.7, $L_n(j\omega)$ is the nominal loop transfer function. The distance $|1 + L_n(j\omega)|$ is how far from unstable the loop is at frequency ω . The loop transfer function includes uncertainties in some of its parameters and two possible perturbed systems are shown in Figure 4.7 as L_1 and L_2 . Skogestad [53] describes how multiplicative uncertainty can be handled to analyze the stability from an algebraic point of view.

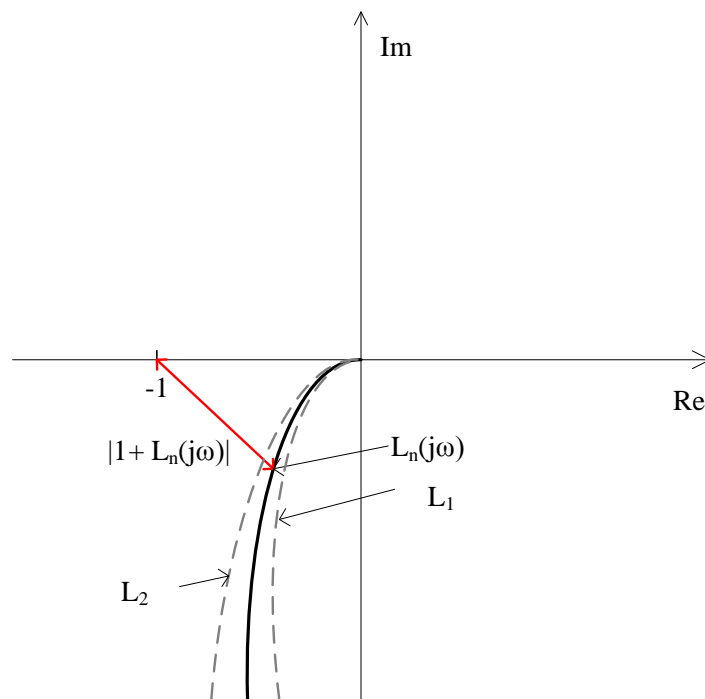

Figure 4.7: A Nyquist plot of a nominal loop L_n and two perturbed loops L_1 and L_2 . The red arrow indicates the distance from instability for a specific frequency.

This analysis can investigate how different parameters of minerals processing related systems behave concerning stability. MATLAB has implemented functions that calculate how the stability changes for different model parameters. The calculations are done within the robust control system toolbox [34].

Chapter 5

Method

In this chapter the methods used in developing this research are explained.

From a context point of view, the modeling is assumed to be the basis in this research, and from a top-down approach, the system is viewed as pictured in Figure 5.1. A comminution plant often consists of multiple sub-circuits. These circuits consist of multiple units. In every unit there are different physical events taking place when the unit is operated or used. The modeling approach is rooted in the belief that it is important to understand the physical function or event occurring within the unit. The modeling strategy used in this thesis is to build up a model with as simple blocks as possible. The less complex a phenomenon can be described, the better, both for model understanding, simulation speed, and complexity. Ljung classifies mathematical models in two groups, physical models and identification models [32]. In this thesis most models are of the physical type, however in instances where available data fit well with a certain model approach, identification models are utilized. Using identifications models where appropriate is along the lines of finding the least complex approach to describe something. This idea trails throughout Paper A, B, C, D, F, G and H. This is especially important when it comes to control modeling, where certain methods limit the choice of models.

5.1 Physical modeling

In Paper A, B and F three new equipment models were developed. The jaw crusher model in Paper A was first aimed to be a steady-state model. However, it can be adapted to be dynamic. On the other hand in Paper B, the HPGR model is time dynamic. The models presented in Paper A and Paper B are of comminution machines and will be presented in Section 5.1.1. In Paper F a dynamic model of a storage unit was developed. The model in Paper F is a storage or materials handling model and will be discussed in Section 5.1.2.

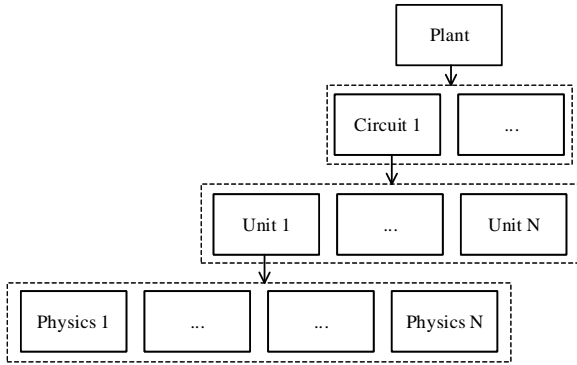

Figure 5.1: The different system levels in modeling of minerals processing plants.

5.1.1 Comminution modeling

The main distinction between the jaw crusher and the HPGR is the working principles of the two crushers. A jaw crusher is a stiff and form conditioned crushing machine, while the HPGR is force conditioned due to the design with a floating roller and gas accumulators. Evertsson and Lee [15, 27] have described the difference between form conditioned and energy conditioned crushing. The stiff form conditioned crushing that takes place in the jaw crusher will always exert the rock to a specific compression, while the force conditioned crushing will exert the particle to a force rather than a compression ratio. If the rock is too hard in the jaw crusher, the crusher may stop. In an HPGR the floating roller will back off, and the distance between the rollers will increase. In both cases the particles will be exposed to a compression at the end, wherein the HPGR this compression depends on the floating roller position. To find the compression ratio for an HPGR the floating roller position needs to be solved for. The two different model structures for both the jaw crusher and the HPGR are shown in Figure 5.2. The main difference between these two model schemes is that in order to solve for the unknown force within the HPGR model, the predicted force from the previous iteration is fed into the next iteration of the model. The predicted force can then be used to solve the equation for the force balance of the floating roller. The force balance is solved within the dynamics block of the model. The dynamics block keeps track of where the floating roller is positioned and its movement in the horizontal direction. The equation of motion for the floating roller in one dimension can be derived from Figure 5.3-b). The resulting equation is shown in Equation 5.1. By solving the differential Equation 5.1 in time and for x , which is the relative position of the floating roller to the fixed roller, the compression of the material can be calculated. This was demonstrated in Paper B.

$$m\ddot{x} = \sum F = F_h + (-\rho\dot{x}) + (-kx) - F_{roller} \quad (5.1)$$

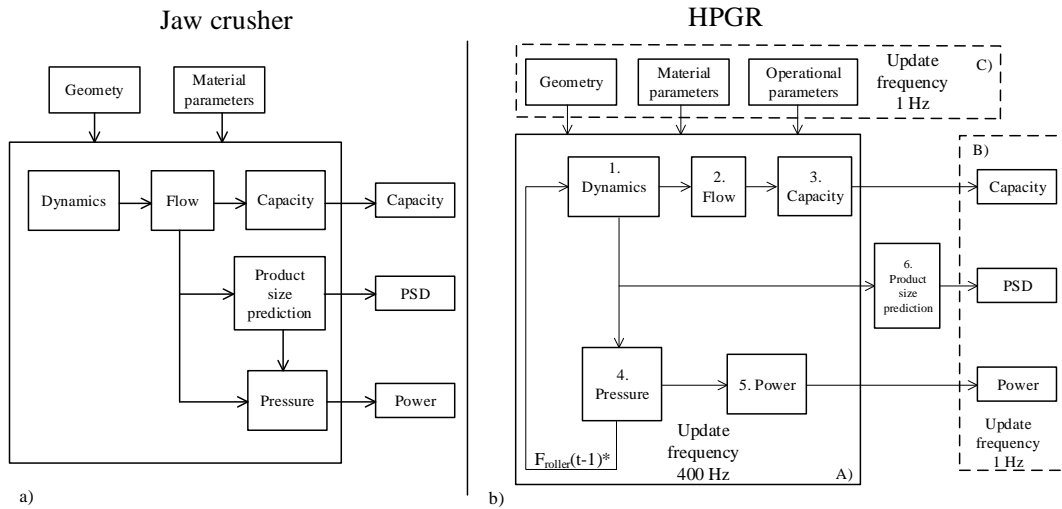

Figure 5.2: a) Jaw crusher model b) HPGR crusher model structures. The flow of data is indicated by the arrows.

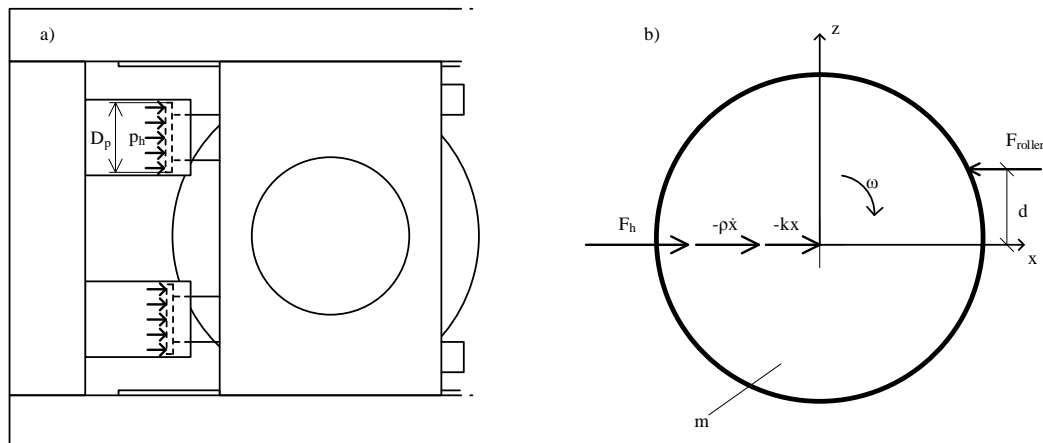

Figure 5.3: a) A Standard frame HPGR with the hydraulic cylinder illustrated, two cylinders on each side of diameter D_p and the pressure p_h . In b) the free body diagram of the floating roller is shown.

The difference between the forces F_h and F_{roller} is the resulting force that gives rise to movement of the roller. The stiffness (k) and damping (ρ) terms are present to stabilize the model. This was needed since the available data resolution for the validation data was too low and created large step changes. The model can be executed with process data, in this case the hydraulic pressure (F_h) and roller speed (ω), or it can be operated as a stand alone model.

In both Paper A and B the power draw is calculated by splitting up the crushing zone in discrete sections. For the jaw crusher, the material sees repeated compressions,

while in the HPGR the material bed is exerted to one continuous compression. In Equations 5.2 and 5.3 the calculation of the nominal power draw is stated for both crushers.

$$P_{JAW} = f \sum_{i=1}^n \frac{P_i Area_i S_i}{2} \quad (5.2)$$

$$P_{HPGR} = \omega T = \omega \sum_{j=1}^{25} \sum_{i=1}^{n_{zones}} c_{scale,j} \frac{F_{comp,i,j}}{\cos(\alpha_i)} R_{roller} \mathbf{sign}(\alpha_i) \mu \quad (5.3)$$

The power draw predictions share the idea that the forces associated with the crushing should correlate to the power draw of the machine. The implication of this is that the power draw predictions are nominal, and additions for no-load and losses need to be included to get the actual draw. For the jaw crusher in Equation 5.2, f is the frequency of the shaft [Hz], n the number of crushing zones, P_i the pressure from the rock in each crushing zone [Pa], S_i the compression distance in each zone [m]. Assuming the force is linear with the compression distance, the work for each crushing zone is calculated with and the total work is the sum of all crushing zones. The power draw can be calculated by multiplication of the work per cycle and the number of cycles per unit time (f). For the HPGR in Equation 5.3, the required power draw to rotate the rollers is the total torque on the roller around the axis of rotation times the rotational speed of the roller (ω). The total torque can be calculated by taking the tangential force component times the radius of the roller (R_{roller}). The tangential force can be calculated by taking the normal force onto the roller divided by the cosine of the angle from the normal plane. The factor $c_{scale,j}$ is there to deal with if the crusher has cheek plates or not. The cosine function is positive for both negative and positive angles; therefore, the sign function is used to model the extrusion effect of the particle bed as the bed is relaxed. The bed that has passed the horizontal plane parallel to the rotational axis of the roller is pretensioned and will partly elastically relax. The relaxation effect creates a torque on the roller with opposite sign from the one needed to compress the bed. By comparing process data and the predictions from the model, the utilized friction μ can be calculated.

In comminution modeling prediction of the particle size distributions (PSD) is an integral part of the model. Both models in Paper A and B utilize the framework developed by Evertsson [15]. The framework is illustrated in Figure 5.4.

In order for the PSD framework to be compatible with the model by Evertsson for both the jaw crusher and the HPGR, the comminution within each machine needs to be translated into discrete compressions and s/b^1 . In Paper A the material sees multiple compressions as it passes through the chamber, making it more similar to the cone crusher, while in Paper B the compression is one single continuous compression. The particle size prediction is done according to Equation 5.4. The breakage parameters can be retrieved by doing compression tests with a piston and die as described by Evertsson and Lee [15, 16, 27]. The construction of the matrices,

¹ s is the compressed distance and b the initial distance, s/b is the compression ratio as defined by Evertsson [15]

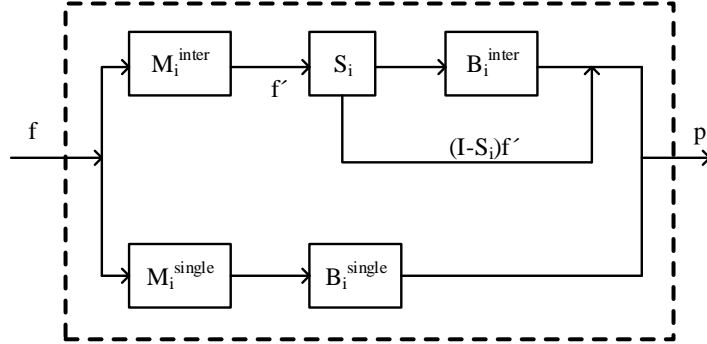

Figure 5.4: Schematic block diagram for how a feed size distribution f , is transformed to a product size distribution p

M^{inter} , M^{single} , S , B^{inter} and B^{single} have been described by Evertsson, Lee and others [15, 16, 17, 27].

$$p = (M^{inter}[SB^{inter} + (I - S)] + M^{single}B^{single})f \quad (5.4)$$

In Equation 5.4, f is the feed vector, containing the frequency of the different size fractions and p the product after a pass through the crusher, also in the frequency of the different size fractions. The breakage matrix B and selection matrix S are updated depending on the current compression ratio the feed is exposed to. M^{inter} and M^{single} are the mode matrices, which decides if the particles are exposed to inter-particle breakage or single particle breakage. This decision depends on if the particles in the feed are larger than the gap or not. All those sizes which are larger than the gap are exposed to single particle breakage and the rest to inter-particle breakage.

5.1.2 Modeling of storage units

In Paper F a time dynamic model of a storage unit is presented. The model is structured around the idea that the particles have a bulk behavior and can be modeled as a block where each block has its specific properties. An area is defined in the model as in Figure 4.5 with a grid in the horizontal plane and a vertical stack structure in each grid cell. Material enters the unit from the top and is withdrawn from the bottom. When material is poured into a spot it will eventually spread out to form a cone. This behavior is discretized in the model in presented in Paper F. In the list below the order of operation is noted for each time step of the model. In step 1 and step 2 material is added to or withdrawn from the assigned cells. After that, in step 3, the model will loop over all cells starting from the center cell and check the height relative to its neighbor. If the slope between two cells is larger than the

angle of repose of the material then material is transferred, this process is described in the diagram in Figure 5.5.

1. Handle inflowing material
2. Process outflowing material
3. Transfer material between cells

The flow diagram in Figure 5.5 is an approach to approximate what happens within a storage unit over time. The events are continuous in the real world however, in order to function as a process model, the model needs to be quick and should not include any iterative calculations that needs to converge. The idea behind the model is to do small calculations often, and thereby not having to be as precise as in a DEM-simulation wherein all interactions are resolved for every time step.

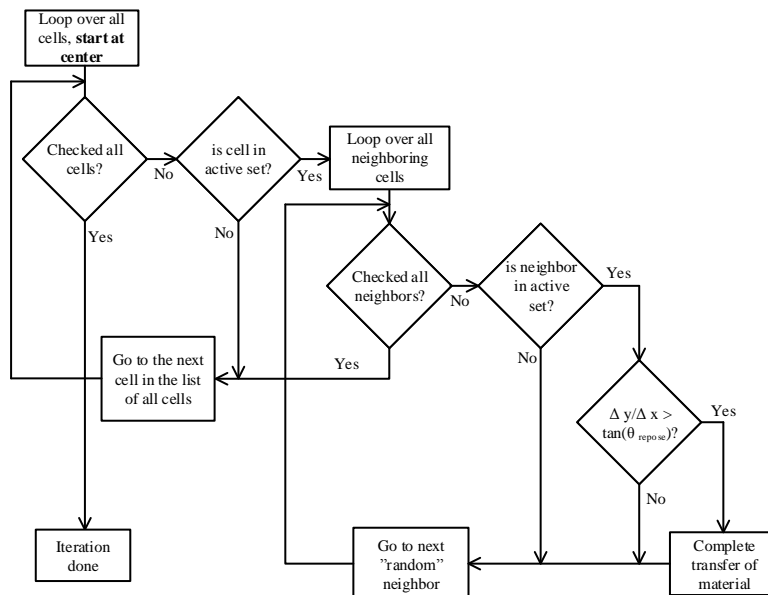

Figure 5.5: The flow diagram of the transfer process within the storage model.

Transfer of material can only take place on the surface of the storage unit and the material within one cell and zone is assumed perfectly mixed. How the zones are structured are shown in Figure 4.5 b). The model is based on a few approximations of reality and houses only two tuning parameters, the angle of repose and the transfer rate. The transfer rate determines how much material of the actual height difference between two cells that should be transferred. Worth noting is that the grid the model is based on can be modified in the way that only some cells are inactive and transfer to inactive cells is not possible. This can be used to create geometries of bins and silos. The full grid is used for simulating stockpiles. Another aspect in order for the model to distribute transfers equally over time, the neighbors are checked in a random order.

5.2 Process modeling

Process modeling in this thesis has taken multiple different forms. In Paper E an entire circuit with high fidelity model were studied. Paper H deals with the method of tuning a high fidelity circuit model. In Paper D and Paper G the processes are modeled from a control perspective, and only the most fundamental aspects of the circuit's behavior are considered. The methods used in Paper D and Paper G will be presented first, followed by the methods in Paper E and H.

5.2.1 Robustness and circuit analysis

A coarse comminution circuit can contain multiple stages of crushing. As shown in Figure 5.6 a), in this flowsheet there are two stages. The stages are separated by a larger intermediate bin. For the circuit to operate continuously the two stages need to be operated at the same capacity over time. The most material that can be processed is if both stages operate at the highest rate possible all the time. Paper D deals with how the two stages need to be balanced in order to operate well as a complete circuit, while Paper G formalizes how one stage can be designed and how different stage properties affect measures as stability and peak system gain (referred to as performance in Paper G). Paper G uses robust control theory to quantify the stability and performance margins for a specific set of parameters and Paper D uses exhaustive simulations and induced variations. High fidelity process models can be used for most tasks regarding process and control modeling. However, for a first analysis and more complicated setups, simpler models could be useful. The high fidelity models in Paper A and B are between 10-100 times faster than real-time. If there is a need to run hundreds of simulations of different cases, a high fidelity circuit model might be unfeasible to use. In that case the types of models used in Paper D and Paper G could be useful.

In Paper D each of the two stages is considered to be operated at a constant CSS setting, and the crusher is operated in choke-fed condition. Choke feeding is standard operating procedure for cone crushers and makes the crusher behave like a throttle valve. The throttle valve behavior at constant CSS results in constant capacity for the crusher. There are always variations, especially when processing a natural material like rock. The implemented simulation model in Paper D is the flowsheet in Figure 5.6, in a) as the actual flowsheet and in b) as the simplified model. In part b) of Figure 5.6 the model setup can be studied. In order to build the simplified model, the approach is to look at the elements in the circuit and their behavior to determine what is the simplest way to describes them while still capturing their core behavior. In this specific case, the crushers are modeled as throttle valves, bins as tanks, and the screens as splitters. Conveyors are modeled as pure time delays. The control logic is implemented, including PI-control of the flow between the sub-circuits as well as interlocks and startup delays when interlocks are activated. The full setup and all parameters can be found in Paper D. The model in b) can be simulated at 1000-10 000 times faster than real time. In Paper D, the capacity of the crusher, the bin sizes,

and the inflow were varied in different ways. The throughput of the complete circuit was measured by studying the available inflow relative to what amount that made it through during an eight hours simulation. The amplitude of the variations were changed to different levels to see the effect on the circuit throughput. The motivation for doing the analysis in Paper D was to approach the modeling and simulation problem from the opposite side compared to the commonly used approach of very high fidelity models based on survey data and lab tests. In the work presented in Paper D, the focus was rather on the variations introduced than the model accuracy. The approach can be used to see the effect of varying bin-sizes, ill-designed circuits and to what degree a design can handle material or incoming variations.

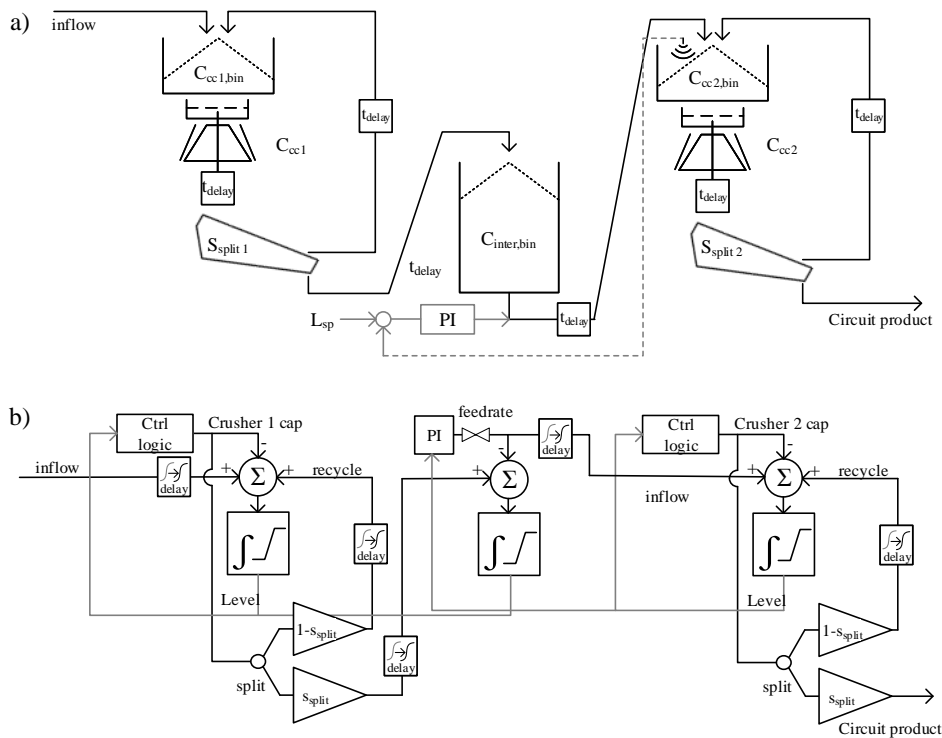

Figure 5.6: a) Flowsheet of the originally modeled plant, and b) the flowsheet implemented for the simulation of the plant

As demonstrated in Paper D, an exhaustive simulation approach could be helpful to understand how the system behaves. However, extrapolating the result into more general terms is difficult. The topic in Paper G is more specific, as it targets the question of how to generalize the influence of parameters within a closed crushing stage. In Paper G a more detailed view of a crushing stage is used, the flowsheet is visualized in Figure 5.7 (Left). To operate the circuit satisfactory and continuously two objectives have to be fulfilled, first there needs to be available material in the bin and, second the crusher's hopper needs to have a consistent level (choke fed). Utilizing the modeling ideas from Paper D a linear system with delays can be formulated, which results in the block diagram in Figure 5.7 (Right). The models in the block diagram are written in terms of the Laplace variable s and r_1 and r_2

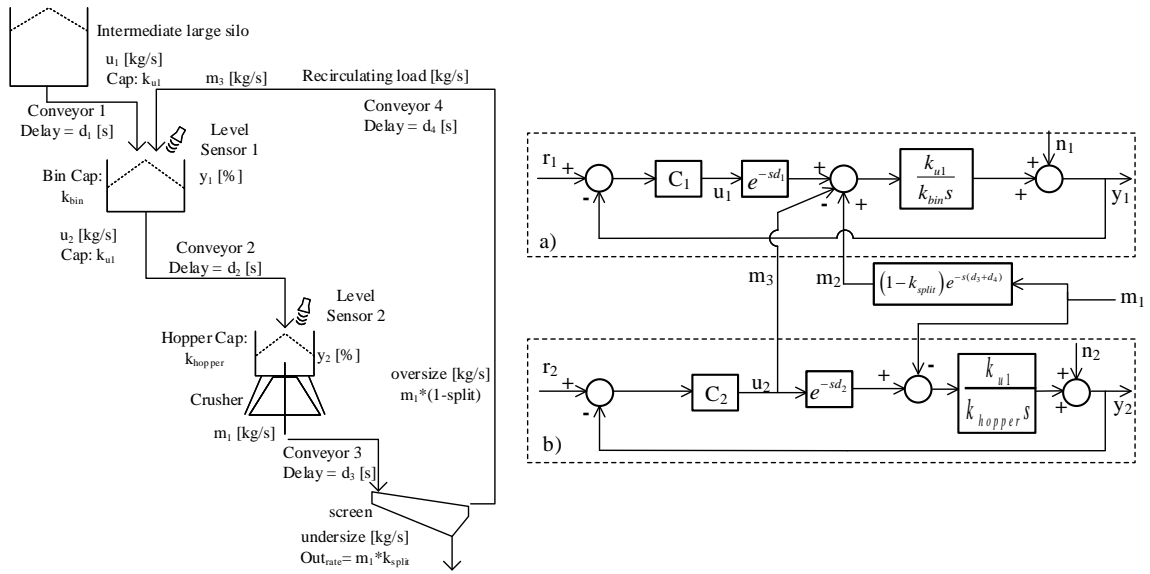

Figure 5.7: (Left) a more detailed view of a closed loop crushing stage compared to Figure 5.6-a). (Right) The associated control loop diagram of the closed loop crushing circuit from Paper G.

are the input references, n_1 , n_2 and m_1 are input disturbances and y_1 and y_2 are the outputs. The controllers C_1 and C_2 are standard PI-controllers. Since the circuit has only one-way interconnectivity between the dashed boxes a) and b) in Figure 5.7 each of the loops can be tuned and made sure they are stable individually.

To account for that the linear models are not perfect descriptions of the circuit, parametric uncertainties have been introduced for the parameters; k_{u1} , k_{split} , k_{bin} and k_{hopper} . Skogestad describes how parametric uncertainty can be used to analyze stability and performance margins of closed loops systems in a robust way [53]. The analysis builds on robust control theory. To numerically calculate the stability and performance margins relative to the level of uncertainty in the introduced parameters, MATLAB's robust control system toolbox was used [34]. The answers from the toolbox command is in terms of how much more uncertainty the system can tolerate before going unstable or having a gain larger than the performance requirement. The calculated margins along with Bode and step response plots can be used to analyze the behavior of the closed loop crushing stage. The nominal values of the parameters have been varied to study how those changes affect the stability and performance margins.

5.2.2 Circuit modeling and calibration

In Paper E, a high fidelity circuit model was developed, assembled and used for simulations. The general method for developing simulations models of existing plants consists of the following steps:

1. Find documentation and draw a flowsheet of the plant that should be modeled
2. Find or develop all unit models included in the flowsheet
3. Test and tune all unit models separately
4. Assemble all unit models into the circuit, testing can here be done in manual mode
5. Apply existing control functionality, such as PI-loops and interlocks
6. Run the circuit model with inputs for the physical plant and record the simulation model outputs
7. Compare the output from the simulation model with the plant data for the same measurement points.

The list above consists of the method used in Paper E but can be applied to other circuits or problems as well. The list appears linear, but in practice it is an iterative exercise. Developing models that should correspond well both in phase and amplitude over time is difficult. The modeling of a complete plant is a process that can take many months or years. This framework can be utilized to develop models for digital twin applications.

For all brownfield projects involving simulations, model calibration is an important aspect for successful implementation. In Paper H a method is presented to setup calibration of models and the flows in general. The method builds on an idea similar to current laws in electrical circuits and focuses on nodes in a circuit. In Figure 5.8 a general outline of the procedure is shown. Initial calibration of a model requires something to calibrate against, therefore it is important to locate where this data is recorded physically on the plant. Thereafter the circuit should be split into smaller parts as it is infeasible to calibrate all parameters at ones. A small circuit may have 30-40 parameters making it very time consuming and computationally expensive to calibrate them all at ones. When the circuit is split into sub-parts, it is important that they are around nodes and have a clear input/output structure. For each sub-part of the circuit, simplified models are established. The simplified models are then simulated to find the best fitting parameters. This is repeatedly done for all sub-parts of the full circuit. Finally, as a check the updated parameters are collected and checked with the full circuit model.

A practical example of how to split a circuit and generate the simplified model is shown in Figure 5.9 -a) where two feeders are pulling material out of a silo and placing it onto a conveyor. The two feeders needs to be calibrated. The method in Paper H utilizes knowledge about the underlying model that maps feeder speed to output flowrate of material. The model of the feeders can be simplified to the shown block diagram shown in Figure 5.9 -b). Borrowing ideas from Paper D and Paper G to only simulate mass flow. The reduction can be made since the represented model can capture the modeled behavior to a high degree and other additions only marginally improve the predictions.

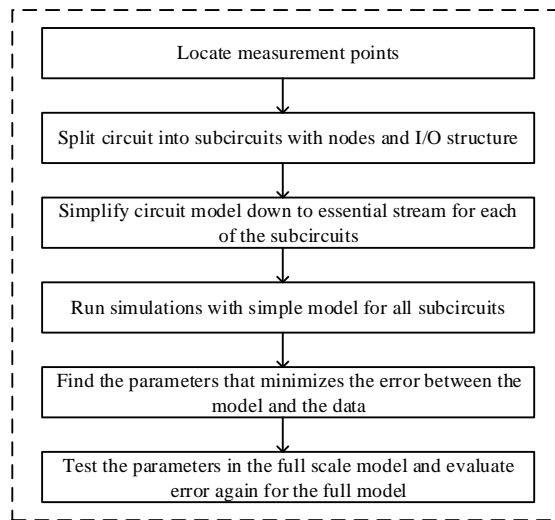

Figure 5.8: The proposed workflow in Paper H for setting up the calibration process of a circuit model.

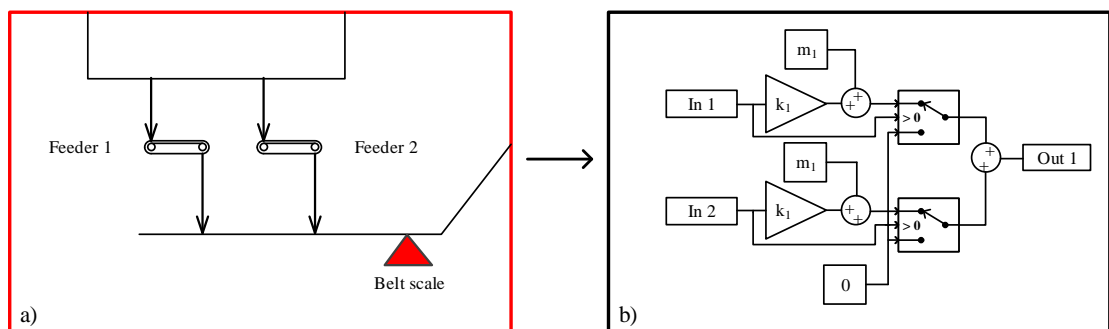

Figure 5.9: a) A section of a flowsheet in detail and in b) the corresponding simplified calibration model

5.3 Control modeling

In Paper C an application of linear model predictive control (MPC) was presented. The circuit used for the study is drawn in Figure 5.10. It is a tertiary crushing circuit that produces a -10mm ball mill feed. The controller was used to control the circuit model developed by Johansson [26] and summarized in Paper E. The simulations ran in the computer, controlling a copy of a physical plant, which was realized as a time dynamic model. The method to set up the controller will describe the controller itself and how to interface and connect the controller with the simulation model. The simulation model is assumed to be available as it was in the case with Paper C.

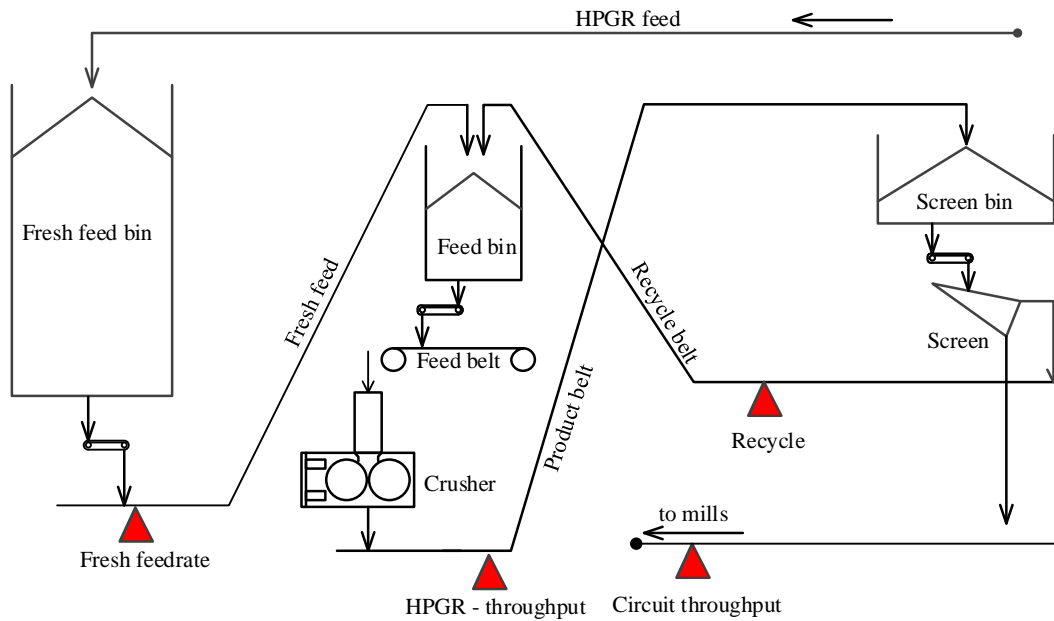

Figure 5.10: The flowsheet of the crushing process that the MPC controller has been applied to.

To set up an MPC for the circuit, the insights from Paper D and Paper G are helpful to identify the control model elements. From Figure 5.10, the following needs to be identified:

- Controlled variables
- Manipulated variables
- Elements to be considered in the controller model
- Elements that are not considered in the controller model

Visually this work is to move from the flowsheet in Figure 5.10 to the flowsheet in Figure 5.12. As described in Paper C, the conveyors are translated to delays, the bins to integrators, and the screens to splitters. The controller model only considers the flow of material, however it can be extended to cover size and other properties if needed. In Figure 5.11 the ideas behind the models in the controller are described. For the conveyor in a) the material enters from the left, it moves one slot per unit time. The material is a packet of a certain mass per unit time. The conveyor needs to run at constant speed for this approach to work, and the length of the conveyor divided by the belt speed determines the delay time. The delay time can then be translated to how many states that need to be allocated for the conveyor. For example, as with the circuit in Paper C and E the sampling time of the controller is 10 seconds. To represent a 180 seconds long conveyor a total of 18 states are allocated in the controller model. In Figure 5.11 b) the screen is illustrated and the incoming material flow is split by a constant factor, in other words multiplied by a constant, corresponding to approximately what portion of the material stream

that is larger and smaller than the screen's apertures respectively. Finally, in Figure 5.11 c), the bins are modeled as a tank or a pure integrator, summing the difference between inflow and outflow. All these types of models can be implemented in a state space model. Furthermore, a sampling time of the controller needs to be chosen, in Paper C this was 10 seconds, implying the controller would solve the optimal control problem once every 10 seconds. Other setting that need to be determined are the length of the prediction and control horizon. The demonstrated case in Paper C used 70 steps for both the prediction and control horizon. The main reason for using a sampling time of 10 seconds and a 70 step control and prediction horizon was that the currently existing MPC used for this installation had those settings.

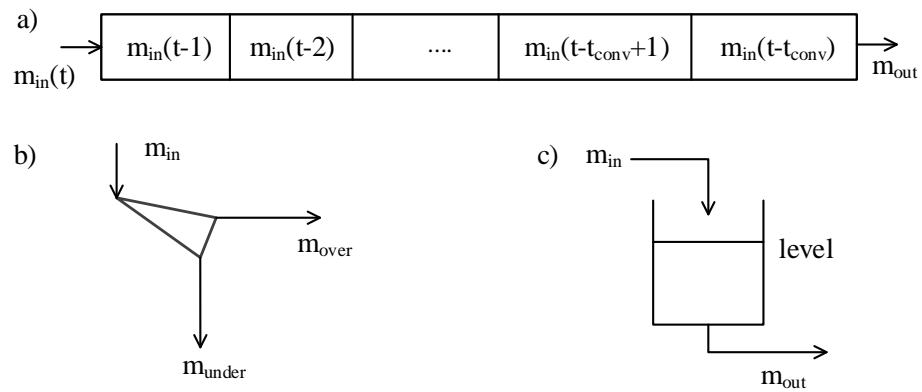

Figure 5.11: An illustration of the different unit models included in the controller model. The conveyor in a), the screen in b) and the bins/silos in c).

For visual purposes the states are marked in the flowsheet in Figure 5.12 and indicated where they are located. The manipulated variables are marked as u_1 , u_2 and u_3 . The manipulated variables were circuit inflow, HPGR capacity, and screen feed rate. Measurement points of the flow of material at the actual plant are indicated by the red triangles. The measurements are taken online using belt scales.

The main reason for developing a controller is to control some objective, and this objective is defined in the matrix H and the vector f . In Figure 5.13 on the left, the non-zero entries in the H matrix and f vector are shown. Based on the control formulation in Section 4.4 in this case the first three entries are penalization of movement of the control setting, and the bottom six entries are to define the objective, which is to keep the two intermediate bins, the HPGR-feed, and the screening bin to 50% level and finally to set a target for the output of the circuit. The objective is implemented according to Equation 5.5.

$$\mathbf{minimize}(x_{66} - 100)^2 + (x_{67} - 100)^2 - x_{64} \quad (5.5)$$

In Equation 5.5 the first two states, x_{66} and x_{67} are the levels in the feed bin and screen bin, which are controlled to a setpoint of 50%. The state x_{64} is the circuit output, and in the formulation, in Equation 5.5 it is being maximized. The location

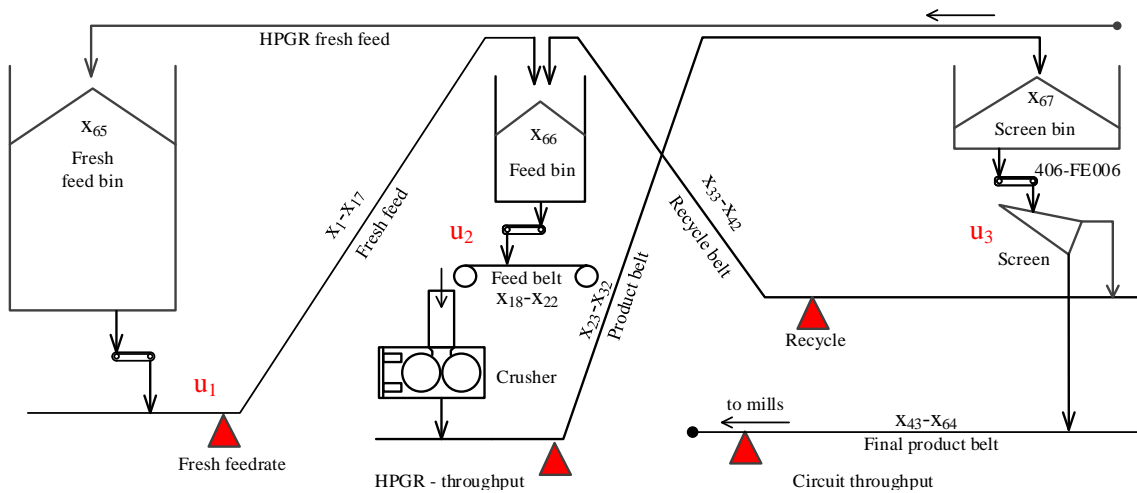

Figure 5.12: The flowsheet of the circuit with the introduced states and manipulated variables for the controller model

of each of the states are according to Figure 5.12. A setpoint can be implemented in the same way as for the two levels, which was done in Paper C. The numerical values entered into the H matrix need to be set so that the controller prioritizes the most important targets. Finding a balance between the numerical values within the objective function is typically done by trial and error. To have a model of the real system is in this case very beneficial as the tuning process does not consume plant production time. The tuning difficulty is acknowledged by Rawling, and Mayne [46].

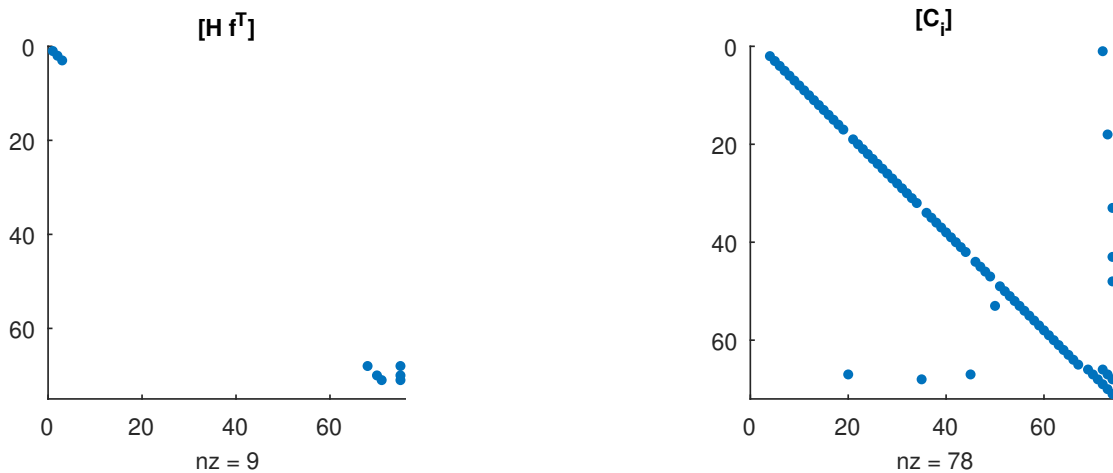

Figure 5.13: Visualization of the non-zero elements in the matrices determining the objective and controller model for the MPC in Paper C.

From control theory, for functional controllability, it is required to have equally many manipulated variables as controlled variables [53]. In Paper C the circuit has three available manipulated variables, making it possible to control three outputs, which in this case is adequate. This is the reasoning behind how the controller is set up to achieve the intended function.

The approach used in this work to connect the controller to the circuit includes a

concept called "setpoint slaving". The MPC will not directly write to the actuators in the model but rather update the PI controllers' setpoints. The setup of the application implemented in Paper C has been explained by Johansson [26]. The setpoint slaving approach is more safe in many cases. In the case where the MPC fails to find a solution to the optimal control problem the PI-loop continues to run with the previous setpoint. This approach is suitable for the slow process modeled in Paper C.

To integrate the controller with the simulation model the following needs to be considered:

- Units of setpoints passed between the controller and simulation model because of different sampling times.
- Initialization of the controller model.
- Passing updated values to the controller model when things change, for example, the screen split.
- Making sure the constraints on the MPC and the PI-loops' limits are set to the same values.
- Allowing the sampling time of the MPC to be the same or slower than the simulation model.

Additionally, which was not considered for the work presented in Paper C or Paper E, start-up and shut down routines are needed. These sequences are needed on an actual plant, where typically the MPC is disengaged, and a sequence of events are executed to facilitate a safe start or stop the plant. From a safety point of view, it is not needed in a simulation study. However, correctly implemented, it could be used to improve the start-up performance of the plant.

Chapter 6

Results

In this chapter, the results of the research are presented in a summarized form. The results are divided up into the subcategories, equipment modeling, process control, and circuit modeling

6.1 Equipment modeling

In Paper A and Paper B, new models for crushing equipment were presented, one intended for static simulation and one time dynamic. Additionally, in Paper F a model of a storage unit was presented. The model development shares the same structure and fundamental ideas of modeling the internal process with a macro perspective. The outcome in both Paper A and B are two models that can predict machine performance for each machine, respectively. In Paper F the outcome is a model that can be used to predict the state and output of a storage unit over time in three dimensions.

6.1.1 Comminution equipment

In Paper A multiple scenarios of different settings were simulated with the developed jaw crusher model. As presented in Paper A, the model can handle different settings of CSS, eccentric throw, and eccentric speed. In Figure 6.1 the resulting internal variables from crushing a specific rock material are shown. This includes, a) the compression ratio for each compression, b) the position of a material package over time, c) the progression of the particle size distribution as the package of the material makes its way through the chamber. Finally, d) is the calculation of the bulk density in the crushing chamber. From the graph, it can be concluded that the material is compressed a certain number of times for a specific setting. How long the residence time is for the material package spends within the chamber, and how loaded the crusher is. If the bulk density goes above the inherent material solid

density $2600 - 2700\text{kg}/\text{m}^3$ ¹ then packing will occur, and the crusher will stop or stall.

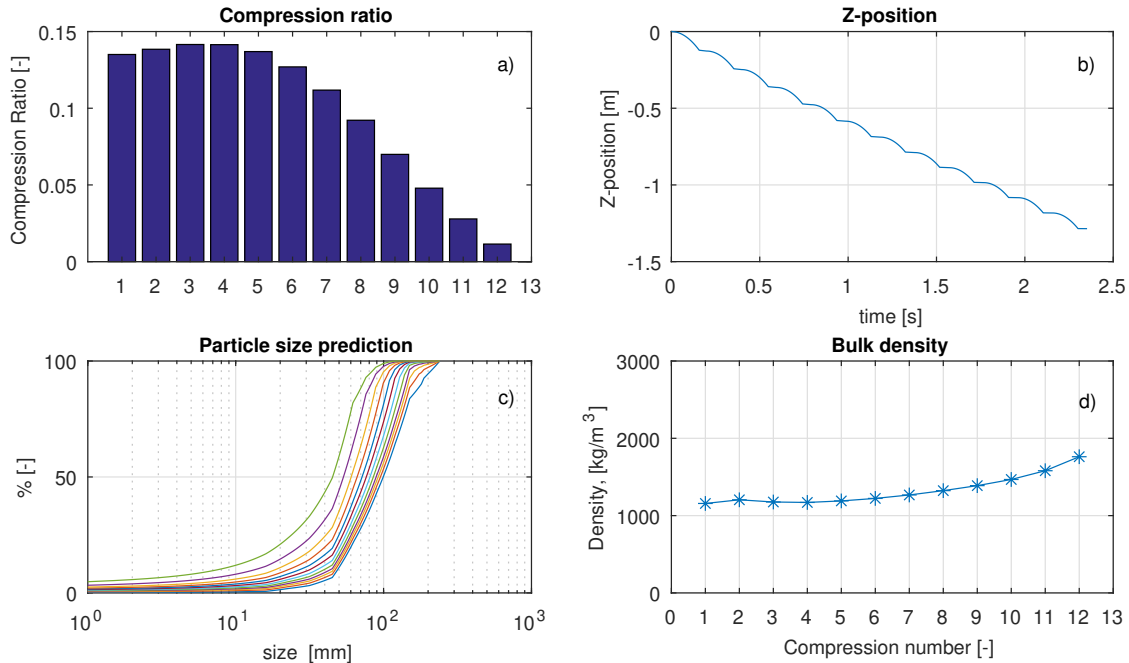

Figure 6.1: Model prediction for the behavior of the jaw crusher set at a 50mm CSS and operated at 300 rpm flywheel speed.

The jaw crusher model predicts power draw, capacity, and particle size. Validation data were available for the capacity and the particle size for the modeled crusher. However, the power draw has not been validated. The power draw calculated is only the power required to crush the rock and includes no losses. In Figure 6.2 a) the power draw is shown for different CSS settings and flywheel speeds, in Figure 6.2 b) the capacity prediction of the model is shown and compared against data from a manufacturer for the specific crusher size, and in Figure 6.3 the comparison of the particle size is shown for different CSS settings. The model response has been compared to available manufacturer data. However, more data for calibration and validation would be beneficial. When evaluating a model response, it is equally important to look at the response for a relative change and the actual value. For example, the PSD prediction in Figure 6.3 the response in the range 10 – 60 mm is off from the validation data, however comparing the results for $CSS = 100$ mm and $CSS = 80$ mm, the relative distance between the prediction and the validation data is close. This supports that the model replicates the phenomena that are being modeled, but it needs further tuning for better accuracy.

In Figure 6.2 (a), the prediction of the power draw is shown, and it peaks at around 300 rpm for all CSS settings. When the speed is increased the power draw decreases. The modeled power draw is the nominal power to crush the rock only, and with increasing speed, it is expected to find an increased power draw due

¹i.e. the solid density of $2600\text{-}2700\text{kg}/\text{m}^3$ for a granite rock material.

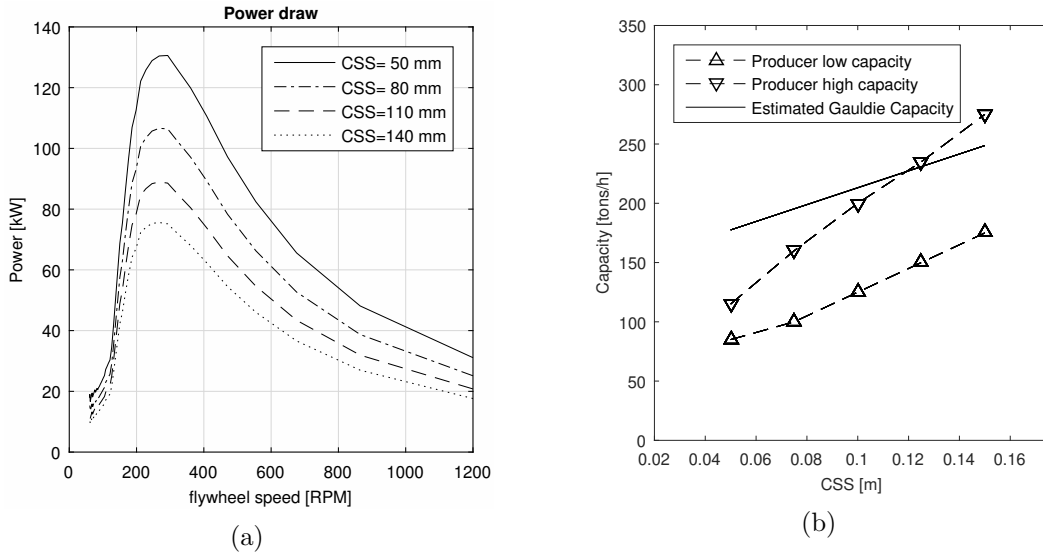

Figure 6.2: (a) Simulated nominal power draw for different CSS and different flywheel speeds. The power draw does not include any mechanical losses. (b) The simulated capacity of a jaw crusher compared to manufacturer data for a crusher of equal size.

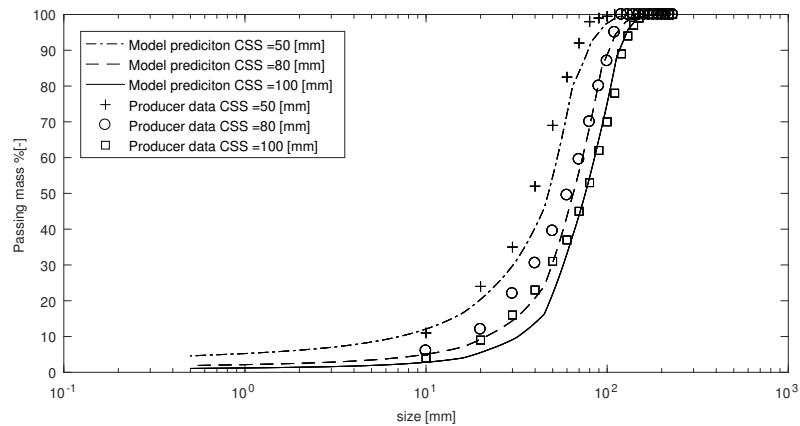

Figure 6.3: Simulated particle size predictions for three different CSS settings.

to the increased mechanical losses in drives, motors, and transmissions, and the bearings on the eccentric shaft. In Figure 6.2 (b) the capacity is predicted to increase with increasing CSS, which is expected. The manufacturer's lower values have a similar slope compared to the predicted capacity curve from the model. However, the prediction is far off in the lower end and within the high and low curves from manufacturer capacity values for large CSS values. This is an area of improvement for the model in future versions. In Figure 6.3 the particle size prediction for different CSS is plotted and compared against the manufacturer data. The correspondence is relatively good at the large sizes. However, it is slightly off in the finer end. In Paper A it was unknown what feed was used for the data that came from the producer, the fines in the feed will influence the prediction results. Apart from the difficulty in sampling the feed to a primary crusher, it would be a natural step to explore in the development of the next version of the model.

A dynamic HPGR model was presented in Paper B. In Figures 6.4, 6.5 and 6.6 are some of the outputs from the model presented. The model responds to changes in particle size, roller speed, and hydraulic pressure, which are the main inputs that can be changed. The model is parametric and can also be changed in terms of machine size, and the simulated machine parameters are presented in Paper B.

In Figure 6.4 the power and throughput have been simulated for different pressure settings and roller speeds. Even if it is a dynamic model, the model can be simulated to a steady value as there are no variations present in feed size distribution or from the controller and sensors for the results in Figure 6.4. The mapping is a good way to see how the model behaves over a wider range of operating conditions. The results in Figure 6.4 are inline with the simulations showed by Numbi [39].

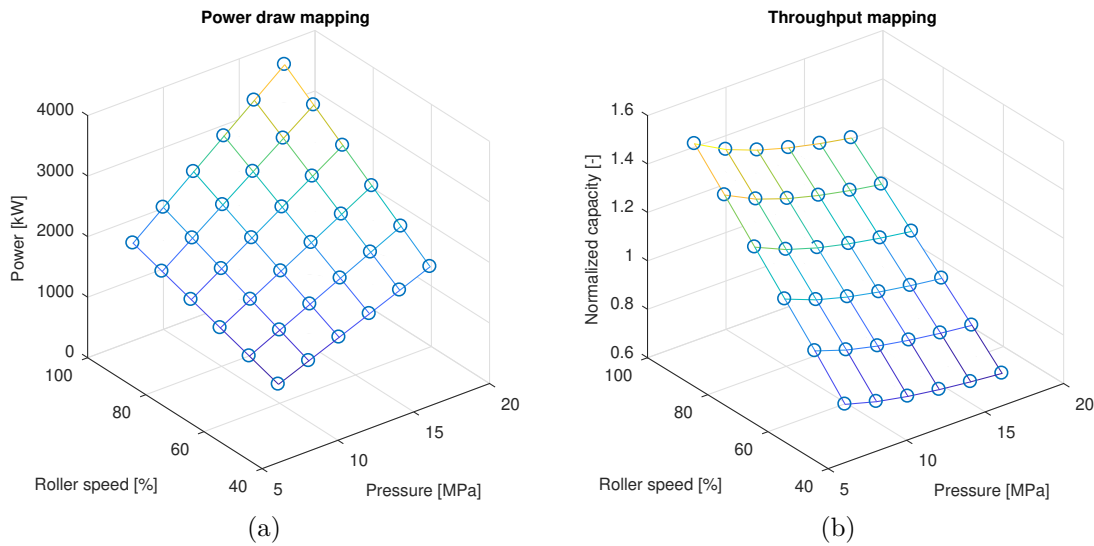

Figure 6.4: A Mapping of the performance for the HPGR model. (a) Power draw as a function of hydraulic pressure and roller speed. (b) Throughput as a function of hydraulic pressure and roller speed.

In Paper B, two data sets were used to validate the model, and as described above, these data sets were not used to tune to, just comparing the model prediction to what was seen in the plant. Validation set one is presented in Figure 6.5 and 6.6. In Figure 6.5 the time dynamic response of the model is plotted against the recorded data of the physical plant operating under the same conditions. The recorded performance numbers were capacity or throughput, nominal power draw, and the gap prediction. The bottom plot in Figure 6.5 show the input signals fed to the model; roller speed and hydraulic pressure. For the capacity prediction and the roller speed, there seems to be some sampling or logging error in the signal from the plant, the oscillations in the input may be due to a poorly tuned controller. However, the number of data points is sparse, which is unfortunate. The model's capacity prediction is about $\pm 5\%$ (normalized root mean squared error) over a 2800 second simulation. The predicted power draw follows the measurement, and most trends in the measurement can be seen in the prediction, which is a sign that the model picks up the effects which have the greatest impact on the power draw. For the gap prediction, the

results are acceptable, but in the beginning, at the time of $t = 350s$ there seems to be missing logic in the model that makes it behave differently from the physical plant. This should be worked on in an updated version of the model.

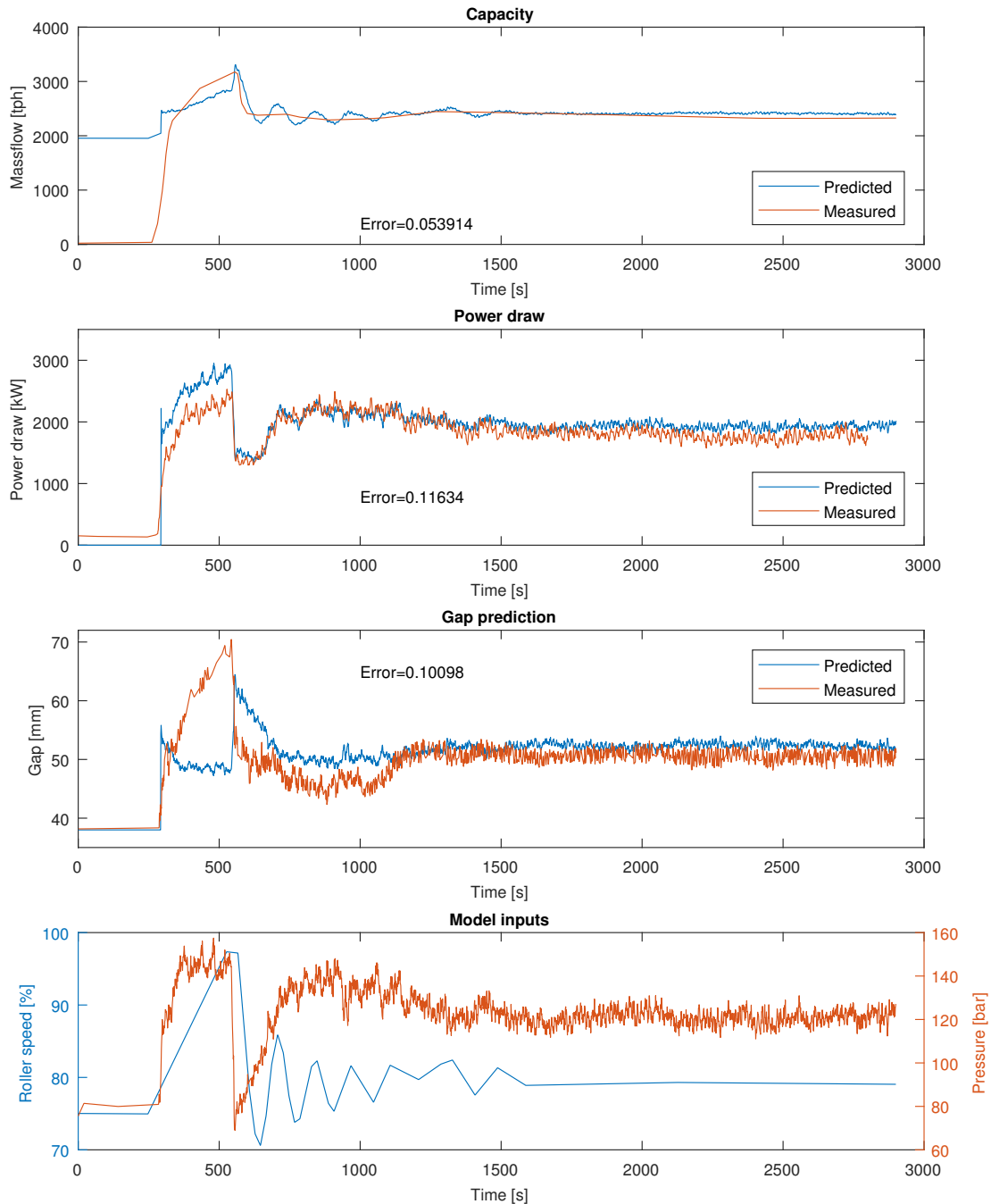

Figure 6.5: Model output predictions for the HPGR model for the survey conditions.

For the validation dataset on particle size distribution, only one sample was taken on the product belt after the HPGR. It was unclear when during the recorded data, the sample was obtained. Therefore the decision in Figure 6.6 was to look at the entire period the model predicted PSD and plot the finest and the coarsest

distributions. Figure 6.6 shows that the prediction of the particle size is capturing parts of the distribution, especially the top size and the fine end. The model was simulated with the same feed as the one the measured one from the survey. The shape of the distribution from the model is slightly more curved than the test data. If this discrepancy were further investigated in future studies, it would be recommended to utilize more test data and laboratory tests under the same conditions to understand what is happening.

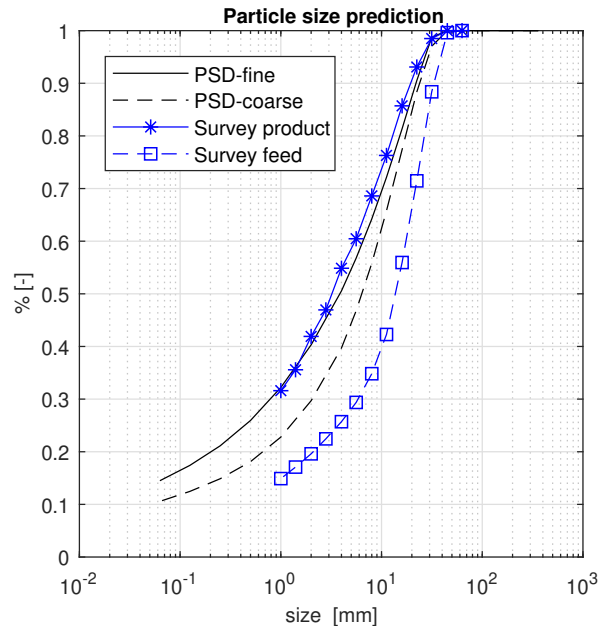

Figure 6.6: Comparison between simulated PSD predictions and the recorded PSD for the survey data used in the study.

The model presented in Paper B for the HPGR is a high fidelity model capable of predictions for a wide range of operating conditions. It can also handle different ore hardness and how this affects the performance, which was demonstrated in Paper B. The model shows good potential to optimize circuit performance and further strengthen the results in Paper E. The idea with the model is that it should correspond to changes in the operating parameters such that it can be used for control and operations investigations.

6.1.2 Storage unit modeling

In Paper F a model of a storage unit in 3D was presented. The model aimed to track the material level in the bin accurately. Additionally, to approach the problem of material tracking from a process point of view. In Figure 6.7 a series of images over a stockpile are shown. The simulation is based on the input and output signal plotted in Figure 6.8 (right). The model is initiated empty, the material is poured into the center for 1500 seconds and then withdrawn from underneath at the same rate. The height of the material bed in the center of the stockpile is plotted in Figure 6.8 (left). Initially, when the material is poured into the center, a cone is formed, and this cone

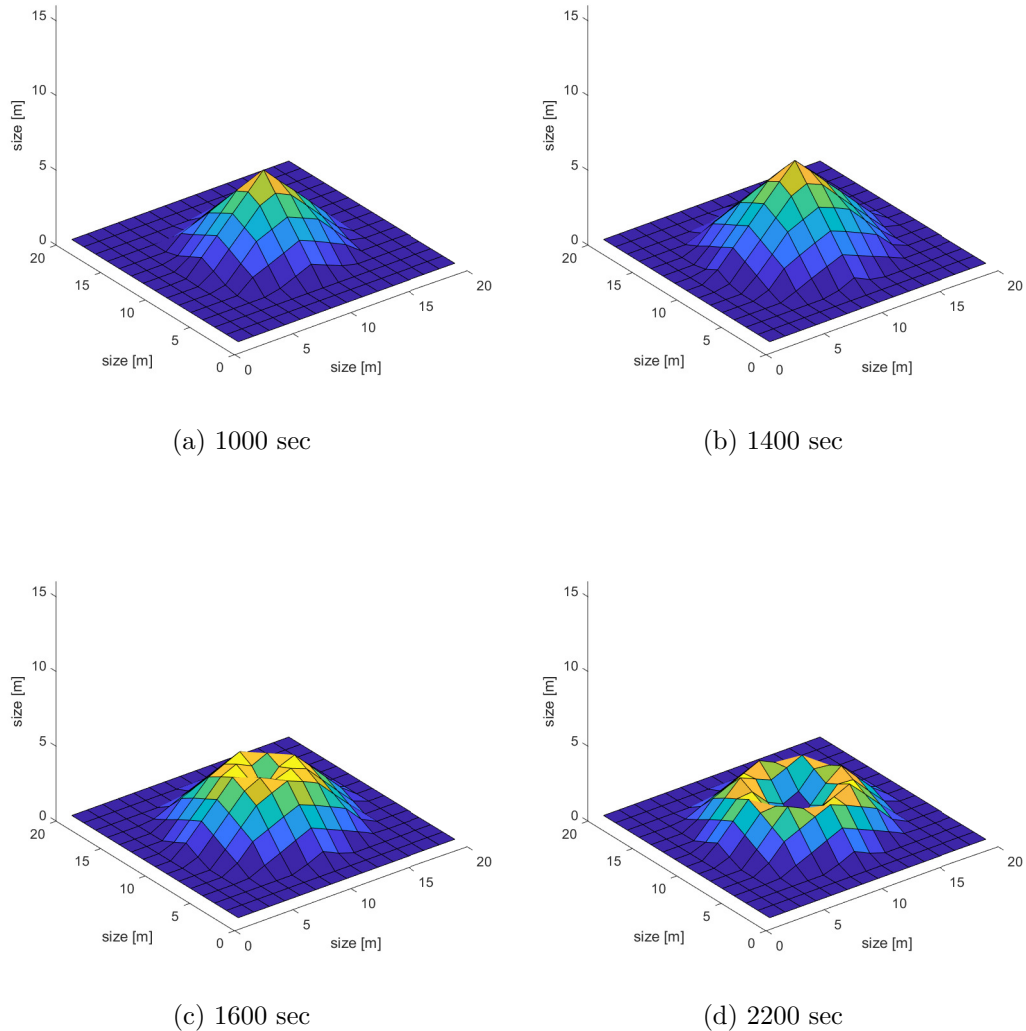

Figure 6.7: An image series of a stockpile's surface for an input and output sequence according to Figure 6.8 (Right).

grows. The amount of material needed to increase the height of the center of the stockpile grows exponentially. The exponential decay can be observed in Figure 6.8 (left) that the rate of change for the height is slowing down for a constant material inflow. At 1500 seconds, the inflow is halted, and an outflow of 1500tph is activated. The level decreases quickly and a crater is formed (See Figure 6.7 (c) and (d)). The crater grows, and eventually, the level is zero in the center, and no more material can be pulled out from that location. In Figure 6.8 (right), the flowrates are the desired rates, not the actual, as noted when the level is zero at right before 2000 seconds, the stockpile can not supply any more material, and the actual rate will be zero even if the desired amount is 1500tph.

To further test the model, two cases were presented in Paper F and one of them

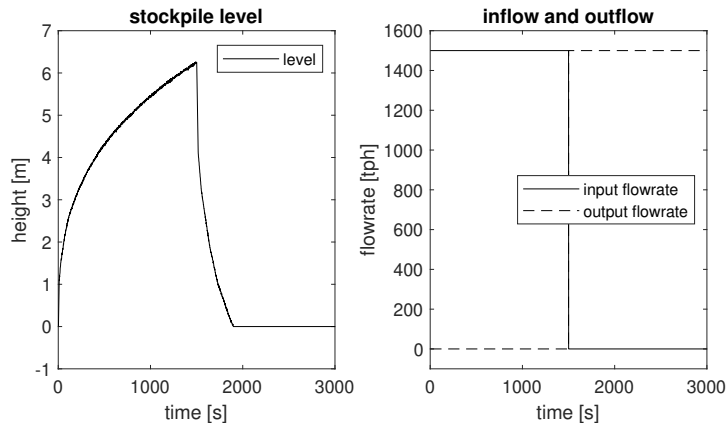

Figure 6.8: (Left) The material height in the center of the stockpile over time. (Right) The input and output flowrates for the stockpile simulation in Figure 6.7.

is plotted in Figure 6.9. It is a rectangular bin with one inflow, two outflows, and two level sensors. The geometry of the bin is described in Paper F. In Figure 6.9 (a), $S1$ and $S2$ are simulation results and $D1$ and $D2$ SCADA-data from the real

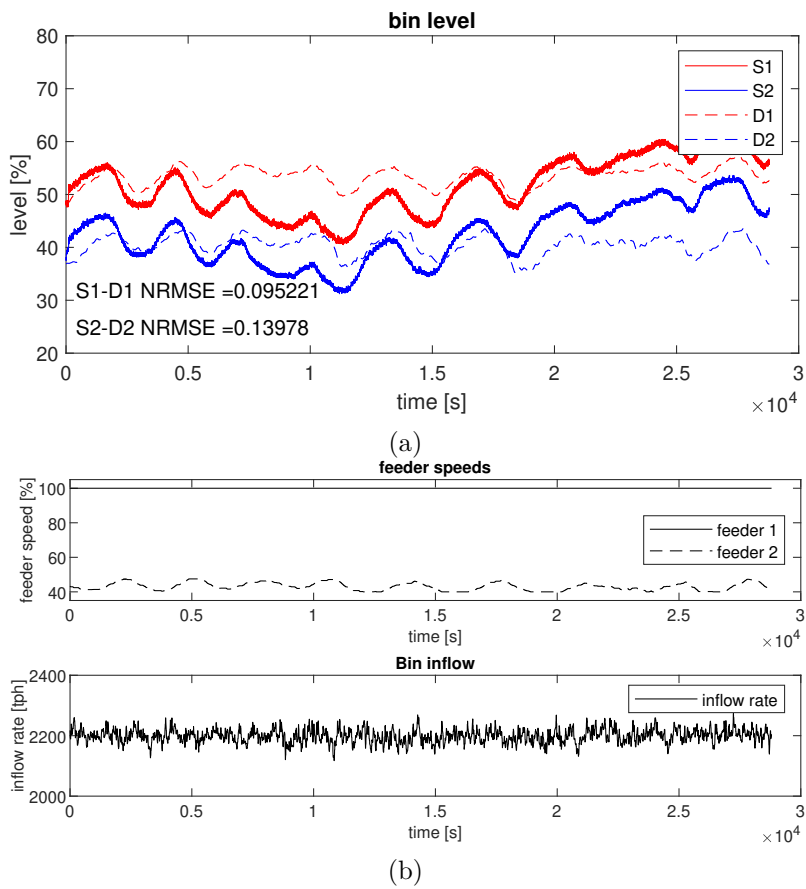

Figure 6.9: (a) The level readings from both simulation and measurement data for an eight hours simulation. (b) The input to the simulation in terms of feeder speeds and inflow of material.

plant's sensors. The presented simulation results are over a time of eight hours. Eight hours is a long time to simulate an integrator. The fact that the model prediction is dependent on initialization and previous errors makes the problem even more difficult. NRMSE values of 9,5% and 14,0% are not very exact; however, those values are more than acceptable for this type of problem. In Figure 6.9 (b) the feeder speeds and the inflow rates are plotted. Many of the changes in the level signal in Figure 6.9 (a) can be observed in both the recorded data and the simulation output, strengthening the model.

Regarding the model in Paper F, the material tracking has not been possible to test. However, some experiments in a lab or scaled environment would be needed to test the material tracking capability. The model keeps track of particle size and properties in each of the zones within the model, and mixing is implemented as perfect mixing in each zone.

6.2 Process control

In this section, the results from Paper C are presented. The paper is mainly focused on process control. In Figure 6.10 and 6.11 two different objectives of the controller were simulated for an eight hour period. The objective was in both cases to keep the bin levels to 50%, and for Figure 6.10, the controller was free to produce as much as possible on the final product belt. For the case in Figure 6.11 the controller should instead keep the product belt tonnage to a specific rate. As the control problem is functionally controllable, the controller could settle into these setpoints for both the cases with and without a setpoint on the circuit production. For the maximized production, the controller reaches the constraints of the feeders in the circuit model.

In Figure 6.10, the objective is set to maximize the outflow from the circuit; therefore, the controller drives the HPGR throughput to the feeders' limit. The green and the red lines in the top graph of Figure 6.10 are the throughputs of the HPGR, and the screening throughput since all the material that comes from the HPGR has to be screened. These two should end up at the same level when a steady-state is reached. The inflow and the outflow also have to match once a steady-state is reached. This can be seen as the black, and the blue lines settle into the same level. The two bin levels plotted in the lower graph of Figure 6.10 also settle into their setpoint at 50% after a few hours, the settling time of these levels depends heavily on the prioritizing between the objectives in the controller and the tuning of the local PI-controllers. When it comes to comminution circuit designs, bins and silos are there as buffers, and one of their functions is to absorb the fluctuations within the circuit. As long as the levels are kept within the safe operating conditions, neither risking that the storage unit will run empty or overflowing, the level should be allowed to vary.

For the second case, plotted in Figure 6.11, a setpoint is active on the circuit output, which is shown in the top graph of Figure 6.11 as the dashed black line.

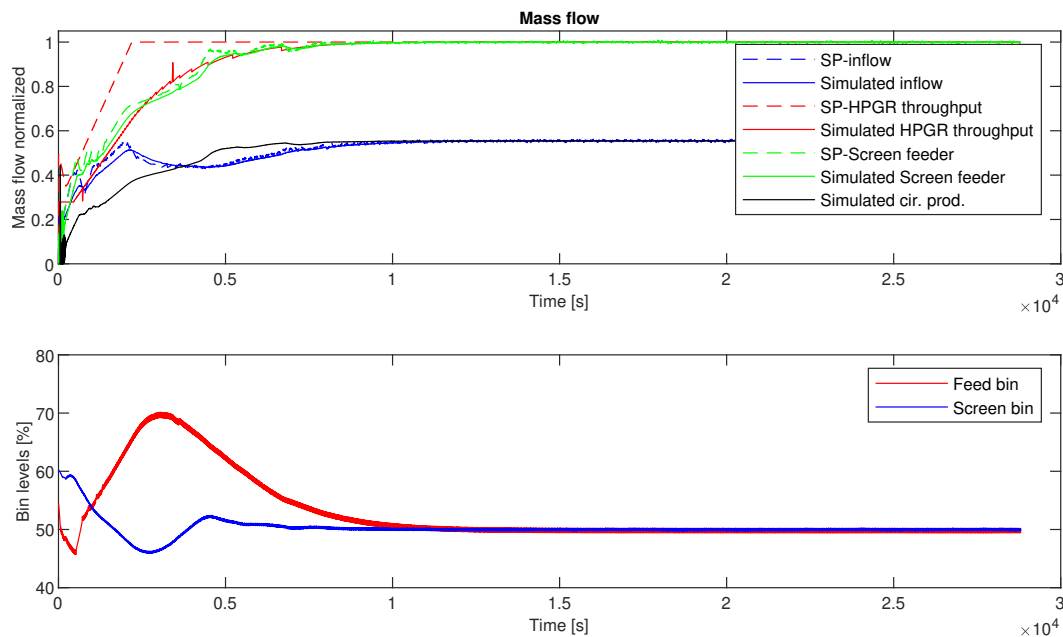

Figure 6.10: Simulation results for a controller which maximizes the output of the circuit (Simulated cir. production)

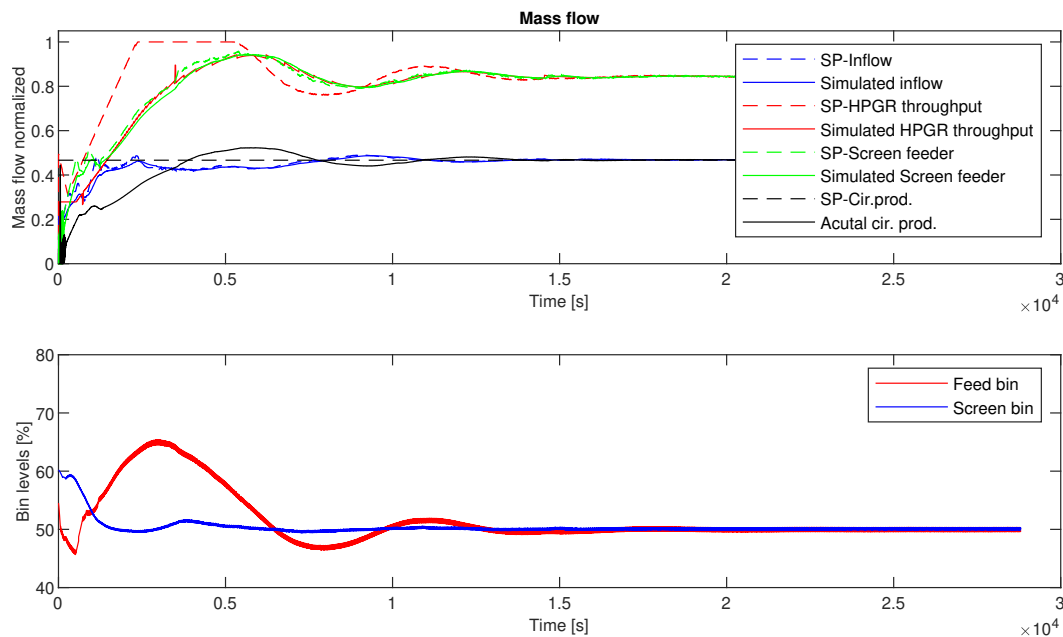

Figure 6.11: Simulation results for a controller with three objectives, bin level control and production rate control.

In this case, the red and the green lines will settle into a slightly lower level as the setpoint for the circuit production is set lower than the maximum rate of the feeders. For the bin levels in the bottom graph, the feed bin in red has a slightly smaller overshoot than in Figure 6.10. When comparing the two simulated cases, the second case is preferred, as when the maximization reaches the constraints of other parts in the circuit, it will be limited in its range of how it can move, as it

will only be able to slow down. It is preferred to set an actual setpoint that the controller should hold. However, for debottlenecking and plant optimization in the simulation environment, it is a practical approach as there is minimal risk associated with running the simulation.

Another aspect that is present in both Figure 6.10 and 6.11 is when the controller is set up in a "setpoint slaving" fashion as described in Section 5.3, the MPC will calculate setpoints and send to the local SISO-loops. If the control loops are very slow, which is the case with the HPGR throughput setpoint, it can be observed that the solid red line is below the red dashed line. The dashed line is the value that is being calculated by the MPC, and the solid line is the output of the SISO-loop. If this distance or lag between these two is too large, the controller can become ineffective and possibly unstable. The SISO-loops have not been retuned for the study in Paper C. However, if the circuit was controlled with an MPC on a daily basis, the loop speed (controller gains) could probably be increased, and this effect minimized.

6.3 Circuit modeling

Circuit modeling has had two different focuses within this thesis. First in terms of robustness of crushing circuit and stages, presented in Paper D and Paper G and covered in Section 6.3.1. Second on a higher fidelity level in Paper E and Paper H, which is covered in Section 6.3.2.

6.3.1 Robustness simulations

From Paper D, the robustness properties, and the controllability were explored for the circuit presented in Figure 5.6, which was presented in Section 5.2.1. Firstly in Figure 6.12 and 6.13, the time response is shown for when there are no introduced variations and for 5% periodic variation of the crusher capacity and split ratio over the screen. In Figure 6.12 there are a few on/off events because of the interlocks and some initial oscillation. However, after that, the circuit moves to a steady-state in all variables. This is because the circuit capacities are balanced (the production rate of sub-circuit 1 is exactly equal to sub-circuit 2). When variations are introduced as in Figure 6.13, the response is not in steady-state anymore, and an erratic interference pattern appears, especially for the flows, as the interlocks turn these on and off. It can be concluded that a balanced circuit could be stable if there are no variations present. However, as soon as there are variations, there is a chance of ending up in an interference pattern as in Figure 6.13. The exact pattern and effect are dependent on the phase of the variations as well. In Figure 6.14 the circuit in Figure 5.6 is simulated without any variations. For Figure 6.14, the circuit is unbalanced in the sense that the crusher's capacity in sub-circuit one is different from the crusher's capacity in sub-circuit two. The conclusion from Figure 6.14 is that as long as the downstream circuit is the bottleneck, the loss in production rate is minimal. However,

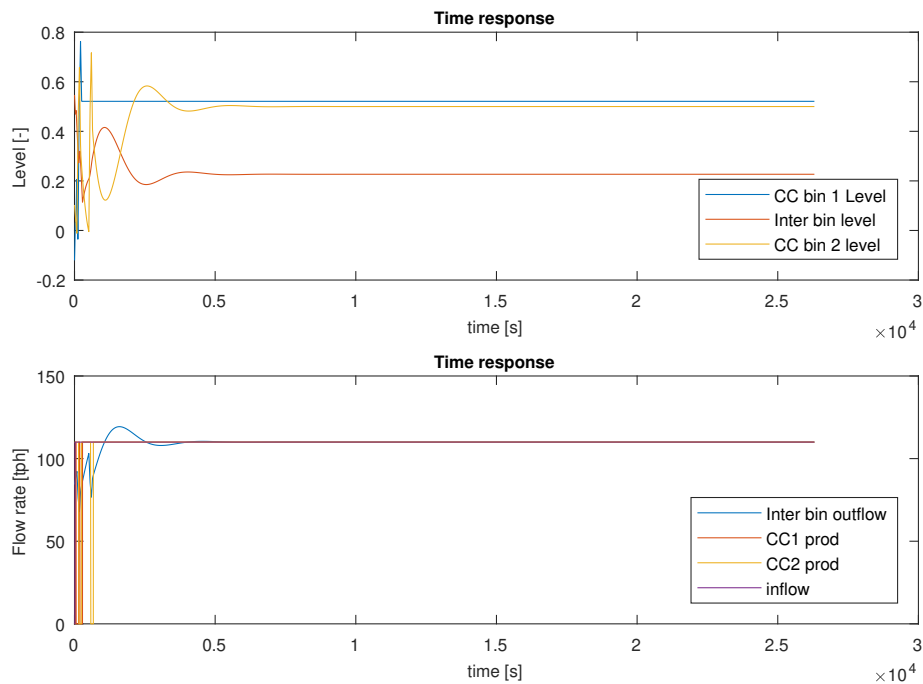

Figure 6.12: Simulation of the flowsheet in Figure 5.6 (a) with no introduced variations.

if there is undercapacity in the upstream and overcapacity downstream, the circuit can lose up to 30% of its performance for the simulated case.

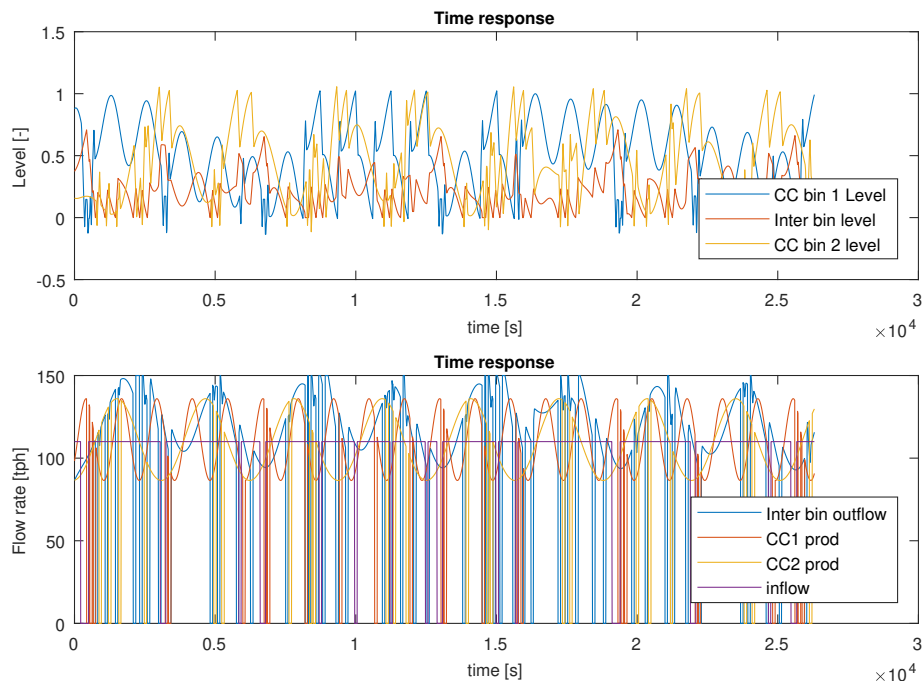

Figure 6.13: Crusher capacity and screening split varied with 5%

If variations are introduced for the crusher capacity and screening split, the results in Figure 6.15 are obtained. Figure 6.15 (a) and (b) are simulations of how

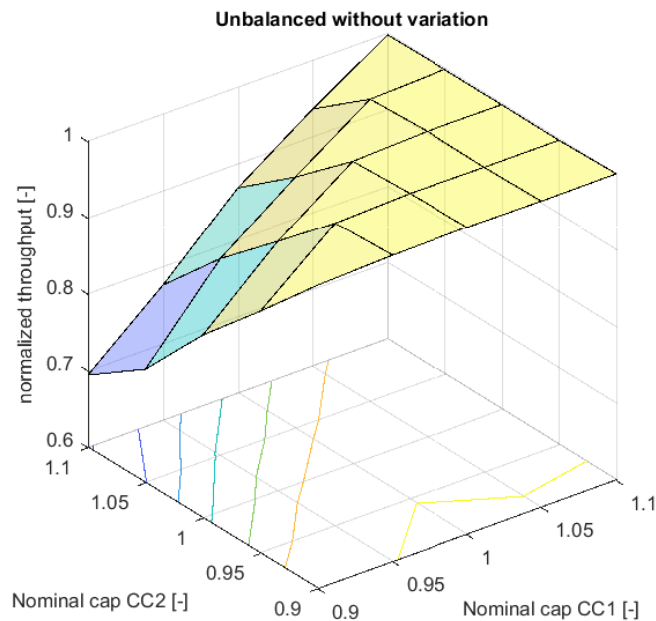

Figure 6.14: Simulation results from the circuit without variations and shifting the balance between the two crushing stages to see the overall circuit throughput effect.

the throughput is affected by the different bin sizes. The difference between (a) and (b) is the type of variations that is present, in (a) it is a white noise and in (b) the variation is periodic. The purple, blue and yellow surfaces correspond to different initial bin levels. In Figure 6.15 (b), the performance starts to decrease at an intermediate bin capacity lower than 10 tons, which is visible by looking at the contour lines. However, for Figure 6.15 (a) this happens at about 7 tons. The conclusion is that the periodic variation has a more severe effect on the performance. For the bin before the crushers in each sub-circuit, the difference between (a) and (b) seems to be very small. These phenomena will need further investigation to make the conclusions more rigid and extend their validity, and some of these questions have been approached in Paper G.

Finally, in Paper D, the "push" strategy was evaluated, in other words trying to push in as much material as possible into the circuit. The results of this are shown in Figure 6.16. The available feed to the circuit from Paper D is varied between from 60% to 140%, and the circuit throughput is recorded for 8 hours. If the circuit is underfed, it performs poorly as it goes on and off, clearly showing that the interlock strategy is not sufficient. As the input is increased, the performance gets better and better, and between 90-100%, the input is nearly the same as the throughput. If the input is increased further due to operating the crusher choke fed, it does not benefit from increasing the input as the crusher is limited in throughput regardless. The lower input ranges can be handled sufficiently by implementing a better control strategy, as shown by Asbjörnsson [1]. However, it is not possible to push material through a cone crusher circuit. The only way to get more throughput is to increase the

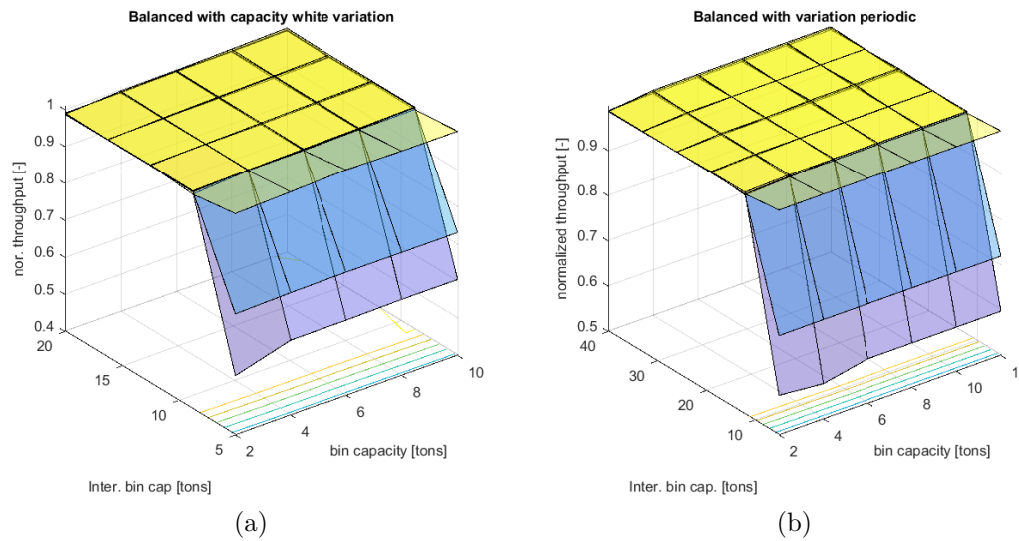

Figure 6.15: Simulation results for the throughput with different bin sizes when variations are present, in (a) the variations are white noise, and in (b) the variations are periodic. In both cases, each sub-circuit has a balanced nominal capacity.

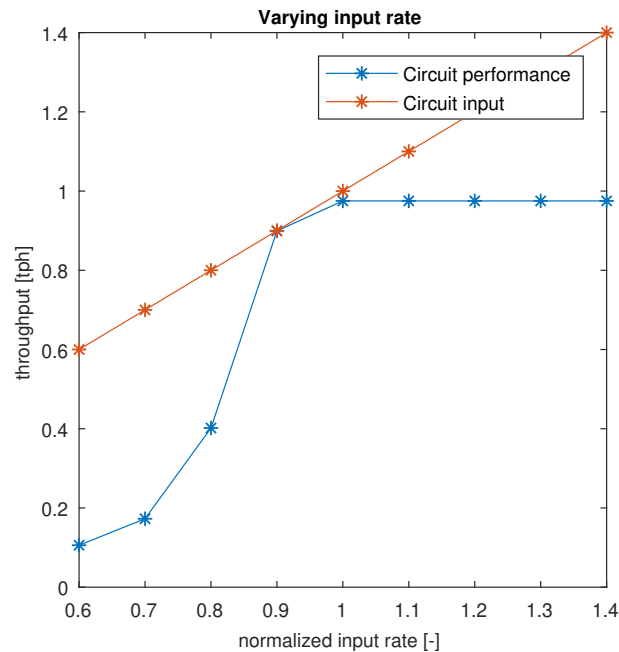

Figure 6.16: The relationship between the circuit input rate and the circuit performance for the investigated circuit from Paper D. Below 0.9 in input rate, there is an interlocking effect, and above one, the circuit is crusher limited.

crusher's capacity. In conclusion, from Paper D, an adequately designed plant should have equally many manipulated variables as controlled variables. They should be robustly designed, in other words, be able to handle variations of different types that may appear in operations. This is closely related to having adequately implemented control and measurements such that the plant can be steered to and around the desired operating state.

In Paper G a more formalized approach was taken compared to Paper D and with a slightly narrower scope, focusing on only one crushing stage. A linear system in the Laplace domain was formulated for the circuit, and robust control was applied to study the closed-loop crushing stage's stability margins and performance margins. The flowsheet and block diagram was presented in Figure 5.7

In Paper G a single crushing stage unit was studied in terms of its stability and performance margins. The crushing stage was approximated by the block diagram in Figure 5.7. In Figure 6.17 (a), the Bode responses for the system from input to output are shown, and in (b) simulation of step responses. The system was defined as an uncertain system, and this is represented in Figure 6.17 with the dashed red line as the nominal response and the blue lines as a subset of the uncertain responses. Figure 6.17 (a) shows that there are no major gain peaks in any of the outputs. There are some ripples from $m1$ to $y1$, which is due to the re-circulation feedback. In Figure 6.17 (b) the resulting step responses show slow responses and some overshoot. The system is very slow due to the large bins and delay times. However, all responses, including the uncertain ones, appear stable and well behaved.

In Figure 6.18 the stability and performance margins are plotted for different time delays. For delay, d_1 and d_2 , the margins decrease as the delays are increased, while the stability and performance margin is not affected by the change in delay time for the re-circulation. The actual numbers are case depended on the setup in Paper G. The slope and position of the curves will change if controller type or settings are changed.

In Paper G, the nominal values of the crushing stage's design parameters were varied to see their effect on the stability and performance margin on the overall crushing stage. In Table 6.1 the numerical results are presented for the full block diagram in Figure 5.7. The arrows in the column of relative stability and relative performance margin indicate in which direction the stability and performance moved the change of the parameter. In terms of stability, the most critical part is the hopper loop, and only changes that affect the hopper loop will change the actual stability margin. The performance margin is close to the same result, except that a change in bin size will affect the performance margin. The actual numerical values in Table 6.1 are in relation to the setup in Paper G however, the direction of the trends are extendable to other circuits of similar size and type.

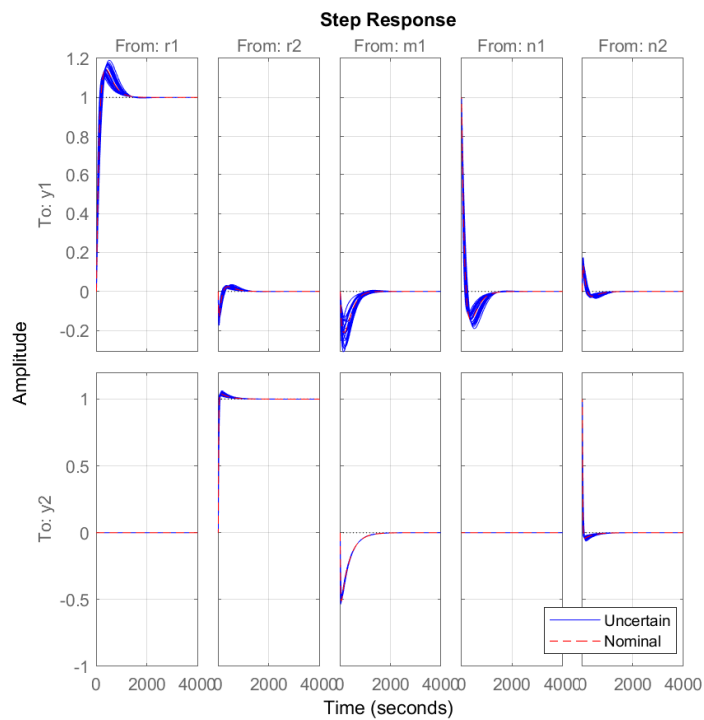
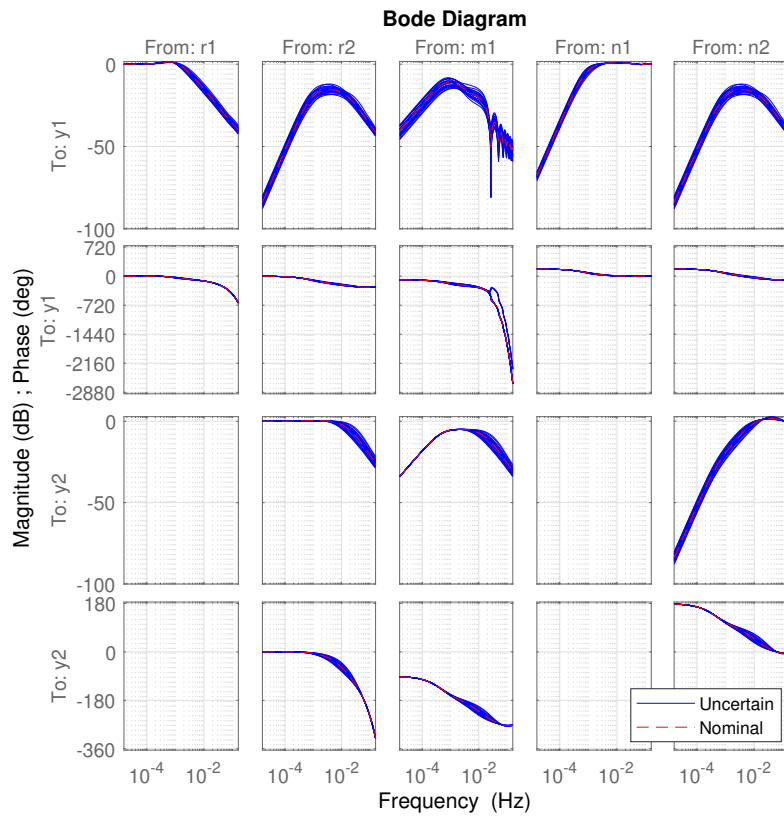

Figure 6.17: Bode diagram (a) and step responses (b) for the full system of the block diagram in Figure 5.7. The red dashed line is the nominal system, and the blue lines are a subset of the combinations of the uncertainty set.

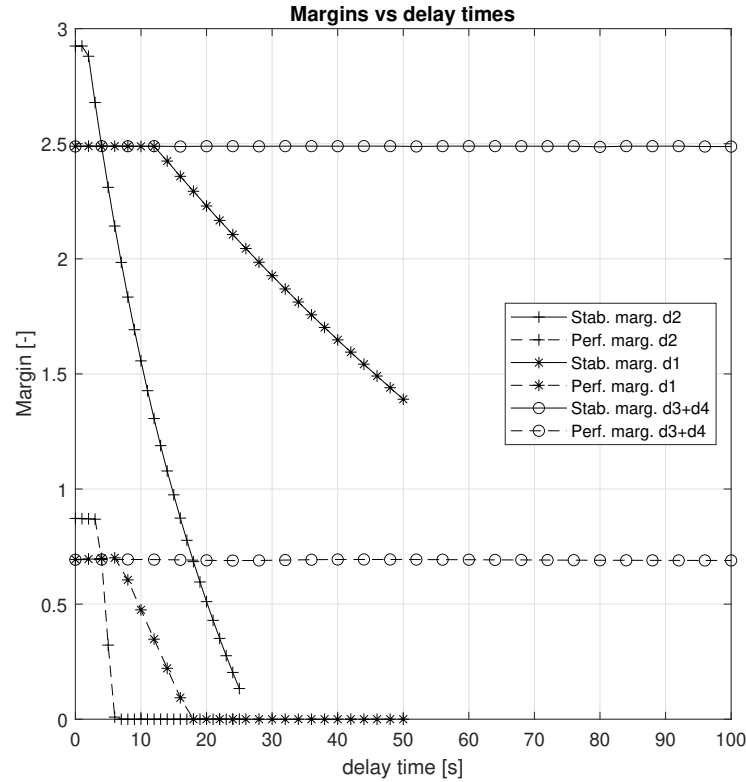

Figure 6.18: Stability and performance margin when changing the time delays, d_1 , d_2 , and $d_3 + d_4$. All other parameters have been kept to their nominal values from Paper G

Table 6.1: The resulting changes in stability and performance margin for changes of the parameters of the full system with both loops connected with re-circulation. The arrows in the relative stability and performance margin columns indicate the direction of change for the margin.

Parameter change	Stab. Marg.	Rel. Stab marg.	Crit. Freq. [Hz]	Perf. Marg.	Rel. Perf marg.	Crit. Freq. [Hz]
Nominal	2.49	1.00	0.0622	0.69	1.00	0.0308
$k_{bin} +20\%$	2.49	1.00 \rightarrow	0.0622	0.68	0.98 \searrow	0.0007
$k_{bin} -20\%$	2.49	1.00 \rightarrow	0.0622	0.67	0.97 \searrow	0.0290
$k_{hopper} +20\%$	2.61	1.05 \nearrow	0.0622	0.80	1.15 \nearrow	0.0007
$k_{hopper} -20\%$	2.31	0.93 \searrow	0.0622	0.34	0.50 \searrow	0.0310
$k_{u1} +20\%$	2.35	0.94 \searrow	0.0622	0.40	0.58 \searrow	0.0303
$k_{u1} -20\%$	2.64	1.06 \nearrow	0.0622	0.58	0.83 \searrow	0.0007
$k_{split} +20\%$	2.49	1.00 \rightarrow	0.0622	0.69	1.00 \rightarrow	0.0306
$k_{split} -20\%$	2.49	1.00 \rightarrow	0.0622	0.69	1.00 \rightarrow	0.0295
$d_1 +20\%$	2.49	1.00 \rightarrow	0.0622	0.70	1.00 \rightarrow	0.0298
$d_1 -20\%$	2.49	1.00 \rightarrow	0.0622	0.69	1.00 \rightarrow	0.0309
$d_2 +20\%$	2.35	0.94 \searrow	0.0518	0.39	0.56 \searrow	0.0249
$d_2 -20\%$	2.64	1.06 \nearrow	0.0778	0.87	1.25 \nearrow	0.0007
$d_3 + d_4 +20\%$	2.49	1.00 \rightarrow	0.0622	0.69	1.00 \rightarrow	0.0308
$d_3 + d_4 -20\%$	2.49	1.00 \rightarrow	0.0622	0.69	1.00 \rightarrow	0.0295

6.3.2 Circuit simulations and calibrations

From Paper E and by Johansson [26], evaluations between model accuracy and plant data have been made for larger circuit models intended to be used for simulations and predictions of circuit performance. The error between the plant data and the model prediction was calculated and aimed to be as low as possible. In Paper E it is shown that an entire circuit can be described with an average error below 10%. To be able to trust the dynamic process models that are being developed, this is a tool to show how well the model describes reality. In Figure 6.19 an example of a signal logged in a SCADA-system plotted together with a model prediction from a dynamic model running with the same inputs as the real plant had for the same time period. Indications that the model describes the actual process can be identified in the graph if the patterns of the lines are similar, not only looking at the value but also if the plant and the model are moving in the same direction. For the example in Figure 6.19, the prediction follows many of the trends seen in the process data, however not all of the trends. Especially for the start and stop sequences, the model deviates more extensively from the real process. The deviation can be explained by the model that has been developed to describe normal operating conditions. The model does not include all events involved in start and stop sequences.

In Paper H a framework for a more methodical and automated calibration process was tested. Figure 6.20 shows a response surface from evaluating a simplified model of the feeder system in Figure 5.9 relative to the measured SCADA-data. The height of the response surface is the NRMSE values for each of the parameter combinations. Apart from showing the parameter combination, which leads to the lowest error, the surface also gives a hint about the problem structure.

The response shown in Figure 6.21 is the measurements, the simplified model response, and the full model response. As desired, the full model is more accurate as the NRMSE is 0.069 for the full model and 0.079 for the simplified model. The simplified model's response lies on top of the full model response most of the time. However, the saturation of the response is active in a few places.

The results from Paper H will be helpful when setting up larger calibration schemes and tuning models on a more regular basis. The effective way of dealing with the dimensionality and the section of the circuit results in a problem that can be solved without being as daunting as manually tuning a full circuit model as described in Paper E.

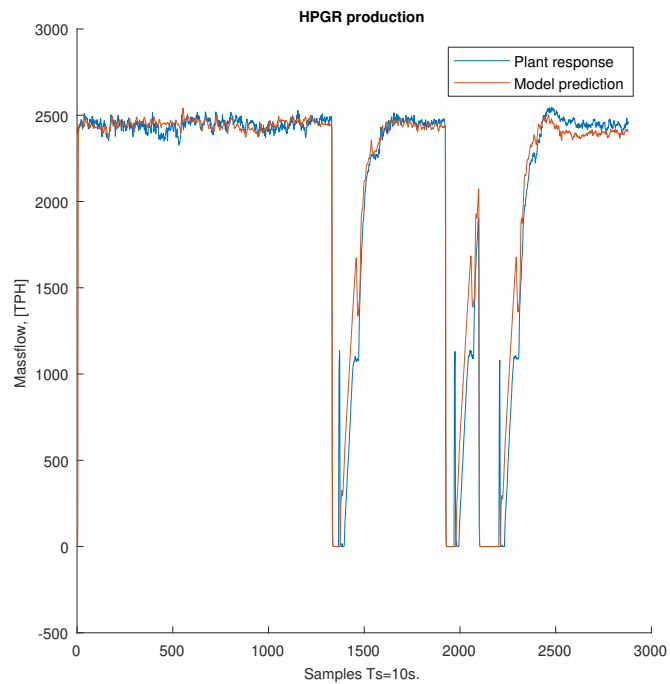

Figure 6.19: Model predictions plotted with actual plant data from Paper E as a way to quantify how well the model captures the plant behaviour.

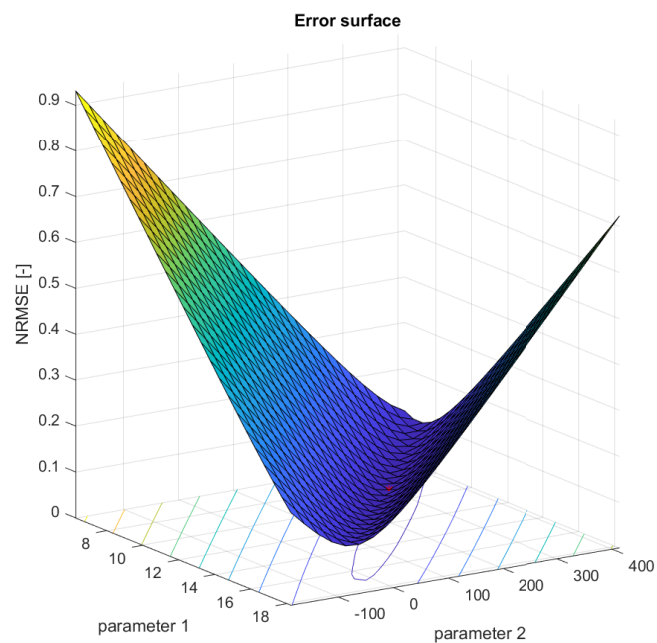

Figure 6.20: The response surface for a set of parameter combinations, the red star, is the parameter combination yielding the lowest error.

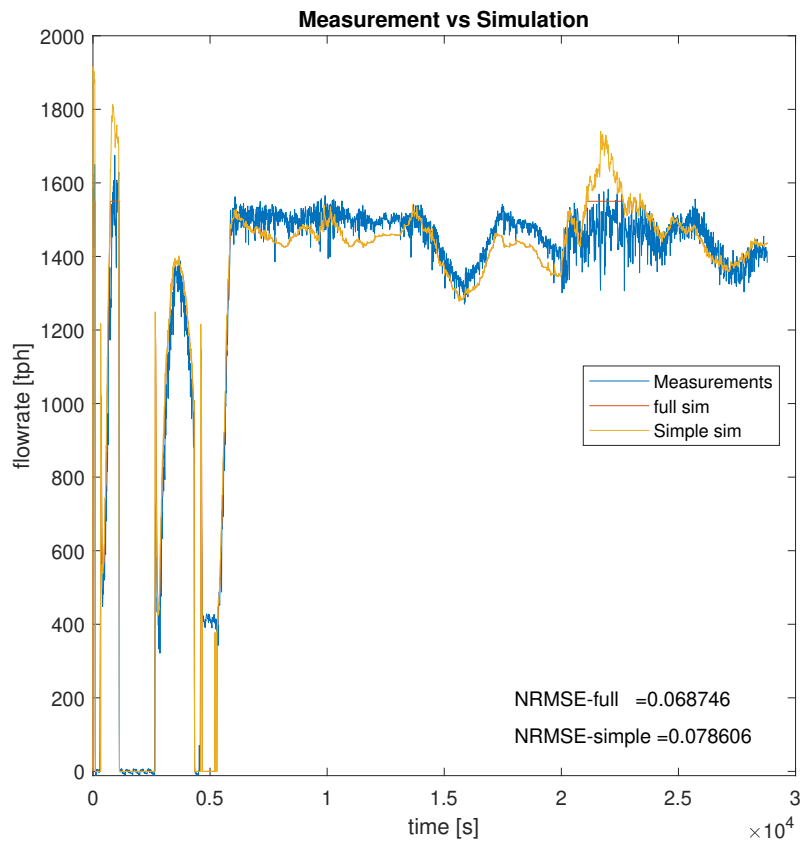

Figure 6.21: Model responses from a simplified model and a complete model compared to the measurements.

Chapter 7

Discussion

In this chapter, the results and outcomes of the research are discussed along with the answers to the research questions. Finally directions for future work within this research are given

The research presented in this thesis is focused on modeling and understanding of how to model and how to apply the models in different scenarios. The three main areas of dynamic modeling that are touched upon and where the front line of the research is pushed forward with this thesis include:

- High fidelity models
- Fast process models
- Control models

The models are all designed to be time dynamic and have predictive capability. The minerals processing and aggregates industry have long relied on steady-state models for plant design. When the margin of profit is getting smaller, minerals processing operators are looking for opportunities to improve their processes, where an integral part will be the comminution and classification plants. To fully understand and improve operations, tools such as time dynamic modeling will be needed. The way this type of research will move forward is by problem oriented challenges and by developing solutions for specific problems. Apart from the need for new models and implementation, there will also be a need for the skills to simulate and interpret the results from time dynamic simulations. The amount of generated data is far larger than from a steady-state simulation, which will require the ability to process the data and extract valuable information from it. Additionally, time dynamic modeling should have a bigger input to when plants are designed, mainly to analyze robustness and that the modes of operation planned for the plant is within its range. Control and control strategy will be more important as the industry is moving towards more automation and less human interaction for control of the plant. As highlighted in this thesis, time dynamic models are a suitable tool for testing and developing control and automation solutions.

Physical modeling will always be an alternative to data-driven models in the future. If the model structure needed to describe a particular unit is not possible to implement in the controller, one may need to resort to a linearized model with updated coefficients depending on the operating point. Data-driven modeling will impact the world we live in, as the quantities of data collected grow day by day. This will be the case in minerals processing as well, with most certainty. However, it is essential to pay attention to assumptions made and not blindly trust all models and the data. All models come with inaccuracies and process knowledge will still be required in order for successful implementation and qualitative understanding.

The idea behind Paper D and Paper G was to approach the operations problem from the opposite side to traditional high fidelity circuit modeling. The method researchers usually apply in minerals processing includes utilizing a rigorous testing program of ore responses and sampling and then back fitting a static model to a single data set. The reasoning in Paper D was the right opposite, namely to use as little information and testing as possible. Instead the research idea was to estimate the variations and introduce them in a simulation model that decently describes the circuit or process. From thereon utilize the computer ability to simulate a range of variations to understand what the output space looks like. The method demonstrated in Paper D was an inspiration and a starting point for Paper G where a frequency approach instead was used combined with available control theory to more rigorously explore the problem. The frequency approach may be harder to grasp. However it is closer to being possible to extract rules and knowledge from it compared to the exhaustive simulation method. The combined insight from the two approaches should be formalized and used in the design and analysis of processing plants, potentially with the impact of avoiding poorly designed plant layouts.

In Table 7.1 current developed unit models and their application levels are tabulated. As mentioned previously different models have different areas of applications and it is important to distinguish between them and how they can be used.

Table 7.1: Summary of models on different application levels

Model	High fidelity	Fast	Control model
HPGR	x	x	x
Jaw crusher	x		
Conveyor		x	x
Screen		x	x
Bin/storage unit	x	x	x
Cone crusher		x	x

Future work will aim to improve the model library and to include more equipment models on all levels.

7.1 Answers to the research questions

In Figure 7.1 a mapping is shown of how the different papers relate to each of the research questions. A smaller dot refers to background knowledge, and a bigger dot substantial contribution to the answer. After that, the research questions are answered.

Papers	Jaw crusher model	HPGR model	MPC	Robust process analysis	HPGR circuit modeling	Storage model	Robust plant design	Calibration method
	A	B	C	D	E	F	G	H
R.Q. 1	●	●			●			
R.Q. 2		●				●		
R.Q. 3						●		
R.Q. 4					●			●
R.Q. 5				●			●	
R.Q. 6				●			●	
R.Q. 7			●	●	●		●	
R.Q. 8	●	●	●	●	●	●	●	●

Figure 7.1: A graphical outline on which of the papers have contributed the different research questions.

R.Q. 1: How can high fidelity fundamental models of minerals processing equipment be developed in order to handle machinery of force-conditioned type?

Answer: In a crushing machine such as the HPGR, the hydraulic pressure dictates how much the material bed is compressed and ultimately reduced in size. To model the size reduction, it is of interest to know the compression ratio for a particular hydraulic pressure. In Paper B, the force from the hydraulic system is used to solve the equation of motion for the roller. The equation of motion is an ordinary differential equation and can be solved by finding its explicit solution in state-space form. Having calculated the position of the roller, the force-conditioned machine has been translated to a compressive device. The position of the roller can be used to calculate the compression ratio the material is exposed to. The compression ratio and the minimum gap are the inputs to the size prediction method developed by Evertsson [15], which are needed to calculate the product particle size distribution from a compression event. The approach used in Paper B can

potentially be extended to other equipment, which can be classified as force conditioned. One example of this can be modeling of a hydrocone style cone crusher. This could potentially be used to resolve the relationship between the actual mantle position in relation to the hydraulic piston. To succeed in developing these models, it is essential to reflect on what data is available and can be captured for calibration and validation of the model outputs. If the intention is to develop a dynamic model, there should be time varying data available to verify and tune the model.

R.Q. 2: How can fundamental models of minerals processing equipment be developed in order to handle machinery with fast dynamic behavior?

Answer: In both Paper A and B, the residence time in the crusher is short, and the way to handle this has been to locally within the model increase the sampling frequency and do multiple calculations per iteration. In Paper A, it is resolved to describe a material packet as it passes through the crusher. In Paper B, the equation for solving for the capacity and position of the roller is discretized at 400 Hz, for each iteration of the model, the position of the roller and the forces are solved for 400 times. The choice of the frequency is based on the speed of the rollers and to have a high enough number of crushing zones for all roller speeds.

R.Q. 3: How can material storage units be modeled in a process simulation environment?

Answer: In Paper F a flexible storage unit model was presented. The modeling builds on the idea of approximation by small elements and the physical behavior of rock piles with repose angles. The implemented matrix version of the model is possible to use in a process simulation environment and simulate faster than real-time. The approach has also been proven to correspond well to data of level readings in real storage units. In Paper F the behavior of the material bed within the storage unit is also discretized, and by using many calculation events, the behavior can be modeled. In the case of Paper F the transfer of material is a process that checks all cells and for every cell its neighboring cells. This results in transferring a small amount of material for each transfer but with many transfer operations. The model framework is flexible and can be applied to all material storage units which follow the type of boundary conditions allowed. The model is developed without any iterative calculations that need to converge.

R.Q. 4: How can process models of circuits and plants be calibrated efficiently?

Answer: Calibration is an important task in the successful deployment of dynamic simulation models. The method in Paper E is was to do the plant calibration manually, which is not a practical way forward. In Paper H, a method is introduced to split the circuit in different nodes and simplify the models as much as possible to focus on the tuning of the most influential parameters in the model. If all parameters are attempted to be calibrated

at once, the problem quickly grows and becomes infeasible to compute and carry out in an automated way. Additionally, in relation to validation when doing calibration of plant models, it is important to validate on the newly calibrated parameters on never before seen dataset, as described in Section 2.2.

R.Q. 5: How can a minerals processing plant's degree of robustness be studied and quantified?

Answer: A minerals processing plant processes natural material, such as rock, which comes with natural variations that affect the process. In Paper D, fast models and control logic was used to study a circuit's sensitivity to variations and how variations and materials storage unit sizes affect the ability to cope with variations. The approach was to use a large simulation test plan, which was possible as the simulation models used were very fast. In Paper G a narrower focus was taken on a single stage of crushing to quantify how robust a specific combination of parameters is. This resulted in stability and performance margins that can be calculated to measure how robust a specific design is. Paper D is similar to a Monte Carlo approach to the problem. However, for a time dynamic simulation, the amount of data generated and how to interpret it becomes an issue. In Paper G the idea was to take a different approach and use another method that would be more quantifiable. The approach in Paper G can be applied to other circuits and setups if suitable model representations can be found.

R.Q. 6: What consequences do robustness studies have on plant design?

Answer: One of the outcomes is that a plant design inherently should have robust properties, in other words not be sitting on an unstable equilibrium point like the simulated case in Figure 6.13. To be able to cope with the variations, present adjustability is needed. For example, it should be possible to balance the load between multiple sub-circuits. Another outcome in Paper D was that too small storage units within the circuit could cause instability and interlocking effects. This result was also supported by Paper G. These conclusions should be further formalized into a more comprehensive list, similar but longer than the one presented in Paper D. Another way is to formalize the process of choosing design parameters for a closed-loop crushing stage as done in Paper G. To address the shortcomings of Paper D, in Paper G a set of parameters are used in the calculations. These can be added to the list of design and operational variables. The list of parameters can include, for example, conveyor delays, bin volumes, the capacity of machines, and desired split ratio over a screen. Paper D and Paper G together move the front line forward in how plant and circuits should be designed. This thesis's results also highlight the importance of including control and controllability concepts in the design phase of a plant.

R.Q. 7: How can models based on fundamental principles be used to improve plant control?

Answer: Multiple areas of improvement have been demonstrated in this research, first in Paper C, the understanding of what primary response different unit operations have can be gained by developing fundamental models. The models within the controller rely on an understanding of how the equipment works for successful implementation. If a controller model will work, it comes down to whether it is valid for the process it describes. The validity of the control model can range, and it will affect how well it performs as a control model for a specific unit. Secondly, having a high fidelity model available, plant control can be tested off-line with the model, which was done in both Paper C and E. Apart from being able to develop the controller off-line it is also an action that reduces risk as when the control solution is deployed on the real plant as it is already 90-95% tuned, and most bugs have been found. The success of deploying controllers relies on tuning and validating the high fidelity process model as demonstrated by Steyn & Brown [45], which highlights the importance of the aspects described in Section 2.2. A high fidelity process models allow for tuning of, for example, PID-based SISO-loops on the plant in a greenfield project before the plant exists. Additionally, the insights from Paper D and Paper G were possible due to the understanding of how these types of processing plants can be described.

R.Q. 8: What methods are used for transitioning from the high fidelity modeling domain to the control modeling domain?

Answer: To develop control models, an understanding of both the control methods and the phenomena being described is needed. The choice of control method may depend on what is being attempted. In Paper C, linear MPC was used, and this had requirements on the model structure. Secondly, as discussed in Paper D and Paper G, different units have different first-order responses; trying to use these first-order responses is a good start for making a control model. Other methods could be linearization or a structure where the model is updated depending on where it is in its operating range. In Paper G frequency domain models were used. The idea originates in high fidelity modeling and understanding of the units, in this case, used together with PI controllers to study robustness.

7.2 Future work

The future work within this research will focus on the following:

- Further develop the capabilities with dynamic modeling with high fidelity models of machines and processes with a wide range of applications.
- Validate the results and insights from robustness investigations and studies on plant design and operation with lab or scale experiments.
- Develop and test a digital twin of a minerals processing circuit and explore how it can be used to improve performance. Performance can be in terms of cost per unit recovered ore or resources used per mined unit of rock.
- Highlight the advances that can be achieved with simulation for the industry to make the industry more efficient and ultimately have a smaller impact on our ecosystem.

Apart from the above listed points, validation tests of all models and controllers will be on the agenda. The validation and implementation have to be done with industry collaboration, ensuring that the research is utilized and can be benefited from.

Bibliography

- [1] Gauti Asbjörnsson. *Crushing Plant Dynamics*. Chalmers University of Technology, 2015 (cit. on pp. 7, 15, 16, 53).
- [2] Gauti Asbjörnsson, Erik Hulthén, and Carl Magnus Evertsson. “Modelling Dynamic Behaviour of Storage Bins for Material Handling in Dynamic Simulations”. In: *XXVI International Mineral Processing Congress (IMPC 2012: Innovative Processing for Sustainable Growth; New Delhi; India; 24 September 2012 through 28 September 2012)*. 2012, pp. 258–267 (cit. on p. 20).
- [3] LG Austin. “Capacity of high-pressure grinding rolls”. In: *Fuel and Energy Abstracts*. Vol. 1. 37. 1996, p. 4 (cit. on p. 18).
- [4] LG Austin, DR Van Orden, and JW Perez. “A preliminary analysis of smooth roll crushers”. In: *International Journal of Mineral Processing* 6.4 (1980), pp. 321–336 (cit. on p. 18).
- [5] Namik A Aydougan, Levent Ergun, and Hakan Benzer. “High pressure grinding rolls (HPGR) applications in the cement industry”. In: *Minerals Engineering* 19.2 (2006), pp. 130–139 (cit. on p. 18).
- [6] Per Bak, Chao Tang, and Kurt Wiesenfeld. “Self-organized criticality”. In: *Physical review A* 38.1 (1988), p. 364 (cit. on p. 19).
- [7] Gabriel KP Barrios and Luis Marcelo Tavares. “A preliminary model of high pressure roll grinding using the discrete element method and multi-body dynamics coupling”. In: *International Journal of Mineral Processing* 156 (2016), pp. 32–42 (cit. on p. 19).
- [8] GKP Barrios and LM Tavares. “SIMULATION OF A LABORATORY SCALE HPGR USING DEM”. In: () (cit. on p. 19).
- [9] Magnus Bengtsson. *Quality-driven production of aggregates in crushing plants*. Chalmers University of Technology, 2009 (cit. on p. 7).
- [10] H Benzer, L Ergun, AJ Lynch, M Oner, A Gunlu, IB Celik, and N Aydogan. “Modelling cement grinding circuits”. In: *Minerals Engineering* 14.11 (2001), pp. 1469–1482 (cit. on p. 18).
- [11] Paul W Cleary and Mark L Sawley. “DEM modelling of industrial granular flows: 3D case studies and the effect of particle shape on hopper discharge”. In: *Applied Mathematical Modelling* 26.2 (2002), pp. 89–111 (cit. on p. 19).

- [12] Charles R Cutler and Brian L Ramaker. “Dynamic matrix control?? a computer control algorithm”. In: *Joint automatic control conference*. 17. 1980, p. 72 (cit. on p. 20).
- [13] Michael John Daniel and Stephen Morrell. “HPGR model verification and scale-up”. In: *Minerals Engineering* 17.11 (2004), pp. 1149–1161 (cit. on p. 19).
- [14] Alexander Domahidi and Juan Jerez. *FORCES Professional*. embotech GmbH (<http://embotech.com/FORCES-Pro>). July 2014 (cit. on p. 22).
- [15] Carl Magnus Evertsson. *Cone Crusher Performance*. Doktorsavhandlingar vid Chalmers tekniska högskola. Ny serie, no: 1551. Institutionen för maskin- och fordonskonstruktion, Chalmers tekniska högskola, 2000. ISBN: 91-7197-856-9 (cit. on pp. 7, 11, 13, 17, 26, 28, 29, 63).
- [16] Carl Magnus Evertsson. “Prediction of size distributions from compressing crusher machines”. In: *Proceedings of EXPLO 95 Conference*. 1995 (cit. on pp. 28, 29).
- [17] Carl Magnus Evertsson and RA Bearman. “Investigation of interparticle breakage as applied to cone crushing”. In: *Minerals Engineering* 10.2 (1997), pp. 199–214 (cit. on p. 29).
- [18] Merrill Anthony Ford. “Simulation of ore dressing plants”. PhD thesis. Faculty of Engineering, University of Witwatersrand, 1979 (cit. on p. 6).
- [19] Merrill Anthony Ford and RP King. “The simulation of ore-dressing plants”. In: *International Journal of Mineral Processing* 12.4 (1984), pp. 285–304 (cit. on p. 6).
- [20] DW Fuerstenau, A Shukla, and PC Kapur. “Energy consumption and product size distributions in choke-fed, high-compression roll mills”. In: *International Journal of Mineral Processing* 32.1-2 (1991), pp. 59–79 (cit. on p. 18).
- [21] K Gauldie. “The performance of jaw crushers”. In: *Engineering, Oct 9* (1953) (cit. on p. 17).
- [22] C González-Montellano, Eutiquio Gallego, Álvaro Ramírez-Gómez, and Francisco Ayuga. “Three dimensional discrete element models for simulating the filling and emptying of silos: analysis of numerical results”. In: *Computers & chemical engineering* 40 (2012), pp. 22–32 (cit. on p. 19).
- [23] JA Herbst, MA Mular, WT Pate, and X Qui. “Detailed modeling of an HPGR/HRC for prediction of plant scale unit performance”. In: *International Autogenous Grinding, Semiautogenous Grinding and High Pressure Grinding Rolls Technology 2011*. CIM. 2011, pp. 1–20 (cit. on p. 19).
- [24] Johan Hultén. *Drum brake squeal*. Chalmers University of Technology, 1998 (cit. on p. 13).
- [25] *Industry Value Chain: Understand its Importance and Application to the Mining Industry*. <https://flevy.com/blog/industry-value-chain-understand-its-importance-and-application-to-the-mining-industry/>. Accessed: 2021-01-20 (cit. on p. 4).

- [26] MARCUS JOHANSSON. “Modeling and control of a crushing circuit for platinum concentration,” in: (2017). MSc Thesis, 2017 (cit. on pp. 35, 39, 58).
- [27] Elisabeth Lee. *Optimization of Compressive Crushing*. Doktorsavhandlingar vid Chalmers tekniska högskola. Ny serie, no: 3395. ISSN: 0346-718X. 72. 2012. ISBN: 978-91-7385-714-7 (cit. on pp. 11, 26, 28, 29).
- [28] B Légaré, J Bouchard, and É Poulin. “A modular dynamic simulation model for comminution circuits”. In: *IFAC-PapersOnLine* 49.20 (2016), pp. 19–24 (cit. on p. 16).
- [29] Daniel Legendre and Ron Zevenhoven. “Assessing the energy efficiency of a jaw crusher”. In: *Energy* 74 (2014), pp. 119–130 (cit. on p. 17).
- [30] Bengt Lennartson. *Reglerteknikens grunder*. Vol. 4. 6. Studentlitteratur, 2000 (cit. on p. 22).
- [31] Mats Lindqvist and Carl Magnus Evertsson. “Liner wear in jaw crushers”. In: *Minerals Engineering* 16.1 (2003), pp. 1–12 (cit. on p. 17).
- [32] Lennart Ljung and Torkel Glad. *Modeling of dynamic systems*. PTR Prentice Hall Englewood Cliffs, 1994 (cit. on pp. 10, 11, 25).
- [33] Tien-Fu Lu and Shihong Xu. “A fast stockpile simulation engine and its application in mineral ore handling”. In: *International Journal of Modeling, Simulation, and Scientific Computing* 4.02 (2013), p. 1250031 (cit. on p. 19).
- [34] *MATLAB Robust control system Toolbox*. The MathWorks, Natick, MA, USA. 2020b (cit. on pp. 23, 33).
- [35] Sven Erik Mattsson, Hilding Elmqvist, and Martin Otter. “Physical system modeling with Modelica”. In: *Control Engineering Practice* 6.4 (1998), pp. 501–510 (cit. on p. 16).
- [36] Hans von Michaelis. “Real and potential metallurgical benefits of HPGR in hard rock ore processing”. In: *Proceedings of the Randol Innovative Metallurgy Forum*. 2005, pp. 31–39 (cit. on p. 18).
- [37] Manfred Morari and Jay H Lee. “Model predictive control: past, present and future”. In: *Computers & Chemical Engineering* 23.4 (1999), pp. 667–682 (cit. on pp. 20, 21).
- [38] S Morrell, W Lim, F Shi, and L Tondo. “Modelling of the HPGR crusher”. In: *Comminution Practices* (1997), pp. 117–126 (cit. on p. 18).
- [39] Bubele Papy Numbi and Xiaohua Xia. “Systems optimization model for energy management of a parallel HPGR crushing process”. In: *Applied Energy* 149 (2015), pp. 133–147 (cit. on p. 44).
- [40] Moses Frank Oduori, Stephen Mwenje Mutuli, and David Masinde Munyasi. “Analysis of the single toggle jaw crusher kinematics”. In: *Journal of Engineering, Design and Technology* 13.2 (2015), pp. 213–239 (cit. on p. 17).

- [41] MS Powell, MM Hilden, Carl Magnus Evertsson, Gauti Asbjörnsson, AH Benzer, AN Mainza, LM Tavares, B Davis, N Plint, and C Rule. “Optimisation opportunities for HPGR circuits”. In: *11th AusIMM Mill Operators’ Conference*. 2012 (cit. on p. 19).
- [42] H Puhl. “On the modelling of real sand piles”. In: *Physica A: Statistical Mechanics and its Applications* 182.3 (1992), pp. 295–319 (cit. on p. 19).
- [43] PwC. *Mine 2020*. Tech. rep. PwC, June 2020 (cit. on p. 3).
- [44] Johannes Quist. *DEM Modelling and Simulation of Cone Crushers and High Pressure Grinding Rolls*. Doktorsavhandlingar vid Chalmers tekniska högskola. Ny serie, no: 4225. Institutionen för produkt- och produktionsutveckling, Produktutveckling, Chalmers tekniska högskola, 2017. ISBN: 978-91-7597-544-3 (cit. on pp. 18, 19).
- [45] R. J. Fouchee R. P. Brown C. W. Steyn. “Improving crusher performance by comparing various control strategies using a validated simulation”. In: *In proceedings for the MEI 10th International Comminution Symposium (Comminution ’16)* 10 (2016) (cit. on pp. 11, 16, 66).
- [46] James Blake Rawlings and David Q Mayne. *Model predictive control: Theory and design*. Nob Hill Pub., 2009 (cit. on p. 38).
- [47] CM Rule, DM Minnaar, and GM Sauermann. “HPGR-revolution in platinum?” In: *Journal of the Southern African Institute of Mining and Metallurgy* 109.1 (2009), pp. 23–30 (cit. on p. 19).
- [48] Andrew G Salinger, Rutherford Aris, and Jeffrey J Derby. “Modeling the spontaneous ignition of coal stockpiles”. In: *AIChE Journal* 40.6 (1994), pp. 991–1004 (cit. on p. 19).
- [49] Daniel Sbárbaro and René Del Villar. *Advanced control and supervision of mineral processing plants*. Springer Science & Business Media, 2010 (cit. on p. 16).
- [50] K Schönert. “Aspects of the physics of breakage relevant to comminution”. In: *Fourth Tewksbury Symposium, University of Melbourne*. Vol. 3. 1. 1979, pp. 3–30 (cit. on p. 17).
- [51] K Schönert and U Sander. “Shear stresses and material slip in high pressure roller mills”. In: *Powder technology* 122.2-3 (2002), pp. 136–144 (cit. on p. 18).
- [52] Klaus Schönert. “A first survey of grinding with high-compression roller mills”. In: *International Journal of Mineral Processing* 22.1-4 (1988), pp. 401–412 (cit. on pp. 11, 17, 18).
- [53] Sigurd Skogestad and Ian Postlethwaite. *Multivariable feedback control: analysis and design*. Vol. 2. Wiley New York, 2007 (cit. on pp. 22, 23, 33, 38).
- [54] Vasyl Skorych, Maksym Dosta, and Stefan Heinrich. “Dyssel—An open-source flowsheet simulation framework for particulate materials”. In: *SoftwareX* 12 (2020), p. 100572 (cit. on p. 16).

-
- [55] Piotr Tatjewski. *Advanced control of industrial processes: structures and algorithms*. Springer Science & Business Media, 2007 (cit. on p. 8).
- [56] WJ Whiten. “The simulation of crushing plants with models developed using multiple spline regression”. In: *Journal of the Southern African Institute of Mining and Metallurgy* 72.10 (1972), pp. 257–264 (cit. on p. 6).
- [57] Barry A Wills and Tim Napier-Munn. *Wills’ mineral processing technology: an introduction to the practical aspects of ore treatment and mineral recovery*. Butterworth-Heinemann, 2015 (cit. on pp. 4, 16, 17).

