



CHALMERS  
UNIVERSITY OF TECHNOLOGY

# The need for a prospective perspective in LCA

76th LCA Discussion Forum

Rickard Arvidsson

Environmental Systems Analysis

[rickard.arvidsson@chalmers.se](mailto:rickard.arvidsson@chalmers.se)







e 400 ml - 460g

**TOMATO  
KETCHUP**

57 VARIETIES

PNT3330

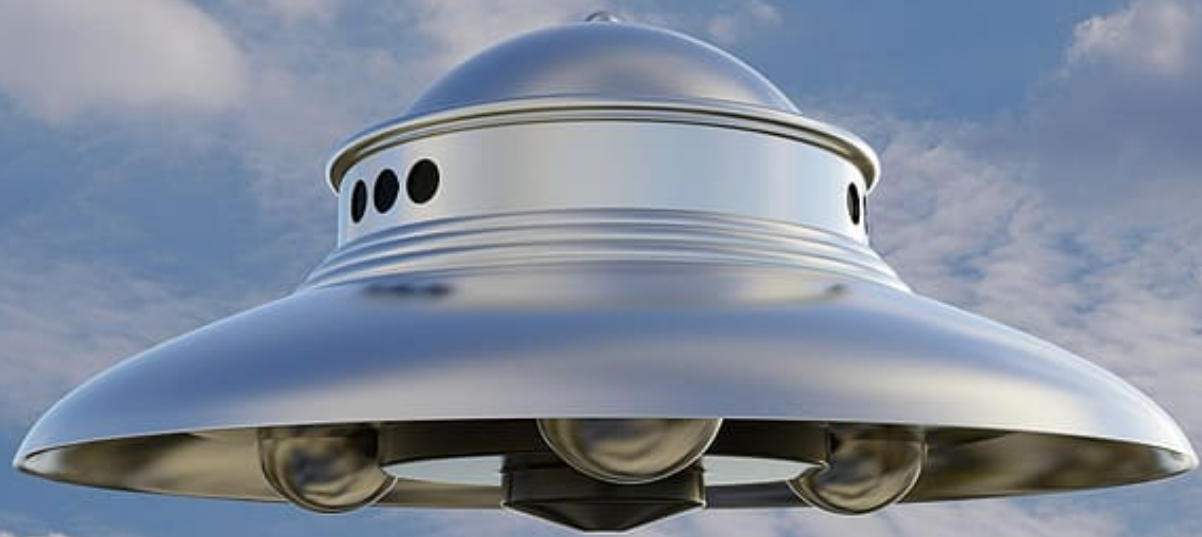

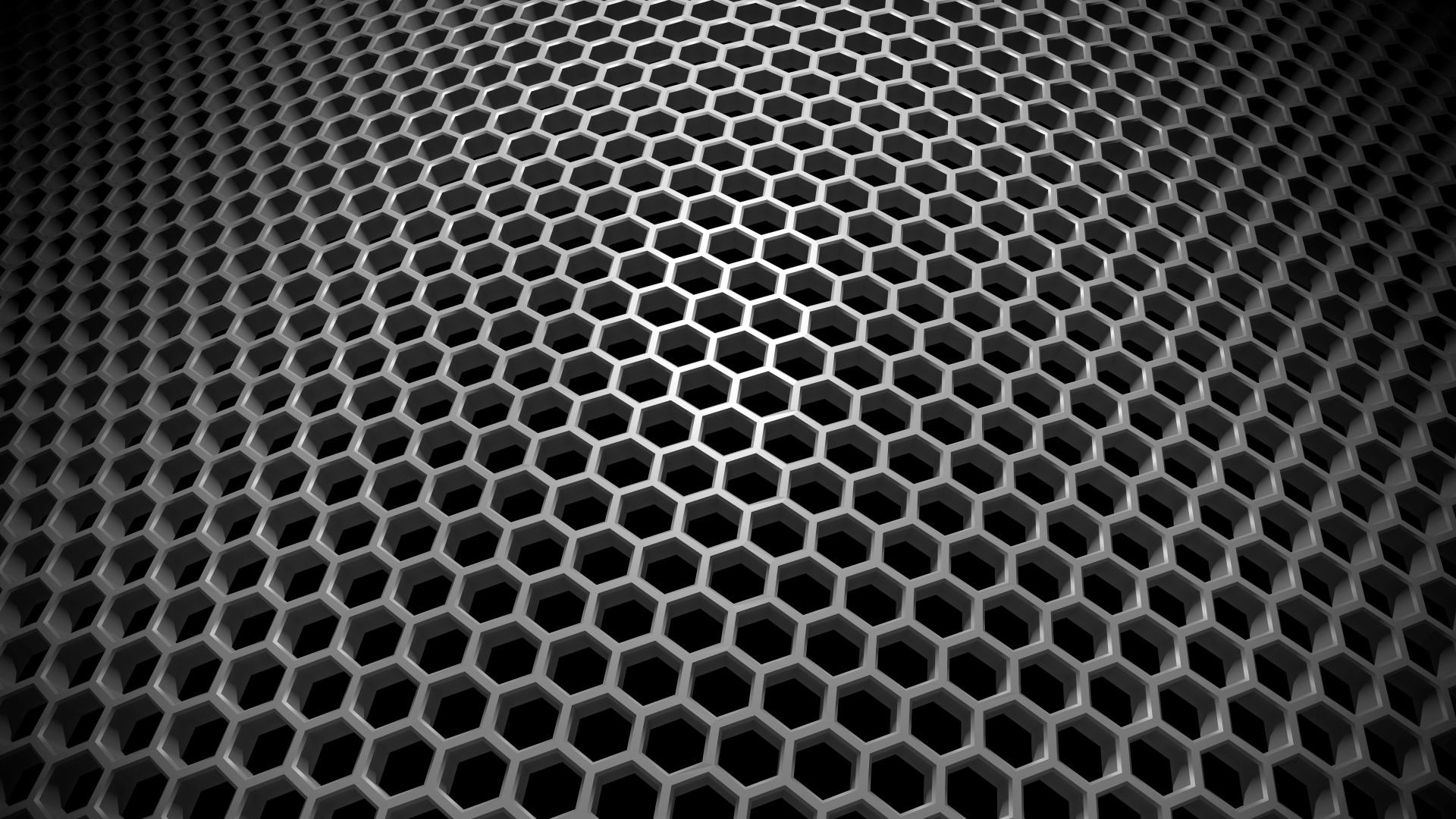

# Problems with conventional LCA of emerging technologies

1. Technologies might change over time

**Table 1.** Typical **lead-acid battery** and electric vehicle performance.

Battery and vehicle assumptions	Vehicle scenarios	
	Available technology	Goal technology
Energy density of battery (Wh/kg)	18	56
Number of driving cycles per battery	450	1,000
Vehicle energy requirements (Wh/km)	310	310
Average distance per driving cycle (km)	80	80
Energy for driving cycle (kWh)	25	25
Battery mass for driving cycle (kg)	1,378	443
Battery life-cycle distance (km)	36,000	80,000
Lead percentage of battery mass (%)	70	70
Battery lead mass (kg)	964	310
Battery lead per life-cycle kilometer (g/km)	27	4
Lead releases per life-cycle kilometer		
Virgin production (4%) (mg/km)	1,072	155
Recycling production (2%) (mg/km)	536	78
Battery manufacture (1%) (mg/km)	268	39

## Problems with conventional LCA of emerging technologies

1. Technologies might change over time
2. Production processes might change over time



CHALMERS  
UNIVERSITY OF TECHNOLOGY

## Lab-scale production

- No solvent recycling
- High yields *OR* high quality with low yields
- Different energy requirement
- Byproducts not utilized



## Problems with conventional LCA of emerging technologies

1. Technologies might change over time
2. Production processes might change over time
3. Surrounding systems might change over time



Rb

Br

Li

U

B

I

Sr



CHALMERS  
UNIVERSITY OF TECHNOLOGY

# Prospective

or

# ex-ante

# LCA



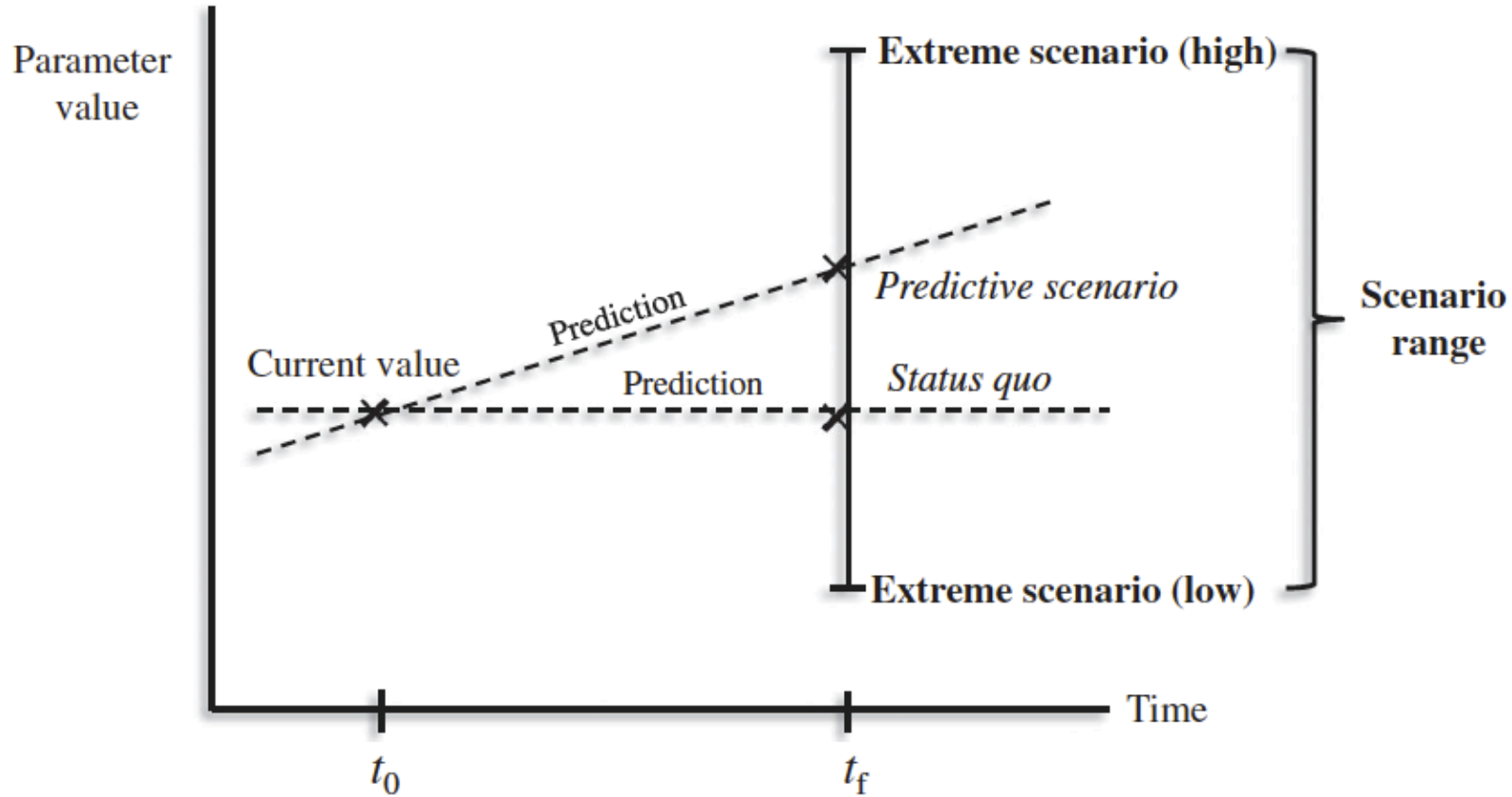

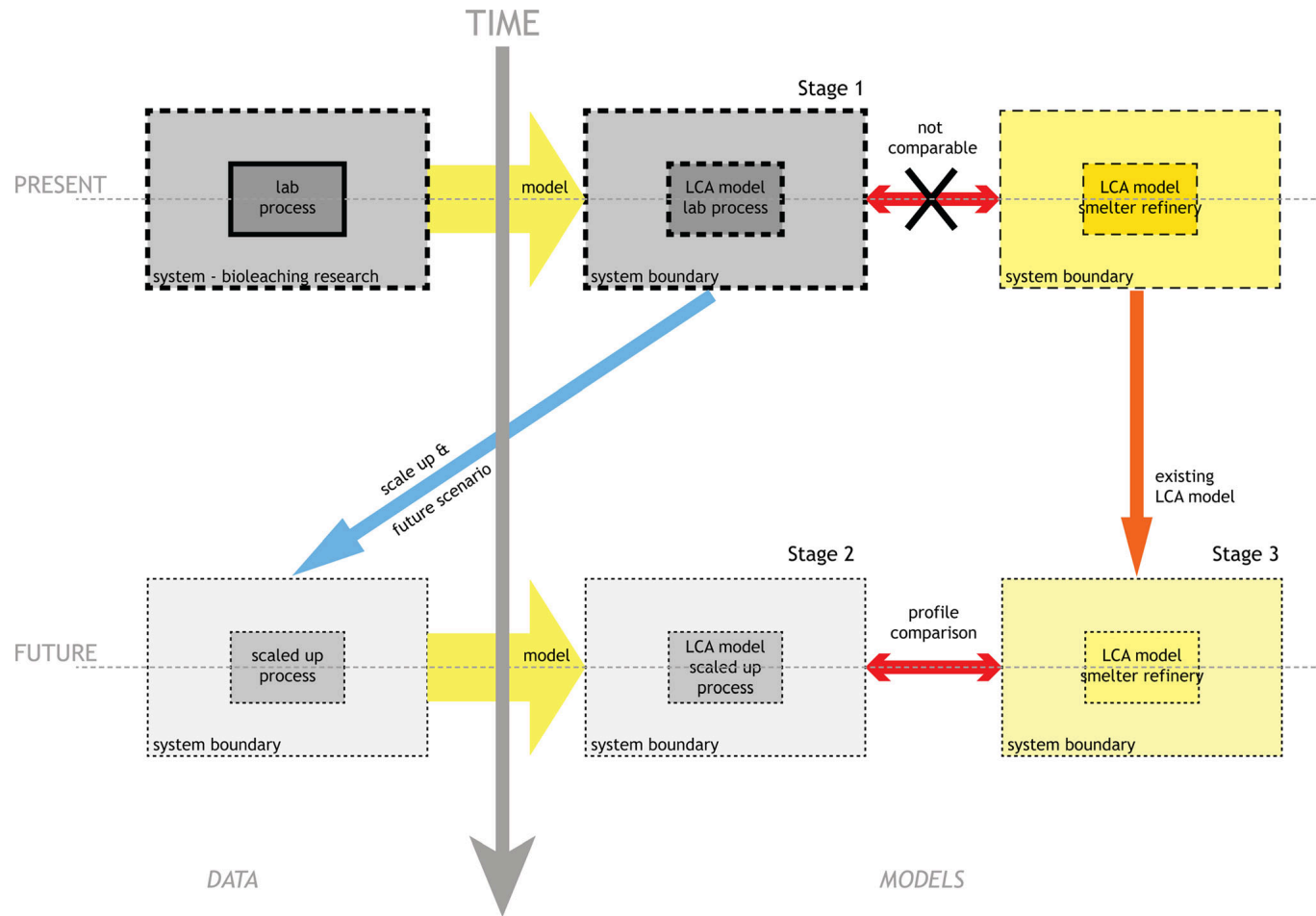

Villares et al. 2017. *Int J LCA*22(10): 1618-1633.

# Bonus slide!

## Prospective vs Consequential and Attributional LCA

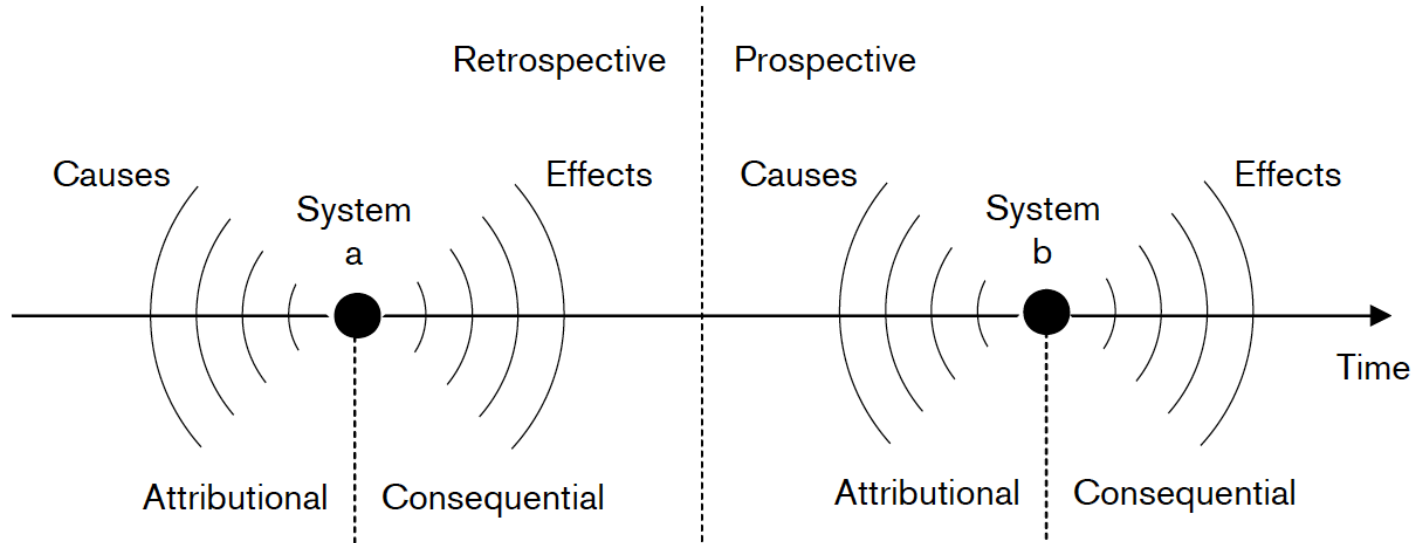

# How to actually do the up-scaling / prediction / scenarios?

× 0.1

$$E_{stir(1000\ l)} = \frac{0.79 * \rho_{mix} * 1.417^3\ s^{-3} * 0.373^5\ m^5 * t}{0.9}$$

$$= 0.0180\ m^5 s^{-3} * \rho_{mix} * t$$

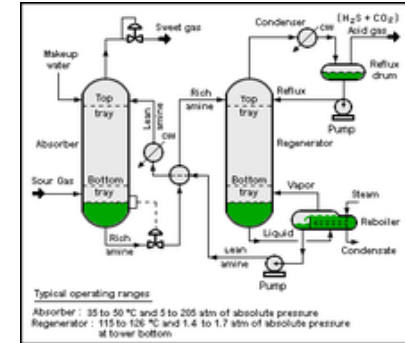

Simplified

In between

Complicated

**Table 1**

Translation of laboratory to large-scale processes according to the presented framework.

Laboratory scale process	Scaled-up process according to framework
Reaction under heating	Heated liquid batch reaction in an insulated batch reactor with an in-tank stirrer
Mixing (magnetic stirrer) Dispersing	In-tank stirring
Blending Mixing (viscous solution) Homogenizing (all types) Dispersing	Rotor-stator type homogenizer
Pestling in mortar Grinding/milling Other particle size reduction	Grinding
Filtration (e.g. membrane, reverse osmosis, dialysis) Sieving Centrifugation/cyclonic separation Other solid–liquid separation	Filtration/centrifugation
Distillation (Rotary evaporation)	Distillation
Vacuum drying Drying Rotary evaporation	(Oven) drying/vaporization
(Manual) Transferring of liquids	Pumping
Waste disposal	Pre-treatment (case specific) Solvent recycling – distillation Solvent recycling – filtration Co- and by-product isolation
Normally not included in laboratory process	Heat recovery through heat exchangers



## Example, stirring

$$E_{stir} [J] = \frac{N_P * \rho_{mix} * N^3 * d^5 * t}{\eta_{stir}}$$

$$E_{stir(1000)} (l) = \frac{0.79 * \rho_{mix} * 1.417^3 \text{ s}^{-3} * 0.373^5 \text{ m}^5 * t}{0.9}$$

$$= 0.0180 \text{ m}^5 \text{ s}^{-3} * \rho_{mix} * t$$

**Table 2:** Estimated best-case and worst-case default values of the yield (Eq. 2), the solvent recycling factor (Eq. 5), other solvent parameters (Eq. 5), the emission factor (Eq. 6), and utility inputs

Parameter	Reaction phase	Reaction medium	Solvent type	Parameter subgroup	Default values		Unit
					Best-case	Worst-case	
Yield (X)				No major side product	0.97	0.87	–
				Major side product	0.87	0.77	–
Solvent recycle factor ( $f_{recycle}$ )					0.95	0	–
number of solvents used in a process step ( $k_{solvent}$ )	Gas phase	Any	Any		0	1	–
	Liquid phase	Organic	Organic		1	2	–
		Aqueous	Water		1	1	–
		Aqueous	Organic		0	1	–
Total mass of a single solvent $j$ in a process step ( $m_{total\ solvent,j}$ )	Gas phase	Any	Organic		0	4	$\frac{kg_{solvent}}{kg_{product}}$
		Aqueous	Water		0	5	$\frac{kg_{water}}{kg_{product}}$
	Liquid phase	Organic	Organic		0.2	4	$\frac{kg_{solvent}}{kg_{product}}$
		Aqueous	Water		2	7	$\frac{kg_{water}}{kg_{product}}$
		Aqueous	Organic		0	4	$\frac{kg_{solvent}}{kg_{product}}$
Emission factor ( $f_{emission}$ )				$1 \times 10^{-7}$	0.001	–	
Utility inputs for reaction and workup				Steam	1.2	7.7	$\frac{kg}{kg_{product}}$
				Electricity	0.7	5.0	$\frac{MJ}{kg_{product}}$
				Cooling water	70	730	$\frac{kg}{kg_{product}}$
				N <sub>2</sub>	0.06	0.4	$\frac{Nm^3}{kg_{product}}$
Utility inputs for solvent regeneration				Steam	1.5	n.a. <sup>a</sup>	$\frac{kg}{kg_{used\ solvent}}$
				Electricity	0.2	n.a. <sup>a</sup>	$\frac{MJ}{kg_{used\ solvent}}$
				Cooling water	80	n.a. <sup>a</sup>	$\frac{kg}{kg_{used\ solvent}}$
				N <sub>2</sub>	0.01	n.a. <sup>a</sup>	$\frac{Nm^3}{kg_{used\ solvent}}$

<sup>a</sup> n.a. – not applicable because no solvent regeneration assumed

Geisler et al. 2004. *Int J LCA* 9(2): 101-113.

# Main messages



1. Prospective perspective in LCA of emerging technologies is needed because:
  - Technologies change
  - Production processes change
  - Surrounding systems change
2. Prospective/ex-ante LCA is a useful approach for considering such possible changes
3. The big question: How can relevant up-scaling, predictions and scenario construction be done in practice?