



**CHALMERS**  
UNIVERSITY OF TECHNOLOGY

## **Battery modular multilevel management (Bm3) converter applied at battery cell level for electric vehicles and energy storages**

Downloaded from: <https://research.chalmers.se>, 2026-04-05 14:11 UTC

Citation for the original published paper (version of record):

Kuder, M., Schneider, J., Kersten, A. et al (2020). Battery modular multilevel management (Bm3) converter applied at battery cell level for electric vehicles and energy storages. PCIM Europe Conference Proceedings, 1: 1726-1733

N.B. When citing this work, cite the original published paper.

# Battery Modular Multilevel Management (BM3) Converter applied at Battery Cell Level for Electric Vehicles and Energy Storages

Manuel Kuder<sup>1</sup>, Julian Schneider<sup>1,2</sup>, Anton Kersten<sup>3</sup>,  
Torbjörn Thiringer<sup>3</sup>, Richard Eckerle<sup>1</sup>, Thomas Weyh<sup>1</sup>

<sup>1</sup> Bundeswehr University Munich, Germany

<sup>2</sup> STABLE GmbH, Munich, Germany

<sup>3</sup> Chalmers University of Technology, Gothenburg, Sweden

Corresponding author: Manuel Kuder, manuel.kuder@unibw.de

## Abstract

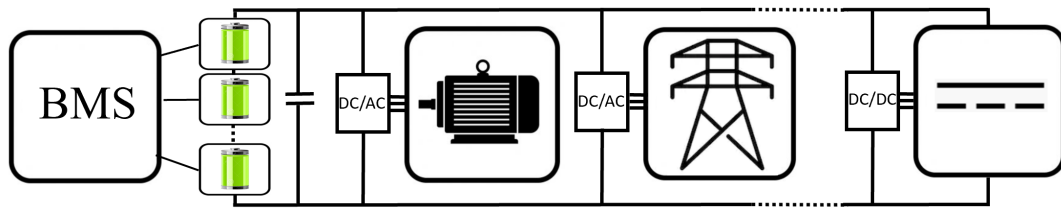
This paper introduces a modular battery system based on an integrated 3-switch inverter topology, referred to as Battery Modular Multilevel Management (BM3) system. The 3-switch topology can be directly applied on battery cell level. In interconnection with the other battery cells, series and parallel connections can be flexibly formed across the battery modules to synthesize any kind of output voltage. In this manner the BM3 topology can work as a flexible DC/AC or DC/DC converter. Furthermore, individual cells can be bypassed, so that each cell can be charged and drained according to their individual capacity. Thus, any additional passive or active balancing circuitry becomes obsolete. Within the frame of this paper's analysis, the basic functionality of the BM3 topology is explained and the possible application as a DC/AC inverter is validated using a small scale prototype setup.

## 1 Introduction

Battery systems both in electric vehicles and as grid storages are considered to be a key technology in order to reduce the dependency on fossil fuels [1]–[3]. Batteries have already become an indispensable component of our daily life, as for example as mobile phone or laptop power supplies and as starter batteries in any combustion engine vehicle. Although, the increase of renewable power generation as well as the demand for electromobility will further increase the need for efficient and reliable electrical energy storage systems. Particularly, integrating the power electronics directly into the battery storage system, as for example shown in [1]–[4], shows large potentials for an enhanced usage of the chemically available capacity, faster charging and battery lifetime extension. Current battery packs or modules consist of hard-wired series and parallel connected battery cells. For example, a Tesla model 3 consists of 96 series connected and 46 parallel connected cells, giving a total amount of 4416 cells [5]. The cell technology and the

cell structure largely determine a cell's electrical characteristics, such as the output voltage, internal resistance, etc. In addition, production tolerances can lead to a substantial variability of properties such as cell capacity and aging rate. Such variability of properties can cause individual cells' state of charge (SOC) to drift apart from other cells. As a consequence, it is necessary to balance the SOC across all cells in a battery pack in order to increase the effective usable capacity and the life time, while preventing any thermal run-aways [6], [7]. Such cell balancing is the key task of available battery management systems (BMS), which match the individual SOC's by active or passive balancing. However, available systems are lossy due to the dissipated energy in bleeding resistors or extra power electronic equipment for moving charges. Furthermore, the lifetime of the cells under certain circumstances can be decreased [7], [8].

This paper presents a battery management system based on a novel multilevel converter topology, which does not require any additional balancing circuitry, in a comparison to a classical two-level inverter drive-train. This new topology is referred to



**Fig. 1:** Conventional power train of modern electric vehicles: different converters are needed for propulsion and DC or AC charging. Furthermore, a designated BMS is needed [1].

as Battery Modular Multilevel Management (BM3). The battery cells can be drained and charged according to their individual capacity, referred to as pro-active balancing. Due to the integration of the power electronics, the output voltage of the battery pack is no longer fixed, but can be dynamically adjusted in small steps. This flexibility of the output voltage enables an optimization of the entire system including the battery, the cell management and the converter with respect to the overall efficiency or quality of the output voltage and current. In addition, it is possible to combine cells with different properties and capacities in one system without additional expenses. This fact particularly includes a second-life use of old cells from different sources in a stationary battery storage. Likewise, it is possible to assemble a system with different cell types to combine advantages and simultaneously compensate shortcomings of different battery cell types. In the following, the working principle of the BM3 modules and the application as a propulsion inverter is explained and demonstrated using a small scale setup.

## 2 State-of-the-Art

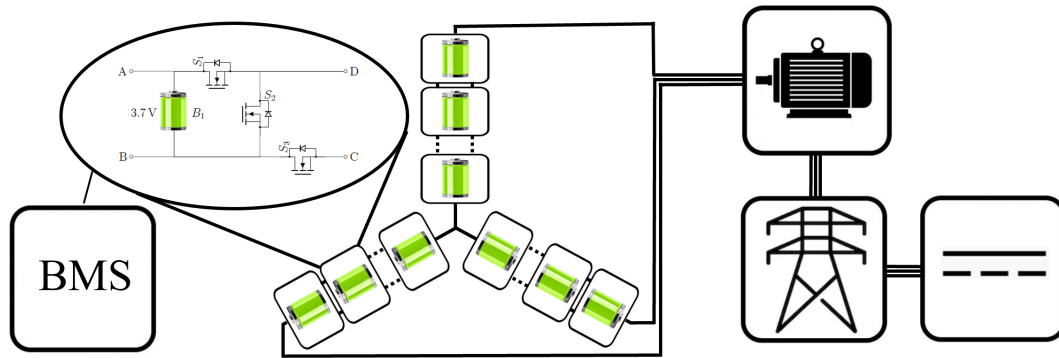
The series-connection of a large number of battery cells in vehicles and stationary batteries achieves terminal battery output voltages between several hundred and a few thousand volts. Such high voltages pose a safety risk, not only to passengers and rescuers in car accidents, but also to roadside assistance and maintenance staff. Therefore, mild-hybrids are often equipped with 48 V batteries [9], which have a limited power capability. Nevertheless, the hard-wired connections of battery cells impedes preventive action in case of an imminent or initiated battery failure. The only possible response is a shutdown of the entire battery pack, which halts the system, but may not solve issues

such as short circuits or thermal run-aways [10]. Furthermore, available battery systems with a high number of battery cells need a designated BMS to balance the state of charge (SOC) of the individual cells. In order to balance the SOC and ensure a safe operation, the BMS has to measure physical parameters, such as voltage, current and temperature of individual cells or cell units, leading to a large number of analog signals [11], [12]. State-of-the-art BMSs use either passive or active balancing. Passive balancing refers to the discharge of individual cells so that all cells are matched in voltage to the cell with the lowest SOC. Discharging, however, completely dissipates the energy in form of heat [6]. In contrast, active balancing transfers charge from full cells to lower charged ones, saving energy. Although, almost no energy is directly wasted, as when using passive balancing, losses are associated with the energy transfer between cells and operating power of the balancing system itself. If not cautiously performed, active balancing can shorten the cell life time, because of rapid-rate charging and discharging [6], [13]. Due to a high control effort and increased system costs, active balancing is rarely used. There are a few exceptions of applications with high energy-density requirements, such as in certain electric vehicles [14], [15] or for aerospace systems [7], [16].

Figure 1 schematically depicts a classical two-level inverter drive system, as for example used in an electric vehicle. As can be seen, not just a traction inverter is needed, also a charging converter either for DC or AC charging is required.

## 3 Converter based on Battery Modular Multilevel Management

The new concept presented in this paper relates to the principles presented in [16]–[18] where



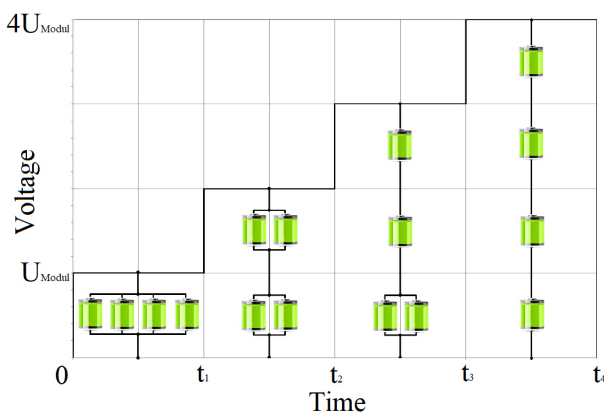
**Fig. 2:** Building a battery storage system with smart batteries. A battery in the figure symbolizes a module and is shown in an enlarged view. A wide variety of output voltage levels can be achieved (step-by-step). Dedicated inverters are eliminated and the BMS is inherently integrated.

dedicated energy storage units are dynamically switched in series and in parallel, as schematically depicted in Fig. 2. Similar concepts have already been evaluated in [19]–[22]. In contrast to a classical two-level inverter drive-train, which only adjusts the battery output voltage to the requirements of the electric motor [23], [24], the Battery Modular Multilevel Management (BM3) system has several functions. Flexible interconnections between the battery cells for an optimal utilization and efficiency of the battery pack can be realized. Separate balancing circuits can be omitted, because these are inherently incorporated. Individual cells can be bypassed, if they are fully charged or defect, and rearranged in series and in parallel to adjust the cells' charge/discharge rate. Furthermore, the output voltage can be realized using fundamental switching. For example, the output voltage synthesis of a sine-wave is depicted in Fig. 3. In each step the battery

pack is reconfigured to have the minimum losses. Furthermore, the converter can be operated as a bidirectional DC/DC converter. Thus, the BM3 concept can be used as a combined propulsion converter and BMS, while the concept can be used as well as a grid connected or DC battery charger. Since each switch must be just dimensioned to block the DC voltage of a single battery cell, cheap low-voltage MOSFETs can be applied. Due to the low switching frequency and the large silicon area distributed among the MOSFETs, any active cooling parts can be eliminated. However, because of the multilevel inverter topology, the battery cells are typically stressed with a slightly increased RMS current (relative to a two-level inverter system [4], [19]).

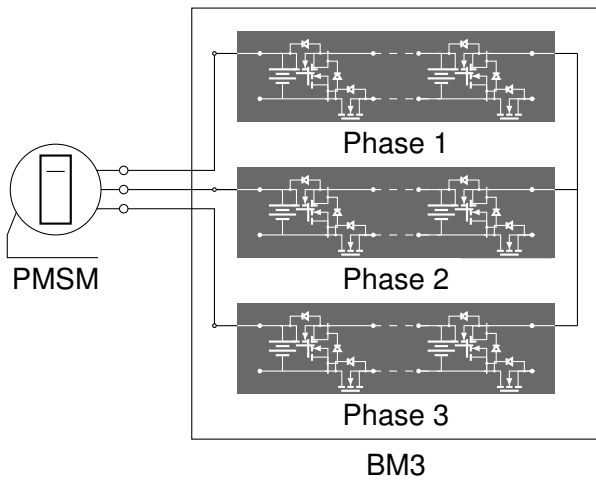
### 3.1 Three-Phase Arrangement

In order to drive an electric three-phase motor in a Y-connection, three sinusoidal voltages with a 120 degree phase shift among each other are required. In case of the BM3 topology, three separate converter strings are necessary, one for each phase. The strands are connected to a star point on the negative side and connected to the machine on the positive side. Figure 4 schematically shows the macrotopology for the operation of a permanent magnet synchronous machine (PMSM). Different authors [3], [26] claim that the 3-switch module can only be used in 2 quadrant operation and, therefore, an additional H-Bridge or a second arm like in a classical Modular Multilevel Converter (MMC) [27] would be required to achieve a polarity reversal. However, when connecting the star point on both sides (load and converter), a star point



**Fig. 3:** Step-wise approximation of a quarter of a sine wave with 4 battery cells [25].

shift takes place, so that both a positive and a negative voltage can be achieved. This is also possible for a delta connection. Therefore, no additional circuitry is needed. In addition to the



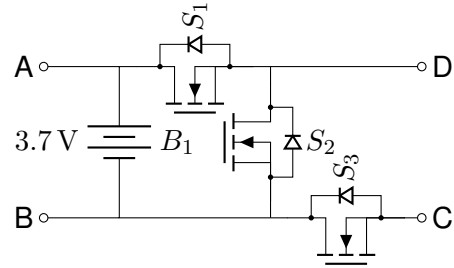
**Fig. 4:** Macrotopology of a BM3 converter for a drive application.

power electronics, other elements for the control and the monitoring of the machine are necessary. A master controller typically reads the machine's rotor position via an encoder signal and uses a current controller to calculate the corresponding voltages for the corresponding phases. Via a communication bus, the switching instants of the individual cells can be transmitted. For this purpose, the current and voltage of each battery string must be measured. The voltage measurement is also important for an under-voltage shutdown/bypassing to protect individual cells from damage [28], [29].

### 3.2 Working Principle of BM3 Module

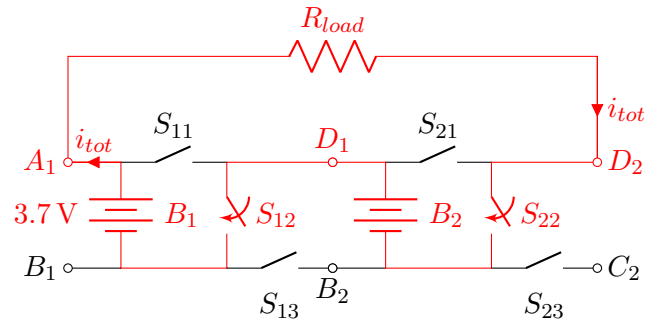
In order to achieve true modularity, each component must be identical and additional central modules, such as DC-link capacitors, must be dispensed. The multilevel functionality is provided by connecting any number of modules in series. Each module can be considered as a two-port network and is based on a combination of three switches per battery cell. Figure 5 shows the arrangement using MOSFETs. For the sake of simplicity, the MOSFETs are indicated by a switch symbol ( $\text{---}$ ) in the following diagrams. Any number of modules can be connected. The terminals "A" and "B" of adjacent module are always connected to the terminals "C" and "D" of the

previous one and vice versa.



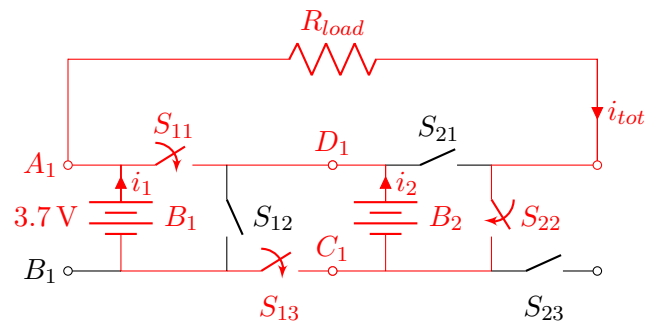
**Fig. 5:** 3-switch module (BM3-Module) with MOSFETs.

Each cell module can have three valid switching states, referred to as serial, parallel and bypass state. Figure 6 shows the connections during the serial state operation. The negative pole of cell  $B_1$  is connected to the positive pole of the next cell through switch  $S_{12}$ . Via  $S_{22}$  the load is connected to the series connected battery string.



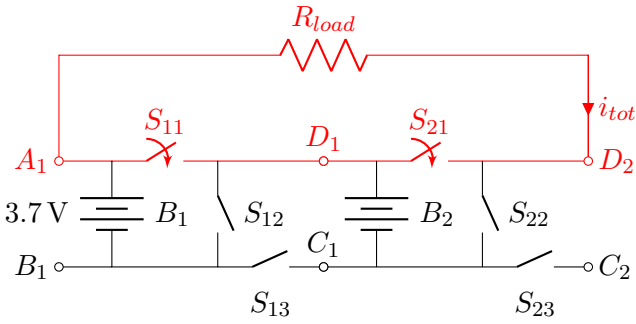
**Fig. 6:** 3-switch modules in serial state operation.

Figure 7 shows the connections during the parallel state operation. The corresponding positive and negative pole of the module is connected to the next cell via the switches  $S_{11}$  and  $S_{13}$ . The current is distributed among the cells according to their impedances.



**Fig. 7:** 3-switch modules in parallel state operation.

The last possibility is the bypass state operation, as shown in Fig.8. The load is connected between

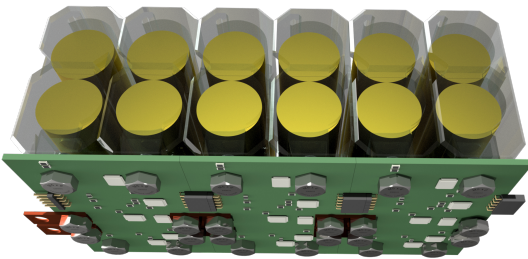


**Fig. 8:** 3-switch modules in bypass state operation.

terminal "A" of the first module and terminal "D" of the last module via the switches  $S_{11}$  and  $S_{21}$ . This configuration can also be used to bypass individual modules in a phase arrangement in case of a faulty or undercharged cell. In the latter case, the cell can be bypassed for a few cycles in order to adjust the voltage/SOC in accordance to the other cells of the strand.

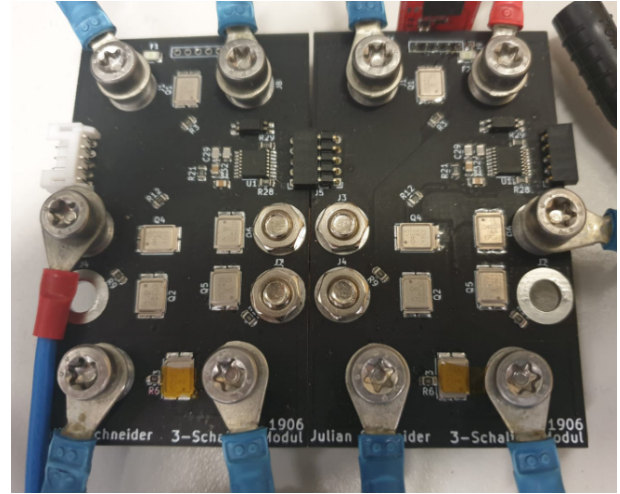
#### 4 Small Scale Prototype

Figure 9 shows a 3-D layout of 3 connected double modules with two battery cells in parallel for each 3-switch module. In principle, any number of modules can be connected to achieve any desired output voltage. When implementing additional battery cells in parallel, the maximum current rating of the switches should be carefully considered, due the additional compensating current during parallel operation.

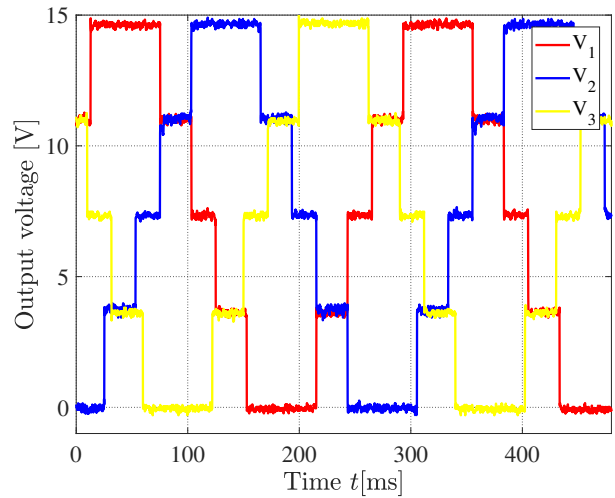


**Fig. 9:** Rendering of several double BM3 modules equipped with 2x6 18650 battery cells [29].

At first, to realize a first small scale prototype, a total number of 12 electrically isolated voltage sources (battery cells) was chosen, so that each of the three phases comprised 4 3-switch modules. The number of modules could be easily expanded to any number of output voltage levels because of the modular design. In this test setup, the low-voltage



(a)

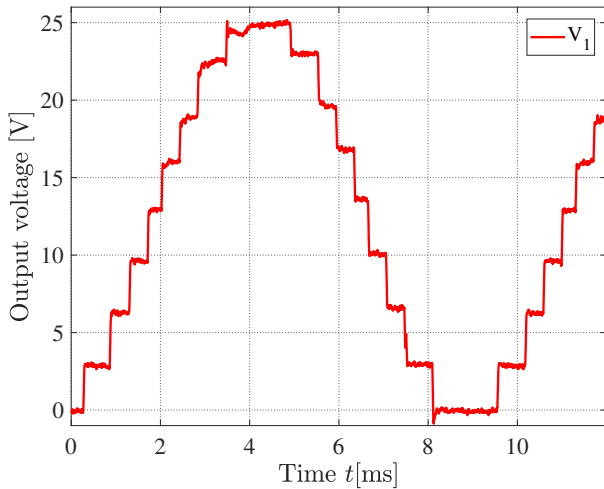


(b)

**Fig. 10:** (a) Test setup with 4 BM3 modules per phase (each PCB contains two 3-switch modules) and (b) proof of concept: three-phase output voltage of 3x4 BM3 modules with neutral point shift.

MOSFETs BSB008NE2LX ( $V_{DS} = 25\text{ V}$ ,  $I_D = 180\text{ A}$ ,  $R_{DS(on)} = 0.8\text{ m}\Omega$ ) from Infineon were used. It was possible to limit the quiescent current to about 1 mA. This was important in order to not have to remove the circuit from the batteries when not in use. For simplicity, the prototype, as shown in Fig. 10(a), was operated using a resistive three-phase load with a nominal resistance of  $100\ \Omega$ . The batteries are represented with 3x4 3.7 V power supplies. The result of the output voltage, shown in Fig. 10(b), proofs the basic functionality of the BM3 in three-phase connection. Just some additional components, as for example three current sensors and a position encoder, would be needed for the

control of an electrical machine[29]. In addition, Fig. 11 shows the output voltage for an extension to eight modules for one phase, resulting in 9 output voltage levels.



**Fig. 11:** Output voltage using 8 stages in single-phase operation.

## 5 Future Perspective

The concept, presented in this paper, is the first step to a new technology, whereas just the basic functionality was demonstrated so far. Further work will be focused on a practical implementation for a 48V drive application. Nonetheless, it is also important to analyze the effect of the topology on the potential increase of the cell life time and the usable cell capacity in comparison to a common passive-balancing BMS. Important is also a quantification of the possible efficiency gain of the BM3 topology.

## 6 Conclusion

With the help of the BM3-topology, the battery is no longer an inflexible static component. Instead, the battery cells can be dynamically connected in series and in parallel, which allows a variable on-the-fly adaption of the system to match both the load voltage and the optimum operation point of each individual cell. Cell balancing, on the other hand, is an inherent function of the circuit, which eliminates the need for any additional circuitry. In addition to a more extensive use of the chemically available capacity, faster charging capabilities, and

an increase of the lifetime, the BM3 enables the combination of cells with different electrical properties, for example different cell technologies or cells with different age. Furthermore, the fault tolerance of the system is increased as defective cells can be bypassed. Instead of halting the entire system, a cell failure only reduces the overall capacitance by the capacitance of the defective cell. As a positive side effect, the system is flexibly expandable: additional submodules (SMs) can just be plugged in without redesigning the system and without accurate matching of the cell parameters. Furthermore, the battery system stops being a dangerous high-voltage DC system when the BM3 is turned off.

## References

- [1] F. Helling, M. Kuder, A. Singer, S. Schmid, and T. Weyh, "Low Voltage Power Supply in Modular Multilevel Converter based Split Battery Systems for Electrical Vehicles", in *2018 20th European Conference on Power Electronics and Applications (EPE'18 ECCE Europe)*, 2018, P.1–P.10.
- [2] A. Kersten, E. Grunditz, and T. Thiringer, "Efficiency of Active Three-Level and Five-Level NPC Inverters Compared to a Two-Level Inverter in a Vehicle", in *2018 20th European Conference on Power Electronics and Applications (EPE'18 ECCE Europe)*, 2018, P.1–P.9.
- [3] F. Helling, S. Götz, and T. Weyh, "A battery modular multilevel management system (BM3) for electric vehicles and stationary energy storage systems", in *2014 16th European Conference on Power Electronics and Applications*, 2014, pp. 1–10. DOI: 10.1109/EPE.2014.6910821.
- [4] A. Kersten, O. Theliander, E. A. Grunditz, T. Thiringer, and M. Bongiorno, "Battery Loss and Stress Mitigation in a Cascaded H-Bridge Multilevel Inverter for Vehicle Traction Applications by Filter Capacitors", *IEEE Transactions on Transportation Electrification*, vol. 5, no. 3, pp. 659–671, 2019. DOI: 10.1109/TTE.2019.2921852.

- [5] J. Rickard, *Tesla Model 3 – NextGen Battery*, <http://evtv.me/2018/05/tesla-model-3-gone-battshit/>, Tesla Model 3 - Battery Description, (Accessed on 03/26/2019).
- [6] J. Cao, N. Schofield, and A. Emadi, "Battery balancing methods: A comprehensive review", in *2008 IEEE Vehicle Power and Propulsion Conference*, 2008, pp. 1–6. DOI: 10.1109/VPPC.2008.4677669.
- [7] M. Uno and K. Tanaka, "Influence of High-Frequency Charge–Discharge Cycling Induced by Cell Voltage Equalizers on the Life Performance of Lithium-Ion Cells", *IEEE Transactions on Vehicular Technology*, vol. 60, no. 4, pp. 1505–1515, 2011. DOI: 10.1109/TVT.2011.2127500.
- [8] R. F. Nelson and M. A. Kepros, "AC ripple effects on VRLA batteries in float applications", in *Fourteenth Annual Battery Conference on Applications and Advances. Proceedings of the Conference (Cat. No.99TH8371)*, 1999, pp. 281–289. DOI: 10.1109/BCAA.1999.796005.
- [9] M. Kuypers, "Application of 48 volt for mild hybrid vehicles and high power loads", SAE Technical Paper, Tech. Rep., 2014.
- [10] A. Kersten, K. Oberdieck, A. Bubert, M. Neubert, E. A. Grunditz, *et al.*, "Fault Detection and Localization for Limp Home Functionality of Three-Level NPC Inverters With Connected Neutral Point for Electric Vehicles", *IEEE Transactions on Transportation Electrification*, vol. 5, no. 2, pp. 416–432, 2019. DOI: 10.1109/TTE.2019.2899722.
- [11] N. A. Chaturvedi, R. Klein, J. Christensen, J. Ahmed, and A. Kojic, "Algorithms for Advanced Battery-Management Systems", *IEEE Control Systems Magazine*, vol. 30, no. 3, pp. 49–68, 2010. DOI: 10.1109/MCS.2010.936293.
- [12] H. Rahimi-Eichi, U. Ojha, F. Baronti, and M. Chow, "Battery Management System: An Overview of Its Application in the Smart Grid and Electric Vehicles", *IEEE Industrial Electronics Magazine*, vol. 7, no. 2, pp. 4–16, 2013. DOI: 10.1109/MIE.2013.2250351.
- [13] C. Bonfiglio and W. Roessler, "A cost optimized battery management system with active cell balancing for lithium ion battery stacks", in *2009 IEEE Vehicle Power and Propulsion Conference*, 2009, pp. 304–309. DOI: 10.1109/VPPC.2009.5289837.
- [14] K. W. E. Cheng, B. P. Divakar, H. Wu, K. Ding, and H. F. Ho, "Battery-Management System (BMS) and SOC Development for Electrical Vehicles", *IEEE Transactions on Vehicular Technology*, vol. 60, no. 1, pp. 76–88, 2011. DOI: 10.1109/TVT.2010.2089647.
- [15] M. Kuder, A. Singer, and T. Weyh, "Multi-Engine in Modular Multilevel Converter based Split Battery Systems for Electric Vehicles", in *PCIM Europe 2019; International Exhibition and Conference for Power Electronics, Intelligent Motion, Renewable Energy and Energy Management*, 2019, pp. 1–7.
- [16] G. C. Bruce and L. Marcoux, "Large lithium ion batteries for aerospace and aircraft applications", in *Sixteenth Annual Battery Conference on Applications and Advances. Proceedings of the Conference (Cat. No.01TH8533)*, 2001, pp. 147–151. DOI: 10.1109/BCAA.2001.905114.
- [17] F. Helling, M. Pfaeffl, J. Huber, S. Goetz, and T. Weyh, "Modular Multilevel Parallel Converter (M2PC) for electrically driven vehicles", in *PCIM Europe 2014; International Exhibition and Conference for Power Electronics, Intelligent Motion, Renewable Energy and Energy Management*, 2014, pp. 1–8.
- [18] M. Kuder, A. Kersten, L. Bergmann, R. Eckerle, F. Helling, and T. Weyh, "Exponential Modular Multilevel Converter for Low Voltage Applications", in *2019 21st European Conference on Power Electronics and Applications (EPE '19 ECCE Europe)*, 2019, P.1–P.11. DOI: 10.23919/EPE.2019.8915156.
- [19] A. Kersten, M. Kuder, E. Grunditz, Z. Geng, E. Wikner, *et al.*, "Inverter and Battery Drive Cycle Efficiency Comparisons of CHB and MMSP Traction Inverters for Electric Vehicles", in *2019 21st European Conference on Power Electronics and Applications (EPE*

- '19 ECCE Europe), 2019, P.1–P.12. DOI: 10.23919/EPE.2019.8915147.
- [20] O. Theliander, A. Kersten, M. Kuder, E. Grunditz, and T. Thiringer, "LiFeP04Battery Modeling and Drive Cycle Loss Evaluation in Cascaded H-Bridge Inverters for Vehicles", in *2019 IEEE Transportation Electrification Conference and Expo (ITEC)*, 2019, pp. 1–7. DOI: 10.1109/ITEC.2019.8790460.
- [21] C. Korte, E. Specht, M. Hiller, and S. Goetz, "Efficiency evaluation of MMSPC/CHB topologies for automotive applications", in *2017 IEEE 12th International Conference on Power Electronics and Drive Systems (PEDS)*, 2017, pp. 324–330. DOI: 10.1109/PEDS.2017.8289145.
- [22] E. Lemmen, J. L. Duarte, and E. A. Lomonova, "Flexbattery — Merging multilevel power conversion and energy storage", in *2016 IEEE Energy Conversion Congress and Exposition (ECCE)*, 2016, pp. 1–7. DOI: 10.1109/ECCE.2016.7855119.
- [23] R. Eckl, "Verfahren und Vorrichtung zur dynamischen Einstellung einer Betriebsspannung für einen Elektromotor", in *PCT Patent WO/2014/023736 2014*, 2014.
- [24] U. I. Dayaratne, S. B. Tennakoon, N. Y. A. Shammash, and J. S. Knight, "Investigation of variable DC link voltage operation of a PMSG based wind turbine with fully rated converters at steady state", in *Proceedings of the 2011 14th European Conference on Power Electronics and Applications*, 2011, pp. 1–10.
- [25] F. Helling, M. Pfaeffl, J. Huber, S. Goetz, and T. Weyh, "Modular Multilevel Parallel Converter (M2PC) for electrically driven vehicles", in *PCIM Europe 2014; International Exhibition and Conference for Power Electronics, Intelligent Motion, Renewable Energy and Energy Management*, 2014, pp. 1–8.
- [26] A. Singer, *Evaluierung einer modularen Umrichtertopologie zur Kombination von Batteriesystemen, Balancing-Systemen, Umrichtern und Ladeschaltung*. 2019, 163 pp.
- [27] A. Lesnicar and R. Marquardt, "An innovative modular multilevel converter topology suitable for a wide power range", in *2003 IEEE Bologna Power Tech Conference Proceedings*, vol. 3, 2003, 6 pp. Vol.3–. DOI: 10.1109/PTC.2003.1304403.
- [28] A. Jossen and W. Weydanz, "Moderne Akkumulatoren richtig einsetzen", 2006.
- [29] J. Schneider, "Modulare Multilevel Umrichter auf Zellebene", EIT7.2, Masterarbeit, Universität der Bundeswehr München, München, 2019, 83 pp.