

THESIS FOR THE DEGREE OF LICENTIATE OF ENGINEERING

Contaminant transport by air infiltration from crawl space to occupant area

Numerical simulations and field measurements in Swedish
schools

FREDRIK DOMHAGEN

Division of Building Technology
Department for Architecture and Civil Engineering
CHALMERS UNIVERSITY OF TECHNOLOGY
Gothenburg, Sweden 2020

Contaminant transport by air infiltration from crawl space to occupant area:

Numerical simulations and field measurements in Swedish schools

Fredrik Domhagen

Copyright © Fredrik Domhagen, 2020.

Technical report no. Lic / Architecture and Civil Engineering / Chalmers University of Technology

Department for Architecture and Civil Engineering

Division of Building Technology

Chalmers University of Technology

SE-412 96 Gothenburg, Sweden

Phone: +46 (0)31 772 68 32

Author e-mail: `fredrik.domhagen@chalmers.se`

Printed by Chalmers Reproservice

Gothenburg, Sweden 2020

Abstract

Some Swedish school buildings built in the 1960's and 1970's have indoor air quality problems. Many of these buildings have a crawl space from which contaminants are suspected to originate. The poor indoor air quality cause discomfort among pupils and teachers and a solution to the problem is not always found.

This thesis summarizes the work done on investigating contaminant transport driven by air leakage from the crawl space to the classroom in such buildings. Field measurements of temperature, wind, and pressure difference across the floor construction between classroom and crawl space has been conducted in two school buildings. A method in which frozen carbon dioxide is used to determine if air leakage to the classroom originates from the crawl space is also successfully tested. Also, a numerical infiltration model is developed in MATLAB and used to investigate how temperature, wind and air permeability distribution affect the pressure difference across the floor construction and contaminant concentrations. The numerical model is also used with the Monte Carlo method to investigate, for example, correlations between model parameters, such as air permeability and temperature, and to analyze measures, such as increased ventilation or use of an exhaust fan in the crawl space.

Results presented in this thesis shows that outdoor temperature and wind has a stronger influence on the concentration levels indoors and the pressure difference across the floor than for example the building airtightness. For buildings

with an imbalanced ventilation system, where the exhaust airflow is larger than the supply airflow the most critical weather case, in terms of high concentrations of contaminants indoors, is during mild and calm days. Numerical simulations also show that the pressure difference across the floor construction is positive (so that air leaks from the crawl space to the classroom) for most weather cases and building configurations.

Keywords: airtightness, air permeability, monte carlo method, infiltration model, crawl space, contaminants

Sammanfattning

Flera av skolbyggnaderna byggda i Sverige under 1960- och 1970-tal har problem med luftkvalitén inomhus. Några av byggnaderna har en krypgrund från vilken föroreningarna misstänks spridas. Den dåliga luftkvaliteten orsakar obehag hos både lärare och elever och det är inte alltid problemen blir lösta.

Den här uppsatsen sammanfattar arbetet som gjorts för att undersöka föroreningstransport genom luftläckage från krypgrund till klassrum i sådana byggnader. Fältmätningar på temperatur, vind och tryckskillnad över bjälklaget mellan krypgrund och klassrum har genomförts på två skolbyggnader.

En metod där frusen koldioxid (torris) används för att avgöra huruvida luftläckage till klassrummet kommer från krypgrunden har testats. En numerisk infiltrationsmodell har även utvecklats i MATLAB. Modellen har använts för att undersöka hur temperatur, vind och luftpermeabilitet påverkar tryckskillnaden över bjälklaget samt föroreningstransport.

Den numeriska modellen har även använts med Monte Carlo metoden för att undersöka, till exempel, korrelationer mellan olika parametrar så som luftpermeabilitet och temperatur. Samt för att analysera åtgärder, som till exempel ökad ventilation i klassrummet eller användning av en frånluftsfläkt i krypgrunden.

Resultat presenterade i uppsatsen visar att utetemperatur och vind har starkare betydelse för koncentrationsnivåerna i klassrummet samt tryckskillnad över bjälk-

laget än till exempel byggnadens lufttäthet. För byggnader med obalanserad ventilation, där frånluftsflödet är större än tilluftsflödet, är det mest kritiska vädret, med avseende på höga koncentrationer i klassrummet, milda och vindstilla dagar. Samt, att tryckskillnaden över bjälklaget är positivt (så att luft läcker från krypgrunden till klassrummet) för det flesta väder och för de flesta byggnader.

Nyckelord: lufttäthet, luftpermeabilitet, monte carlo metoden, infiltrationsmodell, krypgrund

Acknowledgments

This Licentiate thesis summarizes the work carried out at the Division of Building Technology in the building physics modeling group at Chalmers University of Technology. The project has been funded by FORMAS, the Swedish Research Council for Environment, Agricultural Sciences and Spatial Planning and by Lokalförvaltningen in Gothenburg. Lokalförvaltningen has also granted access to a number of school buildings studied in this project.

Foremost, I would like to thank my main supervisor Paula Wahlgren for her guidance, support and our many interesting discussions and for taking me on as a PhD-student. And, also thanks to my co-supervisor Carl-Eric Hagentoft on helpful discussions and valuable input.

Thanks, also to Maria Alm at Lokalförvaltningen for contributing with invaluable insights and providing access to school buildings used in the field studies.

I would also like to thank my colleagues at the division of Building Technology for a good working environment, encouragement and stimulating discussions.

Finally, I would like to thank my family, Malin, Hilde and Liv for your support and for being a daily reminder of what is truly valuable.

Fredrik Domhagen

Gothenburg, November 2020

List of Papers

The work in this thesis is based on the following papers:

- I. Fredrik Domhagen, Paula Wahlgren, Carl-Eric Hagentoft, “Method for Detecting Contaminant Transport through Leakages in a Condemned School” in *7th International Building Physics Conference, IBPC2018*, Syracuse, USA, September, 2018.
- II. Fredrik Domhagen, Paula Wahlgren, Carl-Eric Hagentoft, “Contaminant Transport through the Thermal Envelope – Evaluation of Airflows Based on Numerical Modeling and Field Measurements” in *14th International Conference on Thermal Performance of the Exterior Envelope of Whole Buildings*, Clearwater beach, USA, December, 2019.
- III. Fredrik Domhagen, Paula Wahlgren, Carl-Eric Hagentoft, “Pressure distribution around the thermal envelope - a parametric study of the impact from wind and temperature on contaminant transport within a building” in *12th Nordic Symposium on Building Physics, NSB2020*, Tallin, Estonia, September, 2020.
- IV. Fredrik Domhagen, Paula Wahlgren, Carl-Eric Hagentoft, “Impact of weather conditions and building design on contaminant infiltration from crawl spaces in Swedish schools – numerical modeling using Monte Carlo method” submitted to *Indoor Air*, November 2020.

Paper I describes a method where dry ice is used to determine whether air leakage into the classroom originates from the crawl space or from elsewhere and presents results from field measurements where the method has been tested.

Paper II presents field measurements of pressure difference, temperature, and wind on a school building with indoor air quality problems. Measurements show the importance of stack effect for the pressure difference across the floor construction and that wind may both increase or decrease the pressure difference dependent on several factors such as for example wind direction. Also, a linear regression model is presented and used to analyze the measurement data.

Paper III covers a case study performed with numerical simulations where different weather cases and building configurations are tested. Some conclusions from the paper is that the worst case, in terms of high concentration levels in the classroom, is during mild and calm days. Also, making the floor construction more airtight has a major influence on the pressure difference across the floor construction but minor influence on the concentration level in the classroom.

Paper IV describes how the numerical model from Paper III is used with the Monte Carlo method and presents results from such simulations. Results show, among others, that wind and temperature have a greater influence on concentration levels in the classroom than for example building airtightness.

Contents

Abstract	i
Sammanfattning	iii
Acknowledgements	v
List of Papers	vii
I Summary	1
1 Introduction	3
1.1 Aim	5
1.2 Scope and limitations	6
1.3 Method	6
2 Physical models	9
2.1 Air leakage modeling	9
2.2 Contaminant transport	12
3 Numerical simulations	13
3.1 Description of the numerical model	13
3.2 Normalization of classroom concentrations	19
3.3 Results from numerical simulations	22

3.3.1	Impact from temperature and wind	22
3.3.2	Case study of the impact from temperature, wind and leakage distribution	26
3.4	Monte Carlo simulation	30
3.4.1	Exhaust fan in the crawl space	34
3.4.2	Increased mechanical ventilation in the classroom	35
4	Measurements of pressure difference	39
5	Measurements of leakage paths	43
5.1	Icebox method	43
5.1.1	In situ test	47
6	Conclusions and discussion	53
	References	57
II	Appended papers	63
	Method for detecting contaminant transport through leakages in a con- demned school	65
	Contaminant transport through the thermal envelope – evaluation of airflows based on numerical modeling and field measurements	73
	Pressure distribution around the thermal envelope - a parametric study of the impact from wind and temperature on contaminant transport within a building	85
	Impact of weather conditions and building design on contaminant infil- tration from crawl spaces in Swedish schools – numerical modeling using Monte Carlo method	95

Part I

Summary

Chapter 1

Introduction

Some school buildings built in the 1960's and 1970's in Sweden have indoor air quality problems. The poor indoor air quality causes discomfort among pupils and teachers. In many cases it is difficult to find the source of the problem and it is therefore difficult to find efficient solutions.

Often, the first measure to take, when experiencing indoor air quality problems, is to increase the ventilation rates in the building [1]. If the school building has a crawl space foundation and if it is suspected that the contaminants originate from the crawl space, a common measure is to install an exhaust fan in the crawl space with the purpose of preventing contaminated air from leaking to the classroom. Unfortunately, these measures do not always work, and sometimes the building is left out of service for some time before being demolished.

There are several types of contaminants found in the indoor air in school buildings. Some examples are VOC's (volatile organic compounds), bacteria, formaldehyde, and radon [2]. The sources for these contaminants can be found both in the rooms in the building, within the building envelope and outdoors. Sometimes, the contaminants are results of high moisture levels in the building envelope which can cause increased emissions and mold growth. There are several

studies relating contaminant sources in the building envelope with moisture, for example [3], [4] and [5].

In a Finnish study [6], it was concluded that buildings with a crawl space and with a positive pressure difference across the floor construction could have an increased risk of indoor air quality problems on the first floor (a positive pressure difference means that the pressure is higher in the crawl space than in the classroom). Furthermore, in an investigation of 220 Swedish school buildings built between 1978 and 1997, damages and problems were documented [7]. Some conclusions from the study is that the most widespread problem is mold growth and that there are large deficiencies in airtightness and maintenance. In an interesting example from the study, it is described how unpleasant odor leaks into the classroom from the attic through leakages in the construction.

Contaminants are transported by air movements in the building and follow the direction of the airflow. Air moves from regions of high pressure to regions of low pressure and moves from one room in a building to another through openings. This means that the transport of contaminants within a building depends both on the pressure distribution in the building, occurrence of openings and location of the contaminant sources. Unintentional openings in the construction, that often occur around penetrations and construction joints, depend on several factors such as type of construction and craftsmanship. The pressure distribution in the building depends on pressures caused by mechanical ventilation, stack effect and wind. However, the pressure distribution is also affected by where in the building openings occur. Consequently, the transportation of contaminants because of air leakage depends on a variety of parameters and forms a complex system.

SWESIAQ (Swedish Chapter of International Society of Indoor Air Quality and Climate) is a Swedish chapter of the International Society of Indoor Air Quality and Climate (ISIAQ) and has developed a model for investigating buildings with indoor air quality problems. The model is called the SWESIAQ-model [8] and emphasize (among other things) the importance of measuring the pressure distribution to assure that air is not leaking in an unwanted direction (for exam-

ple from the crawl space to the classroom). However, there is no information on how and when to measure, and there are no recommended tools for assessing the results from such measurements.

A better understanding of how air permeability distribution, mechanical ventilation and weather affect the transport of contaminants from the crawl space to the classroom is needed to make better and more efficient decisions on which measures should be taken when a school building with a crawl space has indoor air quality problems.

1.1 Aim

The aim of this thesis is to investigate school buildings with indoor air quality problems where the contaminant source is situated in the crawl space. This work focus on contaminant transport by air leakage from the crawl space to the classroom and the driving forces for air leakage as well as the effect of air permeability distribution.

The research questions are:

- How can dry ice (frozen carbon dioxide), as a tracer gas, be used as a tool for determining whether air leakage to the classroom comes from the crawl space or from elsewhere?
- Which parameters; wind, temperature or air permeability are most influential on contaminant concentration in the classroom and on the pressure difference across the floor construction between classroom and crawl space?
- What are typical values for pressure difference across the floor construction and what are typical levels for contaminant concentration in the classroom in relation to the source?
- Is depressurizing the crawl space to -5 Pa (compared to the classroom) using an exhaust fan a good measure to prevent air from leaking from the

crawl space to the classroom?

- Is increasing the ventilation in the classroom a good measure to decrease contaminant concentrations in the classroom even though there is a risk of increased flow of contaminants from the crawl space to the classroom?

1.2 Scope and limitations

The work focus on older one-story school buildings built in the 1960's to 1970's with indoor air quality problems and with a crawl space. These buildings typically have an airtightness of about 1.0 l/sm^2 at 50 Pa pressure difference and many buildings have undergone several renovations.

The only contaminant transport mode considered in this work is transportation by air movements between crawl space and classroom as well as from crawl space and classroom out to the exterior. Contaminant concentrations are investigated without considering any specific contaminant. There are no sink effects, for example contaminant absorption, or other time related effects included in the numerical simulations, except from time effects concerning the temperature in the crawl space.

1.3 Method

Several methods are used to investigate contaminant transport by air leakage from the crawl space to the classroom. A numerical infiltration model is developed in the programming software MATLAB. The model is used to study specific cases as well as for doing Monte Carlo simulations.

Field measurements are performed where the pressure difference across the floor construction, wind and temperature is measured in two school buildings. The measurements give hourly values and are performed for several weeks at a time.

Carbon dioxide is used as a tracer gas with the purpose of determining whether

air is leaking to the classroom from the crawl space or from elsewhere. In this method, carbon dioxide is added to the crawl space as dry ice (frozen carbon dioxide) and heated to increase the rate of transition to a gaseous state.

Chapter 2

Physical models

This chapter describes the equations used in analytical analysis and numerical simulations. The equations in this chapter describe how air leakage is calculated dependent on temperature, wind, and mechanical ventilation.

2.1 Air leakage modeling

The total pressure difference across an opening is the driving force for the air-flow. The air leakage through the opening is modeled using the *power law equation*:

$$Q = C (\Delta P)^n \quad (2.1)$$

where Q [m^3/s] is the volume airflow through the opening, ΔP [Pa] is the pressure difference across the opening, C [$m^3/(sPa^n)$] is the airflow coefficient and n [–] is the airflow exponent. Values for C and n depend on the geometries of the air gap and are usually found empirically. However, if n is unknown a value of 0.65 is considered a good estimate [9, 10, 11].

Air is treated as an ideal gas and the density is calculated using the ideal gas

law:

$$\rho = \frac{P_{abs}}{RT} \quad (2.2)$$

where P_{abs} [Pa] is the absolute pressure, T [K] is the temperature and R [J/(kgK)] is the gas constant for dry air ($R = 287.042$) [9].

The pressure difference across an opening is caused by *stack effect* and *wind*. Stack effect is caused by differences in air density on either side of the opening (differences in air density is caused by difference in air temperature).

The pressure difference caused by stack effect across an opening is calculated with the following equation, [12]:

$$\Delta P_{st} = (\rho_1 - \rho_2) \cdot g \cdot z \quad (2.3)$$

where ρ_1 [kg/m³] and ρ_2 [kg/m³] is the density of the air on either side of the opening, z [m] is the distance to the *neutral pressure plane*, NP, and g [m/s²] is the constant of gravitational acceleration.

The *neutral pressure plane* occurs at some height where the pressure difference equals to zero, see Figure 2.1.

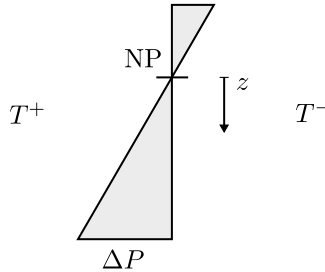

Figure 2.1: Illustration showing how the pressure difference caused by stack effect varies with building height. The pressure difference is equal to zero at the height of neutral pressure plane (NP).

The wind pressure acting on the facade and roof depends on wind speed, surrounding terrain, wind direction relative to the surface and shape of the building. The wind pressure is calculated with the following expression, [12, 13]:

$$P_w = C_p \frac{\rho u^2}{2} \quad (2.4)$$

where C_p [-] is the wind pressure coefficient, ρ [kg/m^3] is the air density and u [m/s] is the wind speed. The wind pressure coefficient, C_p , account for the angle between the incident wind and the surface, building shape and building exposure. Wind pressure coefficients for different building shapes and shielding conditions can be found in [13]. Available shielding conditions are: *exposed*, *height of the surrounding buildings equal to half the height of the studied building* and *height of the surrounding buildings equal to the height of the studied building*.

When there is a difference in height between the weather station, from where the weather data comes, and the height of the building the wind speed needs to be corrected using the following equation [12, 13]:

$$u = u_m \cdot K \cdot r^a \quad (2.5)$$

where u [m/s] is the wind speed at the building height, u_m [m/s] is the wind speed measured by the weather station, r [m] is the height of the building and k and a are terrain coefficients found in, for example, [13].

Stationary air flows through openings and ventilation systems in a building with one or more rooms can be solved by summation of the mass flows of air in and out from each room. The sum of the mass flows must equal zero.

$$\sum \dot{m}_{in} - \sum \dot{m}_{out} = 0 \quad (2.6)$$

where \dot{m} [kg/s] is the mass flow of air.

In reality, airflow caused by mechanical ventilation is pressure dependent. However, in this work, calculations are simplified by assuming pressure independent mechanical ventilation. Mechanical ventilation is accounted for by adding the airflow from ventilation as a mass flow to the balance equation for the ventilated room, Equation 3.4.

2.2 Contaminant transport

Contaminant flow from one room to another (or from a room to the exterior) is calculated with the following expression:

$$G = c \cdot Q \quad (2.7)$$

where G [kg/s] is the flow of contaminants, c [kg/m^3] is the contaminant concentration in the room from which the airflow originates and Q [m^3/s] is the volume air flow from the room.

Chapter 3

Numerical simulations

3.1 Description of the numerical model

A numerical model is written in the programming software MATLAB and is used to calculate air infiltration and contaminant transport from the crawl space to the classroom. The numerical model is a continuation of the model developed in [14] and similar to the models used in simulation tools such as CONTAM [11] and COMIS [15], which have been validated by comparison with measurements in for example [16] and [17]. Validation of the numerical model in this thesis is done primarily by comparison with CONTAM. Also, several comparisons with hand-calculations are made to ensure that the code is working as expected.

The model is simplified to two volumes; one crawl space and one classroom, see Figure 3.1. Air leakage is modeled by defining openings between the volumes as well as between the volumes and the exterior. Air leakage through the openings are modeled using Equation 2.1. Since the pressure difference across the exterior wall varies with building height, because of stack-effect, openings in the walls of the classroom are added at three different heights. One opening at

the bottom of the wall, one opening at the middle of the wall and one opening at the top of the wall. Different numbers of openings have been tested and it was shown that increasing from three openings to four openings or more have no significant effect on the final results. Three openings are therefore considered to be enough.

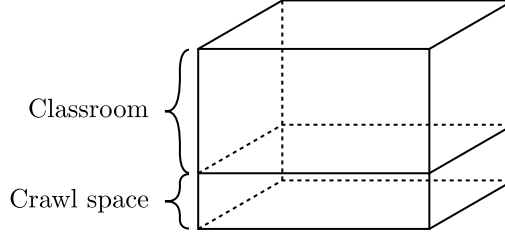

Figure 3.1: Principle drawing of the numerical model.

The pressure difference across the floor construction between the classroom and the crawl space is given by the unknown pressures in the classroom, P_{cr}^{NP} , and the crawl space, P_{cs}^{NP} together with Equation 2.3:

$$\begin{aligned}\Delta P_{floor} &= P_{cr}^{NP} - P_{cs}^{NP} - (\rho_{cr} - \rho_{ex})gz_{cr} + (\rho_{cs} - \rho_{ex})gz_{cs} \\ &= P_{cr}^{NP} - P_{cs}^{NP} + (\rho_{cs} - \rho_{cr})g(z_{cs} - z_{cr})\end{aligned}\quad (3.1)$$

where z_{cr} is the distance from the neutral pressure plane in the classroom to the floor and z_{cs} is the distance from the neutral pressure plane in the crawl space to the floor. The index cr refers to the classroom, cs refers to the crawl space and ex refers to the exterior.

The pressure difference across the thermal envelope is calculated in a similar matter with the addition of the pressure from wind, Equation 2.4:

$$\Delta P_{cr} = P_w - P_{cr}^{NP} + (\rho_{cr} - \rho_{ex})gz \quad (3.2)$$

$$\Delta P_{cs} = P_w - P_{cs}^{NP} + (\rho_{cs} - \rho_{ex})gz \quad (3.3)$$

Mass flow to and from the classroom and the crawl space is then calculated using Equation 2.1 and Equation 2.2. The sum of the air leakages together with the mechanical ventilation makes up the mass balance for the classroom and the crawl space:

$$\sum \dot{m}_{cs \rightarrow cr} + \sum \dot{m}_{ex \rightarrow cr} + \sum \dot{m}_{fan,cr} = 0 \quad (3.4)$$

and

$$\sum \dot{m}_{cr \rightarrow cs} + \sum \dot{m}_{ex \rightarrow cs} + \sum \dot{m}_{fan,cs} = 0 \quad (3.5)$$

where $\dot{m}_{fan,cr}$ is the mass flow to the classroom caused by mechanical ventilation in the classroom and $\dot{m}_{fan,cs}$ is the mass flow to the crawl space caused by mechanical ventilation in the crawlspace.

The system of equations has four unknown variables, (zone pressures) P_{cr}^{NP} , P_{cs}^{NP} and the location of the neutral pressure plane for both the classroom and the crawl space.

However, the number of unknown variables can be reduced to two by assuming a, for the building, common reference plane (for example at the bottom of the building). The height of each opening is defined in relation to the common reference plane and the mass balance is solved by calculating the zone pressures, P_{cr} and P_{cs} .

Figure 3.2 shows an illustration of the distance, d_i between leakage i to the reference plane together with zone pressure and the pressures from stack effect and wind.

It is important to note that the zone pressures, P_{cr} and P_{cs} , are defined differently from P_{cr}^{NP} and P_{cs}^{NP} in Equation 3.1-3.3. Since the stack effect is now calculated from a common reference plane (rather than from the neutral pressure plane) this difference must be compensated by the zone pressures, as shown in Figure 3.2.

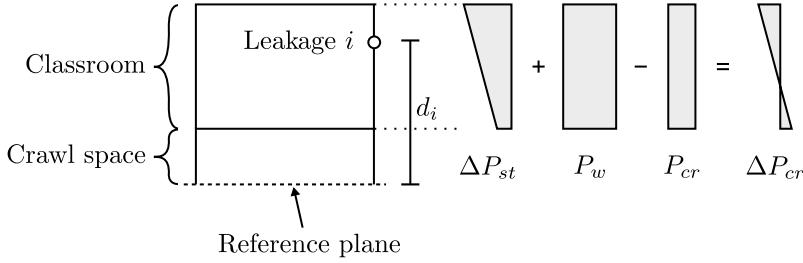

Figure 3.2: Principle drawing of the numerical model where the distance, d_i , between leakage i and the reference plane is shown together with the total pressure difference (ΔP_{cr}) across the thermal envelope caused by pressures from stack effect (ΔP_{st}), wind (P_w) and zone pressure (P_{cr}) in the classroom.

Different ways of solving the mass balance have been tested. However, the approach described above was proven to be the most computationally efficient mainly since the stack effect only needs to be calculated once for every steady-state solution.

Equation 3.4 can together with Equation 2.1, 2.2 and 2.3 be rewritten as:

$$\begin{aligned}
 & \sum_i C_i (P_{cs} - P_{cr} + (\rho_{cr} - \rho_{cs}) g d_i)^n \rho_{cs/cr} + \\
 & + \sum_j C_j (P_{w,j} - P_{cr} + (\rho_{cr} - \rho_{ex}) g d_j)^n \rho_{ex/cr} + \\
 & + \sum \dot{m}_{fan,cr} = 0
 \end{aligned} \tag{3.6}$$

and similarly, Equation 3.5 can be rewritten as:

$$\begin{aligned}
& \sum_i C_i (P_{cr} - P_{cs} + (\rho_{cs} - \rho_{cr}) g d_i)^n \rho_{cs/cr} + \\
& + \sum_j C_j (P_{w,j} - P_{cs} + (\rho_{cs} - \rho_{ex}) g d_j)^n \rho_{ex/cs} + \\
& + \sum \dot{m}_{fan,cs} = 0
\end{aligned} \tag{3.7}$$

Here the indices i and j are opening numbers and d is the distance from the opening to the common horizontal reference plane. For a negative pressure difference inside the parenthesis the flow direction is simply changed (negative sign instead of positive). The density of the air depends on the origin of the leaking air. For example, air leaking from the exterior has the density of the exterior air and vice versa.

Equation 3.6 and Equation 3.7 form a system of two non-linear equations with two unknown variables; P_{cr} and P_{cs} . The system is solved numerically in MATLAB using the Newton-Raphson method [11] and [15].

Once the equation system is solved, the absolute pressure (disregarding wind pressure) in the classroom at height d from the *reference plane* can be calculated with the following equation:

$$P_{abs.cr}(d) = P_{atm}(d) + (\rho_{cr} - \rho_{ex}) g \cdot d - P_{cr} \tag{3.8}$$

and similarly, for the crawl space:

$$P_{abs.cs}(d) = P_{atm}(d) + (\rho_{cs} - \rho_{ex}) g \cdot d - P_{cs} \tag{3.9}$$

where $P_{atm}(d)$ [Pa] is the atmospheric pressure at height d .

A contaminant source is modeled in the crawl space and once the airflows in the building have been solved, the transport of contaminants from the crawl space to the classroom is calculated using the following balance equations:

$$\begin{aligned}
c_{cs} \cdot \sum Q_{cs \rightarrow cr} - c_{cr} \cdot \sum Q_{cr \rightarrow cs} \\
- c_{cr} \cdot \left(Q_{exh} + \sum Q_{cr \rightarrow ex} \right) = 0
\end{aligned} \tag{3.10}$$

and

$$\begin{aligned}
c_{cr} \cdot \sum Q_{cr \rightarrow cs} - c_{cs} \cdot \sum Q_{cs \rightarrow cr} \\
- c_{cs} \cdot \left(Q_{exh.cs} + \sum Q_{cs \rightarrow ex} \right) + G = 0
\end{aligned} \tag{3.11}$$

where G [kg/s] is the contaminant source (independent of temperature and time) in the crawl space, c_{cr} [kg/m^3] is the concentration in the classroom, c_{cs} [kg/m^3] is the concentration in the crawl space, Q [m^3/s] is the volume airflows, Q_{exh} [m^3/s] is the exhaust volume airflow from the classroom and $Q_{exh.cs}$ [m^3/s] is the exhaust volume airflow from the crawl space. There is no background concentration which means that all contaminants originate from the source in the crawl space. Equation 3.10 and Equation 3.11 form a linear system of equations that is solved in MATLAB to get the concentration in the classroom and in the crawl space.

The height of the classroom and the crawl space is, for all simulations, set to 2.8 meter and 1.5 meter respectively. Two different building shapes are simulated, one square shaped and one long shaped, see Figure 3.3.

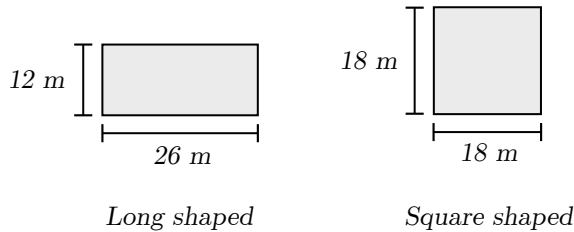

Figure 3.3: Drawing of the two simulated building shapes; long shaped and square shaped.

The temperature in the classroom is set to 21 °C and the temperature of the supply airflow to the classroom is set to 10 °C. The temperature in the crawl space is calculated using the computer software *Crawl* [18]. More information on how the temperature in the crawl space is implemented in the model is found in Paper II.

3.2 Normalization of classroom concentrations

It is practical to normalize the concentration in the classroom. The normalization simplifies comparisons of concentrations in different simulation cases and describes the concentration in relation to the maximum concentration. Also, the normalized concentration makes it possible to recalculate the concentration to any specific contaminant for a given source strength and ventilation rate. The maximum concentration is calculated with the following equation:

$$c_{cr,max} = \frac{G}{Q_{exh}} \quad (3.12)$$

where G [kg/s] is the source strength and Q_{exh} [m^3/s] is the mechanical exhaust airflow from the classroom. The normalized concentration is then calculated with the following equation (illustrated in Figure 3.4.a):

$$c_{cr,N} = \frac{c_{cr}}{c_{cr,max}} \quad (3.13)$$

where c_{cr} [kg/m^3] is the concentration in the classroom.

Figure 3.4 shows four examples of concentrations in the classroom with different air leakage locations. The purpose of the illustrations is to show how the concentration in the classroom and contaminant transport changes as the location of air leakage changes.

In Figure 3.4.a the only driving force for air leakage is caused by the difference in mechanical exhaust and supply airflow. Here, all the contaminants produced in the crawl space enter the classroom and the air change rate in the classroom depends only on the mechanical ventilation. This case yields the maximum concentration in the classroom, where the concentration can be calculated with Equation 3.12. In Figure 3.4.b there is some additional air leakage (caused by wind) through the walls of the crawl space and 80% of the contaminants produced in the crawl space enters the classroom. Figure 3.4.c has no air leakage out from the walls in the crawl space which means that all of the contaminants produced in the crawl space enters the classroom. However, there is some air leakage in the classroom (caused by wind), allowing outdoor air to enter the classroom, which results in a lower concentration compared to Figure 3.4.a. Figure 3.4.d is a combination of the cases in Figure 3.4.b and Figure 3.4.c, where there are air leakages both out from the crawl space and out from the classroom. This case has the lowest concentration in the classroom of all illustrated cases.

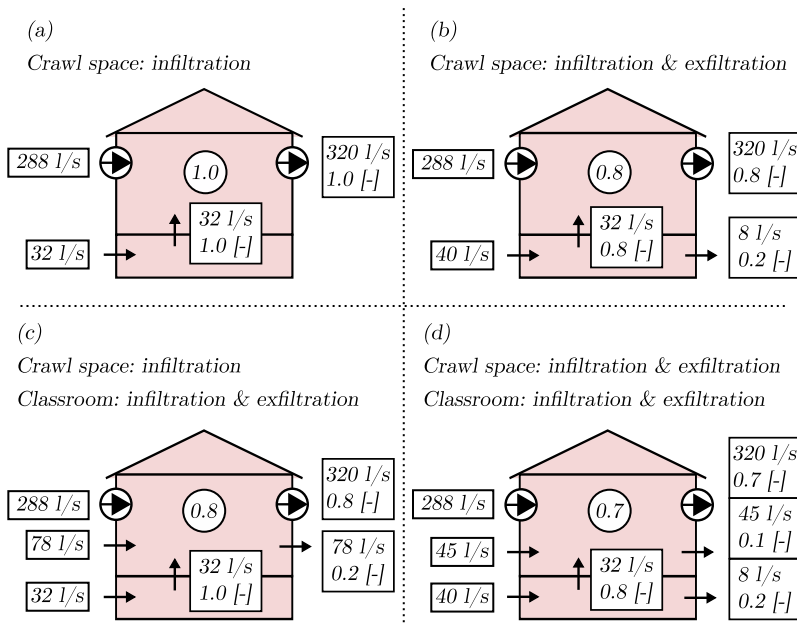

Figure 3.4: Illustration showing four examples of how the concentration levels in the classroom changes as the location of air leakages in the building changes. The value inside the circle shows the normalized concentration in the classroom. Volume airflows are shown together with the share of the contaminant source that exits through the leakage.

These examples show that the worst case scenario in terms of high concentrations in the classrooms happens when there is little wind and the stack effect is such that all the air leaking from the crawl space enters the classroom. If the mechanical ventilation system is causing a positive pressure difference across the floor construction, then the highest concentration in the classroom will occur during mild temperatures outdoors and in the crawl space.

3.3 Results from numerical simulations

The numerical model is used to study several cases. Both the distribution of air permeability in the building and the weather (temperature and wind) affects the pressure difference across the floor construction and the contaminant concentration in the classroom. Different cases are simulated where the air permeability of the building and weather (wind and temperature) is altered with the purpose of investigating the impact on contaminant transport.

A presentation convention is introduced and shown in Figure 3.5 to give an overview of the simulation results for each simulation case. The pressure difference across the floor construction has a positive sign when the air is leaking from the crawl space to the classroom.

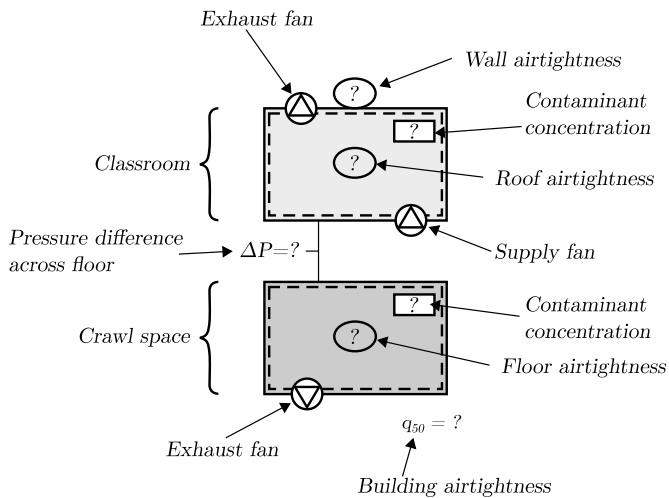

Figure 3.5: Description of the presentation convention used to present results from the case study.

3.3.1 Impact from temperature and wind

In Figure 3.6, 3.7, 3.8 and 3.9 results from simulations are shown for variations in one climate parameter at a time, outdoor temperature, temperature in the

crawl space and wind velocity at two different wind directions. The simulated building has an overall airtightness of 0.97 l/sm^2 and is long shaped as shown in Figure 3.3. Leakages are evenly distributed along the walls. The airtightness of walls (classroom), floor and roof is 1.2 l/sm^2 and the airtightness of the walls in the crawl space is 2.0 l/sm^2 , see also Figure 3.10. The exhaust ventilation airflow is 320 l/s and the supply airflow is 288 l/s . The red dots in Figure 3.6, 3.7, 3.8 and 3.9 shows the concentration in the classroom and the pressure difference across the floor construction when there is no wind, the outdoor temperature is 10°C , and the temperature in the crawl space is 8°C .

In Figure 3.6 the outdoor temperature is increased from -10°C to 25°C . The concentration in the classroom increases with increased outdoor temperature until the outdoor temperature reaches approximately 21°C . The pressure difference across the floor construction caused by stack effect decreases as the outdoor temperature increases. However, at around 21°C , the pressure difference caused by stack effect becomes smaller than the pressure difference caused by the imbalance in the ventilation system and therefore the sign of the pressure difference changes from positive to negative. When the pressure difference is negative there is no air leakage from the crawl space to the classroom and consequently no transport of contaminants.

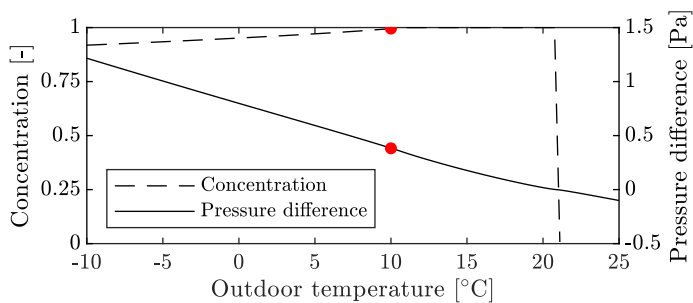

Figure 3.6: Concentration of contaminants in the classroom and pressure difference across the floor construction plotted against outdoor temperature. The temperature in the crawl space is 8°C and there is no wind.

In Figure 3.7 the temperature in the crawl space is increased from -5°C to 15°C . The concentration decreases slightly, and the pressure difference increases as the temperature in the crawl space increases.

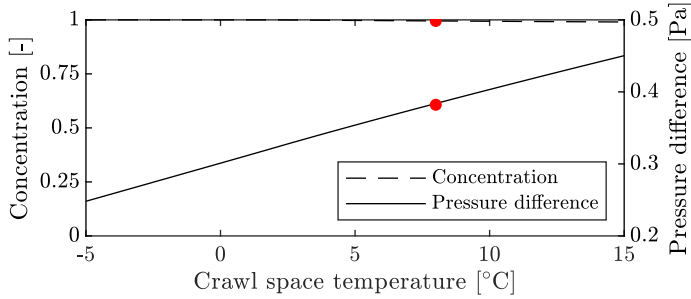

Figure 3.7: Concentration of contaminants in the classroom and pressure difference across the floor construction plotted against temperature in the crawl space. The outdoor temperature is 10°C and there is no wind.

In Figure 3.8, the wind velocity is increased from 0 to 10 m/s for wind blowing along the long side of the building. Both the concentration and the pressure difference decreases as the wind velocity increases. As the wind velocity increases above 5.5 m/s, the decrease in concentration becomes more rapid. The reason for this is that at lower wind velocities all of the air that leaks from the exterior and into the crawl space leaks out from the crawl space through the floor construction. However, at high enough wind velocity, some of the air that leaks from the exterior into the crawl space also leaks out from the crawl space to the exterior as shown, for example, in Figure 3.4.b. The sudden drop in concentration in the classroom is explained by a decrease in concentration in the crawl space caused by an increase in air change rate in the crawl space.

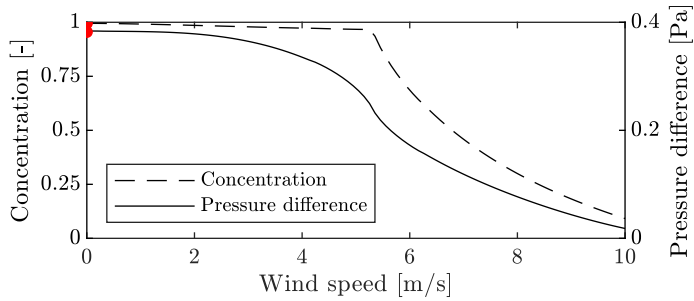

Figure 3.8: Concentration in the classroom and pressure difference across the floor construction plotted against wind speed when wind is blowing perpendicular to the long facades. The outdoor temperature is $10\text{ }^{\circ}\text{C}$ and the temperature in the crawl space is $8\text{ }^{\circ}\text{C}$.

In Figure 3.9, the wind velocity is increased from 0 to 10 m/s for wind blowing perpendicular to the long side of the building. Here, in contrast to Figure 3.8, the pressure difference across the floor construction increases as the wind increases. The decrease in concentration in the classroom is smaller compared to Figure 3.8.

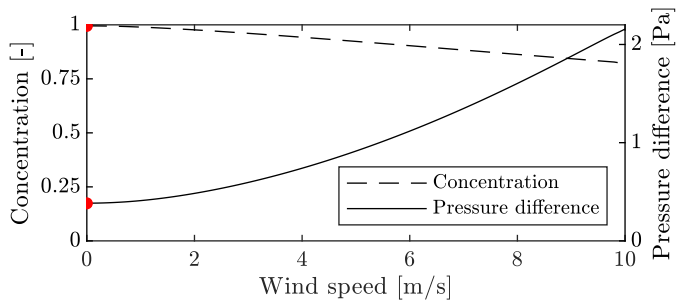

Figure 3.9: Concentration in the classroom and pressure difference across the floor construction plotted against wind speed when wind is blowing along the long facades. The outdoor temperature is $10\text{ }^{\circ}\text{C}$ and the temperature in the crawl space is $8\text{ }^{\circ}\text{C}$.

3.3.2 Case study of the impact from temperature, wind and leakage distribution

Simulated cases are compared to a reference case presented in Figure 3.10. All simulated cases have an indoor air temperature of 21°C. In the reference case, the building is simulated without wind and with an outdoor temperature of -20°C. To facilitate comparison with different cases, all presented concentrations are divided by the concentration in crawl space in the reference case. Consequently, the presented concentrations are unit-less and the concentration in the crawl space in the reference case is equal to 1.0. The results in Figure 3.10 are shown together with a profile of the pressure difference across the thermal envelope. Since there is no wind (in the reference case), the pressure difference across the floor constructions is caused by the imbalance in the ventilation system (higher exhaust airflow compared to the supply airflow) as well as the stack effect.

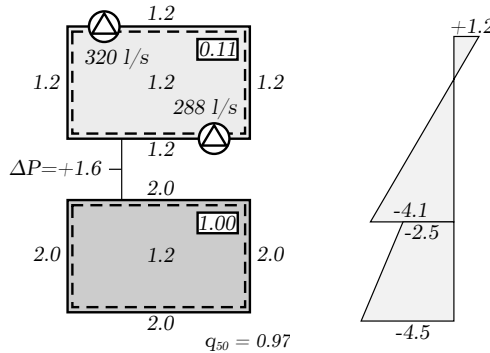

Figure 3.10: Simulation results for the reference case. The building is simulated without wind and with an outdoor temperature of -20°C. The concentration in the classroom is 11 % of the concentration in the crawl space.

Figure 3.11 shows simulation results for a weather case without wind and with an outdoor temperature of -20°C where the crawl space is more airtight compared to the reference case. Making the crawl space more airtight moves the

neutral pressure plane upwards and the pressure difference across the floor construction is reduced. The air change rate in the crawl space is lower compared to the reference case since the crawl space is more airtight and less air is leaking into the crawl space. The lower ventilation rate results in a higher concentration of contaminants in the crawl space.

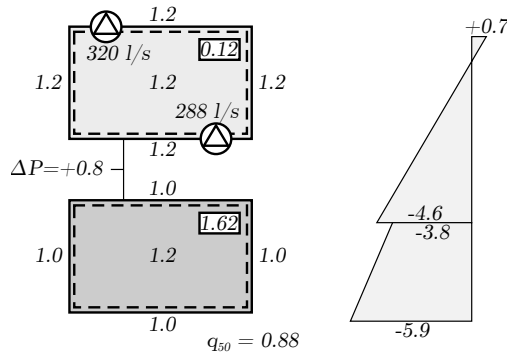

Figure 3.11: Simulation results for a case where the crawl space is more airtight compared to the reference case. The building is simulated without wind and with an outdoor temperature of -20°C .

In Figure 3.12 simulation results are shown for a weather case without wind and with an outdoor temperature of -20°C where the roof is made more airtight compared to the reference case. Here, the neutral pressure plane is located further down which results in a lower pressure difference across the floor construction compared to the reference case and consequently less contaminant transport from the crawl space. The more airtight roof also results in a lower air change rate in the classroom which should increase the concentration in the classroom. However, since the transport of contaminants is reduced, the total sum of these two effects means only a slight increase in contaminant concentration in the classroom.

with ventilation at normal rates before the concentration levels are reduced to a new steady state.

Figure 3.13 shows simulation results for a weather case without wind and with an outdoor temperature of -20°C where the mechanical ventilation is reduced to half of the ventilation in the reference case. The pressure difference across the floor construction is slightly lower compared to the reference case. However, since the air change rate in the classroom is lower, the concentration is higher.

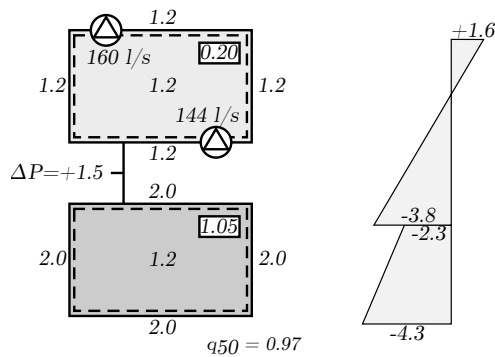

Figure 3.13: Simulation results for a case where the ventilation rates are half of the ventilation rates in the reference case. The building is simulated without wind and with an outdoor temperature of -20°C .

The above examples illustrate the complex relations between pressure distribution, air permeability distribution and concentration levels. Furthermore, these examples have a quite simplistic distribution of air permeability and the example only covers some possible cases. To cover a wider range of climate cases and a greater variation in air permeability, simulations are performed with the Monte Carlo method, described in the next section.

3.4 Monte Carlo simulation

Air permeability distribution in buildings varies depending on type of construction, detail design and craftsmanship. Many school buildings with indoor air quality problems has, in addition, undergone several renovations which increases the uncertainty of the air permeability distribution.

The Monte Carlo method is used to capture this uncertainty. In the Monte Carlo method, input data is described with probability density functions (PDF) rather than constant values. Simulations are repeated thousands of times and the result is a database with thousands of buildings with simulated concentrations for different climate cases. The database can be analyzed, and for example PDF's of concentration levels in the classroom and pressure difference across the floor construction can be calculated.

Unfortunately, there is limited information on how the air permeability is distributed within a building. However, one French database [19] and one US database [10] is available with measurements of overall airtightness. In both the above mentioned databases, the distribution of air permeability resembles a Weibull distribution. It is therefore assumed that the Weibull distribution applies also for the air permeability distribution within a building and the PDF in Figure 3.14 is used when assigning values for air permeability to different building parts in the simulation.

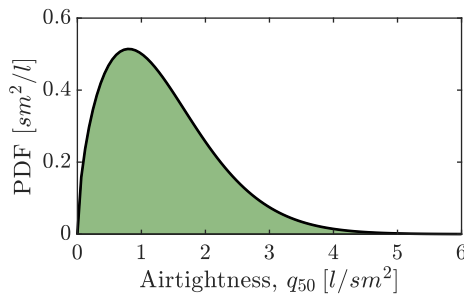

Figure 3.14: Probability density function (PDF) used for choosing airtightness for building parts in the Monte Carlo simulation.

The steps in the Monte Carlo simulations are summarised in Figure 3.15. In the first step, airtightness is provided based on the PDF (Figure 3.14). Corresponding values for the airflow coefficient, C in Equation 2.1 is assigned to the roof, the floor, each wall in the crawl space and each wall (three for each wall) in the classroom.

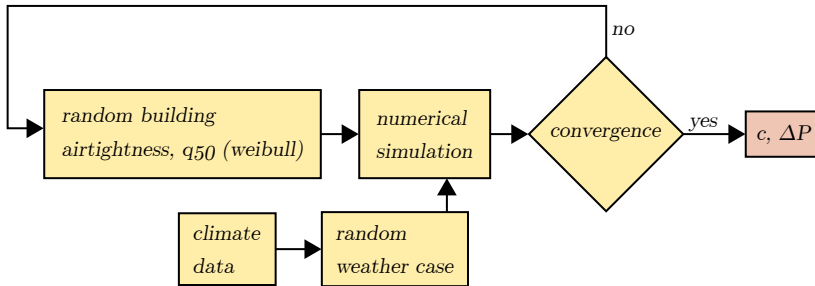

Figure 3.15: Flowchart showing the calculation steps in the Monte Carlo simulation used to obtain the contaminant concentration in the classroom and the pressure difference across the floor construction.

For a more thorough description of the Monte Carlo method and the convergence criteria used in the simulation see Paper II.

Several simulations have been performed with the Monte Carlo simulation. Two different building shapes, two geographical locations, different shielding conditions and building orientations are simulated, see Paper II for a more comprehensive description.

Pearson's linear correlation coefficient, r , is a measure of the linearity of the relationship between two variables. A value of $r=1$ means a perfectly linear relationship and a value of $r=0$ means that there is no linear relationship.

Pearson's correlation coefficient is used to investigate correlations between input parameters and output parameters (such as concentration in the classroom and pressure difference across the floor construction).

Figure 3.16 is an example of the results from a Monte Carlo simulation on a

long shaped building in Gothenburg climate.

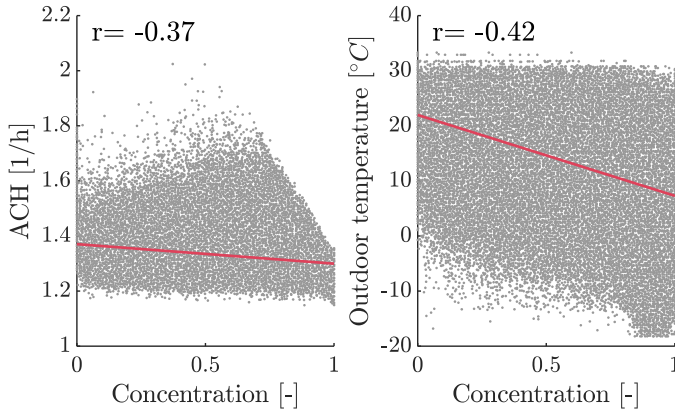

Figure 3.16: Air change rate per hour and outdoor temperature plotted against normalized concentration in the classroom for Monte Carlo simulations on a long shaped building in Gothenburg climate with building orientation 90° and exposed shielding condition. The red line is the least-squares line for the data points. Each plot also shows the Pearson's correlation coefficient in the upper left corner.

Table 3.2 shows a summary of the Pearson's correlation coefficients calculated for a long shaped building situated in Gothenburg. Highlighted cells have higher Pearson's correlation coefficients than the cells that are not highlighted.

Table 3.2: Pearson's linear correlation coefficients for simulations with a long shaped building situated in Gothenburg. A positive pressure difference across the floor construction means that air is leaking from the crawl space to the classroom.

	Concentration (classroom)	ΔP across the floor
Concentration (classroom)	1	0.05
ΔP across the floor	0.05	1
Outdoor temperature	-0.37	-0.43
Wind speed	-0.18	0.11
ACH in the classroom	-0.34	-0.08
q₅₀ classroom	-0.07	-0.01
q₅₀ floor	0.07	-0.54
q₅₀ roof	-0.07	0.04
q₅₀ crawl space walls	-0.06	0.16
q₅₀ classroom walls	-0.07	-0.04

Table 3.2 shows that for the concentration level in the classroom, outdoor temperature, wind speed and air change rate in the classroom are the most important parameters. For the pressure difference across the floor construction, outdoor temperature and airtightness of the floor construction are the most important parameters. Increased wind results in a higher air change rate in the classroom. Lower outdoor temperatures (higher stack effect) increases the air change rate of the building and increases at the same time the transport of contaminants from the crawlspace to the classroom since the pressure difference across the floor construction increases. However, the dilution of contaminants caused by the increased air change rate is of higher importance than the increased inflow of contaminants from the crawl space if the inflow of contaminants does not reach its maximum as illustrated in Figure 3.6.

The highest concentration in the classroom is reached when there is little wind and mild outdoor temperature. In this scenario, the only driving force for the air

leakage from the crawl space to the classroom is the pressure difference caused by the imbalanced mechanical ventilation. This particular case will have the lowest air change rate and at the same time the highest flow of contaminants from the crawl space to the classroom, see Figure 3.4.a. However, the correlation coefficient suggests that increasing the outdoor temperature reduces the concentration in the classroom, which is true for weather cases with wind (there is wind in most of the weather cases in the weather data). At higher wind speeds the crawl space becomes more ventilated because of a higher pressure difference across the crawl space, which reduces the flow of contaminants up to the classroom. As the outdoor temperature decreases, when there is wind, the pressure difference across the floor construction and consequently the air leakage and contaminant flow up to the classroom increases, which may lead to increased concentrations in the classroom.

To sum up, the highest concentration in the classroom occurs during mild and calm weather. The concentration decreases as the wind increases if the outdoor temperature is still mild. For a windy day (if wind speeds are high enough), the concentration in the classroom increases as the outdoor temperature decreases.

It is important to note that high concentrations in the classroom may also occur during certain combinations of low outdoor temperature and high wind speeds, dependent on building orientation and air permeability distribution.

3.4.1 Exhaust fan in the crawl space

Different measures can be taken to prevent contaminants from reaching the classroom or to reduce the concentration of contaminants in the classroom. One common measure is to install an exhaust fan in the crawl space with the purpose of reversing the sign of the pressure difference to negative, so that there is no air leakage from the crawl space to the classroom. It is common praxis in Sweden to adjust the airflow of the exhaust fan to achieve a negative pressure difference of -5 Pa. Monte Carlo simulations are used to test the sensitivity of such an arrangement. In some cases, there are ventilation openings in the

crawl space that are sealed when installing the exhaust fan. This example illustrates what could happen if one or two of these sealed ventilation openings break, something which was observed in one investigated school building. Figure 3.17 shows the probability distribution for the pressure difference across the floor construction when one and two additional openings are added to the crawl space walls after the exhaust fan has been installed.

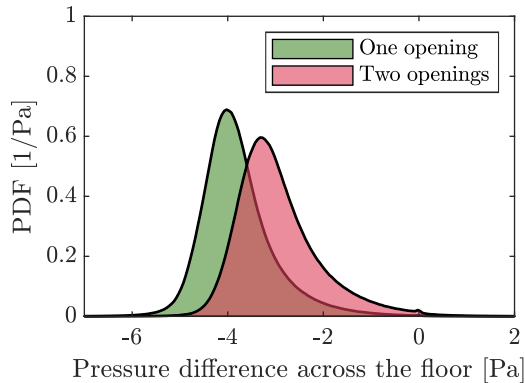

Figure 3.17: Results from simulations with an exhaust fan in the crawl space where one and two additional openings are made in the walls of the crawl space.

In the simulation each building is simulated twice. First, the exhaust airflow of the fan in the crawl space is adjusted to achieve a pressure difference across the floor construction of -5 Pa. In the second step one or two openings are added to the crawl space and the building is simulated again to get the pressure difference across the floor construction shown in Figure 3.17.

3.4.2 Increased mechanical ventilation in the classroom

Another common measure is to increase the ventilation rate of the classroom to reduce the concentration levels. However, if the pressure difference across the floor construction is increased when the ventilation rate is increased it is not certain that the concentration level in the classroom is reduced. Monte Carlo

simulations are performed where the exhaust airflow in the mechanical ventilation system is increased with 10 l/s. Results show that for a long shaped building in Gothenburg climate, the concentration in the classroom is increased in 17% of the simulated cases. For a long shaped building in Östersund climate, the concentration increased in 24% of the simulated cases. The increase in concentration can be explained by an increase in contaminants that leaks into the classroom. In most of the cases, all contaminants produced in the crawl space reaches the classroom. For a scenario where not all of the contaminants enters the classroom, increasing the exhaust ventilation in the classroom will lead to a higher pressure difference across the floor construction and, consequently, a larger share of the contaminants produced in the crawl space will reach the classroom. If instead, the exhaust air flow is increased when all of the contaminants produced in the crawl space already enters the classroom, the increased exhaust airflow will only increase the air change rate in the classroom without increasing the flow of contaminant from the crawl space, since this is already at maximum.

Figure 3.18 shows the normalized concentration in the classroom and the normalized contaminant flow from the crawl space plotted against exhaust ventilation for one building. Normalized flow of contaminants is calculated as flow of contaminants divided by source strength. In this example, the flow of contaminants reaches maximum at around 340 l/s, after that increased ventilation will not draw more contaminants into the classroom and the concentration starts to decrease.

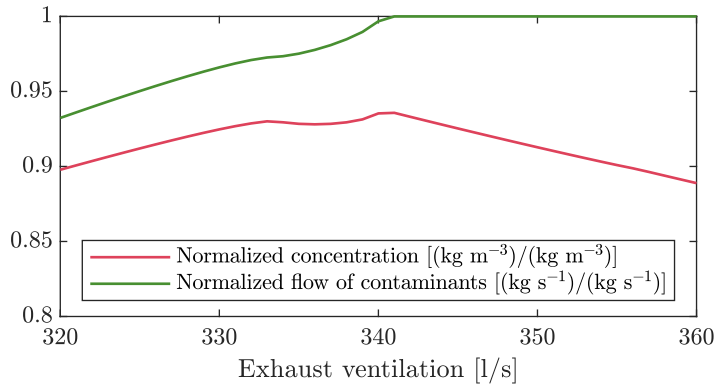

Figure 3.18: Contaminant flow through the floor construction and concentration of contaminants in the classroom plotted against increased mechanical exhaust airflow from the classroom.

Chapter 4

Measurements of pressure difference

Measurements of wind speed, wind direction, outdoor temperature and pressure difference across the floor construction has been conducted in a school building with crawl space and with indoor air quality problems. The school has undergone several renovations to try to improve the indoor air quality. However, the renovations have not been successful, and the school now awaits deconstruction. In an investigation it was concluded that the poor indoor air quality was mainly caused by contaminants coming from the crawl space and that one of the contaminants was coming from emissions from wood preservatives. The school is situated in Gothenburg, on the west coast of Sweden.

Wind and temperature was measured with a weather station, LeWL Windlogger, placed on a pole on the roof of the building shown in Figure 4.1. The weather station has logger capabilities and stores average values on an hourly basis. The pressure difference across the floor construction is measured using DG-700 Pressure & Flow Gauge connected to a computer. The setup is similar to [20]. The building has an imbalanced ventilation system and two exhaust

fans installed in the crawl space. Figure 4.2 and Figure 4.3 shows measurement results from two different periods; 1st of January to 20th of March and 25th of March to 30th of April respectively.

In the second measurement period (25th of March to 30th of April) an additional opening was found in the crawl space, that was not there during the first measurement period. The additional opening was first discovered when analysing the measurement data using a numerical regression method, described in Paper II. Interestingly, the consequence of the additional opening is a greater variation in pressure difference across the floor construction and the sign of the pressure is positive (higher pressure in the crawl space compared to the classroom) during a larger share of the time during the second measurement period compared to the first measurement period, similar to the results from the numerical simulations shown in Figure 3.17.

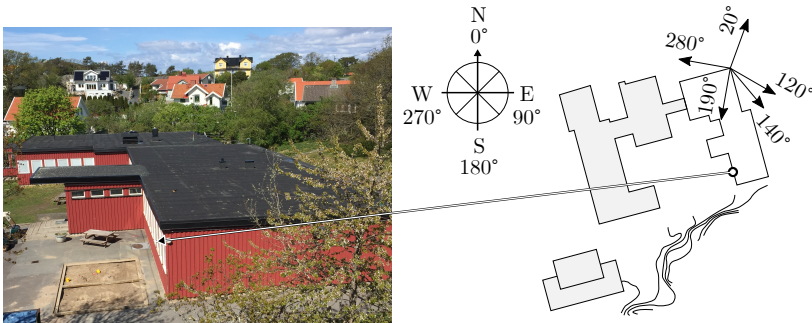

Figure 4.1: Photograph and principle drawing of the school. The gray areas in the drawing are parts of the building that were still in use during the measurements and the white area is the building in which the measurements were performed. The curved lines at the bottom of the drawing marks a hill. The arrows with noted wind directions show the most common wind directions.

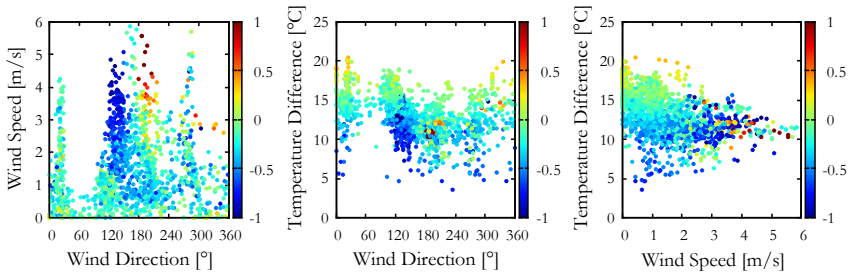

Figure 4.2: Measurements of wind speed, wind direction and temperature difference between indoor and outdoor plotted together with measurements of pressure difference (in pascal) across the floor construction for 1st of January to 20th of March. The colors (blue to red) show the pressure difference across the floor.

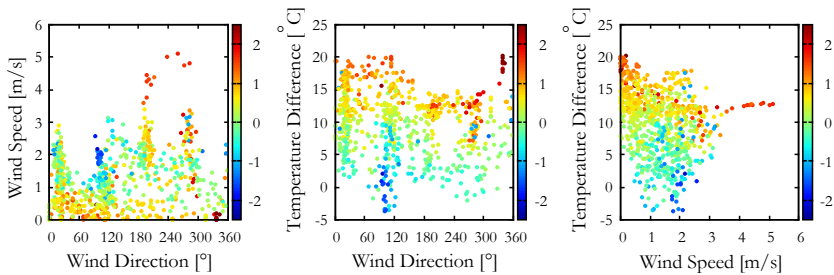

Figure 4.3: Measurements of wind speed, wind direction and temperature difference between indoor and outdoor plotted together with measurements of pressure difference (in pascal) across the floor construction for 25th of March to 30th of April. The colors (blue to red) show the pressure difference across the floor.

In both measurement periods it becomes clear that the temperature difference is important for the pressure difference across the floor construction. As it gets colder outdoors, the temperature difference between indoor and outdoor increases, and the pressure difference across the floor construction increases. This behavior is also seen in numerical simulations, for example in Table 3.2 or in the case study in Paper II.

Results also show that the shape of the building and the surrounding terrain affect how increased wind speed affects the pressure difference across the floor construction. For wind direction 120° - 140° the pressure difference across the floor construction is mostly negative. Looking at Figure 5.3, this is the wind angle which is blocked partly by the hill and the effect from the wind is therefore reduced. Unlike the numerical simulations, the school building has a more complex shape and surrounding obstacles are not distributed evenly around the building.

Chapter 5

Measurements of leakage paths

Knowing where in the construction leakages occur is essential for learning how to avoid air leakage in future constructions and if measures are to be taken to make the construction more airtight.

There are several methods available for finding leakages in a building. Some examples are tracer gas, smoke, thermography, and acoustic methods. It is important to be able to determine whether the air leakage is coming from the crawl space or from elsewhere. A method where dry ice (frozen carbon dioxide) is used as a tracer gas is therefore tested.

5.1 Icebox method

In this project, carbon dioxide is used as a tracer gas. The advantage of carbon dioxide is that it does not easily react with other gases and materials and that it has a density similar to that of air, which facilitates the mixing of carbon dioxide with air. Also, measuring devices for carbon dioxide are plentiful on the market

and are often less expensive compared to measurement devices for other tracer gases.

One drawback with using carbon dioxide as a tracer gas is that it is present in the atmosphere (about 400 ppm) and it is released in the process of cellular breathing in plants and animals, humans included. It is therefore a risk that people present during measurement interferes with the results. However, for detecting air leakage origin, it is not important that the exact undisturbed concentrations are measured. It is enough to measure clear peaks in concentrations that are not caused by for example people present during the measurement.

In the proposed method, dry ice (frozen carbon dioxide) is used as a source for carbon dioxide. At atmospheric pressure, dry ice sublimates at $-78.5\text{ }^{\circ}\text{C}$ and must therefore be handled carefully to avoid frost damages. The rate of sublimation depends on the heat absorbed and is determined mainly by the temperature of the surrounding air. Some common uses for dry ice are food preserving and blast cleaning. Dry ice is easily obtained and is usually delivered as pellets.

The dry ice pellets are put in an insulated box, see Figure 5.1 and Figure 5.2, together with an electrical heater. The purpose of the heater is to increase the rate of sublimation. A similar setup has been used previously by [21] to estimate air flow rates in a multi-story office building.

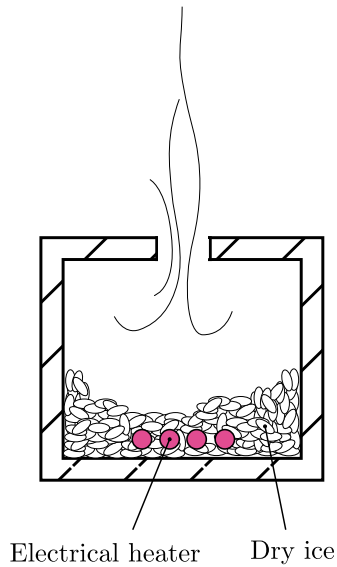

Figure 5.1: Principal drawing of the "icebox" setup.

In the first experiments with the icebox, a fan was installed in the lid of the box with the purpose of stabilizing the rate of sublimation. However, ice was forming on the blades of the fan which reduced the airflow. It was found that two openings in the lid together with the pressure caused as the ice sublimates is enough to create a steady flow of carbon dioxide out from the box. Different methods for controlling the sublimation rates and distribution of carbon dioxide have been tested, the reader is referred to Paper II for a more thorough description.

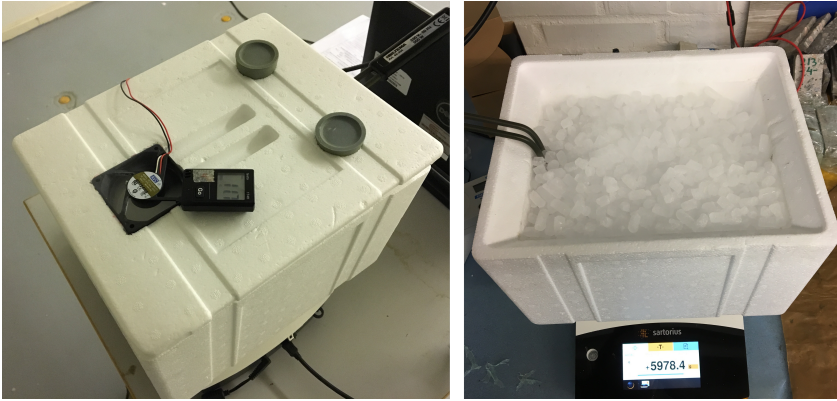

Figure 5.2: Photo (left) of the icebox with a fan installed in the lid. It was later found that the performance of the icebox improved when the fan was removed. Photo (right) of the icebox without the lid and filled with dry ice.

If contaminants are suspected to come from the crawl space (or any other space next to the occupant space) a first step is to find out if there are openings or cracks in the construction between the crawl space and the classroom in which contaminants can be transported. This can be done by traditional methods such as thermal imaging, smoke or air velocity measurements combined with blower door depressurization. In this project, thermal imaging was the preferred choice since it is usually faster than other available methods, mainly since the leakage search can be performed from the center of the room. While if doing, for example, leakage search by measuring air velocity or smoke, measurements needs to be done close to the wall. The drawback with thermal imaging is that the method is restricted to chilly days when cold air is leaking into the building.

Once air leakages that are suspected to originate from the crawl space have been identified the next step in the method can be initiated. Carbon dioxide measuring devices, preferably with logging capabilities are placed in the classroom close to the identified leakages. Carbon dioxide is then released in the crawl space using the icebox close to the positions where air leakages have

been found in the previous step. Fans should be placed adjacent to the icebox to improve mixing of air and carbon dioxide in the crawl space. A pressure difference across the floor construction during the measurements is achieved with a blower door. The blower door can be placed either in the hatch to the crawl space or at the entrance to the building. If placed in the hatch to the crawl space it is used to pressurize the crawl space and if placed at the entrance it is used to depressurize the classroom.

The method proposed in this project can be summarized in the following steps (quoted from Paper II):

1. Use blower door to either pressurize the crawl space or depressurize the indoor space.
2. Perform a leakage search to find leakages in the construction. This can for instance be done using a thermal camera.
3. Measure carbon dioxide background concentration prior to starting the carbon dioxide production in the crawlspace.
4. Add carbon dioxide to the crawl space, for instance by using the icebox method presented earlier in this paper.
5. Measure carbon dioxide concentration at locations that in step 1 proved to have air leakage.
6. Locations with carbon dioxide levels high above carbon dioxide background concentrations will have air coming from the crawl space.

Each test step is preferably performed until steady-state conditions are reached, and at least for 15 minutes.

5.1.1 In situ test

The method described above is tested on the school building described in Chapter 4. For a more complete description of the in situ test the reader is referred to Paper II. A leakage search was performed using thermal imaging while the

classroom was depressurized using a blower door. The identified leakages are denoted L1 to L4 in Figure 5.3.

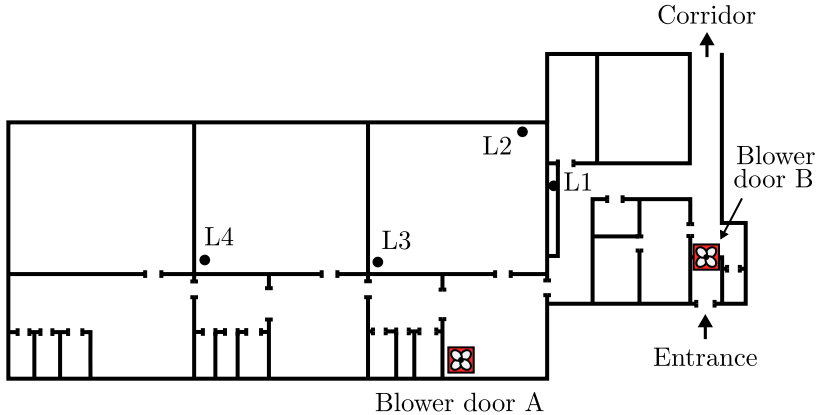

Figure 5.3: Floor plan of the school. L1 to L4 denotes the air leakages found during the leakage search.

A pressure difference across the floor construction was created using a blower door. Two different positions of the blower door was tested (A and B); in the hatch down to the crawl space and in the main entrance to the building, see Figure 5.3.

Results from measurement of carbon dioxide can be seen in Figure 5.4 and Figure 5.5. Figure 5.4 shows the carbon dioxide concentrations when the blower door is placed in the hatch to the crawl space, *blower door A* in Figure 5.3. Results show that the carbon dioxide concentration increases both at L1 and L4 (see also Figure 5.6 and 5.7) which indicate that these two leakages are connected to the crawl space.

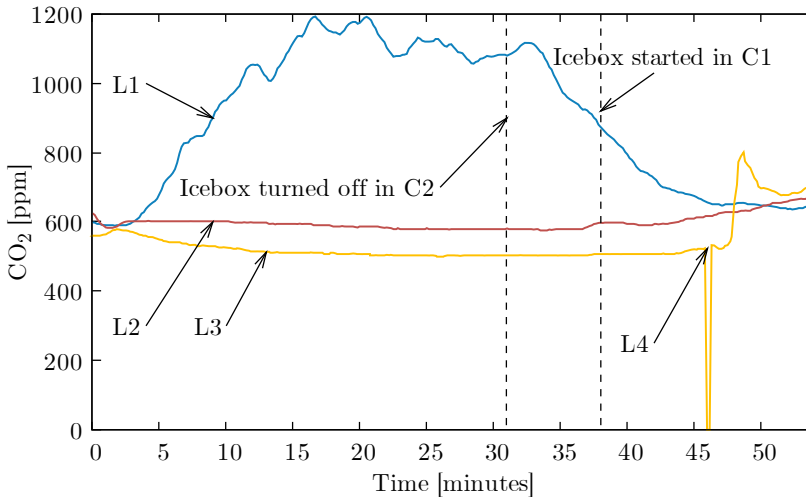

Figure 5.4: Results from measurements of carbon dioxide when the blower door is placed in the hatch to the crawl space, location A. C1 is the location of the icebox in the crawl space close to L3. C2 is the location of the icebox in the crawl space close to L1.

Figure 5.5 shows the concentrations when the blower door is placed in the entrance, *blower door B* in Figure 5.3. An increase in concentration can be seen at L1 also in this case. However, there is also an increase in concentration at L2 which was not seen when the blower door was placed in the hatch. Similarly, the increase in concentration at L4 that was seen when the blower door was placed in the hatch is no longer present. One explanation for this can be that the leakage path inside the construction is affected by the relations in pressure between indoor, outdoor and the crawl space. This can be caused by, for example, moving foils or sheets.

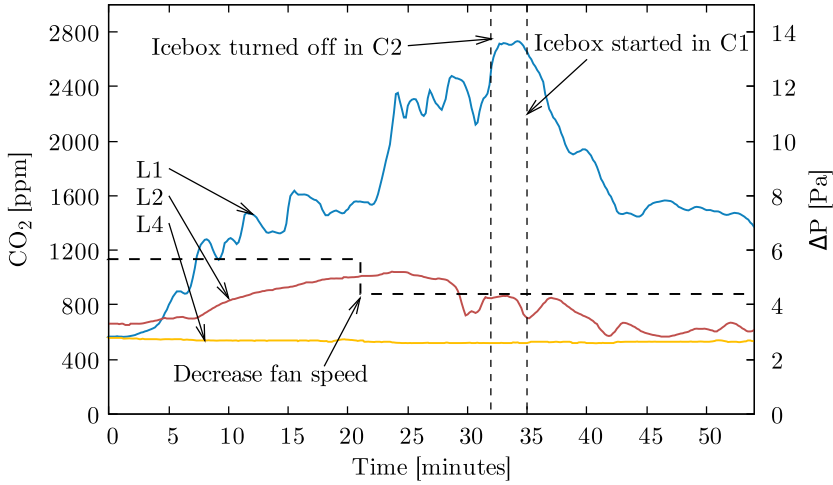

Figure 5.5: Results from measurements of carbon dioxide when the blower door is placed in the entrance to the school building, location B. C1 is the location of the icebox in the crawl space close to L3. C2 is the location of the icebox in the crawl space close to L1.



Figure 5.6: To the left is a photograph and to the right is a thermography of air leakage location L1. The air is leaking through a penetration through the floor construction in which electrical wires are installed.



Figure 5.7: To the left is a photograph and to the right is a thermography of air leakage location L4. The air is leaking through cracks in the connection of the door frame to the inner wall and floor.

Chapter 6

Conclusions and discussion

The focus in this project has been on school buildings with indoor air quality problems where the contaminant source is situated in the crawl space. The aim was to investigate how the pressure distribution and contaminant transport is affected by air permeability distribution, building shape, building orientation and weather (temperature and wind).

Numerical simulations show that for school buildings with an imbalanced ventilation system, where the exhaust airflow is larger than the supply airflow, the pressure difference across the floor construction is positive (so that air leaks from the crawl space to the classroom) for most weather situations and building configurations.

The numerical simulations also suggest that in most situations, most of the air that enters the crawl space also leaks into the classroom. This means that most of the contaminants produced in the crawl space also reaches the classroom.

Icebox method

Using carbon dioxide as dry ice with the described icebox method is an easy and cheap method for determining whether air leakage is coming from the crawl space or from elsewhere. However, the placement of the blower door, can affect the results and it is therefore advisable to perform the measurements with the blower door placed in at least two separate locations.

Factors influencing the pressure difference across the floor

Both simulations and measurements show the importance of stack effect on the pressure difference across the floor construction. As the outdoor temperature drops, the pressure difference across the floor construction increases with an increased air leakage from the crawl space to the classroom as a result.

The wind is also an important factor for the pressure difference across the floor construction. In general, increased wind velocity means a higher positive pressure. Wind direction in relation to building orientation, air permeability distribution and building shape is also important. In some cases, the pressure difference becomes more negative as the wind velocity increases. For example, wind blowing parallel to long facades cause a higher pressure difference across the floor compared to wind blowing perpendicular to the long facades (which sometimes cause a negative pressure difference). The effect is enhanced if the long facades are leakier compared to the rest of the building. In the measurements, the pressure difference ranged from -2 Pa to +2 Pa depending on the wind direction.

Ventilation rates and contaminant concentration

The pressure difference across the floor construction is a good indicator for the direction of the air leakage but there is no clear relation between the contaminant concentrations in the classroom and the pressure difference across the floor construction

Measurements with the icebox method show that increasing the pressure difference across the floor construction by increasing airflow through the blower

door does not increase the concentrations of carbon dioxide at the leakage sites.

A similar effect can be seen in the numerical simulations where increased wind speed or increased stack effect results in both increased ventilation rate in the classroom and increased pressure difference across the floor construction but not necessarily increased concentrations in the classroom.

Simulations show that as wind speeds increase, the air change rate in the classroom increases which, in most cases, results in decreasing the concentrations of contaminants in the classroom.

The most critical situation, in terms of high contaminant concentration in the classroom, for a school with imbalanced ventilation, is during calm and mild days.

If increasing the exhaust airflow in the mechanical ventilation in the classroom as an attempt to reduce the concentration levels in the classroom, simulations show that concentrations instead increases in 17 % of the cases in Gothenburg climate and 24 % of the cases in Östersund climate. It is therefore important to measure the pressure difference across the floor construction when increasing the mechanical ventilation to make sure that the pressure difference does not increase.

Exhaust fan in the crawl space

Numerical simulations show that an exhaust fan in the crawl space can be a good way of reversing the pressure difference across the floor construction so that air is leaking from the classroom down to the crawl space rather than from the crawl space up to the classroom.

It is recommended to adjust the exhaust airflow so that a pressure difference of at least -5 Pa is achieved across the floor construction. However, there can be unfortunate circumstances in which -5 Pa is not enough.

With an exhaust fan in the crawl space it is important that the airtightness of the crawl space is sustained. If the crawl space becomes leakier, for example

if sealed ventilation openings are broken (as in one of the studied schools), this can be enough to change the sign of the pressure difference to positive.

Discussion and practical recommendations

If possible, increasing the mechanical ventilation rates in the classroom can be an easy and quick way to improve the indoor air quality. However, it is important to measure the pressure difference across the floor construction before and after the increase in mechanical ventilation rate. The pressure difference across the floor should not become more positive since this might increase the concentration of contaminants in the classroom.

The exhaust fan in the crawl space is a measure that should, if working as intended, prevent all transport of contaminants from the crawl space to the classroom. Making the crawl space airtight before installing the fan is advisable since the crawl space can be depressurized at lower fan speeds. However, since the pressure difference in a more airtight crawl space is more sensitive to changes in both airtightness and fan speed it is important that the airtightness of the crawl space is maintained and that the exhaust fan is working at the intended fan speed.

Monitoring the pressure difference across the floor construction is advisable. The pressure difference varies throughout the year dependent on weather. It is a good idea to also keep track of the weather and to note down at what wind speeds, wind directions and outdoor temperatures there is significant changes in pressure difference. This way it is easier to determine if future changes in pressure difference is caused by for example a malfunction in the exhaust fan, cold outdoor temperature, or wind.

Adjusting the exhaust fan in the crawl space to achieve a pressure difference of -5 Pa might work in most cases, but not necessarily in all cases. Monitoring the pressure difference, with extra care during the first one or two years, is a good idea to ensure that the target pressure of -5 Pa is good enough for that particular

school building and if not, adjust the fan speed accordingly. To be even more on the safe side, adjusting the fan speed during chilly days is a good idea since this is likely the weather in which the pressure difference is highest.

References

- [1] N. Matson and M. Sherman. “Why we ventilate our houses - An historical look”. In: *Lawrence Berkeley National Laboratory* (2004).
- [2] I. Annesi-Maesano et al. “Indoor air quality and sources in schools and related health effects”. In: *Journal of Toxicology and Environmental Health, Part B* 16.8 (2013). Publisher: Taylor & Francis, pp. 491–550. ISSN: 1093-7404.
- [3] C-G. Bornehag et al. “Phthalates in Indoor Dust and Their Association with Building Characteristics”. In: *Environmental Health Perspectives* 113.10 (Oct. 2005), pp. 1399–1404. DOI: 10.1289/ehp.7809.
- [4] G-H. Cai et al. “Fungal DNA and pet allergen levels in Swedish day care centers and associations with building characteristics”. en. In: *Journal of Environmental Monitoring* 13.7 (2011), pp. 2018–2024. DOI: 10.1039/C0EM00553C.
- [5] M. Täubel et al. “Co-occurrence of toxic bacterial and fungal secondary metabolites in moisture-damaged indoor environments”. In: *Indoor air* 21.5 (2011), pp. 368–375.
- [6] M. Airaksinen et al. “Microbial contamination of indoor air due to leakages from crawl space: a field study”. eng. In: *Indoor Air* 14.1 (Feb. 2004), pp. 55–64. ISSN: 0905-6947.
- [7] R. Hilling. *220 skolor. Skador och fel i skolbyggnader. [220 schools. Damage and defects in school buildings.]* Tech. rep. 1998:34. Brandmotstånd, 1998, p. 186.

- [8] *SWESIAQ-modellen*. sv. Tech. rep. SWESIAQ, p. 42. URL: www.swesiaq.se (visited on 06/15/2020).
- [9] *ASHRAE handbook : Fundamentals : SI edition*. ASHRAE, 2017, ©2017, 2017. ISBN: 9781939200587.
- [10] W. Chan, I. Joh, and M. n. *Analysis of Air Leakage Measurements from Residential Diagnostics Database*. en. LBNL-5967E, 1163524. Aug. 2012, LBNL-5967E, 1163524. DOI: 10.2172/1163524.
- [11] W. S. Dols and B. J. Polidoro. *CONTAM User Guide and Program Documentation Version 3.2*. en. Tech. rep. NIST TN 1887. National Institute of Standards and Technology, 2015, NIST TN 1887. DOI: 10.6028/NIST.TN.1887. URL: <https://nvlpubs.nist.gov/nistpubs/TechnicalNotes/NIST.TN.1887.pdf> (visited on 01/13/2020).
- [12] Carl-Eric Hagentoft. *Introduction to building physics*. Studentlitteratur, 2001. ISBN: 9789144018966.
- [13] M. Orme, M. W. Liddament, and A. Wilson. *Numerical Data for Air Infiltration and Natural Ventilation Calculations*. en. AIVC, Coventry, UK, 1994, p. 100. ISBN: 1946075972.
- [14] Fredrik Domhagen and Paula Wahlgren. “Air leakage variations due to changes in moisture content in wooden construction-magnitudes and consequences”. In: *38th AIVC Conference "Ventilating healthy low-energy buildings"*. 2017.
- [15] H. E. Feustel and A. Raynor-Hoosen. *Fundamentals of the multizone air flow model - COMIS*. en. AIVC, Coventry, UK, 1990. ISBN: 0946075441.
- [16] F. Haghghat and A. C. Megri. “A Comprehensive Validation of Two Air-flow Models — COMIS and CONTAM”. en. In: *Indoor Air 6.4* (1996), pp. 278–288. ISSN: 1600-0668. DOI: 10.1111/j.1600-0668.1996.00007.x.
- [17] P. Warren. “Multizone Air Flow Modelling (COMIS): Technical Synthesis Report”. In: *IEA ECBCS Annex 23.06* (2000), p. 2000.
- [18] C-E. Hagentoft. “An analytical model for crawlspace temperatures and heat flows: steady-state, periodic and step-response components”. In: *Re-*

- port TVBH* 3012 (1986). Publisher: Byggnadsfysik LTH, Lunds Tekniska Högskola. ISSN: 0349-4950.
- [19] B. Moujalled, V. Leprince, and A. Bailly Mélois. “French database of building airtightness, statistical analyses of about 215,000 measurements: impacts of buildings characteristics and seasonal variations”. en. In: *39th AIVC Conference "Smart Ventilation for Buildings"*. AIVC, 2018.
- [20] S. Solcher, S. Rolfsmeier, and P. Simons. “Natural Pressure Differential – Infiltration Through Wind Results of a Long-Term Measurement”. In: *38th AIVC Conference "Ventilating healthy low-energy buildings"*. Nottingham, UK, 2017.
- [21] H. Konder and T. Bednar. “Estimation of air flow rates in large buildings based on measurements”. In: *Nordic Symposium on Building Physics Copenhagen*. 2008.

Part II

Appended papers

