



A framework to assess and repair pre-fatigued welded steel structures by TIG dressing

Downloaded from: <https://research.chalmers.se>, 2026-04-04 12:45 UTC

Citation for the original published paper (version of record):

Manai, A. (2020). A framework to assess and repair pre-fatigued welded steel structures by TIG dressing. *Engineering Failure Analysis*, 118. <http://dx.doi.org/10.1016/j.engfailanal.2020.104923>

N.B. When citing this work, cite the original published paper.



A framework to assess and repair pre-fatigued welded steel structures by TIG dressing

Asma Manai

Chalmers University of Technology, Department of Architect and Civil Engineering, 41296 Gothenburg, Sweden



ARTICLE INFO

Keywords:

Repair of welded joints
Fatigue
TIG dressing
Pre-fatigued structures
Residual stress

ABSTRACT

The extension of fatigue life of ageing welded steel structures is an important challenge faced by the industry. Herein, a detailed framework was developed to **assess** and **improve the performance** of these aged structures (pre-fatigued) using tungsten inert gas (TIG) dressing. Within this framework, relevant damage theories and models were applied to assess the state of pre-fatigued structures. Based on the results of this assessment and TIG dressing parameters, the extended fatigue life was estimated. Particular attention is paid to the deterministic study of the TIG dressing parameters, which are the fusion depth, weld toe radius, and residual stress. The resulting data, especially longitudinal and transversal attachments, were analysed to verify the proposed framework. The improved fatigue life was found to be at least 3.4 times the as-welded fatigue life when the cracks were completely re-melted. A significant dependency of the extended fatigue life on the remaining crack length after treatment was observed. A comparison of my predictions with experimentally obtained fatigue lives in other studies showed an absolute error of 20%.

1. Introduction

The last decades of the 20th century witnessed an increase in the construction of steel bridges. Currently, a significant proportion of these bridges are ageing and operating beyond their design fatigue life. However, the simultaneous replacement of these structures is a major technical and constructional challenge. Strengthening these existing structures prolongs their fatigue life without the requirement to replace them.

Extensive research has been performed to develop guidelines and frameworks to predict the remaining fatigue life of ageing bridges [1–3]. Aeran *et al.* [4] presented a detailed framework for fatigue assessment of steel-based offshore structures, which can also be extended to other steel structures. They focussed on recognising the state of an aged structure via detailed investigations of the loading effects and structural material information. In their framework, they characterised the state of the pre-fatigued structures and predicted their remaining fatigue life without indicating any suitable treatment or fatigue life after treatment. In 2008, Kühn *et al.* [5] reported a detailed guideline for the evaluation of the remaining fatigue life of aged steel bridges within the European Convention Construction Steelwork (ECCS). This work is bounded to the preliminary assessment steps of the state of pre-fatigued bridges without providing any indication of the recommended models for damage calculations and crack propagation. Kühn [6] summarised this report with an astute guideline for the estimation of the remaining fatigue life.

These studies ([1–7]) provide a general assessment technique for existing steel structures without recommending models for damage calculations and crack propagation, which is required for an accurate prediction of the remaining fatigue life. Note that these studies did not provide any specific recommendations or suitable treatments to improve welded steel structures.

E-mail address: asma.manai@chalmers.se.

<https://doi.org/10.1016/j.engfailanal.2020.104923>

Received 6 March 2020; Received in revised form 5 August 2020; Accepted 11 September 2020

Available online 18 September 2020

1350-6307/ © 2020 The Author. Published by Elsevier Ltd.

Nomenclature			
		RS_{AW}	Residual stress from welding
		a_0	Size of the introduced crack in the pre-fatigued phase
TIG	Tungsten inert gas	f_y	Yield stress of the material
N_{pre}	Number of load cycles applied in the pre-fatigued phase	σ_{ar}	Applied stress amplitude with zero mean stress
RS	Residual stress	N_{ci}	Number of cycles to crack initiation
RS_{TIG}	TIG dressing residual stress	D	Damage
a_{TIG}	TIG penetration depth (fusion depth)	N_{ext}	Extended fatigue life after TIG treatment
R_{TIG}	Radius of the weld toe after TIG treatment	N_{fAW}	Fatigue life of the as-welded structure
R_{AW}	Radius of the weld toe of the as-welded state		

Therefore, more detailed guidelines, particularly for repairing welded steel structures, are required. The integration of relevant theories and models that can accurately capture the state of pre-fatigued structures and post-weld treatment parameters to predict improvement in fatigue life is critical. Recommendations that can estimate the damage distribution in the absence of cracks and provide the parameters of post-weld treatment techniques are also necessary.

Welding of metals was introduced more than a century ago to replace joints with bolts. Welding is a process associated with intensive heating which leads to considerable changes in local microstructure of the material and the formation of high welding residual stresses (RS) in the welded joint. RS introduces a change in the stress ratio, which denotes a change in the characteristic of cyclic loading, which can detrimentally affect the fatigue strength of welded joints. Cui *et al.* [8] found that the fatigue life is overestimated by 49% by neglecting weld RS and its relaxation. Li *et al.* [9] showed that fatigue resistance of welded joints is strongly dependent on the failure mode, and the dominant failure modes are important to predict the fatigue life of welded joints. These results were supported by [10] and [11].

For welded components, serious fatigue problems were reported immediately after welding. Post-weld treatment techniques remove weld defects, reduce the stress concentration at the weld toe, and retard the crack initiation life, thus improving the fatigue strength [12]. A significant amount of research has been performed to investigate post-weld treatment methods such as peening [13–16], grinding [17], and tungsten inert gas (TIG) dressing [18–21].

TIG dressing is an important industrial technique that produces more effective benefits than grinding [17]. However, the efficiency of this treatment is lower than the efficiency of peening [13,14]. TIG dressing is presented using three parameters: geometry (radius at the weld toe), residual stress (RS_{TIG}) [24], and depth of treatment penetration (a_{TIG}) [20,22,23].

The International Institute of Welding (IIW) has recommended methods for improvement of as-welded steel structures using TIG dressing. IIW reported an increase in fatigue life by a factor of 3.4 without any improvement in the slope of the S–N curve [12]. Yildirim [25] examined the available data points in the literature for welded joints that were improved via TIG dressing and showed that an S–N curve with a slope of 4 is more representative of the TIG dressing method. However, these studies ([12;25]) are limited to newly as-welded structures and lack indications of the applicability of the method to pre-fatigued as-welded structures.

Many studies have focussed on TIG efficiency in the planning inspection of the extended fatigue life. Ramalho *et al.* [26] investigated the effect of TIG dressing on cracked T-joint details and showed that TIG dressing extends the fatigue life by a factor of 2.5 when the crack is completely removed. They concluded that no significant improvement occurred in fatigue life when TIG did not completely remove the crack. Fisher *et al.* [27] performed TIG treatment of a cover plate with a crack depth of 1.5–7 mm (at the weld toe) and concluded that TIG dressing completely removes the cracks from the weld toe but causes failure in the root in some cases. Miki *et al.* [28] investigated the pre-fatigued longitudinal and transversal attachments and showed that the efficiency of TIG dressing depends on two factors: the depth of the crack to be treated and the depth of TIG penetration (a_{TIG}). [26–28] presented extensive test results of repairing pre-fatigued steel structures by TIG dressing. Manai [29] summarises these studies.

These studies, however, had the following limitations: (1) they do not provide a detailed framework to assess and repair welded steel structures by TIG dressing; (2) they do not provide recommendations to estimate the damage distribution in pre-fatigue structures; and (3) they do not predict the extended fatigue life by TIG dressing treatment.

To overcome these limitations, this study proposes a detailed framework for assessing and strengthening ageing (pre-fatigued) welded steel structures using TIG dressing. The theories and guidelines that are necessary to assess aged structures, estimate the damage distribution, and predict the extended fatigue life are also provided. The proposed framework recommends countering various issues, such as the dependency between the extended fatigue life and the remaining crack after treatment, as well as the lack of control of TIG parameters. Initially, the study presents the developed framework. Second, two case studies are discussed to verify the predicted fatigue life after treatment. Last, a recommendation to extend the fatigue life is presented.

2. Framework

A framework to assess and repair a pre-fatigued welded steel structure using TIG dressing is developed in this section. The uncertainty of the input parameters in the pre-fatigued phase and the treatment phase substantially affect the extended fatigue life. The important parameters in the pre-fatigued phase are weld geometry [30,31], weld residual stress distribution RS_{AW} [32], and crack depth a_0 (which will be treated in the repairing phase). The parameters from the treatment phase are geometry after TIG [24], TIG residual stress RS_{TIG} , and TIG penetration depth a_{TIG} [20]. Determining these parameters more specifically is essential to accurately predict the fatigue life after treatment. The proposed framework provides precise damage accumulation models and defined

parameters to assess the pre-fatigued structures. Recommendations regarding the size of the treated cracks to predict the improvement in fatigue life are presented. The proposed framework is applicable to deterministic approaches that involve the use of design values (mean values) of input parameters (from the pre-fatigued and treatment phases). The framework is divided into three blocks: block A, block B, and block C, as shown in Fig. 1. In block A, a brief outline of various fatigue assessment approaches is presented with recommendations for selecting a suitable approach. The extended fatigue life after TIG dressing is estimated in block B. Evaluation of the gain in the fatigue life, which can determine the efficiency of the TIG dressing treatment, is provided in block C.

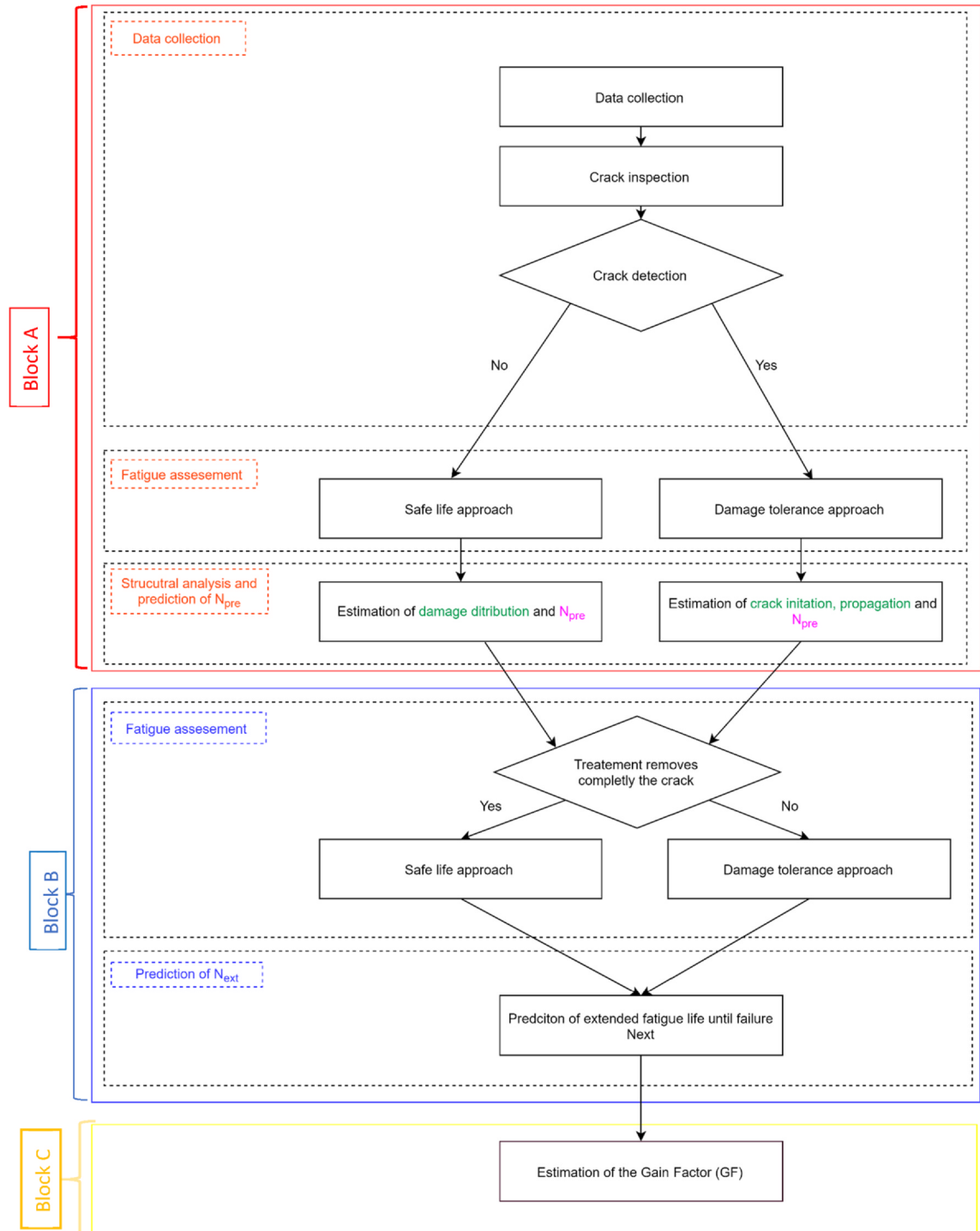

Fig. 1. Framework block A, block B, and block C.

Recommendations are made based on each treated crack depth. The proposed framework is shown in Fig. 1, and a detailed explanation regarding each block is provided in the following sub-sections. In Fig. 1, the red rectangle presents block A, the blue rectangle presents block B, and the yellow rectangle presents block C. The dashed rectangles inside each block present the corresponding steps. The green text indicates the unknown variables to be determined. The pink text indicates the variable to be determined if they are not provided in the collected data.

2.1. Block A: Assessment and evaluation of the pre-fatigued state of the structure

The aim of this block is to more accurately assess the state of the pre-fatigued welded steel structure by providing damage models and theories of fracture mechanics.

2.1.1. Data collection

Data collection is the most important step in this framework. Documents that detail the design phase, in-service phase, and the current state of the structure (which is to be treated) are needed to assess the structure.

(a) Design, fabrication, and construction phase

This phase includes design documents that contain the design codes/standards employed during the design phase, loading details, structural calculations, and available finite element analysis, as well as the fabrication and construction reports.

(b) In-service phase

This phase includes records of incidents or accidents during the service life and damage and modification to structures. Material testing reports should be collected to document the status of structural degradation and any potential fatigue cracks. All repairs that are performed during the in-service life should be listed.

(c) The current state of a structure

This phase includes the pre-fatigued state of a structure (that is to be treated) and the current set of codes and standards that can address life extension.

2.1.2. Selection of the fatigue assessment approach

The collected data should be analyzed to quantify the degree of structural degradation, such as the crack depth and the amount of accumulated fatigue damage. Two cases are discussed: the first case involves pre-fatigue welded details that contain cracks of a certain size, and the second case involves uncracked structures with accumulated microscopic damage due to fatigue. The selection of the appropriate fatigue assessment approach is crucial for the assessment process; therefore, two distinct fatigue assessments are selected to address each case according to the IIW recommendation [31] and Eurocode [33].

(a) Damage tolerance approach

This approach is applicable to cases in which the pre-fatigued structures contain cracks. This method is based on the crack growth law, which can be represented, for example, by the Paris law in [34] (Eq. (1)). However, other models of fracture mechanics and crack growth law are applicable ([35–37]).

$$\frac{da}{dN} = C(\Delta K)^m \quad (1)$$

where $\frac{da}{dN}$ is the crack growth rate, ΔK is the stress intensity factor range, and C and m are the constants that depend on the material. The stress intensity range ΔK can be expressed using Eq. (2)

$$\Delta K = K_{max} - K_{min} \quad (2)$$

where K_{max} and K_{min} are the maximum stress intensity factor and the minimum stress intensity factor, respectively, which correspond to the maximum stress range and minimum stress range, respectively.

(b) Safe life approach: S-N method

The safe life approach is selected to predict the crack initiation life of pre-fatigued structures that do not show any cracks. The notch stress approach ([31,38]) is recommended to estimate the damage accumulation and crack initiation life of welded details with the corresponding S–N curve.

2.1.3. Structural degradation analysis and estimation of N_{pre}

This subsection depends on the state of the pre-fatigued structure and provides an analysis of the collected data. The aim of this

subsection is to estimate the damage distribution in a pre-fatigued structure and the number of cycles applied in the pre-fatigued phase N_{pre} (if it was not provided in the collected data) using the weld toe radius (R_{AW}), weld residual stress distribution (RS_{AW}), depth of treated cracks a_0 , material properties (S–N curve), and applied load. Four cases can be found. In the first case, if N_{pre} is provided (in the collected data) and the pre-fatigued structure does not show any cracks, the cumulative damage should be calculated based on the safe life S–N approach. In the second case, if N_{pre} is provided and the pre-fatigued structure is cracked, then no calculation is required because all information for the continuation of the framework is provided. In the third case, if N_{pre} is not provided and the structure does not show any cracks, the estimation of N_{pre} and the damage distribution are required. In the fourth case, if N_{pre} is not provided and the structure shows cracks (a_0 mm depth), prediction of N_{pre} is required. In Section 2.1.3.2, more precise estimations of damage distribution, crack propagation, and N_{pre} are provided.

In Fig. 2, the dashed frames present the steps, the red text presents the title of the step, and the green text represents the unknown variables. The pink text presents unknown variables to be determined (if they are not provided in the collected data).

2.1.3.1. Parameters

- Weld residual stress (RS_w)

By definition, RS illustrates the stress distribution, which can exist in structures when no external load is applied. A probabilistic study of weld RS has been performed [32]. The mean shape of the weld RS distribution at the weld toe in the thickness direction was provided, as shown in Fig. 3, where ‘ f_y ’ is the yield stress, ‘thickness’ is the thickness of the main welded plate, and ‘RS’ is the residual stress.

According to the collected data, three different cases of weld RS can be found. The possible cases and their corresponding recommendations are detailed as follows. In the first case, if the collected data provide complete information regarding the shape of the RS, it is advisable to use this information. In the second case, if the available collected data has only information about the surface weld residual stress and does not provide the shape of the subsurface residual stress, estimation of the latter using a linear relationship between the surface RS and the subsurface RS is recommended [32]. In the third case, if information about the weld RS is not available from the collected data, the use of the shape presented in Fig. 3 for the continuation of the framework application is recommended.

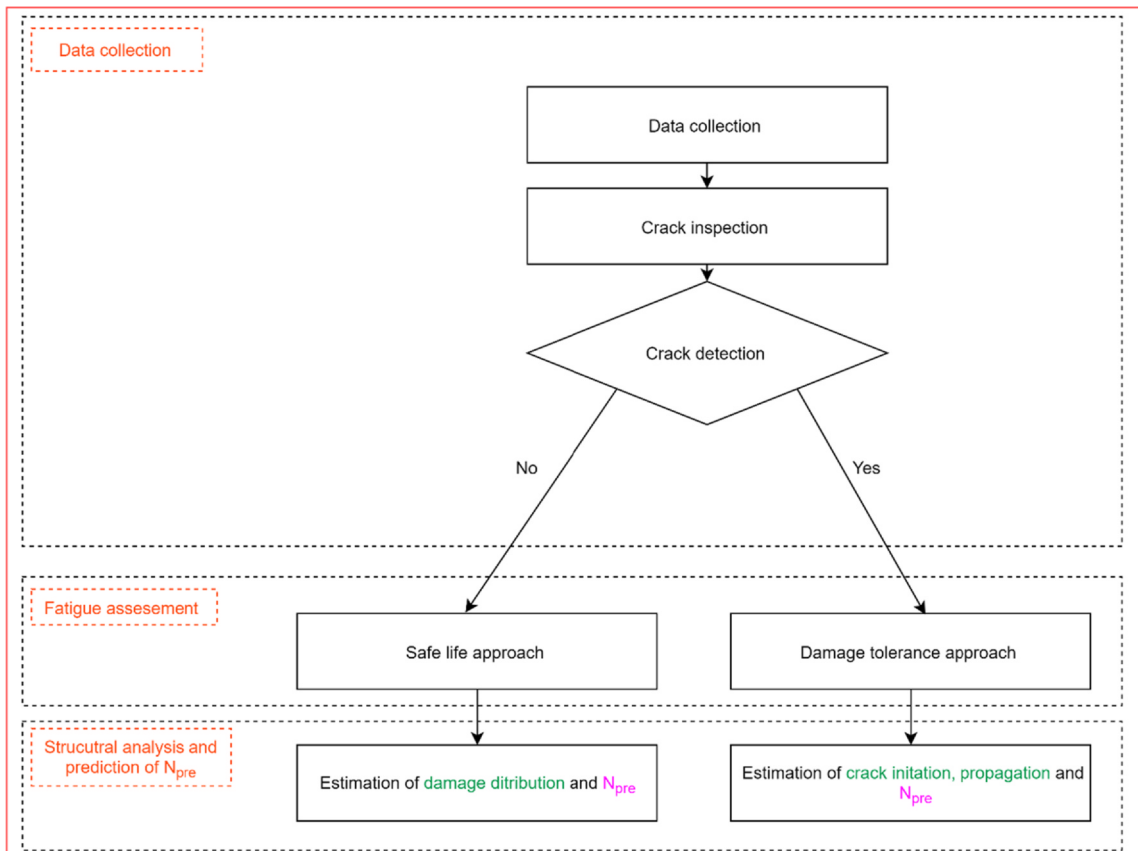

Fig. 2. Block A, assessment and evaluation of the pre-fatigued state of the structure.

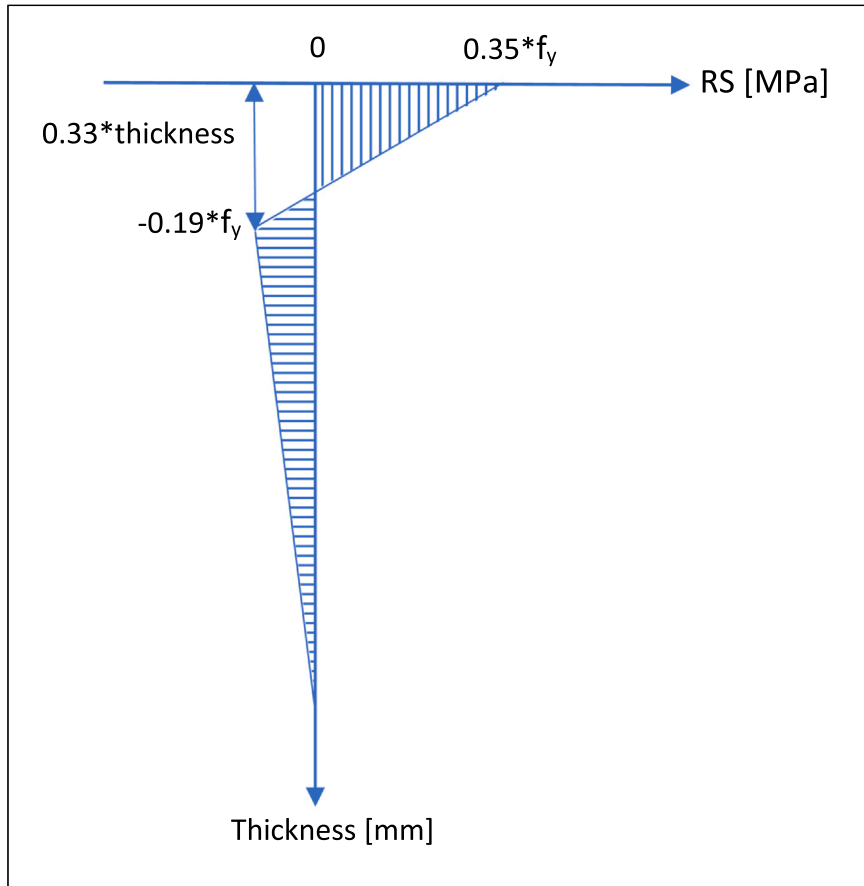

Fig. 3. Mean shape of weld residual stress at the weld toe in the thickness direction.

- Weld geometry parameter:

Welding is a variable process that introduces variations in the weld geometry, particularly in the weld radius. Previous studies have shown that the weld radius depends on details such as the weld metal and type of attachment (longitudinal attachment, transversal attachment, and T joints). It is advisable to use the given value of the weld toe radius if it is provided in the collected data. If the weld toe radius is unavailable, IIW [31] and [32] recommend a radius of 1 mm for any weld joint.

2.1.3.2. Damage distribution and crack initiation. The stress concentration K_t along the thickness of the main plate is obtained using a finite element analysis. Using the notch stress approach and weld toe radius (R_{AW}), the notch stress factor K_f can be defined [38].

Mean stress correction is performed based on the external loads, weld RS, stress concentration factor K_t , and notch stress factor K_f . In this study, Morrow law [45] is selected for mean stress correction. However, other mean stress correction laws are also applicable. This mean stress correction enables the applied stress amplitude σ_{ar} to be defined considering the weld toe radius and the RS to predict fatigue life using the safe life approach S-N curve.

With the S-N curve of crack initiation and σ_{ar} , the crack initiation life (N_{ci}) can be predicted. If the pre-fatigued structure is non-cracked and N_{pre} (pre-fatigue life cycles) is provided, then the accumulated damage can be estimated using the Palmgren-Miner rule (Eq. (3)).

$$D = \frac{N_{pre}}{N_{ci}} \quad (3)$$

If N_{pre} is not provided and the structure does not show any cracks, the estimation of N_{pre} is needed. In this case, the assumption that the structure is in the crack initiation phase is adopted [4]. In this case, N_{pre} is assumed to be equal to N_{ci} .

2.1.3.3. Crack propagation. In cases where N_{pre} is unknown and the structure shows a crack with a depth of a_0 mm, it is advisable to predict crack initiation and propagation life (until a_0 mm). From Section 2.1.3.2., the crack initiation life is determined. With the theories of linear fracture mechanics, crack size (a_0 mm), and crack growth law [34], the number of cycles to crack propagation to a maximum size of a_0 mm ($N_{crack\ growth}$) can be computed. Section 2.1.2 provides more details regarding crack propagation. The

predicted N_{pre} is expressed using Eq. (4).

$$N_{pre} = N_{ci} + N_{crack\ growth} \quad (4)$$

2.2. Block B: Treatment analysis and estimation of the extended fatigue life

TIG dressing is an important industrial technique that is more efficient than grinding but less efficient than peening [46]. TIG dressing removes the weld defects, re-melts the material to a certain penetration depth (a_{TIG}) [20,22,23], increases the weld toe radius (R_{TIG}), and reduces the weld residual stress (RS_{TIG}) [24].

The state of the repaired pre-fatigued structures depends on the state of the pre-fatigued structure before treatment. Two cases could be found. In the first case, the treatment re-melts the damaged area completely removes the weld defects and cracks (if they exist) and produces a structure without cracks. In the second case, the treatment does not completely remove the cracks, and subsurface cracks remain in the structure after treatment.

2.2.1. TIG dressing treatment method

If the TIG fusion depth is a_{TIG} mm, the material at the weld toe to a maximum depth of a_{TIG} mm is re-melted. This finding implies that the damaged material, weld defects, and cracks to a depth of a_{TIG} mm were completely removed. When the pre-fatigued structure has cracks deeper than a_{TIG} mm, subsurface cracks remain on the structure (refer to Fig. 4).

In cases with completely re-melted cracks after TIG dressing, the safe life S-N approach is utilized to estimate the fatigue life. For cases where undemolished cracks remain even after treatment, however, the damage tolerance approach is the appropriate fatigue assessment approach for estimating fatigue life. The two fatigue assessment approaches are provided in Section 2.1.2.

2.2.2. Estimation of the extended fatigue life

Parameters

- TIG residual stress, RS_{TIG}

RS has an important impact on fatigue life, which can be either beneficial or harmful. This effect can be beneficial when compressive RS is introduced, as demonstrated by the increase in the crack initiation period [12,13]. However, this effect can be harmful when tensile RS is introduced; this disadvantage can be observed in the reduction of the crack initiation period. Thus, the TIG RS is considered in the estimation of fatigue life. However, the information regarding the TIG RS distribution is not always available for the investigated structure. The three different possible cases regarding the accessibility of RS_{TIG} and their corresponding recommendations are detailed as follows. In the first case, if the TIG RS distribution of the weld toe in the thickness direction is provided, it is advisable to use this distribution. In the second case, if only the surface magnitude of TIG RS is provided, according to

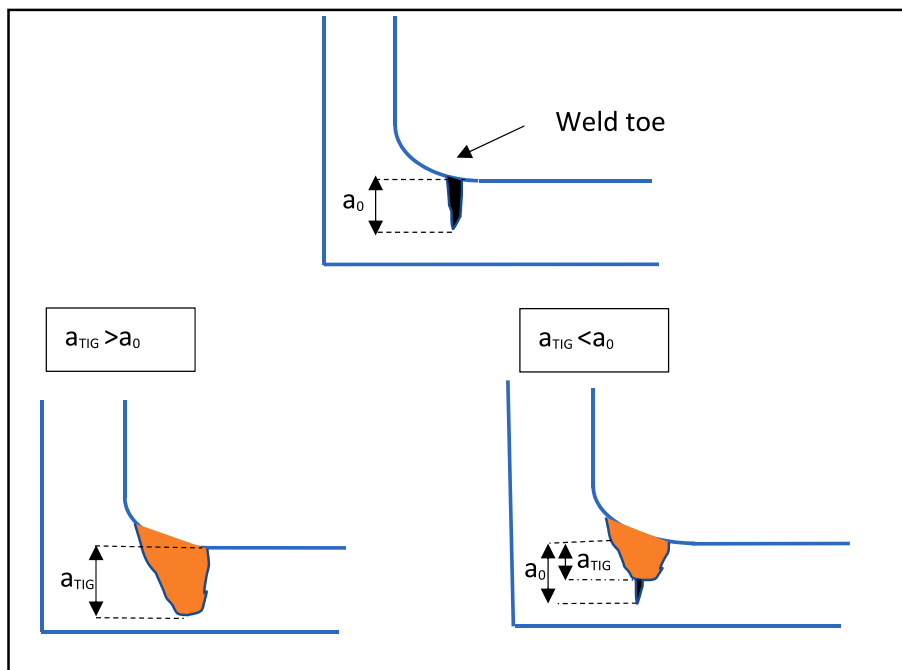

Fig. 4. Cases of the structure after treatment.

[32], the subsurface RS distribution at the weld toe can be estimated and applied. In the third case, if no RS from TIG dressing is provided, the use of the weld RS distribution presented in [32] is recommended.

- TIG radius: R_{TIG}

The geometry improvement introduced by TIG dressing emerges as an increase in the weld toe radius, which reduces the stress concentration at the weld toe. Regarding the available information of the weld toe radius, two possible cases could exist. The first case is that the weld toe radius for a structure is provided. In this case, it is advisable to use this value for the application of the framework. The second case is that the weld toe radius is not provided, wherein according to IIW [12] the use of $R_{TIG} = 5 \text{ mm}$ is recommended.

- Penetration depth: $a_{TIG \text{ IIW}}$

This parameter is the determinant of the selection of the corresponding fatigue assessment approach. The penetration depth (a_{TIG}) can have two cases of availability. The two possible cases and their corresponding recommendation are presented as follows. In the first case, if a_{TIG} is provided within the collected data, the use of this value is recommended. In the second case, if a_{TIG} is not provided, according to IIW [12,26] and [28], the use of $a_{TIG} = 3 \text{ mm}$ is recommended.

As previously mentioned, the weld toe radius (R_{TIG}) reduces the local stress concentration, and the TIG residual stress (RS_{TIG}) changes the mean stress. Thus, the TIG radius and the TIG RS affects the applied stress range. Eq. (5) shows the integration of these two factors in the calculation of the applied stress range in Morrow law. Note that a_{TIG} is employed in the selected fatigue assessment approach.

$$\sigma_{ar} = \frac{\frac{\Delta\sigma}{2}}{1 - \frac{\sigma_m + RS_{TIG}}{\sigma_f}} \tag{5}$$

where $\Delta\sigma$ is the stress range obtained from FEM considering the weld toe radius (R_{TIG}), σ_m is the mean stress, RS_{TIG} is the residual stress from TIG dressing, σ_u is the ultimate tensile strength, and σ_{ar} is the stress amplitude with zero mean stress

2.3. Block C: Estimation of the gain factor

The gain factor is defined to quantify the efficiency of TIG dressing in fatigue life improvement [12]. As shown in Eq. (6), this gain equals the ratio between the extended fatigue life of the treated structure and its as-welded fatigue life.

$$GF = \frac{N_{ext}}{N_{fAw}} \tag{6}$$

where N_{fAw} is the fatigue life of the as-welded structure and N_{ext} is the extended fatigue life of the treated structure.

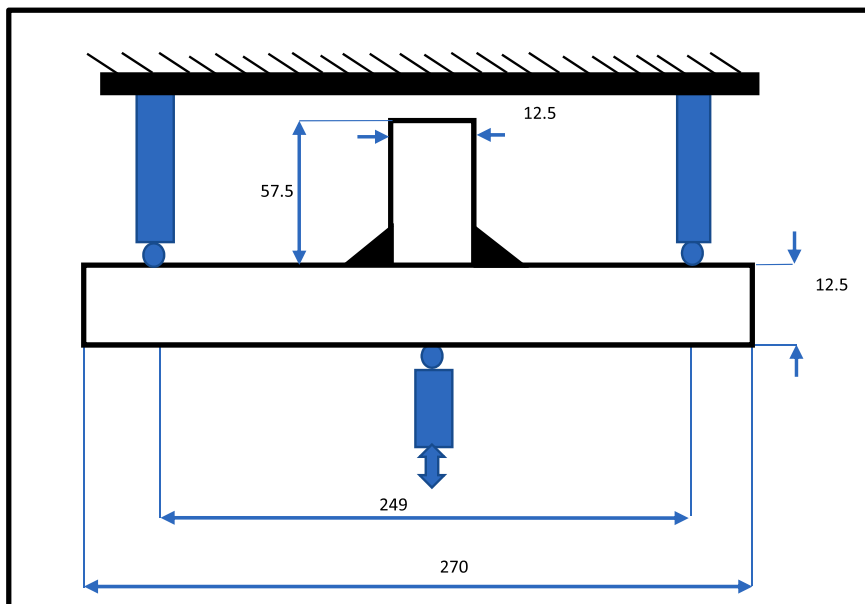

Fig. 5. Geometry of the tested specimen.

3. Case study 1: Verification of the framework by tests from studies [26]

In this case study, the only provided data include those from [26], which contains information regarding the manufacturing phase of the specimen, material properties, finite element simulations, and load characteristics. An analysis of the provided information within [26] was conducted to identify the degree of structural degradation and verify the extended fatigue life.

3.1. Assessment of the pre-fatigued structure

Ramalho et al. [26] studied the pre-fatigued specimens treated by TIG dressing. The tested specimens had a transversal attachment manufactured with medium-strength steel St-3DIN 17,100 with a yield strength of 384 MPa and ultimate stress of 555 MPa. The specimens were produced from main plates with a thickness of 12.5 mm and a low penetration fillet welded with an attachment of equal thickness. The final specimens were cut into pieces with a thickness of 270 mm. Fig. 5 shows the geometry and dimensions of the specimens.

The as-welded specimens were submitted to bending loading (refer to Fig. 5) with a stress ratio $R = 0$ until an increase of 10% in the initial deformation at the weld toe was registered. This increase in deformation was caused by the initiation and propagation of fatigue cracks with a maximum depth of 3 mm. The number of cycles (N_{pre}) was recorded until this increase in deformation was registered. The two collected pieces of data—the number of applied loading cycles (N_{pre}) and resulting crack depth—enabled the assessment of the state of the pre-fatigued structure and continuation of the framework.

3.2. Repairing by TIG dressing

All pre-fatigued specimens contained cracks. After the specimens were treated, two outcomes are possible after inspection. In the first outcome, TIG treatment completely removed the crack; in the second outcome, cracks remained in the structure. In the following subsection, an analysis of the information in [26] regarding TIG dressing is presented.

3.2.1. Identification of TIG dressing parameters

The pre-fatigued specimens were re-habilitated by TIG dressing techniques by using the parameters listed in Table 1.

A statistical analysis of the radius at the weld toe, after TIG dressing, showed an average value of 6.25 mm with a standard deviation of 1.99. The fatigue strength of the welded joints was strongly affected by a TIG RS field at the weld toe [24]. In these tests, two different techniques were used to measure the surface RS at the weld toe: X-ray diffraction and the hole drilling method. The measurements were conducted for a randomly selected specimen and showed that the TIG dressing introduced a (compressive) RS of -80 MPa at the weld toe. The subsurface RS distribution at the weld toe can be predicted based on the surface-measured value of RS and the model developed in [32]. Fig. 6 shows the estimated TIG RS distribution.

The radius of the weld toe is used to compute the stress concentration factor. This factor showed a decrease from 1.76 (in the as-welded state) to 1.4 (after TIG dressing treatment) due to radius smoothing. The depth of a_{TIG} was used to determine whether the treatment completely removes the crack when $a_0 < a_{TIG}$ or whether a subsurface crack remains when $a_0 > a_{TIG}$. Thus, the depth of TIG penetration enables the selection of a suitable fatigue assessment approach. In this study, a_{TIG} was not provided for each specimen. The recommended value for a_{TIG} of 3 mm was used [12,18,21].

3.2.2. Estimation of the extended fatigue life

In these tests, all information required to estimate the state of a structure after applying the TIG treatment by the proposed framework was identified. Based on the state of each specimen after treatment (with cracks or without cracks), the corresponding fatigue assessment approach was selected. A comparison between the experimental extended fatigue life after TIG treatment and the predicted extended fatigue life after TIG treatment is shown in Fig. 7. The predicted extended fatigue life is within the error band of $\pm 20\%$ of the experimental fatigue life. In most tests, the predicted extended fatigue life is lower than the experimental fatigue life, which results in an underestimation of the extended fatigue life. In these tests, for most of the treated specimens, cracks remain after treatment, which caused a lower extended fatigue life (less than $1E6$ cycles).

3.3. Gain factor

To assess the efficiency of TIG treatment, a calculation of the gain factor in fatigue life (Eq. (6)) is required. Within this case study,

Table 1
TIG dressing parameters.

TIG dressing parameters
Argon flux
Current intensity – 110 A
Tension DC – 19 V
Linear rate – 1.08 mm/s

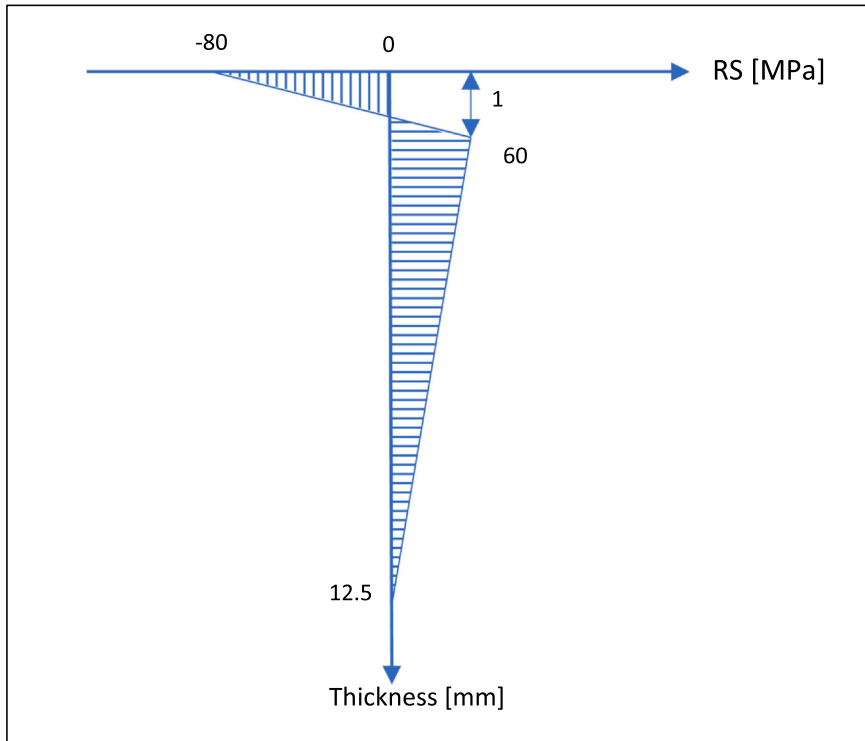

Fig. 6. Estimated TIG residual stress distribution at the weld toe in the thickness direction.

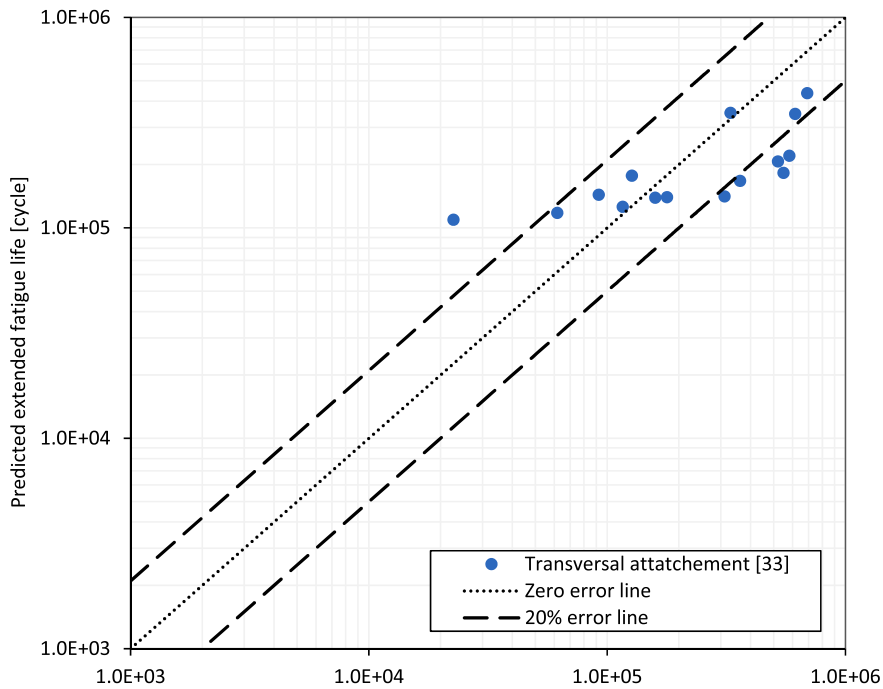

Fig. 7. Comparison between the experimental extended fatigue life and the predicted extended fatigue life.

the as-welded fatigue life for each specimen was given ($N_{f,AW}$).

Fig. 8 shows two points (two gain factors)—triangles and circles—for each size of the remaining cracks. The triangle represents the predicted gain factor and the square represents the corresponding experimental gain factor.

The following preliminary conclusions can be obtained from this study:

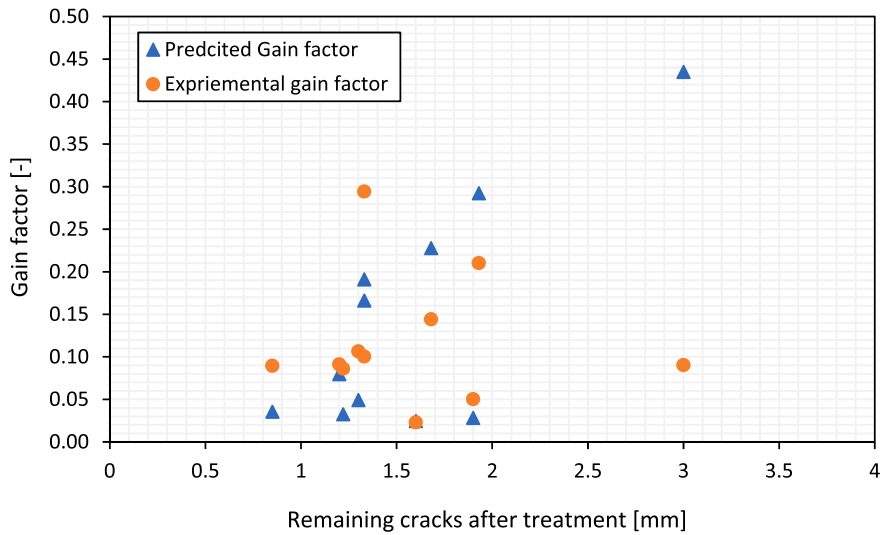

Fig. 8. Gain in fatigue life as a function of the remaining cracks.

- One possible explanation of the error between the predicted gain factor and the experimental gain factor is because, within this test series, there is no information about the TIG dressing penetration depth, which means that in some specimens, some real (physical) cracks remain (the extended fatigue life covers the crack propagation period). In contrast, when the recommended a_{TIG} was used, it was found that no cracks remained in the structure (the extended fatigue life included the crack initiation life and the crack propagation life).
- The extended fatigue life is strongly dependent on the crack size after treatment. High gain factors were obtained for a small remaining crack, whereas a low gain factor was noted for a high remaining crack.
- The gain in the fatigue life of structures that contains cracks after treatment is lower than 0.5.
- According to IIW [12], a new as-welded treated structure showed an increase in the fatigue life of 3.4. The extended fatigue life of pre-fatigued structures that contain cracks after treatment was lower than the fatigue life of the new as-welded TIG treated structures.
- The TIG dressing treatment is not efficient for treating deep cracks—cracks deeper than the fusion depth (a_{TIG}).

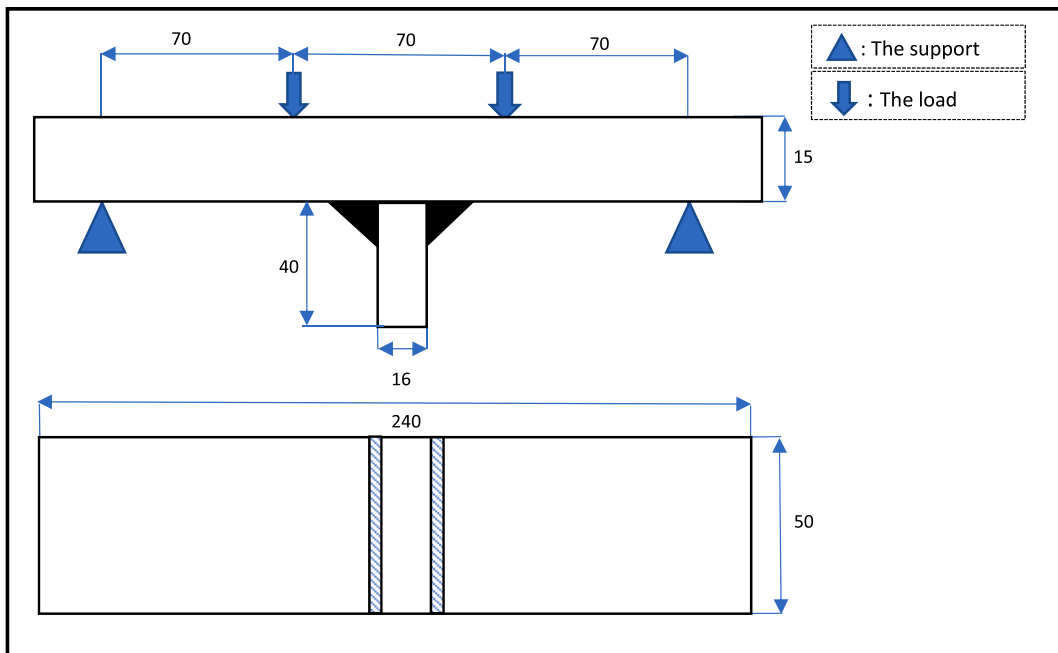

Fig. 9. Dimensions of the transversal attachment in mm.

4. Case study 2: Verification of the framework by tests from studies [28]

In this case study, the only provided document is the study of Miki *et al.* [28]. Here, the material properties, manufacturing process, and load characteristics were provided. This study was analyzed to extract information to assess pre-fatigued specimens and predict the extended fatigue life after treating these specimens by TIG dressing.

Miki *et al.* [28] investigated the effect of TIG dressing on repairing pre-fatigued fillet-welded joints, which were transversal and longitudinal attachments. The configuration and dimensions of the specimens are shown in Fig. 9 and Fig. 10, respectively. The material of the main plates was SM58 steel, and the material of the attachment plates was SM50 steel. Table 2 lists the mechanical properties of these materials. Welding was manually performed using low-hydrogen-type electrodes [28]. Fatigue tests were performed by four-point bending (refer to Fig. 9 and Fig. 10). The stress ratio for all tests was 0.1.

4.1. Block A: Assessment and evaluation of the pre-fatigued structures

Forty as-welded specimens (20 longitudinal attachment and 20 transversal attachment) were submitted to 450,000 load cycles. After this loading stage, non-destructive tests (dye penetrant and ultrasonic tests) were employed to detect the dimensions and shapes of any probable cracks. For some specimens, no cracks were detected, whereas cracks with depths from 2 to 6 mm were detected at the weld toe in other specimens.

For specimens that did not show any cracks, the safe-life approach S–N curve was selected to estimate the damage accumulation according to Section 2.1.3.2. For cracked specimens, the pre-fatigued state was well defined because the crack dimension and number of applied load cycles were provided in [28].

4.2. Block B: Treatment analysis and estimation of the extended fatigue life

The pre-fatigued welded joints were repaired by TIG dressing. For some specimens, the initial cracks were completely re-melted (removed), while some cracks remained inside the patent plate for other specimens.

4.2.1. Identification of TIG treatment parameters

In [28], the average value of the weld toe radius after TIG treatment was measured to be 5 mm. The fusion depth of TIG ranged from 3 to 4 mm. No RS after TIG dressing treatment was measured. Therefore, the shape of RS provided in [32] is used.

4.2.1.1. Estimation of extended fatigue life. For each treated specimen, regardless of whether a crack is detected, a suitable fatigue assessment approach is selected to estimate the extended fatigue life with the identified TIG dressing parameters.

Fig. 11 and Fig. 12 show the experimental points and their fitted lines, as well as the predicted S–N curves for pre-fatigued treated specimens for transversal attachment and longitudinal attachment for other specimens, respectively.

In a preliminary analysis of the obtained S–N curves, some relevant aspects are noted:

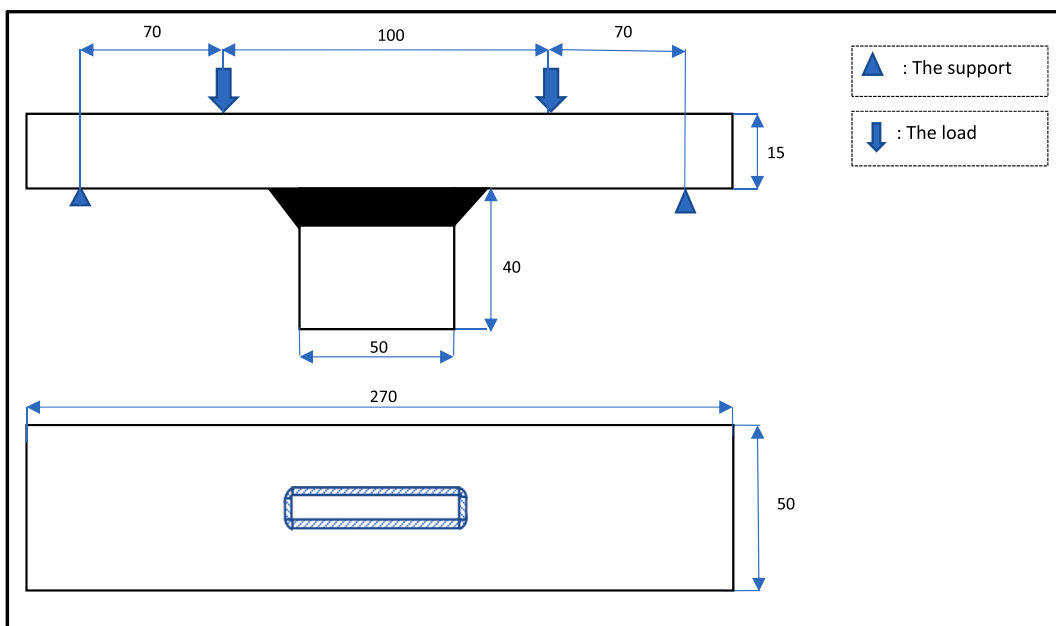

Fig. 10. Dimensions of the longitudinal attachment in mm.

Table 2
Mechanical properties of SM58 and SM50 steel.

Material	Mechanical properties	
	Yield strength [MPa]	Tensile strength [MPa]
SM58	590	680
SM50	410	560

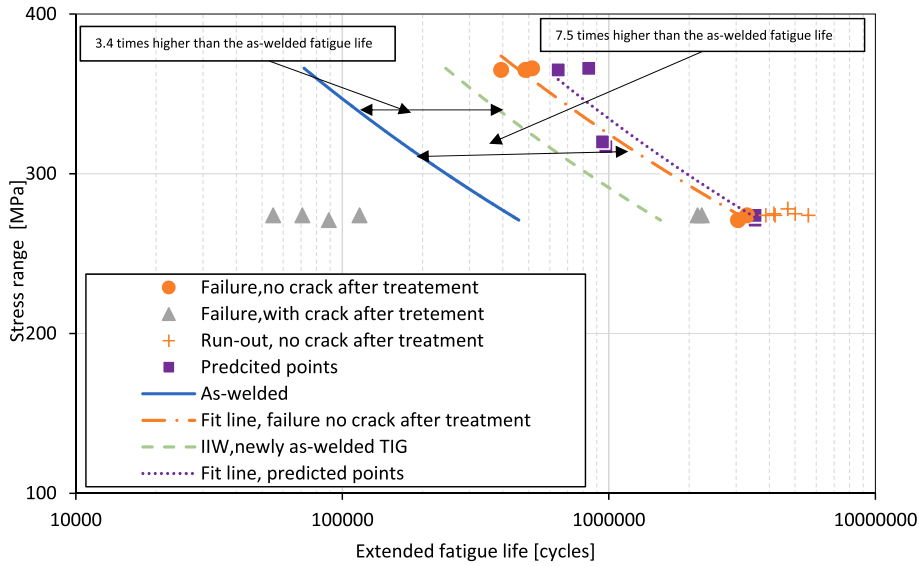

Fig. 11. S-N curves of longitudinal attachment.

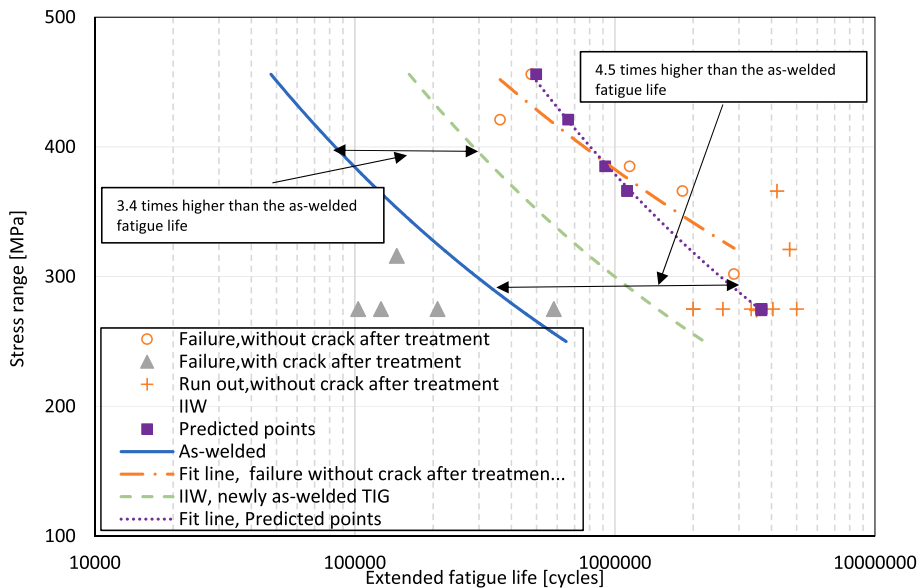

Fig. 12. S-N curve of transversal attachment.

- The experimental and predicted fatigue life of specimens treated by TIG dressing are distinctly higher than those of the as-welded fatigue life.
- The predicted fatigue life of the treated structures using the recommended TIG RS are similar to the experimentally obtained fatigue life.
- The fatigue strength of welded joints is strongly affected by the RS field at the weld toe.
- When TIG completely removes the cracks, the fatigue life of the pre-fatigued treated structure is higher than the recommended

fatigue life by IIW.

- The improvement in the fatigue life is 7.5 times the improvement in the as-welded fatigue life for longitudinal attachment.
- The improvement in fatigue life is at least 4.5 times the improvement in the as-welded fatigue life for transversal attachment.

Fig. 13 shows a comparison between the experimental fatigue life and the predicted extended fatigue life, transversal attachment and longitudinal attachment. The predicted extended fatigue life falls within the error band of 25% of the experimental extended fatigue life. Thus, using the same RS as in [32], the results agree reasonable. The extended fatigue life of the cracked structures (after treatment) is low compared with the extended fatigue life of non-cracked structures after treatment.

The fatigue life of TIG treated specimens is higher than the fatigue life of the as-welded specimens regardless of whether the TIG dressing can completely remove the cracks. The highest improvement in fatigue life was detected when TIG successfully removed the cracks completely. Thus, the extended fatigue life includes the crack initiation period of the treated structure.

Note that all specimens failed at the welded toe, which concludes that the fatigue life is strongly influenced by the state of the weld toe after treatment. As previously mentioned, all TIG parameters were provided in this case study, except the TIG RS, which was recommended by the shape in [32].

In the case where TIG dressing completely removes the cracks, the impact of the initial crack size in the prediction of fatigue life was investigated. Fig. 14 shows the predicted and the experimental points of the extended fatigue life as a function of the initial crack for a stress range of 275 MPa for longitudinal attachment. Independent of the crack size before treatment, the predicted extended fatigue life was 3.8E6 cycles. The experimental results show a scatter of the extended fatigue life from 3 to 4.8 million cycles for cracks with a depth between 0.7 and 4 mm. If TIG dressing completely removes the initiation cracks, the extended fatigue life is independent of the crack size before treatment.

5. Recommendation

The recommendations provided in [12] and [25] are limited to new as-welded structures treated by TIG dressing. The experimental studies [26,27], and [28] present an extensive series of tests for different weld joints to study the efficiency of TIG dressing to treat a pre-fatigued welded structure. In this section, an analysis of numerous tests and the proposed framework is provided to extract the recommendation for a pre-fatigued structure treated by TIG dressing.

- 1- When TIG dressing completely removes the initial crack, the initial crack depth does not influence the extended fatigue life.

Fig. 15 presents the experimental results of the extended fatigue life as a function of the crack before treatment for transversal attachment [28]. For example, in Fig. 15, when the stress is 275 MPa, independent of the crack before treatment, which varies between 1 and 4 mm, the extended fatigue life falls within the range of 3.5E6 to 5E6 cycles. When the stress is 366 MPa, the treatment of cracks with a depth of 1.4 or 3.1 mm produces an extension in fatigue life of 3E6 to 4.5E6 cycles.

- 2- When TIG dressing does not completely remove the initial crack, the dependency between the extended fatigue life and the remaining crack after treatment is significant.
- 3- Fig. 16 presents the gain factor as a function of the remaining cracks for the collected data of pre-fatigued specimens tested by TIG

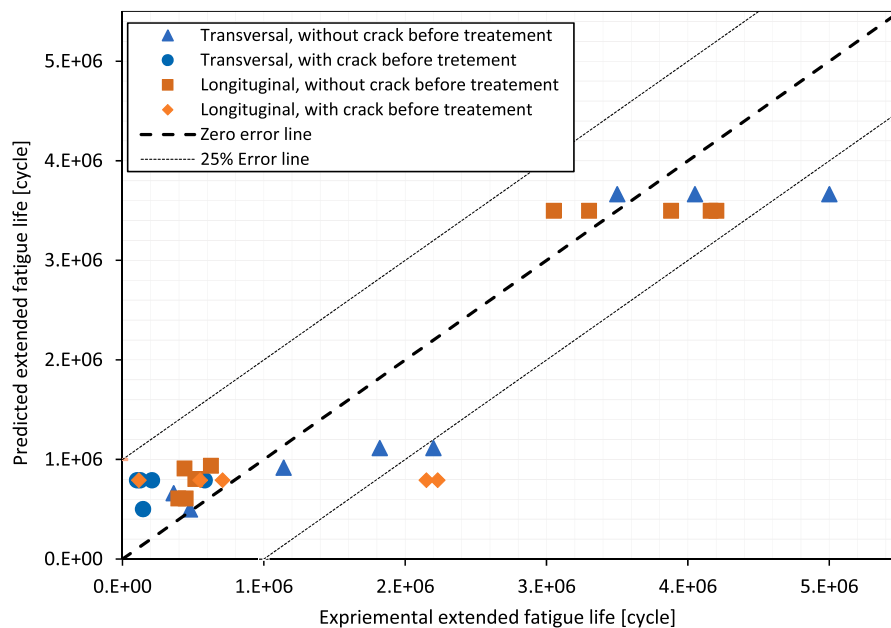

Fig. 13. Comparison between experimental extension and predicted extension in fatigue life for transversal and longitudinal attachment.

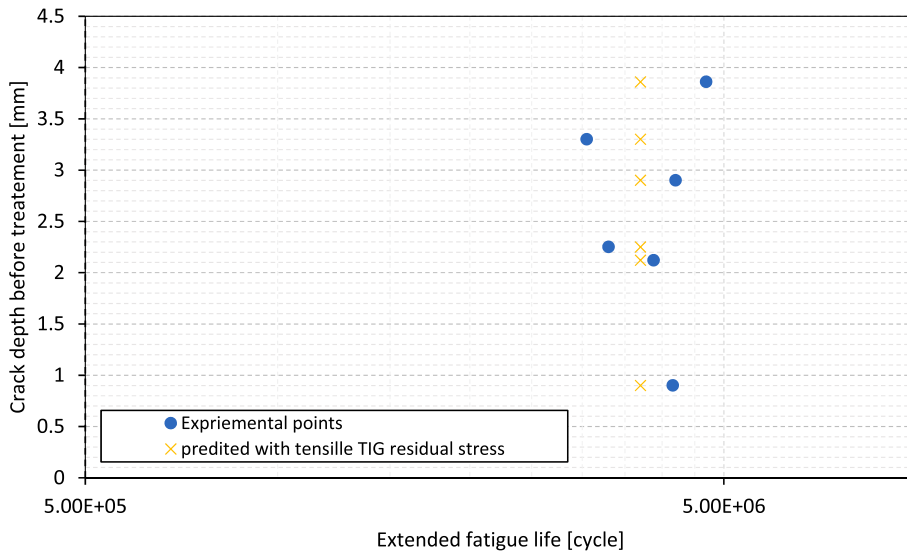

Fig. 14. Cracks completely removed after TIG treatment: cracks before treatment as a function of the extended fatigue life.

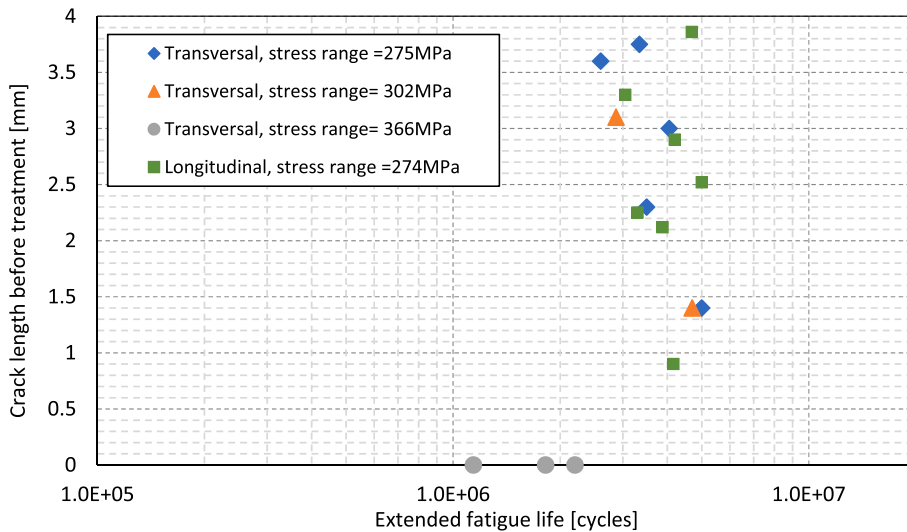

Fig. 15. Size of removed cracks as a function of the extended fatigue life.

dressing (transversal attachment, longitudinal attachment, and cover plate). If the crack is entirely removed, the extended fatigue life is at least 3.4 times as large as the as-welded fatigue life. If a crack remains after TIG dressing treatment, the extended fatigue life depends on the remaining crack size. In the investigated database the extended fatigue life is at least 10% the as-welded fatigue life. When the gain factor is less than 3.4, the case corresponds to root failure and not toe failure.

6. Discussion

In [26] and [28], an extensive series of tests was conducted. These tests addressed different possible scenarios of the proposed framework. Fig. 17 shows the following different scenarios:

1. Pre-fatigued no-cracked structure treated by TIG dressing (no crack after TIG dressing treatment).
2. Pre-fatigued cracked structure treated by TIG dressing, where the crack is not completely removed (with crack after treatment).
3. Pre-fatigued cracked structures treated by TIG dressing, where the crack is completely removed (crack-free after treatment).

In our developed framework, some recommendations regarding TIG dressing parameters are provided. Within the previously mentioned case studies, the recommendations regarding RS and TIG penetration depth were verified. The case studies in [26] and [28] were selected because the data were completely accessible. In these two case studies, the only provided information to assess

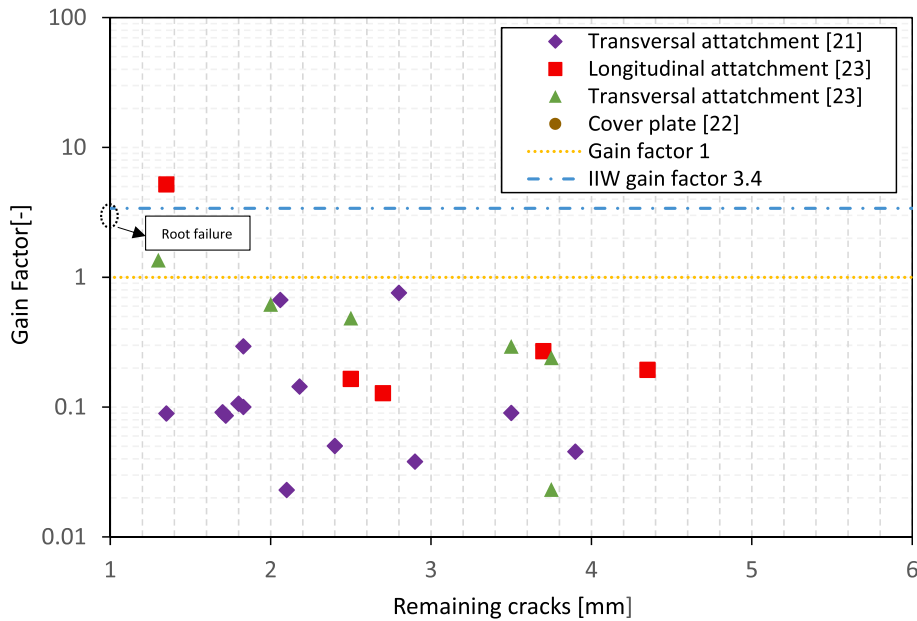

Fig. 16. Gain factor as a function of the remaining cracks after treatment.

and predict the extended fatigue life of the specimens was the scientific papers. Because these case studies did not provide any verification of the "data collection", a suitable case study should be selected to verify this step.

A limited number of welded joints, namely, longitudinal and transversal attachments (pre-fatigued and then treated by TIG dressing), were explored in these studies. These results were used to validate the proposed framework. Thus, the significance of the proposed framework should be further highlighted for other real ageing existing structures using more case studies with **different types of steel**. Thereafter, the proposed framework and given model parameters may be adopted in the assessment standards in the future.

The extended fatigue life strongly depends on the crack depth. Therefore, it is required to predict a reliable value of the crack depth for an accurate prediction of fatigue life extension. However, in real structures, the crack measurement can be difficult to achieve. Several non-destructive monitoring techniques are used in the industry to detect fatigue cracks. A brief description of the non-destructive testing (NDT) methods is presented in [39] and [40].

Real structures experience different types of ageing [40–43]. The proposed framework considers only the ageing caused by fatigue. Other aspects of ageing such as corrosion, erosion, and creep have not been considered.

The proposed framework can be used for both deterministic and probabilistic analysis approaches. While the deterministic approach requires the use of design values of the parameters in the proposed framework, the probabilistic approach involves the use of a distribution function for each of these parameters. The proposed framework is applied to the considered case studies using a deterministic approach. It can also be used with probabilistic approaches.

7. Conclusion

The extension of fatigue life of ageing welded steel structures has been identified as a significant challenge. The simultaneous replacement of these structures is a major technical and constructional challenge. Strengthening these existing structures prolongs their fatigue life without the requirement of replacing them. Some studies have provided a general assessment of existing steel structures, but they do not recommend models for damage calculations and crack propagation, which is needed for an accurate prediction of the extended fatigue life.

In this study, a framework is developed to assess and improve pre-fatigued welded steel structures by TIG dressing techniques. In the assessment phase, damage models and theories of fractures mechanics are provided for an accurate evaluation of the structure. TIG parameters (toe radius, RS, and TIG penetration depth) are provided in the prediction of the extended fatigue life. The proposed framework is verified using 60 specimens from two experimental studies that discuss possible scenarios.

The following conclusions were drawn:

- Pre-fatigued specimens treated by TIG dressing have a higher fatigue strength than as-welded specimens (at least 3.4 times the as-welded fatigue life) because of the sufficient TIG dressing penetration to completely remove the initial crack.
- When TIG dressing did not completely remove the crack, the extended fatigue life was strongly dependent on the remaining crack size after treatment with no significant improvement in the fatigue life (the improvement was less than 10% of the as-welded fatigue life).



Fig. 17. Different verified scenarios of the framework.

- The fatigue strength of the treated structure was strongly affected by TIG treatment parameters, especially the TIG penetration depth (a_{TIG}).

Declaration of Competing Interest

The authors declare that they have no known competing financial interests or personal relationships that could have appeared to influence the work reported in this paper.

Acknowledgements

The author is grateful to Vinnova and InfraSweden2030 for funding the LIFEEXT project (2017-02670) and the Swedish Transport Administration (trafikverket) for funding the project BBT 2017-018. I appreciate the participants in the LIFEEXT consortia for their cooperation and valuable input.

Appendix A. Supplementary material

Supplementary data to this article can be found online at <https://doi.org/10.1016/j.engfailanal.2020.104923>.

References

- [1] W. Rücker, F. Hille, R. Rohrmann, Guideline for the Assessment of Existing Structures, SAMCO Final Report (2006).
- [2] P. Banerji, S. Chikermane, Structural Health Monitoring for Life Extension of Railway Bridges: Strategies and Outcomes, Civil Structural Health Monitoring Workshop (CSHM-4) - Keynote 2, Indian Institute of Technology Roorkee.
- [3] S.S. Chaminda, M. Ogha, R. Dissanayake, K. Taniwaki, Different approaches for remaining fatigue life estimation of critical members in railway bridges, *Int. J. Steel Struct.* (2007) 263–276.
- [4] A. Aeran, S.C. Siriwardane, O. Mikkelsen, I. Langan, A framework to assess structural integrity of ageing offshore jacket structures for life extension, *Marine Structures* (2017), Vol. 56, pp.237-259, August.
- [5] B. Kühn, M. Lukić, A. Nussbaumer, H.P. Günther, R. Helmerich, S. Herion, M.H. Kolstein, S. Walbridge, B. Androic, O. Dijkstra, Ö. Bucak, Assessment of Existing Steel Structures: Recommendations for Estimation of Remaining Fatigue Life, ECCS cooperation agreement for the evolution of Eurocode 3, 2008.
- [6] B. Kühn, Assessment of existing steel structures: Recommendations for estimation of the remaining fatigue life Fatigue design, *Procedia Eng.* 66 (2013) 3–11.
- [7] A. Manai, A literature review of pre-fatigued structures treated by TIG dressing, *IABMAS Japan* (2020).
- [8] C. Cui, Q. Zhang, Y. Bao, Y. Bu, Y. Luo, Fatigue life evaluation of welded joints in steel bridge considering residual stress, *J. Construct. Steel Res.* 153 (2019) 509–518, <https://doi.org/10.1016/j.jcsr.2018.11.003>.
- [9] J. Li, Q. Zhang, Y. Bao, J. Zhu, L. Chen, Y. Bu, An equivalent structural stress-based fatigue evaluation framework for rib-to-deck welded joints in orthotropic steel deck, *Eng. Struct.* (2019) 196, <https://doi.org/10.1016/j.engstruct.2019.109304>.
- [10] J. Fajoui, M. Kchaou, A. Sellami, S. Branchua, R. Elleuch, F. Jacquemin, Impact of residual stresses on mechanical behaviour of hot work steels, *Eng. Fail. Anal.* 94 (2018).
- [11] Japan Road Association. Fatigue design guidelines for steel highway bridges, Tokyo; 2002.
- [12] P. Haagensen, S. Maddox, IIW recommendations on post weld improvement of steel and aluminium, *IIW Doc 13* (2003).
- [13] G.B. Marquis, E. Mikkola, H.C. Yildirim, Z. Barsoum, Fatigue strength improvement of steel structures by high-frequency mechanical impact: proposed fatigue assessment guidelines, *Welding World* 57 (6) (2013) 803–822.
- [14] K. Ghahremani, M. Safa, J. Yeung, S. Walbridge, C. Haas, S. Dubois, Quality assurance for high-frequency mechanical impact (HFMI) treatment of welds using handheld 3d laser scanning technology, *Welding World* 59 (3) (2015) 391–400.
- [15] G. Le Quilliec, H.P. Lieurade, M. Bousseau, M. Drissi-Habti, G. Inglebert, P. Macquet, L. Jubin, Fatigue behavior of welded joints treated by high frequency hammer peening: Part i, experimental study, 64th Annual Assembly & International Conference of the International Institute of Welding, (2011).
- [16] H. Yildirim, G.B. Marquis, Fatigue strength improvement factors for high strength steel welded joints treated by high frequency mechanical impact, *Int. J. Fatigue* 44 (2012) 168–176.
- [17] I. Lotsberg, A. Fjeldstad, M.R. Helsem, N. Oma, Fatigue life improvement of welded doubling plates by grinding and ultrasonic peening, *Welding World* 58 (6) (2014) 819–830.
- [18] H.C. Yildirim, Review of fatigue data for welds improved by tungsten inert gas dressing, *Int. J. Fatigue* 79 (2015) 36–45.
- [19] T. Skriko, M. Ghafouri, T. Björk, Fatigue strength of TIG-dressed ultrahigh-strength steel fillet weld joints at high stress ratio, *Int. J. Fatigue* 94 (2017) 110–120.
- [20] L.C. Wu, D.P. Wang, Improve the fatigue performance of welded joints with undercuts by TIG dressing treatment, *Adv. Mater. Res.* 472 (2012) 1300–1304.
- [21] H. Al-Karawi, A. Manai, M. Al-Emrani, A Literature review for the state of the art: Fatigue life extension of welded structures by peening and TIG dressing, report, Chalmers University of Technology, 2019.
- [22] S.H.J. Van Es, M.H. Kolstein, R.J.M. Pijpers, F.S.K. Bijlaard, TIG dressing of high strength steel butt welded connections- part 1: weld toe geometry and local hardness, *Procedia Eng. Fatigue Des.* 66 (2013) 216–225.
- [23] C.M. Branco, S.J. Maddox, V. Infante, E.C. Gomes, Fatigue performance of TIG and plasma welds in thin section, *Int. J. Fatigue* 22 (1999) 589–602.
- [24] L.L. Martinez, R. Lin, D. Wang, A.F. Blom, Investigation of residual stress in as welded and TIG-Dressed specimens subjected to statistic/spectrum loading, Proceedings of north European Engineering and science conference (NESCO): Welding high- strength steel structures, Stockholm-Sweden, 1997.
- [25] H. Yildirim, Review of fatigue data for welds improved by tungsten inert gas dressing, *Int. J. Fatigue* 29 (2015) 36–45.
- [26] A.L. Ramalho, J.A. Ferreira, C.A. Branco, Fatigue behavior of T welded joints rehabilitated by tungsten inert gas and plasma dressing, *Mater. Des.* 32 (10) (2011) 4705–4713.
- [27] J.W. Fisher, A.W. Pense, R.E. Slockbower, H. Hausammann, Retrofitting fatigue damaged bridges, *Transp. Res. Rec. no. 664* (1978).
- [28] C. Miki, T. Mori, S. Tuda, K. Sakamoto, Retrofitting fatigue-cracked joints by TIG arc remelting, *Doboku Gakkai Ronbunshu no. 380* (1987) 111–119.
- [29] A. Manai, F. Von Bock, J.H. Polach, A methodology for assessment and retrofitting by TIG dressing of existing pre-fatigued welded steel joints, 10th International conference on Bridge Maintenance, Safety and management, (2020).
- [30] A. Hobbacher, et al., Recommendations for fatigue design of welded joints and components, Springer, 2009.
- [31] F. Wolfgang, Recommendation for the fatigue assessment of welded structures by notch stress analysis, International Institute of Welding (2006), IIW.
- [32] A. Manai, R. U. F. von Bock und Polach, M. Al-Emrani, probabilistic study of welding residual stress distribution and their contribution to the fatigue life. *Engineering Failure Analysis*, EFA.104787, 2020, <https://doi.org/10.1016/j.engfailanal.2020.104787>.
- [33] Eurocodes, NF EN 1993-1-9 “Calcul des structures en acier - Partie 1-9 : Fatigue”.
- [34] P.C. Paris, F.A. Erdogan, A critical analysis of crack propagation laws, *J. Basic Eng.* (1963).
- [35] I.M. Austen, An analysis of the applicability of empirical fatigue crack growth relationships, BSC Research Report SH/PT/6795/79/B, British Steel Corporation,

- London, 1976.
- [36] P.E. Irving, L.N. McCartney, Prediction of fatigue crack growth rates: theory, mechanisms and experimental results, *Metal. Sci.* 11 (8/9) (1977) 351–436.
 - [37] R.G. Forman, Study of fatigue crack initiation from flaws using fracture mechanics theory, *Eng. Fract. Mech.* 4 (2003) no.2.
 - [38] S. Jaap, Fatigue prediction of welded joints and the effective notch stress concept, *Int. J. Fatigue* 45 (2012) 31–38.
 - [39] D.S. Forsyth, H.T. Yolken, G.A. Matzkanin, A brief introduction to non-destructive testing, *AMMTIAC* 1 (2) (2006) 7e10.
 - [40] Y. Kawakam, H. Hidesada Kanaji, K. Oku, Study on application of field signature method (FSM) to fatigue crack monitoring on steel bridges, *Procedia Eng.* 14 (2011) 1059e64.
 - [41] G. Ersdal, J.V. Sharp, D. Galbraith, Ageing accidents e suggestions for a definition and examples from damaged platforms, In: *Proceedings of the 33rd international conference on offshore mechanics and arctic engineering, San Francisco, California, (2014).*
 - [42] Wintle J, Sharp J. Requirements for life extension of ageing offshore production installations. For Petroleum Safety Authority. TWI report 17554/1/08. 2008.
 - [43] P. Hokstad, S. Håbrekke, R. Johnsen, S. Sangesland, Ageing and extension for offshore facilities in general and for specific systems, *SINTEF Technology and Society, Norway, 2010.*
 - [45] Morrow, J. Fatigue Design Handbook, *Advances in Engineering, Vol. 4, Society of Automotive Engineers (Philadelphia).* (1968).
 - [46] Fisher J. W., Pense, A. W., Slockbower R. E., Retrofitting fatigue damaged cover-plated bridge members, for presentation at the 1978 annual meeting of the TRB, 1978, annual meeting of the TRB. Fritz Laboratory Reports. (1978).