



On-line Voltage Instability Prediction using an Artificial Neural Network

Downloaded from: <https://research.chalmers.se>, 2026-04-04 14:42 UTC

Citation for the original published paper (version of record):

Hagmar, H., Le, A., Carlson, O. et al (2019). On-line Voltage Instability Prediction using an Artificial Neural Network. 2019 IEEE Milan PowerTech, PowerTech 2019.
<http://dx.doi.org/10.1109/PTC.2019.8810808>

N.B. When citing this work, cite the original published paper.

© 2019 IEEE. Personal use of this material is permitted. Permission from IEEE must be obtained for all other uses, in any current or future media, including reprinting/republishing this material for advertising or promotional purposes, or reuse of any copyrighted component of this work in other works.

On-line Voltage Instability Prediction using an Artificial Neural Network

Hannes Hagmar, Le Anh Tuan, Ola Carlson
Department of Electrical Engineering
Chalmers University of Technology
Gothenburg, Sweden
hannes.hagmar@chalmers.se

Robert Eriksson
Market and System Development
Svenska Kraftnät
Sundbyberg, Sweden
robert.eriksson@svk.se

Abstract—In this paper, a predictive method to detect voltage instability using an artificial neural network is presented. The proposed method allows transmission system operators to predict long-term voltage instability far before the system voltage stability has been degraded, allowing swift and cost-effective control actions. The predictor is tested and trained on the Nordic32 test system for a wide range of different contingencies. The predictor proves to be accurate in providing early warnings of impending voltage instability, allowing 96.3 % of all test cases being correctly classified only seconds after a contingency. The method is proposed to be used as an effective tool for supplementary voltage instability detection for transmission system operators.

Index Terms—Voltage instability prediction, artificial neural networks, voltage stability, synchronized phasor measurements, emergency control

I. INTRODUCTION

Ensuring and maintaining voltage stability are challenges that transmission system operators (TSOs) continuously face in their daily activities. The ability for TSOs to act quickly and with the correct control measures is imperative during an event causing voltage instability. Due to equipment in electric power systems, such as overexcitation limiters (OELs), load tap changing transformers (LTCs), and other load restoration dynamics, the time frame of a typical voltage collapse can range from a few seconds up to even a couple of minutes [1].

In the literature, there has been a significant development of different kinds of voltage stability indices (VSIs) suitable for real time assessment [2]. In general, VSIs aimed for *preventive applications* calculate stability margins and precontingency security limits ensuring that the system can handle a credible set of contingencies, thus meeting the N-1 stability criterion [2]. VSIs aimed for *corrective applications* are instead used for voltage instability detection (VID) and they are intended to be used when a contingency has occurred or if the system has drifted close to the instability region, allowing TSOs to as soon as possible detect an impending voltage collapse.

Machine learning (ML) has for several years been proposed to be used in the field of voltage stability assessment. One of the major advantages of using ML in voltage stability assessment is that high effort computations and training of the algorithm can be performed off-line, allowing almost instantaneous estimations once the algorithm is trained. In for example [3] and [4], ML algorithms are used to allow accurate

estimation of the N-1 voltage stability margins in real-time. Using conventional methods for estimating voltage stability margins will require a high computational effort, resulting in the estimations not being possible to perform in real-time. In an other paper [5], ML techniques are used for VID, where accurate although more time consuming VSIs can be computed in real-time, allowing more accurate detection of voltage instability than using other more simplified VSIs.

In case the preventive VSIs fails, or larger contingencies in the system occurs, the TSOs have to rely on corrective VSIs. For most corrective VSIs presented in the literature, the aim is to, as soon as possible, detect *when* the system has become unstable. However, when instability is detected, the system is often already severely degraded and the time until a voltage collapse may be either too short for TSOs to act, or the related costs with controlling the system back into stable operation may have significantly increased.

The evolution of a typical bus voltage at a transmission bus is illustrated in Fig. 1 for different severity of contingencies. For the case leading to a system collapse, the voltage instability is gradually developed, driven by components such as LTCs and OELs. At some point, the mechanism of load power restoration has caused the system to deteriorate to such a point that the total total power consumed in the system is reduced instead of restored [1]. Thus, Fig. 1 illustrates the problem of VID: that when the system stability has started to degrade, it evolves quickly and the time for TSOs to react and control the system back into stable operation is highly limited.

The most optimal VID method should allow prediction of voltage instability instantaneously after a contingency has occurred. That would allow TSOs to, directly after a contingency, get a notification whether the system is under too large stress and allow quick and effective control responses to steer the system back into stable operation. An early prediction method based on that approach was presented in [6], where a decision tree (DT) approach was used to predict unstable situations, just after a disturbance. The decision tree approach has been further developed in several papers, such as in [7]–[9].

However, despite the fact DTs are both intuitive and easily interpreted, the accuracy is generally not the highest of all ML algorithms. Artificial neural networks (ANNs) are not new in VIP [10]–[12], but their advantages have been reduced by large

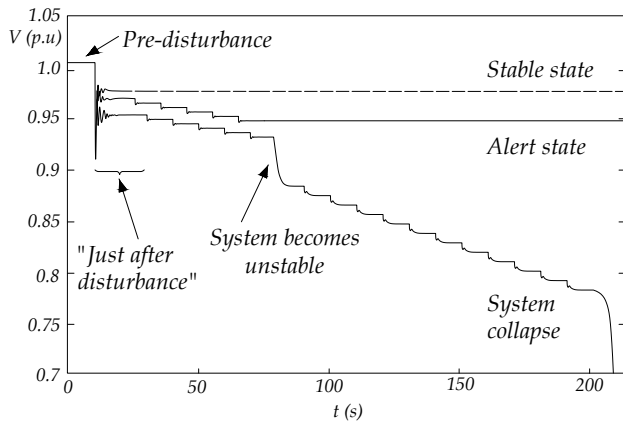

Fig. 1. Evolution of a voltage collapse for different contingencies

requirements of training data. Due to the rapid development of computational power, the popularity of using ANNs in various applications has increased significantly in the last decade [13]. Although generally requiring more training data, they should theoretically allow more accurate modeling of arbitrary non-linear functions, resulting in a higher accuracy of the classification, provided that sufficient data is available.

This paper develops a new approach of voltage instability prediction using a single hidden layer feedforward ANN. The method, in this paper denoted as the on-line voltage instability prediction method (O-VIP), will allow TSOs to not only predict voltage instability, but also to pinpoint *where* the weakest areas in the system are located, allowing local and more cost-effective control measures. Further, the paper suggests suitable parameters and input data for the architecture and training of the ANN, and provides a procedure to generate the training data using the dynamic simulations.

The paper is organized as follows. In Section II, the proposed method is presented along with the relevant theory and the steps of developing the training data and the training of the ANN. In Section III, the results of the method is presented. Section IV discusses possible applications and practical aspects, while concluding remarks are presented in section V.

II. METHOD FOR ON-LINE PREDICTIVE VOLTAGE INSTABILITY DETECTION

The O-VIP is based on performing off-line training of an ANN with the aim to, within only a few seconds after a disturbance, be able to predict whether that disturbance is going to cause a voltage collapse in the near future. The method is based on the notion that it is possible to deduct, from measuring the system states just after a disturbance, whether the system will end up being stable, in an alert state, or cause a system collapse. Due to the dynamics of voltage instability (mainly caused by OELs, LTC, etc.), the system may appear to be in a stable condition for a rather long time before a more rapid degradation of the system stability occurs.

A. ANN overview

Feedforward ANNs, also known as multilayer perceptrons, are the foundation of deep learning methods [13]. The strength

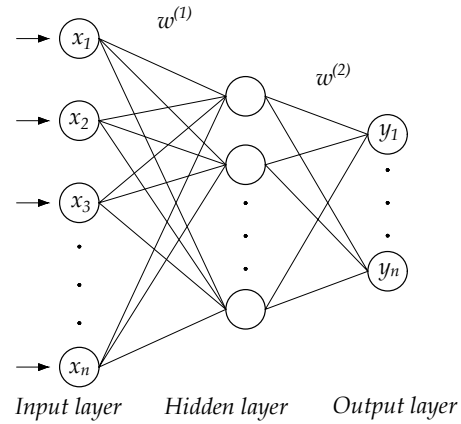

Fig. 2. Architecture of an ANN with a single layer of hidden neurons

of these methods, from here on denoted as ANNs, lies in their capability of accurately learning and approximating non-linear functions (f^*) from a set of training data without requiring any prior information. Thus, from a set of inputs (x_n) and corresponding target values (y_n) the ANN is capable of estimating the weights (w), or the parameters, mapping the inputs to the target values.

In Fig. 2, the structure of an ANN with a single layer of hidden units is presented. Between each layer there is a set of weights ($w^{(1)}$ & $w^{(2)}$) connecting each node in the system. A deeper architecture, i.e. more layers with hidden units, is often used in applications with more complicated functions and input-output mappings. Each of the nodes in the hidden layer consists of activation functions, such as the sigmoid-function or the rectified linear unit-function, simulating the response of real neurons in the human brain.

The learning of the ANN is performed using an algorithm called backpropagation, which iteratively adjusts the weights between each node and layer based on the adjustments that minimizes a cost function. The cost function is defined as the error between the estimated output and the actual target value. Once either the cost function has been minimized, or other stopping criteria has been met (for example maximum number of iterations reached), the ANN is fully trained.

B. Generating training data

The simulated system in this paper is the Nordic32 test system which has been tested and used in several previous voltage stability simulations [14]. The method is based on generating a large set of data using dynamical simulations, which will be the training base for the ANN. The steps of the method is illustrated as a flowchart in Fig. 3 and can be summarized as follows:

- 1) *Randomly chosen power flows*: To simulate a large number of possible power flow states in the system, the system power flows are randomly initiated. For these simulations, the loads are first randomly chosen from a uniform distribution around the original loads (90 % of original load as lower limit, 105 % of load as upper limit). The change in load is then distributed randomly among all the

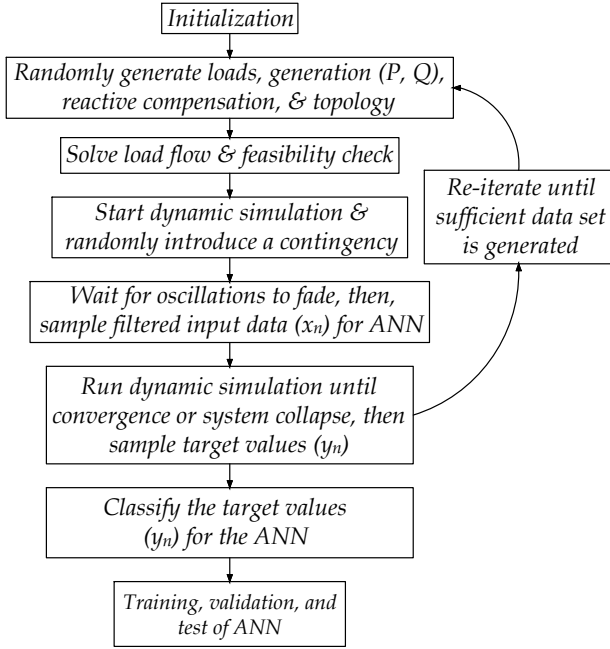

Fig. 3. Flowchart of the procedure of generating data and training the ANN

generators in the system. More configurations are possible, for instance, different levels of reactive compensation and different topologies, but this is not simulated in this paper. All power flow calculations and the dynamical moderation simulations in this paper are performed using PSS®E version 34.2.0 with its in-built dynamical models [15].

- 2) *Solve and check for feasibility*: The randomly generated system is solved with a power flow simulator, which serves as a starting point for the dynamical simulation. If the load flow does not converge, the initial operating condition is re-initialized.
- 3) *Start dynamic simulation and introduce contingency*: A dynamic simulation is then started, including all relevant dynamic models of the system. For the simulations in this paper, only line faults are examined. To illustrate a possible contingency, a line fault is applied for 0.1 s, which is then cleared by tripping the faulted line. Any of the lines in the Nordic32 system is randomly chosen for the contingency.
- 4) *Sample inputs x_n for the ANN*: Before the inputs to the ANN is sampled, the initial oscillations caused by the fault should be allowed to dissipate. If not, the inputs may be inconclusive and cause a more uncertain classification of the system state. To reduce the impact of small oscillations, the inputs are filtered using the mean value of three different samples registered with a few seconds interval 10 seconds after the fault is cleared.
- 5) *Run until convergence or collapse*: The dynamic simulation is then continued, and runs either until the system converges or crashes. The transmission bus voltage magnitudes are then sampled as a base for generating the target values/classification of the different cases.
- 6) *Classification of data*: The data is classified into different

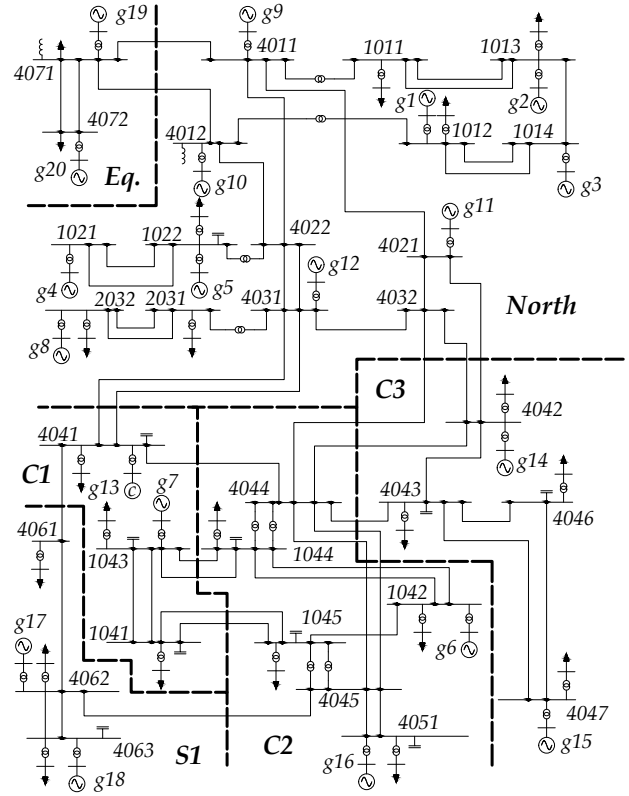

Fig. 4. One-line diagram of Nordic32 test system with new subareas

categories according to the severity and location of the system degradation. The system stability is defined as stable if all transmission bus voltage magnitudes in the system are above 0.95, in an alert state if any transmission bus voltage magnitude ranges between 0.9 - 0.95 pu, and in an emergency state if any transmission bus voltage magnitude is below 0.9 pu:

$$\text{Stable} : |V_{mag}| \geq 0.95pu$$

$$\text{Alert} : 0.9 \leq |V_{mag}| \leq 0.95pu$$

$$\text{Emergency} : |V_{mag}| \leq 0.9pu$$

The cases are also classified according to *where* in the system the lowest bus voltage magnitude is found at the end of the performed dynamic simulation. The Nordic32 system has therefore been divided into different regions, as illustrated in Fig. 4. The regions "North" and "Eq." are more stable regions and no alert events nor emergency events were found in these regions for any of the simulated cases. Thus, for the classification, only the other four regions (C1, C2, C3, S1) were used. The classification for each of the simulations belongs consequently to one of 9 different classes: either the whole system is stable or, an alert or an emergency state is identified in one of the four regions where the lowest occurring transmission bus voltage is identified. The classification is further illustrated in the result section in Table I.

- 7) *Re-iterate until sufficient data set is generated*: The steps

should be reiterated and the inputs and target values should be saved until a sufficient data set is generated. The required amount of data is highly dependent on the range of possible states in the system and the number of different contingencies being taken under consideration. A more thorough discussion regarding the need of a large data set is given in section IV.

C. Training and architecture of the ANN

Once a sufficient amount of training data is generated, the ANN is trained. For the results in this paper, an ANN with a single layer of hidden neurons is used, developed in the MATLAB Neural Network Toolbox [16]. The optimization is performed using the scaled conjugate gradient backpropagation. The training was terminated when either a maximum of 1000 epochs was reached, the training mean-squared error falls below $1e-6$, or until 10 validation checks are performed. A validation check is given when the validation performance fails to decrease, which is a method to avoid overfitting.

To find the best combinations of inputs to the ANN, 5 different input features sets are tested. These cases include:

- Case 1: Voltage mag.
- Case 2: Voltage mag. & generated power (P & Q)
- Case 3: Voltage mag. & phase angle
- Case 4: Voltage mag., P & Q branch flow
- Case 5: Voltage mag., P & Q branch flow & phase angle

A total of 100 000 dynamical simulation samples are generated for each feature set. The data is divided into an 80-10-10 % training, validation, and test set, respectively. The most appropriate number of hidden neurons with respect to accuracy, over-fitting, and computation time was found to be 16 hidden neurons. This number is based on the results presented in section III. Due to random sampling and different initializations of the weights in the ANN, the performance varies slightly when training the ANN multiple times. To find the lowest test error, the ANN was trained for a total of ten times, and only the best performance is presented in the paper.

III. SIMULATION RESULTS

A. Performance of the O-VIP

The lowest test error achieved in the simulations was 3.7 % using 16 neurons in the hidden layer and inputs according to case 4. In Table I, the classification test results are represented by a confusion matrix for case 4. Each column in the table represents instances of the predicted classes, and each row represents the instances of the actual classes. The total accuracy is presented in the lower right corner of the table.

According to the table, the accuracy of the O-VIP in the case of stable states is 96.2 %, and 3.8 % of all stable cases were thus misclassified to belong in the alert state. None of the actual stable states were classified as emergency states. All of the misclassification for the emergency states were either for other regions, or ended up being classified as an alert state but in the correct region. A 100 % accuracy was achieved for the classification of emergency state in S1, although only a

single sample were generated for this class. This region of the Nordic32 test system was thus significantly less prone to voltage instability compared to other regions. The lowest accuracy were for the alert state in S1, 85.2 %, where several samples were misclassified as being in a stable state.

It is likely that for a majority of all cases being misclassified as stable, although actually being in an alert state, the O-VIP would be able to classify these correctly if the measurement values were sampled a longer time after the contingency occurred, allowing the system to degrade slightly more. Hence, there exists a balance between a fast classification and accuracy. Specific threshold values could be applied such that only a certain amount of falsely positive classified cases are accepted, or that only classifications with a certain probability are accepted.

B. Choice of input features

Five different set of input feature combinations were tested to find the best suitable. The performance for each of the five cases are presented in Table II. The best performance is achieved for case 4, where the input data consists of bus voltage magnitudes and active and reactive branch flows. Thus, in contrast to what is presented in [4], the voltage magnitude and the phase angles do not present the best input to the ANN for this application. One explanation for this outcome could be the fact that during faults, the angle difference for certain buses may vary significantly depending on the actual contingency, providing somewhat inconclusive information to the ANN. Thus, if branch power flows are used instead of phase angles, the ANN is provided with more conclusive data and allows a better classification. Another advantage of using branch flow as inputs is that these provide information if a branch is out of service, as the flow always reduces to zero. In case phase angles are used, the ANN will have no indirect information that a certain branch is no longer in service.

For case 5, the error is somewhat larger than for case 4. It is an interesting result, since more input values should at least not increase the error. The probable main explanation is the impact of random sampling of the test set, different initializations of the weights, and that the network might slightly overfit on the training data.

C. Choice of neurons and training set size

The so-called hyperparameters of an ANN, such as the number of neurons in the hidden layer, or the depth of the network, control the learning of the algorithm and must be chosen before the actual learning process has begun. The design and choice of such parameters is often an iterative process, and will often have to be tuned and changed repeatedly in order to achieve a desirable performance. In the scope of this paper, the sensitivity of all available hyperparameters is not feasible to present, and the focus has instead been to examine a suitable number of neurons in the hidden layer and how the training set size affects the performance of the predictor.

TABLE I
PREDICTION RESULTS AND ACCURACY OF THE O-VIP ALGORITHM (CONFUSION TABLE)

Classification		Predicted states										Accuracy
		Stable state		Alert state				Emergency state				
		All areas	C1	C2	C3	S1	C1	C2	C3	S1		
Actual states	Stable state	All areas	4527	62	0	1	117	0	0	0	0	96.2%
	Alert state	C1	77	2359	1	0	6	1	13	0	0	96.0%
		C2	0	0	0	0	0	0	0	0	0	-
		C3	2	2	0	1268	0	0	0	4	0	99.4%
		S1	63	7	0	0	402	0	0	0	0	85.2%
	Emergency state	C1	0	0	0	0	0	1	0	0	0	100%
		C2	0	7	0	0	0	3	262	0	0	96.3%
		C3	0	0	0	3	0	0	0	83	0	96.5%
		S1	0	0	0	0	0	0	0	0	725	100%
	Accuracy		97.0%	96.8%	0%	99.7%	76.6%	20%	95.3%	95.4%	100%	96.3%

TABLE II
PERFORMANCE OF ANN WITH DIFFERENT INPUT FEATURE SETS

Feature case	Case 1	Case 2	Case 3	Case 4	Case 5
Test error [%]	5.0	4.4	4.7	3.7	4.0

1) Choosing number of neurons in hidden layer:

To find the most suitable number of neurons in the hidden layer, an iterative algorithm was adopted that trained the system with an increasing number of neurons. In Fig. 5, the training, validation, and test error for a range of different numbers of neurons in the hidden layer are presented for case 4. According to the figure, the test error decreases significantly with an increasing amount of neurons up until 16 neurons, where the lowest test error is found. By increasing the number of neurons even further, the test training error keeps decreasing, while both the validation and the test error are increasing, indicating an increased overfitting of the parameters. The suitable number of neurons are highly depending on the application and a different number of neurons for other sizes and configurations of grids is possibly more accurate.

2) *Impact of training data size:* The impact of a sufficiently large training set is illustrated in Fig. 6, where the training, validation, and test error is plotted for case 4, this time with an increasing amount of training data on the x-axis. Generally, an ANN increases its performance with an increasing amount of training data, up to a certain point when the performance converge. As can be seen in the figure, the test performance increases significantly with an increasing amount of data. However, as the training data approaches a larger value, the test error stabilizes at around 4 %.

The training error should converge to a value close zero with an increasing amount of data, given that the provided input values contains sufficient information to differentiate between the post-contingency states. Since this is not fully the case, it is likely that the provided input data is not sufficient to allow accurate classification in the more difficult cases. If other information, such as dynamic values and states of OELs and LTCs, could have been provided to the ANN, the harder cases could possibly be correctly classified as well.

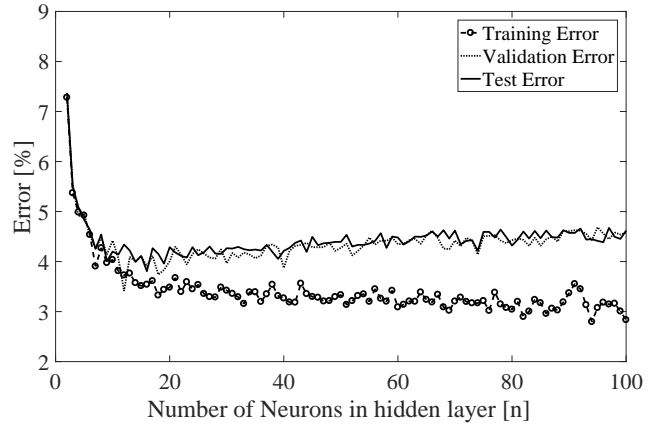

Fig. 5. Training, validation, and test error with varying number of neurons in hidden layer

The requirement of a large data set is also affected by the range of different pre-contingency load flows of the system and the set of credible contingencies taken into account. A system with minor variations in its configurations and its load flows would thus require a smaller set of training data than a system with large variations.

IV. APPLICATIONS AND LIMITATIONS

A. Applications and usefulness

The O-VIP could present a powerful tool for TSOs and it is proposed to mainly be used as a supplementary system and to act as a complement to other voltage instability warning systems. For the predictor to be effective, measurement updates should be available in the range of a few seconds (1-10 s), as otherwise too long time between the assessments would occur. Measurements from SCADA systems filtered through a conventional state estimator could thus be too slow to be effective, and preferably, the O-VIP would instead be based on measurements from wide-area phasor measurements, filtered through a (linear) state estimator.

The application can serve as a direct warning system to TSOs, allowing them time to perform suitable control measures to control the system back into stable operation. Alternatively, the application itself could be used to initiate

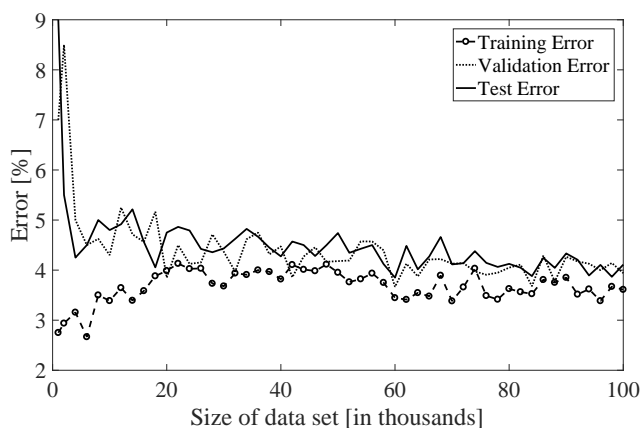

Fig. 6. Training, validation, and test error with varying data set size

system protection schemes to automatically restore stability to the system. Such automatic schemes would in most cases only be used after significant testing and most likely only for the detection and aversion of emergency states.

Another advantage of using an ANN is that it is highly suitable for on-line applications. Using training methods such as stochastic gradient descent, the ANN can gradually increase its performance as more training data is being generated. Connecting an on-line training scheme of the O-VIP with, for example, the SCADA system could allow the method to gradually increase its accuracy while ensuring that no changes in the system are neglected.

B. Measurement and model errors

The performance of any VSI will be affected by both measurement errors and by errors in the model that the VSI is based on. The trueness and precision of measurements in the power system is dependent on both the quality of measurement devices and the level of measurement redundancy in the system. A high level of measurement redundancy increases the accuracy of state estimation algorithms and reduces the impact of such errors significantly, which in turn would increase the accuracy of VID systems. However, it is most likely that the model errors that will affect the accuracy of the O-VIP the most. Not only has regular system parameters, such as line reactance and line resistance to be modeled accurately, but also each dynamic model in the system has to be modeled with sufficient accuracy. This includes modeling of parameters for OELs, time-steps for LTCs, time-delays in different relay equipment, and various load restoring systems. One of the greatest challenges is to *verify* that the O-VIP is in fact accurate. Voltage collapses, although a phenomenon that TSOs always have to plan and take into account, occurs very seldom. Hence, it would prove difficult to, in practice, test the system. Since such tests of the O-VIP would be difficult, the requirement of careful assessment of all different dynamic models in the system becomes increasingly important.

V. CONCLUSION

This paper presents a new approach for on-line prediction of voltage instability based on training an ANN. The results

presented in this paper is highly encouraging, showing high accuracy (96.3 %) of predicting whether a voltage collapse will develop, only seconds after a contingency in the system. The main benefits of the O-VIP are both the early prediction of voltage instability and the possibilities to pinpoint where in the system the instability is the most severe. This would allow earlier and more cost-effective control actions to steer the system back into stable operation again. The system can be applied and trained using on-line measurement data from the SCADA system, but for real-time detection of voltage instability, measurement from wide-area phasor measurements would be preferred. More studies should be performed regarding the impact of measurement and model errors and how that would affect the accuracy of the O-VIP.

ACKNOWLEDGMENT

The work presented in this paper has been financially supported by Energimyndigheten (Swedish Energy Agency) and Svenska kraftnät (Swedish National Grid) within the SamspeL program.

REFERENCES

- [1] T. Van Cutsem and C. Vournas, *Voltage stability of electric power systems*. Boston: Kluwer Academic Publishers, 1998.
- [2] M. Glavic and T. Van Cutsem, "A short survey of methods for voltage instability detection," in *Proc. (IEEE) PES General Meeting*, Detroit, MI, Jul 2011, pp. 1–8.
- [3] M. L. Scala, M. Trovato, and F. Torelli, "A neural network-based method for voltage security monitoring," *IEEE Trans. on Power Syst.*, vol. 11, no. 3, pp. 1332–1341, Aug 1996.
- [4] D. Q. Zhou, U. D. Annakkage, and A. D. Rajapakse, "Online monitoring of voltage stability margin using an artificial neural network," *IEEE Trans. on Power Syst.*, vol. 25, no. 3, pp. 1566–1574, Aug 2010.
- [5] G. G. Lage, R. A. S. Fernandes, and G. R. M. da Costa, "Neural-network representation of voltage stability indices at the voltage collapse," in *North American Power Symposium*, Aug 2011, pp. 1–7.
- [6] T. Van Cutsem *et al.*, "Decision tree approaches to voltage security assessment," *IEE Proceedings C - Generation, Transmission and Distribution*, vol. 140, no. 3, pp. 189–198, May 1993.
- [7] H. Khoshkhou and S. M. Shahrtash, "Fast online dynamic voltage instability prediction and voltage stability classification," *IET Generation, Transmission & Distribution*, vol. 8, no. 5, pp. 957–965, May 2014.
- [8] —, "On-line dynamic voltage instability prediction based on decision tree supported by a wide-area measurement system," *IET Generation, Transmission & Distribution*, vol. 6, no. 11, pp. 1143–1152, November 2012.
- [9] R. Diao *et al.*, "Decision tree-based online voltage security assessment using pmu measurements," *IEEE Trans. on Power Syst.*, vol. 24, no. 2, pp. 832–839, May 2009.
- [10] Q. Zhou, J. Davidson, and A. A. Fouad, "Application of artificial neural networks in power system security and vulnerability assessment," *IEEE Trans. Power Syst.*, vol. 9, no. 1, pp. 525–532, Feb 1994.
- [11] Y. Mansour *et al.*, "Large scale dynamic security screening and ranking using neural networks," *IEEE Trans. Power Syst.*, vol. 12, no. 2, pp. 954–960, May 1997.
- [12] —, "Large scale dynamic security screening and ranking using neural networks," *IEEE Trans. Power Syst.*, vol. 12, no. 2, pp. 954–960, May 1997.
- [13] I. Goodfellow, Y. Bengio, and A. Courville, *Deep Learning*. MIT Press, 2016, <http://www.deeplearningbook.org>.
- [14] M. Stubbe *et al.*, "Long term dynamics - phase II final report," Cigré Task Force, Tech. Rep. 38.02.08, Mar. 1995.
- [15] *PSS®E 34.2.0 Model Library*, Siemens Power Technologies International, Schenectady, NY, Apr. 2017.
- [16] M. H. Beale, M. T. Hagan, and H. B. Demuth, *Neural Network Toolbox™ User's Guide*, 1992.