

ARCHITECTURE'S POETIC INSTRUMENTALITY

Developing the Critical, Political, and Ethical Capacities
of Architectural Artifacts

JOHAN LIEKENS

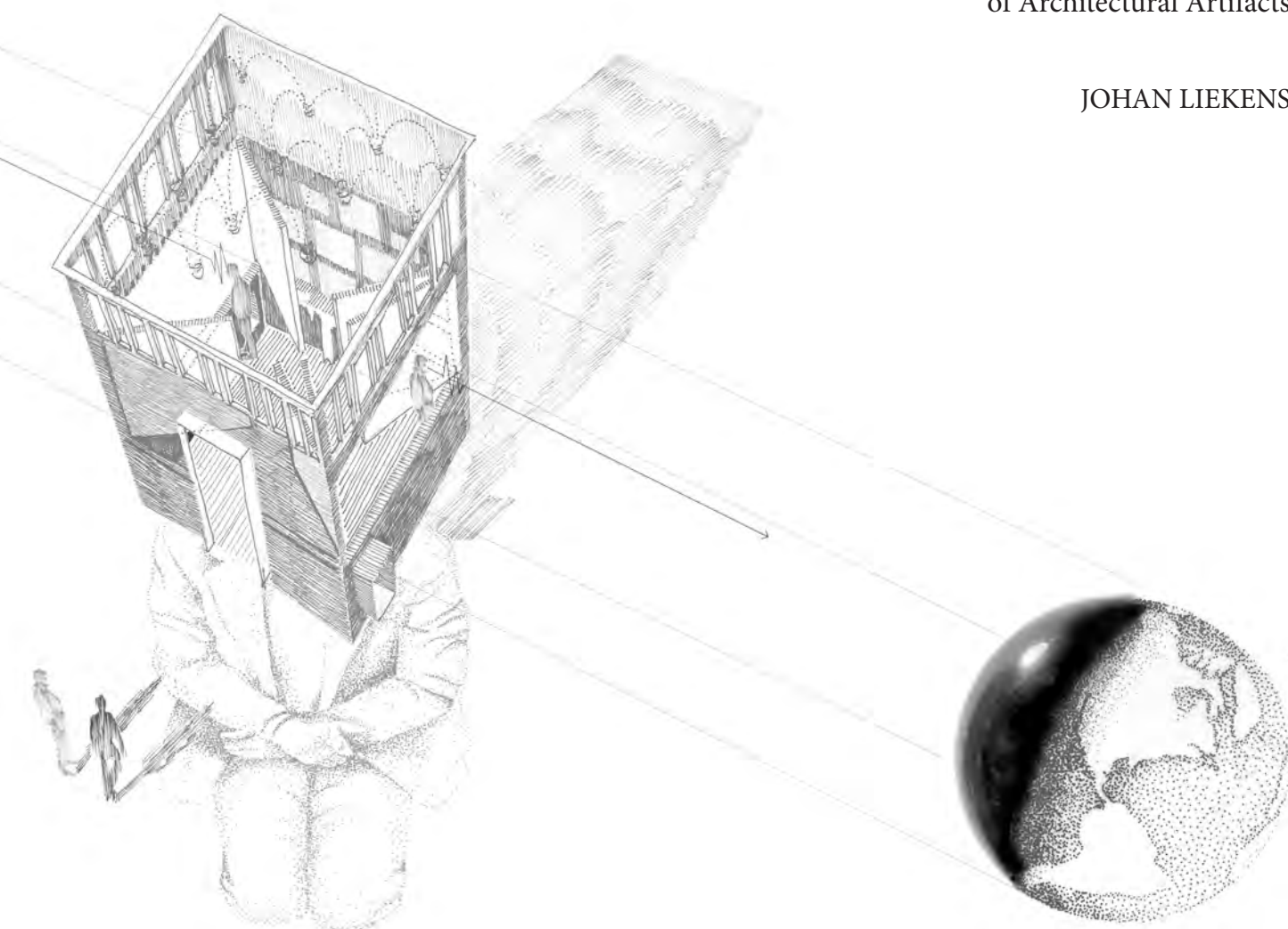

THESIS FOR THE DEGREE OF DOCTOR OF PHILOSOPHY

ARCHITECTURE'S POETIC INSTRUMENTALITY

Developing the Critical, Political, and Ethical Capacities of Architectural Artifacts

JOHAN LIEKENS



Department of Architecture and Civil Engineering
Institutionen för Arkitektur och Samhällsbyggnadsteknik

CHALMERS UNIVERSITY OF TECHNOLOGY

Gothenburg, Sweden 2020

and

Faculty of Architecture, Sint-Lucas campus
Faculteit Architectuur, campus Sint-Lucas

KU LEUVEN

Brussels - Ghent, Belgium 2020



ARCHITECTURE'S POETIC INSTRUMENTALITY

Developing the Critical, Political, and Ethical Capacities of Architectural Artifacts

Johan Liekens

ISBN 978-91-7905-220-1

© Johan Liekens, 2020.

All rights reserved.

No part of the publication may be reproduced in any form by print, photoprint, microfilm, electronic or any other means without written permission from the publisher.

Doktorsavhandlingar vid Chalmers tekniska högskola

Ny serie nr 4687

ISSN 0346-718X

Department of Architecture and Civil Engineering

Chalmers University of Technology

SE-412 96 Gothenburg

Sweden

Telephone + 46 (0)31-772 1000

KU Leuven identification number:

doctoral dissertation n° 2020/3E150268

Faculty of Architecture

KU Leuven

Sint-Lucas campus Ghent-Brussels

Belgium

Telephone +32 (0)2 447 19 00

Language revision:

John Krause Language Consulting

3410 N Lake Shore Dr 17E, Chicago, IL 60657, USA

Cover images:

Main image front and back cover:

People-Architectural artifact-World(s): Johan Liekens.

Secondary images front cover:

fig. a, b, c, d: Johan Liekens, fig. e: Stijn Bollaert.

Secondary images back cover:

fig. f and g: Johan Liekens

Chalmers Reproservice

Gothenburg, Sweden 2020

★_

ABSTRACT

The PhD thesis *Architecture's Poetic Instrumentality* is rooted in and driven by an enthusiasm of architectural practice—an enthusiasm for conceiving, constructing and deploying architectural artifacts that, as *poetic instruments*, intend to have an *agency* within urban environments. The title puts in tension the two notions of *instrument* and *poesis* (from the Greek *poiesis*, referring to a *making* activity but moreover to an activity of *making up*, situated here in those encountering architecture). Preparing the architectural artifact as a *poetic instrument* then puts the partly contingent adventures it helps affording at the center of the inquiry.

Poesis, as an activity of *making up*, of *sense-making*, and *agency*, as a dynamic able to invoke such acts of *poesis*, are considered in this thesis as endowed with a transformative potential. They explicitly bring into scope the realm of architectural reception: the many uses, appropriations, occupations, and negotiations of architecture. In order to explore such *poesis* and *agency*, a variety of architectural artifacts have been developed within the time span of the research, spread across different collaborations. These artifacts propel the research, giving particular substance to the main methodological approach, that of *research-through-practice*.

The exploration of a *poetic instrumentality* has been pursued through an exploration of architecture's capacity to act *critically*, *politically*, and *ethically within situations*. Such capacity is often, according to a variety of contemporary authors, atrophied or at least left partly unaddressed. Answering calls to re-activate architecture in that sense, this research aims to substantiate contributions that can help counter this deficit. It does so through edifying a heterogeneous set of architectural artifacts, developed as well as deployed within real urban surroundings and situations, working as acupuncture-like interventions. The research also develops a set of approaches, strategies, and attitudes. The audience is multiple as both those professionally practicing and conceiving of architecture as well as those practicing architecture through encountering it within daily situations are targeted.

Architecture's Poetic Instrumentality is edified on two main experimenting grounds. One is the educational design studio COMplicating MACHines / COMplicating INteriors, the other the architecture firm STUDIOLoarchitectuur. Each advances a differently constrained terrain for experimentation, raising different challenges, assembling different contributions. What links the experimenting on both grounds together and characterizes all artifacts of the research is that they all seek to include dynamics often neglected in architecture: *critical*, *political*, and *ethical* dynamics; dynamics of *projectivity*, *negotiation*, *conflict*, *dissensus*, *agonism*; para-functional dynamics. Substantiating this inclusion has led to an *other* kind of architectural artifacts and to *other ways of doing architecture*, conceived not as an alternative to architecture, but as a promise and capacity that fundamentally reside *within* architecture and its artifacts.

keywords:

critical architecture;
political architecture;
ethical architecture;
architectural agency;
agonistic staging;
dynamics of dissensus.

main supervisors (double degree program):

Professor Fredrik Nilsson,
Chalmers University of Technology,
Department of Architecture and Civil Engineering;
Professor Yves Schoonjans,
KU Leuven Faculty of Architecture, Sint-Lucas campus.

examiner:

Professor Fredrik Nilsson,
Chalmers University of Technology,
Department of Architecture and Civil Engineering.

assessor:

Professor Nel Janssens,
KU Leuven Faculty of Architecture, Sint-Lucas campus.

faculty opponent:

Professor Tatjana Schneider,
GTAS Technische Universität Braunschweig.

examination committee:

Professor Ramia Mazé,
Department of Design, Aalto University;
Professor Fredie Floré,
KU Leuven Faculty of Architecture, Sint-Lucas campus;
Professor Peter Ullmark, KTH /
Chalmers University of Technology,
Department of Architecture and Civil Engineering.



Figure b: the vivid stage of my research project. Drawing: Johan Liekens.

★_ ACKNOWLEDGEMENTS

My thesis project has been developed in a double degree research collaboration between the KU Leuven Faculty of Architecture, Sint-Lucas campus, and the Chalmers University of Technology, Department of Architecture and Civil Engineering. It has been facilitated by both in many ways. For financial support in the form of precious time I received to undertake this adventure, I wish to express my gratitude to the KU Leuven Faculty of Architecture and its dean Dag Boutsen, and to its former head of department Johan Verbeke. The latter has played an important role in setting up the research environment that has been a substrate for this project. In the light of granting me time, I also wish to thank Yves Schoonjans in his former role of vice-dean of research and Carl Bourgeois in his role of vice-dean of education. Similarly, I am thankful for the extraordinary northern generosity and support I have experienced through my Gothenburg affiliation.

Having also taken other forms, my project has substantiated in architectural artifacts, intended as vivid stages. In similar ways I think of this thesis. Without the multifarious acts of debating, negotiating, appropriating and sense-making performed by many others and by many authors on the stage that is this research project, it would not exist. I wish to thank each and every one who has connected in one way or another to it. One way is not necessarily more important than another, and no sequence is strict. However, allow me to make more specifically present some of the people gathering on the stage that is *Architecture's Poetic Instrumentality*.

I salute the group of people who has intensively guided me. To my main supervisors, Fredrik Nilsson and Yves Schoonjans, you have promoted my work, entailing all that is included in the term pro-motion. Fredrik, throughout the many bright as light interventions you performed, you helped propel and challenged this project from the outset. Besides this, it is how you are a researcher I have appreciated: ultimately generous, always humanly ethical. Qualities that are worth mirroring. Because of you, I came to taste the Swedish and some of the other northern research milieus. The ResArc courses and Strong Research Environments you helped bring into life have been important in gathering some of the voices resonating on this stage here, voices of researchers as well as researchers in the making. In these northern contexts, I wish to thank also Catharina Dyrssen and Halina Dunin-Woyseth, who have both been ultimately important to this research. All together we had great talks, but also great laughs.

An architect and friend of you, Yves, once told me he took important decisions pacing through Ghent's botanical garden Hortus Michel Thiery, a stone's throw away from my study desk. Leaned against its unique and impressive *Populus x Canadensis Marilandica*, I first thought of involving you in the project. It was a good decision. I thank you specifically for the regular conversations we had, and the support you materialized for me. These conversations had a qualitative assembled nature: one given Thursday, your studiolo, a hand on my text, a hand in princess' Leia's insubordinate dog-hairs, eyes wondering through the multitude of collected *curiosa*, our thoughts.

I wish to thank Nel Janssens, who has taken the role of assessor in my research. You have been a force. I thank you for caring for this research project. I also specifically thank you for inviting me into the research groups you helped constitute at KU Leuven's Faculty of Architecture, their rich contexts and contents I am now part of. I thank Thierry Berlemont, Arnaud Hendrickx, Wim Goossens, Hanne Van Den Biesen, Sam Dieltjens, Eva Gheysen, Gerlinde Verhaeghe, and the other members of the Radical Materiality research group for their insights and help, not at least provided through their own work. Similarly, I thank Laurens Luyten and Annelies De Smet, looking forward to new research adventures tied to the Wicked Matters research group. I also thank Marc Godts, still present in these groups.

My gratitude also goes to Peter De Graeve and Freddie Floré, who have examined my research at intermediate stages. I

wish to thank my examination committee Ramia Mazé, Freddie Floré, and Peter Ullmark for carefully examining my research in its end phase. I thank Tatjana Schneider for critiques in her role as faculty opponent, which have been and will be important to bring my research one step further.

I thank Gerard De Zeeuw, Rolf Hughes, and Alain Findeli for valuable insights gained on route.

I move the focus to another group on the stage now, people who have influenced its course in a variety of other ways. I thank Stefaan Onraet for what seems to be a lifetime of interior adventures. He has been an exceptional Head of the Master of Interior Architecture program at KU Leuven Faculty of Architecture. I hope retirement age in Belgium will be suspended indefinitely; Klaas Vanslebrouck, a listening ear in this project, for precious walks and talks and for lending me his house and dog from time to time; Sanne Delecluyse, Lieslot Bleyaert and Jolien Gorris of STUDIOLoarchitectuur for current adventures in architecture, and Sigyn De Lombaerde and Koen Matthys for previous ones, which all helped to ground this research; Steven Graauwmans for sharing trips to Gothenburg, and for some deviant words from time to time; Seppe Geuens, Dries and Willem De Loore for co-crafting material adventures; Brady Burroughs, Sepideh Karami, Ida Sandström, Lucia D'Errico, and Luc Nijs, for common and imaginative adventures undertaken as students in research; those who have travelled and will travel to support me and the project on a variety of occasions. I thank the multitude of students of the design studio COMplicating MACHINES / COMplicating INTERiors and colleagues such as Karel Deckers and Eva Gheysen for sharing time in helping to establish this studio. Here, I specifically thank Marie-France Lebbe and Sanne Delecluyse for interesting conversations on and evaluations of the studio. I thank Mirte Van Aalst for her help some afternoons when burning and cladding the façade of the Research Studiolo.

I thank my family for sympathizing. I have never had the formal opportunity to express gratitude and admiration for my mother's assistance in crafting architectural models during my studies as an architect. Here I seize the opportunity to do so. Thank you for your endurance. You were great!

Betelgeuze will soon light up the sky, they say. A bright beacon over the stage that is my research has been Karolien Vanmerhaeghe. You are STUDIOLoarchitectuur's spinning rotor, endowed with a myriad of skills and talents you have also surrounded my research with whenever necessary. For companionship in life and work, and for believing in me in this project I am thankful.

Johan Liekens,
Ghent, 2020

<p>INTRODUCTORY 2</p> <p style="text-align: center;">CHAPTER</p>	<p>★_1.</p> <p>AN ENTHUSIASM OF ARCHITECTURAL ARTIFACTS MAKING WONDER</p> <p>4 1.1. BACKGROUND OF THE RESEARCHER: A SET OF ARCHITECTURAL PRACTICES</p> <p>12 1.2. PROBLEM AND CHALLENGE</p> <p>18 ★_2.</p> <p>METHODOLOGICAL POSITIONING</p> <p>18 2.1. A RESEARCH-THROUGH-PRACTICE APPROACH: MAKING ARCHITECTURE AS A METHOD</p> <p>27 2.2. DIAGRAMMING DESIGN RESEARCH</p> <p>28 2.2.1. <i>Groat and Wang's nested set of levels positioning design research</i></p> <p>31 2.2.2. <i>Daniel Fallman's triangle of design practice, design exploration, and design studies</i></p> <p>36 ★_3.</p> <p>METHODOLOGICAL POSITIONING, IN A NUTSHELL</p>
<p>CHAPTER 1 40</p> <p style="text-align: center;"><i>exploring</i></p> <p><i>a critical, political, and ethical capacity</i></p> <p style="text-align: center;"><i>of architectural artifacts</i></p> <p><i>in the experimenting ground of the</i></p> <p style="text-align: center;">CoMa/CoIn</p> <p style="text-align: center;">DESIGN STUDIO</p>	<p>★_4.</p> <p>EXPLORING A CRITICAL CAPACITY OF ARCHITECTURAL ARTIFACTS</p> <p>40 4.1. AN ENCOUNTER WITH cOmA₀₁</p> <p>50 4.2. TRACING A CRITICAL CAPACITY OF ARTIFACTS IN CRITICAL DESIGN</p> <p>50 4.2.1. <i>para-functionality and aesthetics of use</i></p> <p>55 4.2.2. <i>poeticizing distances and gaps</i></p> <p>57 4.2.3. <i>tactile clue-ing</i></p> <p>59 4.3. TRACING A CRITICAL CAPACITY OF ARTIFACTS IN CRITICAL ARCHITECTURE</p> <p>59 4.3.1. <i>a shared stance with critical theory</i></p> <p>61 4.3.2. <i>a hint at the political, but a moralizing one</i></p> <p>61 4.3.3. <i>other critiques of critical theory</i></p> <p>62 4.3.4. <i>divergent notions of critical architecture</i></p> <p>63 4.3.5. <i>towards a critical, political and ethical projective-ness of architectural artifacts</i></p> <p>66 ★_5.</p> <p>EXPLORING A POLITICAL CAPACITY OF ARCHITECTURAL ARTIFACTS</p> <p>68 5.1. AN ENCOUNTER WITH c0mA₀₂</p> <p>74 5.2. cOMa/cOiN: A PRACTICE WITHIN THE ENIGMATIC CONJUNCTION [URBAN + INTERIOR]</p> <p>74 5.2.1. <i>[urban+interior]:</i> <i>the porous relationship between urban and interior</i></p> <p>76 5.2.2. <i>[urban+interior]: always an in-the-making / on project and projective-ness</i></p> <p>76 <i>_a sense in-the-making, a political urban poesis and an assembled thick urbanism_</i></p> <p>79 <i>_the morphogenesis in the encounter_</i></p> <p>82 <i>_who makes (in) the encounter_</i></p> <p>83 5.2.3. <i>[urban+interior]: a model of participatory making (!)(?)</i></p> <p>84 5.2.4. <i>[urban+interior]: always a question of in-habitability and the inhabiting of worlds</i></p> <p>85 5.2.5. <i>[urban+interior]: knowledge in the encounter</i></p> <p>88 5.2.6. <i>[urban+interior]: urban articulations that temporally de- and re-territorialize knowledge</i></p> <p>89 5.3. cOmA/cOiN: A POLITICAL RECALIBRATING PRACTICE</p> <p>90 5.3.1. <i>the aesthetic political: doing politics differently than</i></p>

		<i>politics does</i>	
	92	5.3.2. <i>dynamics of dissensus</i>	
	94	5.3.3. <i>dissensual politics</i>	
		<i>as the building and recalibrating of worlds</i>	
	96	5.3.4. <i>dissensus as a suspending and redistributing activity</i>	
	99	★_6.	
		SHIFTING THE EXPERIMENTING GROUND	
CHAPTER 2	106	★_7.	
		A WALL IN A PRAIRIE SOMEWHERE	
<i>exploring</i>	112	★_8.	
<i>a critical, political, and ethical capacity</i>		THE WALLED HOUSE	
<i>of architectural artifacts</i>	145	★_9.	
<i>in the experimenting ground of</i>		THIS THESIS'S PRAGMATIST APPROACH	
<i>the architecture firm</i>	146	9.1. PRAGMATIST ACCOUNTS OF ARCHITECTURAL ETHICS AND AGENCY	
STUDIOLO	149	9.1.1. <i>(architectural) spatial agency</i>	
<i>architectuur</i>	151	<i>_the role of the architectural artifact in the notion(s) of (architectural) spatial agency_</i>	
	153	<i>_architectural intelligence and situated knowledge; from problem-solving to sense-making_</i>	
	155	9.1.2. <i>congregational agency</i>	
	156	<i>_matter claiming_</i>	
	159	<i>_matter as vibrant_</i>	
	162	<i>_matter that challenges_</i>	
	168	INTERMEZZO: CAN WALLED ARTIFACTS BE POLITICAL?	
	174	9.2. PRAGMATIST ACCOUNTS OF ARCHITECTURE AS AN INTRIGUING TOOL AND INSTRUMENT	
	174	9.2.1. <i>working with resistance, ambiguity, and complexity</i>	
	174	<i>_identifying with resistance, ambiguity, and complexity_</i>	
	178	<i>_on the distinction between walls as boundaries or borders_</i>	
	180	9.2.2. <i>working with probing, provoking, and poetic instruments and tools</i>	
	184	<i>_tools to repair and correct_</i>	
	185	9.2.3. <i>working with constructions</i>	
	185	<i>_the architectonic as a way of loosely constructing_</i>	
	187	<i>_the architectural as a connector in a cosmos of conflicts_</i>	
	194	9.2.4. <i>liberating materiality</i>	
	197	★_10.	
		THE RESEARCH STUDIOLO	
	200	10.1. A JUXTAPOSITION OF FRAGMENTS, CALLING FOR ACTS OF POESIS	
	239	★_11.	
		CHAPTER 2, IN A NUTSHELL	
REFLECTIONS	242	★_12.	
ON CONTRIBUTIONS		REFLECTIONS ON CONTRIBUTIONS	
	262	★_13.	
		REFERENCES	

*INTRODUCTORY
CHAPTER*

★_1.

AN ENTHUSIASM OF ARCHITECTURAL ARTIFACTS MAKING WONDER

My research is rooted in an enthusiasm of architectural practice—an enthusiasm for conceiving, constructing, and deploying architectural artifacts as *poetic instruments* that *act* within their urban surroundings. It explores a poetic agency as a making agency assumed in architectural artifacts and their being deployed. The aim of this thesis, then, is to re-conceptualize the architectural artifact.

Throughout this thesis I will explore and substantiate an understanding of what this *poetic instrumentality* is. I will also expand on the reasons for insisting on the urban as a condition, foregrounding it as the preferred terrain of experimentation. However, first the idea of a research project rooted in an enthusiasm of architectural practice needs further framing.

According to Brad Haseman, a teaching artist and researcher of arts-based learning and creative practice, research problems can generally be made clear either through a research question or through “an enthusiasm of practice” (Haseman 2007). While the former is largely agreed upon as the point of departure for traditional research, the latter is associated by Haseman with practice-led research. Such research is not only carried out through but, as artist and researcher Carole Gray has emphasized, also initiated in practice (Gray 1996, p. 3). The point of departure, according to Haseman, is an encounter in practice with “something that is exciting, something that may be unruly, unmanageable or mysterious [...]” perhaps encountering something “that is just fun to do.” This something makes the researcher-practitioner “‘dive in,’ to commence practicing to see what emerges” (Haseman 2007). Haseman’s idea downplays the monopoly of the research question standing statically at the outset of any research. Instead a more dynamic genesis for initiating and developing research is suggested—one that is situated in an ongoing practice and develops a sense of the problem *within* practice that is addressed *through* practice.

The development of my research corresponds largely to how Haseman describes practice-led research processes. I was already engaged in a set of practices centered on conceiving, constructing, and deploying architectural artifacts in the urban environment when a sense of problem gradually became apparent that called for a slight reorientation of these practices. In the course of this introduction, I will expand on a set of existing practices that form the foundation on which my research developed. I will foreground the sense of problem that emerged within these practices and delineate the aim and scope this thesis had at its outset. Subsequently I will elaborate on how I addressed the problem—through practice—as a fresh enthusiasm of practice. I will present the three experimenting grounds on which this thesis has been structured, and conclude this introduction with a separate section that provides an extensive account of the methodological approach I have used.

However, first I wish to elaborate on Haseman’s “enthusiasm

of practice.” It may give some readers the impression that it establishes a mainly inward orientation, an indulgence in practice as such. However, Haseman associates such enthusiasm directly to “larger agendas or emancipatory aspirations” (Haseman 2007). The connection to larger agendas also orients the inquiry radically outwards, placing at the center not practice itself but rather some shared challenges. Practice here serves as a productive method of addressing these challenges. The presence of emancipatory aspirations in turn further characterizes the contribution of the inquiry in terms of a wider societal impact and relevance. Holding this up as a mirror to architectural practice, the latter undeniably plays out in the web of connections called reality. Herein architectural practice is not to be considered merely a neutral entity that passively awaits connection. Drawing on the work of Albena Yaneva, a sociologist and researcher of architecture, architecture in this web is to be associated with the role of a specific “connector,” both as a practice and an object (Yaneva 2012, p. 108). I have specifically sought to approach the poetic instrumentality of architectural artifacts from the perspective of that non-neutral connecting capacity, which makes matter matter.

For architecture conceived as a way of doing research, the idea of connection / connector can be seen on another level still. Centered on shared matters of concern, the practitioner’s so-called “designerly ways of knowing” (Cross 2006) connect with other ways of knowing, such as those practiced in other disciplines. This also influences how I have conceived the theoretical framework here. In fact, this thesis has no theoretical framework in a traditional scientific sense—one that can be applied and studied in depth, relating it to the issues raised and allowing subsequently for a positioning with regard to that theory. Instead, theories and practices interweave here in a common landscape, providing emerging key positions with specific relevance to the research in the thesis. Thus, I pursue the aforementioned re-conceptualization of the architectural artifact by oscillating between one lens of theoretical concepts and knowledge and another lens of practice-based explorations that develop situated articulations of knowledge. With regard to this interwoven landscape, it should be noted that practice-based designerly ways of knowing are increasingly being deployed within (mixed-method) research efforts. This is because of their perceived ability to contribute to research in ways usually missed by traditional approaches. As Nel Janssens, an architect, spatial planner and researcher in the field of architectural knowledge, has suggested, design is to be considered in this as another kind of knowledge building that can “complement the scientific analysis because design is trained in combining issues of facts with issues of values” (Janssens 2012, p. 81). Design in general, and architectural practice in particular, combines factual reality with how things ought to be. At the same time, it should be recognized that the ways of designerly knowing have limits too. It follows that my research engages various ways of generating knowledge. I will come back to this when expanding on the methodological approach of my research.

Some traits of this methodological approach have already been foreshadowed in characterizing the point of departure for *Architecture’s Poetic Instrumentality* as a particular, reoriented

enthusiasm of practice. The main trait is that of a *research-through-practice* approach that is always embedded in a larger landscape of knowledge, intending to contribute not only to the realm of architecture per se but to agendas that reach out from practice to address larger societal issues and concerns. Knowing there are other frequently used terms, I have opted to use the notion *through-practice*. This is because in my understanding it accords best with the aforementioned idea of the emergence in practice of research problems and challenges and the practices of addressing these—practices such as conceiving, constructing, and deploying architectural artifacts, but also practices of encountering, occupying, and making sense of them in reality, *on the streets*. In my understanding, these latter practices performed by a variety of agents have to be conceived as part and parcel of *research-through-practice*. For similar reasons, I prefer the preposition *through*: more than the preposition *by*, it conveys that wide span where practice is origin, method, development, and result.

Given the emphasis in my research on engaging with a wide span of practices, it follows that its targeted audience is also seen as multiple. In first instance, through the material substantiation of architectural artifacts, it seeks to address those encountering these artifacts. Secondly, my research aims to affect the discipline and practice of architecture. As will be outlined shortly, it intends to answer some urgent calls and challenges specifically raised in aesthetic fields such as architecture. It does so in a variety of ways: by demonstrating and raising an awareness of certain underexposed capacities of the architectural artifact; by proposing according design attitudes; by using experiment to develop *different* modes of practicing and educating in architecture; and by broadening the usual conceptualizations of architectural artifacts and according aesthetics. With these explorations and propositions I aspire to make a meaningful contribution to the existing registers of architectural knowledge.

I want to shortly note that in this thesis no clear distinction is made among the notions of object, thing, artifact, body, and so on. When talking about architecture, I have often opted for the term *artifact*. Although I am aware of the differences among these notions, the discussion of those differences is beyond the scope of my research. Also, I have opted to avoid as much as possible the usage of a generalizing *we*. If I make mention of a *we*, it is in reference to the group of people I was collaborating with at that time (students, teaching colleagues, research colleagues, our architecture firm, etc.).

___ 1.1. BACKGROUND OF THE RESEARCHER: A SET OF ARCHITECTURAL PRACTICES

*** *_a practice of encountering architectural artifacts***

I have always been fascinated by architectural artifacts that were conceived, constructed, and deployed in the urban environment not merely as material forms but as connecting entities. As a wanderer and urban inhabitant, I consider a lifetime

of encounters with such artifacts to be a substantial practice itself. One night in a city, I came upon a man who was taking shelter from the wind in a glass and steel cubicle mounted on a stone base, where he was warming himself at a bonfire amidst the bags that held his belongings. Between the assemblage of materials and the man inhabiting it, an unforeseen act of *making* unfolded. Later I found a picture in a journal reporting on that socio-spatial event (Fig. 0.1). In my reading, the event testifies to an intriguing moment of connection between different ideas on how to conceive of urban public space. In the picture, a man in a fluorescent vest hesitates to enforce what he knows to be the proper way of utilizing or inhabiting public space. The warmth also starts to affect his skin, pouring in. Having witnessed this scene myself, I cannot but wonder, ponder, and weigh. I am prompted to make sense not only of the specific scene encountered but also of the wider socio-spatial ramifications. How can one conceive of the urban environment as a *common space*—a shared commons agreed upon as a principle, but with the interpretation of that principle left as multiple and a matter of intense negotiation? In this instance of *making*, which implies the making of sense and with it the negotiation of values, the architectural artifact—and its deployment—has been a complicit agent. Radiating its affordances with some degree of ambiguity, it has allowed for deviant readings. It has, whether by chance or deliberately, invited negotiations to take the stage it has provided.

A lifetime of such encounters with architectural artifacts is not the privilege of the professional practitioner. It pertains to each and every person wandering the urban environment. I consider this practice of encountering and experiencing architectural artifacts on a non-professional level to be an important trace within the set of practices underlying the research in this thesis. This consideration has led me to substantiate architectural artifacts in urban environments as an essential part of the research—in various collaborations and spread over three different experimenting grounds. It follows that one of the important aims has been to contribute to and as such expand the registers of encounters affecting those wandering the city. These registers must be considered records of situated knowledge.

Besides a practice that comes as a personal history of encounters, I have been engaged in architecture in a variety of professional practices—practices I see as inextricably interwoven. In order to briefly outline them, I will consider them separately. Three professional practices can be discerned: a practice of teaching architectural design; a practice of collaborating in an architecture firm; and a practice of crafting architectural artifacts. In outlining each of these practices, I will point out the common problem emerging in them.

* *a practice of teaching architectural design*

Since 2006 I have been working at the Sint-Lucas School of Architecture in Ghent and Brussels, now the KU Leuven Faculty of Architecture, Campus Sint-Lucas. Specifically, I have been active in teaching, developing, and managing of the Master of



Figure 0.1: a man making a home in the city. Photograph retrieved from <https://m.bln.be/nieuws/binnenland/mag-bet-wat-warmer-dakloze-stoekt-vuurtje-in-historisch-centrum-gent~a64d9fbf>.

Interior Architecture program from its inception in 2003 as a freestanding degree program within the school. I will refer to it regularly in this thesis. In parallel with that program, also Master of Architecture, Master of Urbanism, and Bachelor of Interior Design programs are offered. The Master of Interior Architecture is similar in many ways to the Master of Architecture. It is fundamentally an architectural program, and the two have many courses in common. However, there is a radical difference in their perspectives on architectural design and their approaches to reality. The main difference, aside from the level of detail in their focus, is that the Master of Interior Architecture works from a fundamentally *embodied* perspective, *from within* things, situations, realities. The program therefore nowadays gives a great deal of attention to the students' engagement and agency. I would argue that my research exemplifies that perspective. Sometimes in this thesis the notions of architecture and interior architecture may seem conflated. The above short description may help to explain and address that conflation.

A persistent concern I have worked on in the Master of Interior Architecture (MIA) program has been to forge more explicit connections between the teaching of architectural design and the fertile, complex, and also compromising substrate called reality. It is problematic that architectural design is too often initiated and taught in laboratory conditions, so to speak, based on the sterility of abstract and imposed briefs that are left unproblematized. With regard to their artifacts, students are trained in aspects such as aesthetic appearance, rational functioning, and conceptual coherence. Often what is lacking is a rendering explicit of the agentic capacities of both artifact and practitioner, and also an awareness of the designing activity performed by those encountering and occupying designed artifacts. Also frequently overlooked is the multitude of connections that are made as these artifacts emerge. Adding to this deficit, which arguably affects architectural design education in general, the role associated with the interior architect is recurrently conceived as a servile service provider—someone who arrives at the scene after all the interesting dust resulting from all kinds of connections and frictions has already settled. In the development of the MIA program, the aspiration has been to forge a different conception of the role of the designer and the design. There have been efforts to re-conceptualize architectural artifacts somewhat and change the attitudes bringing them into being. In these efforts, a productive connection between the interior and the urban context has been one of the premises.

From among my own efforts to address the above problem, I have chosen to feature in this thesis my work with the (research-through-design) MIA studio Complicating Machines / Complicating Interiors (CoMa/CoIn). I started the studio at the outset of my research in 2010, and it still runs to this day. The CoMa/CoIn studio establishes one of the three experimenting grounds that support and structure this thesis. Some CoMa/CoIn artifacts will take the lead in Chapter 1, titled “Exploring a Critical, Political, and Ethical Capacity of Architectural Artifacts in the Experimenting Ground of the CoMa/CoIn Design Studio.” As the title suggests, what will be explored here through

conceiving, designing and deploying architectural artifacts is architecture's critical, political, and ethical capacity. Along the way, other thoughts, practices, and artifacts are interwoven, constituting the landscape of discovery of this thesis. The main contribution of Chapter 1 is that it gives substance to how ideas and mechanisms such as “dissensus” (Rancière 2010; 2011) and “agonism” (Mouffe 2010; 2012; 2013), while formulated in political philosophy, may be deployed architecturally. Large parts of the research will revolve around the idea of architectural artifacts conceived, constructed, and deployed as *agonistic stages*, a notion I will come back to. Once more I think here in terms of a specific contribution to agendas that extend beyond practice to touch on larger societal issues. Here that larger agenda is formulated within political philosophy, though accompanied by an explicit call upon aesthetic practices such as architecture.

Counteracting the emerging problematization of architecture and architectural education suggested above—a problem of agency—the CoMa/CoIn studio situates the designing activity of its students radically within the urban context, working at the socio-spatial scale of 1:1. There it conceives, constructs, and deploys so-called “complicating machines” (Rajchman 2000, p. 51), or interiors that raise new questions rather than merely solving initial questions in servitude. In that sense, they contribute to a substantiation of the poetic instrumentality of architectural artifacts I am exploring.

* *a practice of collaborating in an architecture firm*

In addition to teaching, my set of architectural practices includes collaborating as a partner in the architecture firm STUDIOLOarchitectuur to varying extent since 2010. Here, as in my teaching practice, the urban environment constitutes the space of daily operations in which we intervene mainly on the scale of the (row)house and its interior. Like the architecture school, our office has seen an intensifying interest and challenge in approaching architectural artifacts *differently*—that is, to conceive, construct, and deploy them more radically from the perspective of their specificity being inscribed in urban socio-spatial surroundings. This intensifying interest has led us to participate in some specific architectural competitions that aim not merely to develop architectural artifacts but to produce *change* within the urban environment—through small-scale architectural interventions on the scale of the (row)house and its interior. We took seriously this aspiration for urban transformation by means of architecture, which clearly surmounts concerns of taste, functionality, or conceptual coherence. Again, what is explored is architecture's poetic instrumentality, traced though in a second experimenting ground: that of an architecture firm operating in an urban context.

Exemplifying the enthusiasm of architectural practice in this experimenting ground is the firm's Walled House project. It came into being as the result of a proposal for a competition organized by Stedelijk Ontwikkelingsbedrijf Gent (the Urban Development Company of Ghent). I deliberately use the term

Figure 0.2: *Complicating Machine / Complicating Interior CoMa₀₁*. Photographic collage: Joban Liekens.



Figure 0.3: STUDIOLOarchitectuur's *Walled House* project. Photograph: Stijn Bollaert.

result because there is a fundamental difference between how the Walled House was designed and how it became deployed in reality. That difference all too easily could be read as a partial failure of the project's intended agency. However, I will argue that what is at stake here is a fundamental difference between architectural interventions that work in the urban environment in political ways and those that work conversely in policing ways. The Walled House artifact, how it was designed and executed differently, sets out and propels Chapter 2, "Exploring a Critical, Political, and Ethical Capacity of Architectural Artifacts in the Experimenting Ground of the Architecture Firm STUDIOLOarchitectuur." Chapter 2 also further elaborates on philosopher Jacques Rancière's distinction between "political" and "policing" activities, formulated in the realm of political philosophy (Rancière 2011; 2010, p. 37). As in Chapter 1, a variety of thoughts, practices, and artifacts are connected to the project, thus expanding the landscape of discovery. The main contribution of this Chapter 2 can be situated in the idea it develops and substantiates of architecture as a pragmatist instrument, which as such deploys architecture's political and ethical capacities and agencies. Again the emphasis is on a contribution through practice to larger agendas, one that is substantiated through the specificity of professional architectural practice. There is no strict boundary between the first and second chapters. Instead, there is a shifting of the experimenting grounds between the two, and with that a further development of an understanding of what this probing, provoking, and poetic instrumentality of architectural artifacts might be.

It is worth noting that when thinking of a name for our office we opted to refer to Antonello da Messina's painting *St. Jerome in His Study*. In the painting there is a somewhat artificial inscription of an interior architectural artifact in what could be seen as a public urban setting. After having named our office I stumbled upon author Georges Perec's interpretation of the painting, in which he holds that it is the capacity of that artifact—the *studiolo*—to make inhabitable the empty and glacial space in which it is inscribed, thus giving it sense (Perec 1974, pp. 117–18). Throughout this thesis I will connect the idea of displacing and inscribing architectural artifacts to the mediation of the inhabitability of the urban environment.

* *_a practice of crafting architectural artifacts*

In my professional architectural practice, I have recurrently engaged in different ways with the aspect of craft in architecture. One of these has been the exploring and diagnosing of architectural heritage. In this practice I have developed a fascination for the material exploration of architectural artifacts. Figure 0.4 shows me practicing such an exploration, hanging from ropes to survey in detail a medieval donjon. This engagement has given me the opportunity to encounter architectural artifacts in ways not many people do. I have tasted, so to speak, these artifacts' materiality and articulations and the ingenious craftsmanship with which they became substantiated. Through this kind of practice,



Figure 0.4: *exploring a donjon hanging from ropes. Photograph: Andries Deknopper.*

architecture became an ultimately embodying experience for me, and this has surely influenced the affinity for architectural artifacts that characterizes *Architecture's Poetic Instrumentality*.

I have recurrently teamed up with people who are skilled in the making aspect of architecture, collaborating not merely in the analysis but in the crafting of architectural artifacts. I specifically think here of the intense periods of collaborating in *Compagnons*, a collective of carpenters who build wooden structures of all kinds and scales using solid wood as their main raw material. Besides conferring a physical acquaintance with the aspect of crafting architecture, these experiences helped me forge a profound relationship with the palette of sensations that matter provides. No scent as intense as the fresh shavings of oak, beech, and pine. No act as satisfying as calibrating and tacitly positioning the final wooden peg that tightens the wood frame. In my professional life as an architect, I have deliberately provided space for such explorations of making architecture, strengthening one aspect of what I consider to be *craft* in architecture.

Fueled by this fascination for crafting architectural artifacts, during the course of my research I have set up the project called *Research Studiolo*. This project is discussed in Chapter 2 in its current unfinished state—a temporal stability that is already in flight again. The *Research Studiolo* constitutes a laboratory or base camp for further exploration of the previously mentioned architectural practices (practice of encountering, practice of teaching, practice of the architectural office, practice of crafting). I conceive of this project as a third ground for experimentation, this one centered more specifically on the crafting and constructing of architectural artifacts. This third experimenting ground can be situated close to the second, and linkages with the first have occurred. Its specificity is that the usual division of labor separating the genres of architectural creation, such as designing, constructing, and occupying architecture, is suspended. A poetic instrument is conceived but (quasi-simultaneously) also physically and materially constructed and deployed in the urban environment by the same heads and hands. Similarly, there is no linear process of emergence. Instead, the artifact emerges from all the connections it makes. In both senses, a form of slow architecture is constituted. At the center of the adventure is again



Figure 0.5: Seppe Geuens of *Compagnons* preparing the wooden center pillar of a medieval gateway. Photograph: *Compagnons*.

Figure 0.6: Making joints at *Compagnons*. Photograph: *Compagnons*.



Figure 0.7: Willem De Loore calibrating wooden pegs at *Compagnons* on an instrument tool that also stimulates conversation. Photograph: *Compagnons*.

Figure 0.8: Constructing architectural artifacts with *Compagnons*'s Seppe Geuens and Dries de Loore. Photograph: *Compagnons*.





Figure 0.9: *The Research Studiolo project.*
 Photograph: Johan Liekens.

the aspiration to substantiate an architectural artifact as a *poetic instrument* and *agonistic stage*.

* *_practices in different experimenting grounds?*

As suggested, the practices underlying the research in this thesis are inextricably interwoven. That said, they are characterized by different sets of possibilities. In an educational practice the possibilities are few, or at least differently restricted, and expressions can be loud, so to speak; an architectural practice, on the other hand, is heavily constrained in every sense. There are countless sets of regulations, which cannot be ignored. This certainly is the case for an architectural practice operating in an urban setting, colliding with a multitude of interests. There is also the reality of often harsh financial constraints and the overwhelming weight of the official brief that at times seems to be written in stone. However forceful these constraints may be, they are to be considered interesting challenges, too. What has intrigued me in experimenting on a poetic instrumentality within the constraints of an architectural practice has been how to prepare and arrange architectural artifacts so that a poetic production could unfold. This I have pursued by infecting architecture's usual flesh with provocative articulations that could ignite such a production. The intended agency is similar to what architect Wim Cuyvers has described in his work as "intentional additions" or "corrections" to the official briefs of his commissions (Cuyvers 1995, p. 40). These corrections trick and escape the forces supervising the fit between intended and actual functioning. They initially pass by unnoticed, only taking on their wonder-full agency with time.

With regard to the different experimenting grounds, early in my research I proposed a gradient spectrum foregrounding the architectural artifact as either inviting, provoking, or shocking one to think. While an educational practice can perfectly develop its artifacts in the latter half of the spectrum, I believe a professional design practice (unlike the arts, for example) has the most potential within the first half, working through subtle articulations or better alterations (Fig. 1.10).

One last distinction among experimenting grounds I want to add is an aspect that relates to time. Architecture in professional practice comes into being only slowly, taking years from the initial design through the different stages of construction, remaining in process until finally occupied and subsumed into the urban context. The slower that process, the more connections the architectural artifact is able to make. Logically this aspect influences the experimentation. In the third experimenting ground of crafting and constructing an architectural artifact as a poetic instrument and an agonistic stage, the idea of slowly and painstakingly following architecture will have its expression.

As suggested, the three different experimenting grounds (educational practice, professional practice, practice of crafting architectural artifacts) have helped structure this thesis. In the first experimenting ground, I explore in the thesis architecture's critical and political capacities through the educational practice and artifacts of CoMa/CoIn. This constitutes the subject

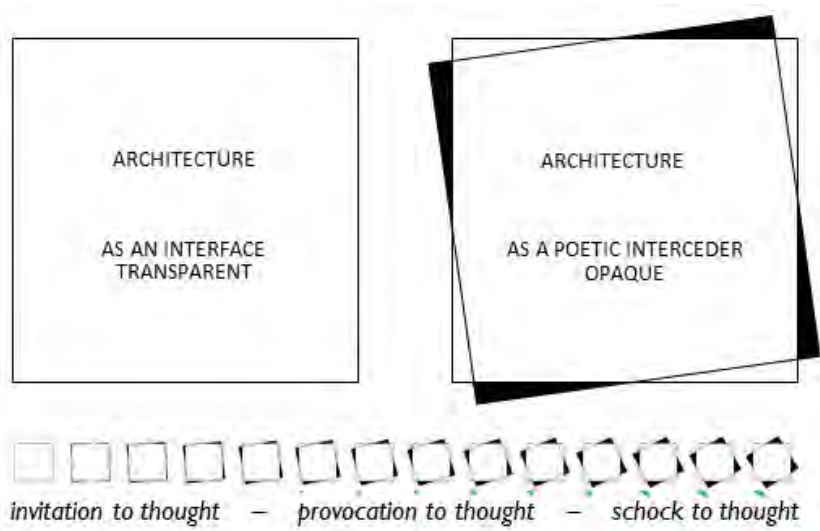

Figure 0.10: Gradient of estrangement, from invitation to provocation to schock to thought. Scheme: Johan Liekens.

matter of Chapter 1. In the second and third experimenting grounds, I explore aspects of architecture's political and ethical capacities related to design projects in my work with STUDIOLOarchitectuur. This constitutes the subject matter of Chapter 2.

* *_all practices in the urban environmen*

In the above I have laid out the set of practices in which and through which my research emerged. One aspect that characterizes all of them is their engagement with the urban environment. I have from the outset paired an interest in architecture's critical, political, and ethical capacities with a passion for the socio-spatial phenomenon that is the city. As suggested before, my CoMa/CoIn class experiments with an inscription of the interior in direct connection and confrontation with the urban fabric, aiming to develop a certain socio-spatial production. In the work of STUDIOLOarchitectuur, the urban environment is the stage of daily operations too, aiming increasingly for a similar poetic production that can transform the urban at local points. The Walled House project evolved from participation in a consciously chosen competition intended to bring about such transformation through acupuncture-like architectural interventions.

Characterizing this commitment to the urban environment, I think of scale and conceptualization, two aspects I see as interconnected. With regard to scale, I subscribe to the potential in local, site-specific, and small-scale experimentations and to corresponding strategies of addressing the urban environment. Here everyday phenomena and practices are considered key. The architectural artifacts embedded here all testify to this in their substantiation of local testing grounds aimed at a local, site-specific, and small-scale socio-spatial transformation of the urban environment. In the case of the Walled House project in particular, and in the competitions set up by SOG, the urban development visioning organization for the City of Ghent. In general, such transformation is seen as an incubating seed with the potential to spawn wider urban change.

Besides its reference to a particular scale and focus on working in architecture, I align with sociologist Saskia Sassen's understanding of the urban environment as the ultimate locus of the political (Sassen 2006, p. 3). Taking into account the aforementioned capacity to negotiate change or transformation, Sassen's characterization of the urban environment here serves as a mirror, identifying it as the ideal ground for experimentation. The urban environment itself can indeed be considered an inherently political space—a space that is both common and divided, and as Rancière has suggested, “there is politics because the common is divided” (Rancière 2011, p. 1). Of all categories of space, according to Sassen, urban space is the most “concrete” space of the political in the sense that in the urban environment the many non-formal and therefore often invisible political actors can also express themselves politically through their practices (Sassen 2006, p. 3). There is no “pure politics,” no “disposition” or “destination” to politics, “no political life but a political stage” (Rancière 2011, pp. 3–4). As Sassen emphasizes, “much of urban politics is concrete, enacted by people” (Sassen 2006, p. 3). According to her, it follows that in the urban environment there is a kind of “public-making” that also produces “disruptive narratives,” which “make legible the local and the silenced” (Sassen 2006, p. 7). I refer here to the aforementioned encounter with the socio-spatial assemblage of a man making home in the city (Fig 0.1). I thus conceive of the urban as *thick*, multiple, and *assembled* in nature. As a consequence, it is conceived as always in-the-making, continually re-calibrating itself.

One implication of the above is that whenever I refer to the urban environment, I deliberately make no distinction between different kinds and scales of urbanity (e.g. the specificity of the Belgian case versus other kinds and scales of urbanity, or the distinction between metropolitan urbanity and suburban urbanity). Instead I always mean to hint at this concentrated force field of everyday practices that connect and negotiate as acts of “urban poesis” (Sassen 2006, p. 1). In this force field, architecture is explored as a poetic instrument that is able to critically reveal, politically negotiate, and ethically interrogate, and thus to re-partition reality. It follows that any reference to the notion of the political or politics in this thesis is tied to this understanding of the urban environment.

1.2. PROBLEM AND CHALLENGE

As suggested, the propelling enthusiasm of architectural practice revolves around a re-conceptualization of architectural artifacts, insisting on what I call their poetic instrumentality. While this is the research subject to be explored throughout practices and practicing, some seminal ideas on what could constitute this poetic instrumentality were present at the outset of my research. I present these ideas below, and in so doing the problem I wish to address through my research becomes more clearly delineated.

In this thesis I speak of architectural artifacts rather than of architecture. In my understanding, the notion of *artifact* fittingly

suggests a relationship to the making (from the Latin *facere*) aspect characterizing artifacts, a sense of being made and being in the making. Also I associate that notion with a somewhat disturbing, artificial presence (of the artifact) and as such with the deliberate creation of an experimental situation. Speaking in terms of architectural artifacts in itself introduces an aspect of the poetic instrument, which through an artificial, altering presence instigates a certain making by those who encounter it.

In outlining the research topic I have followed a fascination with architect Aldo Rossi's observations on architectural artifacts, related in his book *A Scientific Autobiography*. Herein a similar evolving conceptualization can be found in which the architect increasingly starts to conceive of his architectural artifact as an apparatus (Rossi's "apparecchio")—an "instrument which permits the unfolding of a thing," an instrument that is not just an artifact as such but also a "vehicle for events." Rossi identifies architecture as a practice of "preparing" instruments, of "arranging" and "setting" them (Rossi's "apparecchiare") (Rossi 1984, pp. 3–5). Such a preparing activity contracts the intention of the architect with the contingent life of architectural artifacts. This implies a contraction between the realm in which architectural artifacts are conceived and that in which they are received—used, appropriated, occupied, and contested.

When Rossi lingers on the effect of a strange photograph in his possession, a photograph of a young man's face behind the grate of a monastery, he identifies that grate as the material artifact that arranges the occurrence of that specific event. The process here clearly bears similarities with the aforementioned man making a home in the city (Fig. 0.1). While such socio-spatial events essentially just happen, it seems worthwhile to explore architectural artifacts more consciously based on their potential to *make them happen*, an effort around which the research in this thesis is organized. As is suggested in Rossi's image, in this exploration the role of architectural matter is not to be underestimated. This is one of the reasons why I have relied so much on materializing architectural artifacts and on thereby realizing poetic encounters.

When speaking of the preparing and arranging of architectural artifacts awaiting the arrival of that suspenseful moment (that moment of both suspense and suspension) in which things unfold, the image of architecture as a stage and a way of staging comes to mind. It should be noted that the notion of the stage is one that also regularly surfaces in Rossi's writing and work. Rossi claims that such a stage, "like every good project, [...] is concerned only with being a tool, an instrument [...] where a(n) [...] action can occur." On such a stage, "the experience of every combination" is tested; it is "the artisan's or scientist's work-table," fundamentally "experimental" while "casting its peculiar spell on every experiment" (Rossi 1984, p. 33).

It may seem contradictory that while being intrigued by and drawn to the contingent life of his architectural artifacts, to their own peculiar productions, Rossi often uses terms such as apparatus, instrument, mechanism, and operation. All of these are associated with mastery and precision rather than with the contingency of artifacts implicated in productions and makings

themselves. I have always been intrigued by this paradox, to the point that I have integrated it into the title of this thesis. More precisely, I have contracted in it the notions of *poesis* and instrumentality. It is clear that the term *poetic* used throughout this thesis is one etymologically rooted in the ancient Greek word *poiesis*. The latter describes a *making* as well as a *making up*—a making in the mind. Of course, an architectural artifact is not merely the servile instrument compliant with intent, developing through a controlled sequence of necessary operations in order to reach a pre-established goal. As I've already noted, my research subscribes to far more challenging conceptualizations of the architectural artifact. That said, an instrumental terminology in my understanding realizes exactly this: it modestly backgrounds aspects such as aesthetic appearance, logical functionality, and conceptual coherence in order to foreground a specific kind of performativity—one that resides within artifacts themselves and / or in the deployments of and dealings with them. Central is what an artifact can *do*—that is, how it can develop in reality and how it can alter that reality, in addition to these other aspects pertaining to the usual scope of architectural creation (aesthetics, functionality, the architect's emblematic concept). The kind of instrumentality I propose is thus a radically poetic one. More than providing answers or material artifacts as such, it sets the stage and constraints for its own peculiar, partially independent, and therefore wonder-full production. As a result, in Rossi's words, "the architect must prepare his instruments with the modesty of a technician; they are the instruments of an action which he can only glimpse, or imagine, although he knows that the instrument itself can evoke and suggest the action" (Rossi 1984, p. 20).

As a poetic instrument, the architectural artifact is thus reconceived as an experimental stage on which things are never just given but instead fundamentally *made*, negotiated and *poeticized*, so to speak. In this sense, the artifact not only becomes a vehicle for events but also an instrument of inquiry. It probes reality by projecting its own particular socio-spatial productions. Material making becomes bound with this *other sense* of making. Matter is made to matter. With this comes a bifurcation of making agents. I refer here to the agency of artifacts and the making activities of those encountering and interacting with them.

In Rossi's insistence on the role of the architect as the setting, preparing, and arranging of artifacts, the idea of mastering architecture shifts. It gets replaced by a more modest idea of craft conceived as an experimental making activity. A consequence of conceiving architecture more modestly is paradoxically to heighten the potential of architecture. Because of the relevance of the events unfolding, architecture assists in the production of reality. The idea of preparing artifacts itself also downplays the need for architecture to always offer something new and unique. At work here is a tentative re-composing through slight alterations. Similarly, I do not aspire to bring something completely new into being. Instead, my intention is to recompose what already exists and base my work on its capable and established foundation. The main aim is to raise an awareness of and a sensibility for some of architecture's neglected potential, thus contributing to its resuscitation.

The idea of resuscitating some capacities of the architectural artifact pins down what is considered to be at stake. In addressing the urgency of such resuscitation I am not alone, joining a variety of voices that have called upon architecture to become more active again in fundamentally shaping reality. Among them is architectural theorist Sanford Kwinter, who, engaged in an effort to re-conceptualize architecture and its artifacts, has characterized architecture's capacities of acting in the world—practically, ethically, and politically—as currently “atrophied” (Kwinter 2002, p. 5). Considering the multitude of interactions one has with artifacts every day, and aligning with Rick Robinson that these “have enormous impact on how we think” and shape reality (Robinson 1994, pp. 77–79), it follows that such resuscitation is vital. Closely related to the image of the atrophied architectural artifact, architectural theorist Roemer van Toorn claims that architecture is currently at risk of becoming “a-political” (Van Toorn 2006, p. 57). With these estimations in mind, I reconnect to the aforementioned idea of the urban environment as the most *concrete* space of politics. Thus, to deploy the architectural artifact as a poetic instrument in the urban environment is to make it a critical, political, and ethical instrument that influences the everyday behaviors practiced there and the worldviews produced there. Kwinter and Van Toorn's estimations can be read against the background of the contemporary discussion on the critical and post-critical in architecture. Aspects of this discussion will be used as underpinnings to explore the critical and political capacity of architecture in Chapter 1.

While the voices referenced above come from within architecture, my research also notes calls from outside the field. I perceive these as wake-up calls prompted by the urgency of certain matters of shared concern. They set the larger agenda(s) to which my research intends to contribute. Herein architecture is challenged to think of its wider relevance. There is one call in particular I have wanted to answer. While raised by political philosopher Chantal Mouffe from within her discipline, it is a call that specifically challenges aesthetic practices such as architecture to reinvent themselves as “agonistic practices.” As such, they join the common challenge of producing “agonistic public space” (Mouffe 2010; 2012; 2013). Within the framework of Mouffe's own field, *agonism* is considered a political concept and practice that must be exercised in order for democracy to be preserved. As I have noted previously, I hold that architecture (and its artifacts) can be such a political practice too, playing what Mouffe considers an incredibly important role in the production of new realities (Mouffe 2010, p. 119). Architecture does indeed have unique capacities for making sensible, to make sense of reality. It is able in a unique way to mingle issues of facts with issues of values. According to Rancière, what aesthetic practices are able to do is “re-partition the sensible” (Rancière 2010, p. 37). Thus, aesthetic practices are able to “produce a new perception of the world, and therefore [...] create a commitment to its transformation.” Rancière foregrounds three coinciding processes in this production: “the production of a strangeness,” “the development of an awareness of the reason of that strangeness,” and “a mobilization of individuals as a result of that awareness” (Rancière

2010, p. 142). While the production of a strangeness can easily be related to the artificial and somewhat disturbing presence of artifacts suggested before, the latter two processes accord well with an instigation of thought and action through that presence. Condensing the above, the artifacts developed within the span of my research are conceived, constructed, and deployed as agonistic stages on which thought is provoked and action triggered. On these stages, “the idea that we have of the world, of who we are, of what our shared values are” is continually construed and kept in construction (Mouffe 2012) and on them the sensible is made subject to constant re-partitioning.

I have been fascinated from the outset by a suggestion encountered in philosopher Gilles Deleuze’s *Difference and Repetition*. He prompts to “count upon the contingency of an encounter with that which forces thought to raise up [...]”. Something in the world forces one to think. This something is an object not of recognition but of a fundamental encounter” (Deleuze 1994, p. 139). Deleuze’s words here evoke some of the traits of the poetic instrument as it was roughly sketched out above. It alludes to a practice of contingently encountering and, moving one step further, to a practice of bringing about or staging encounters that provoke thought to unfold. While Rossi speaks of *events* unfolding on architectural stages, Deleuze here suggests that what could unfold is thought. Thought thus unfolds within the world, resulting from everyday encounters. It is not found in territories severed from reality—in abstract and distant heavens. I have always conceived of the relationship between architecture and thinking in these terms. Adding to this, the insistence on the logics of encounter and not of recognition, to use the Deleuzian distinction, lays wide open the possibility of conceiving reality anew, transforming it at local points.

One other initial interest present at the outset of my research has been that in the realm of critical design as proposed by Anthony Dunne and Fiona Raby, both designers as well as researchers in the field of design and social inquiry. The concept relates to the idea of architectural artifacts provoking thought and action, specifically with their concept of “para-functionality,” a “functional estrangement” designed *into* artifacts so that “function is used to encourage reflection.” While still “within the realms of utility,” Dunne states, the aspiration is “to go beyond conventional definitions of functionalism to include the poetic” (Dunne 1999, p. 44). Here another effort is found to re-conceptualize the artifact, again involving the notion of the poetic. In this effort, the critical in critical design is associated with the capacity to raise critical reflection.

To Dunne and Raby’s criticality I want to bring an observation made by Catharina Dyrssen, an architect and researcher of design methodology, on the specificity of design and designed artifacts. This specificity is that design, as a practice but importantly also as a research discipline, has an inherent double capacity to combine the critical with the suggestive (Dyrssen 2011, p. 233). Criticality is understood as not just the analysis of a situation. Simultaneously or, using Dyrssen’s stipulation, in a back-and-forth movement with quick shifts from one to the other, the critical interchanges with the suggestive (Dyrssen 2011, p. 226).

Thinking critically here is bound to the making of (critical) projections through projects. This making of projections is associated by many with a political capacity of artifacts. I return to this periodically throughout my research.

It is to be noted that Dyrssen's observation correlates both to the macro level of my research (i.e. its methodological approach) and to the micro level of its composing artifacts. She states that "the actual 'doing' [...] becomes a way of examining the 'problem' at the same time as that which is being created [...] becomes more and more informed" (Dyrssen, 2011, p. 226).

In the preceding parts of this introduction I have delineated an enthusiasm of architectural practice with which *Architecture's Poetic Instrumentality* was begun and through which it has been explored. I have indicated that such exploration would revolve around a poetic instrumentality assumed in architectural artifacts—that it would target the critical, political, and ethical capacities of artifacts deployed in the urban environment. I have situated this enthusiasm and the problem and challenge emerging with it within larger and shared agendas, thereby expanding the scope and raising the stakes. I have focused on different experimenting grounds, which has led to the development of the different chapters of the thesis, addressing different audiences. I have also hinted at the main methodological approach. The following part of this introduction is allocated mainly to this research-through-practice approach.

It should be noted that, while I have aligned above with Haseman to foreground an enthusiasm of practice to make clear the research problem, I have also formulated an initial research question in parallel:

Q1: In what ways could architecture go beyond a narrow definition of its instrumentality and be seen more as a challenging instrument for provoking thought and action in those encountering architecture and less as a functional solution, an aesthetic appearance, or a closed concept?

Some sub-questions derived from this:

Q1.1: What is this thought and action that the architectural instrument is able to instigate and unfold beyond?

Q1.2: How can one extend the notions of function and aesthetics in architecture to also include a more poetic working of architecture within reality, touching profoundly architecture's users or those encountering architecture?

Q1.3: Why would the architectural instrument be the proper instrument, even a condition for provoking and poeticizing in these ways?

Q1.4: What impact could the conscious application of this extended instrumentality of architectural artifacts have on architectural practice, discipline, and education, and beyond that on socio-spatial reality itself?

Q1.5: To what extent is the notion of conflict important for this extended instrumentality?

METHODOLOGICAL POSITIONING

___2.1. A RESEARCH-THROUGH-PRACTICE APPROACH: MAKING ARCHITECTURE AS A METHOD

The main methodological trait of my research is a *research-through-practice* approach. As noted previously, I have specifically opted to use this term, well aware that this approach goes by many names. In this section, I wish to expand on how I understand this approach. I begin by inserting an intriguing observation by John Law, a researcher in the field of sociology and science and technology studies, that methods are not solely methods but in fact reflect one's being and aspirations. They point to how the world is seen or how one hopes to make the world (Law 2004, p. 10). Law's observation is reflected in how I have assembled my methodological approach. Because I am passionate about architectural practice and convinced of its capacities for acting upon reality, practicing needed to be substantially present and central as a method for generating knowledge. This is also reflected in the exploration of developing architectural artifacts as poetic instruments, in this thesis as well as in the urban context in which they are now deployed. These artifacts pique the minds and bodies of their users, whether they are reading this thesis or strolling through the urban reality, and aspire to reframe how a (local) world is seen and understood.

If the intention is indeed to act upon reality, to reveal aspects of how it is and how it is made, then it is necessary to consider which matters of concern are more broadly shared with other disciplines and how these become addressed methodologically in these. A perspective operating *from within* (through-practice) thus goes hand-in-hand with ways of knowing or gaining knowledge stemming from outside of architectural practice and discipline. This implies that architectural design research prospers from cross-fertilizing its own specific approaches with relevant approaches from other disciplines.

First, I will lay out research-through-practice as a methodological approach that essentially operates *from within* architectural practice. I will focus on architecture as a method without losing sight of the necessity of embedding it in wider knowledge landscapes. I will discuss this against the background of the particular research milieu in which my research has emerged, and in which various people and ideas have been important. Second, I will position my research as it relates to some of the established ways of diagramming design research. I have specifically selected these diagrams because of resonances with how I conceive of my research in terms of content and methodological approach.

In the next paragraphs, aligned to the right in the text, I will identify some of the characteristics of the research-through-practice approach deployed. I will number them and continue the numbering when diagramming the design research. This numbered list can be read as a summary.

**research-through-practice:
(1) an explorative methodological approach
operating from within practice;**

The milieu in which *Architecture's Poetic Instrumentality* initially emerged at Sint-Lucas School of Architecture has played a crucial role in the development of my methodological approach. I was trained there as an architect from 1991 till 1996, and since 2006 I have been intensely engaged in teaching, managing, and research. I understand this milieu as promoting an explorative attitude, not at least in its students. I relate this attitude to researcher of design Nigel Cross's idea of approaching problems "as a [...] partial map of unknown territory" in which the designer discovers through design "something new, rather than to return with yet another example of the already familiar" (Cross 1999, p. 28). Problems are not merely given and solved. Instead, design projects fundamentally serve to set problems.

While an explorative attitude is indeed the aim, Sint-Lucas has also traditionally grounded its teaching firmly in architectural practice. This is mirrored in the mixed activity of its teachers. The base philosophy is that practice operates as a perspective *from within* that is deemed indispensable for future practitioners. This combination of an explorative attitude and a simultaneous grounding in practice is a core element of the approach assumed within this thesis.

In the aftermath of the 2003 Bologna-Berlin reformation, which recognized doctoral studies as the third cycle of European higher education, the research culture at Sint-Lucas School of Architecture rapidly became more explicit. According to pedigree, exploration through design and a firm grounding in practice were made defining characteristics. The staff was challenged to develop concepts of what was referred to as research-by-design. The aim was to not merely mirror established, discipline-based ways of conducting research (Verbeke 2006, p. 9). As pointed out by Halina Dunin-Woyseth and Fredrik Nilsson, both architects and researchers in the field of design research, it led to the Sint-Lucas research milieu in Belgium now constituting "the main locus for research by design and [...] consequently worked in order to establish this mode as the institution's research strategy" (Dunin-Woyseth & Nilsson 2012, p. 47).

Embedded as I was in the culture of Sint-Lucas, I quite naturally approached my research *by-design*, though I used slightly different terminology (*through-practice*). Being a domain in development, research-by-design not only goes by many names but also has many interpretations, some of them fundamentally different. What is shared, however, is the acknowledgment of the disciplinary specificity of design itself as a practice and mode of (practice-based) research (Rendell 2004; Cross 2006). Practice herein is conceived as a "methodological vehicle," as stated by researcher in the field of theory of research Henk Borgdorff (Borgdorff 2010, p. 46). It is an instrument for "research in which the professional and / or creative practices of art, design and architecture play an instrumental part in an inquiry" (Rust et al. 2007, p. 11). What sets the different interpretations apart

fundamentally is whether practice and design lead, ground, or base the research, or whether they altogether equal research. Linda Groat and David Wang, both researchers of design research, have stated that practice and design on one side and research on the other “embody many important similarities, including many complementary and overlapping qualities.” However, they constitute “relatively distinct kinds of activity,” each with unique qualities (Groat & Wang 2013, p. 23). In *Design Research*, researcher in the field of design and social context Peter Downton’s central proposition is that “design is a way of inquiring, a way of producing knowing and knowledge.” He proposes that design is therefore a way of researching. According to Downton, much work still needs to be done constructing arguments for this seemingly logical proposition—an effort in which a central role will be played by the debate on knowledge and ways of knowing (Downton 2003, p. 2).

Within Sint-Lucas, research-by-design now maintains more than one posture as well. This multiplicity is also reflected in the supportive structures set up to underpin the developing research milieu. From 2006 on, with inspiration from the former head of Sint-Lucas, Johan Verbeke, a set of research training sessions (RTS) was organized to enculture teacher-practitioners in design research. The RTS program involved sets of guest professors, each speaking from particular and sometimes opposing perspectives and associated research programs. For some, the fact that research-by-design is grounded in practice required a radical break with the more established ways of conducting research. Here the opinion prevailed that it should carve its own path strictly by its own means, modes, and methods. In my understanding, such a stance is all too defensive, dissociative, and therefore possibly infertile. It misses the point that, as researcher of cultural history Christopher Frayling and others have suggested, there is instead “a continuum from scientific research to creative practice” (Frayling et al. 1997, p. 15). The capacity of design and practice as knowledge-producing phenomena is being acknowledged more frequently now and has been demonstrated at many occasions. Within Frayling’s continuum, the architectural researcher will have to negotiate a position by crafting and assembling a unique methodological approach. In this assemblage, methods are created as well as borrowed from other disciplines.

(2) an artifact-driven methodological approach embedded in a landscape of knowledges

I have from the outset aligned with more inclusive conceptualizations of research-through-practice. One of these I encountered in Dunin-Woyseth and Nilsson, who in tandem have operated as guest professors in Sint-Lucas’s RTS program. Their conceptualization of research-through-practice has influenced me to position my research in a collaboration with Chalmers University of Technology, Department of Architecture and Civil Engineering, to which both Dunin-Woyseth and Nilsson were at that time connected. Together with many others, they have on the one hand insisted on the “craft aspect” and the “making

aspect” as “a core focus of the design-related research” (Dunin-Woyseth & Nilsson 2011). Crafting and making here constitute the methodological vehicles for spawning new knowledge. Insights come about through crafting artifacts and appear even in the form of crafted artifacts. Adding to this, Borgdorff has identified experimental making activities as well as the active involvement of the practitioner as simultaneously “the subject matter, the method, the context and the outcome of [...] research” (Borgdorff 2010, pp. 46, 57). In this multiple sense, two sets of co-authored and co-constructed artifacts and their making are propellants, each set corresponding to a specific experimenting ground (complicating machines or interiors in Chapter 1, walled artifacts in Chapter 2).

On the other hand, Dunin-Woyseth and Nilsson have encouraged design research to “engage in a dialogue with other knowledge producers, including those from more traditional academic fields, as well as from other realms of endeavor” (Dunin-Woyseth & Nilsson 2011). They have insisted on the fruitfulness of exploring broader knowledge landscapes or a broad landscape of knowledges (Dunin-Woyseth & Nilsson 2006, p. 169; 2009, p. 44; 2011). Indeed, architecture as a method works in an argumentative way (Dunin-Woyseth & Nilsson 2012, p. 43), but it is only one way of arguing. This implies that, as stated by Frayling, research-through-practice substantiates knowledge only “partly by means of practice” (Frayling et al 1997, p. 15). In the wider landscape, different ways of knowing cross with one another and influence research trajectories while being assembled. While designerly ways of knowing among practitioners and the “know-how of lay-people” (Forty et al. 2006, p. 42) increasingly join such trajectories, traditionally established ways of knowing and ways of conducting research remain ultimately relevant. That said, ways of knowing such as “skill”, “acquaintance”, “insight”, and “comprehension” gain importance on the scene of knowledge production, Borgdorff notes. The emphasis accordingly shifts from obtaining a rigid “explanatory grip” on a subject matter to a “perceptive, receptive, and *verstehende* engagement” with it (Borgdorff 2010, p. 55, original emphasis).

(3) an experience-driven methodological approach;

Given the focus on *encounters* and *making* in my research, I align with those strands of research that dedicate a central place to *experience* in knowledge production. According to Borgdorff, experience, and how it becomes enhanced through an accumulation of knowledge and skills, is a consequence of “action and practice, plus apprehension through the senses” (Borgdorff 2010, p. 55). In the realm of design research, this accumulation is often situated in the designer interacting with his or her designs. One might think of philosopher Donald Schön’s notion of *The Reflective Practitioner* (Schön 1983). In the research I developed, artifacts have been designed in order to further the investigation at hand and develop (situated) knowledge. But the accumulation of experience is consciously intensified by going beyond the one-on-one (designer-designed) interaction and constructing artifacts that are intentionally *out there* in the urban reality, thus enabling

real encounters to unfold, ideas to emerge, and action to be taken. Artifacts as methods add experiences to experiences, expanding the registers of what one knows experientially. This ability of designed artifacts to produce knowledge through accumulating and comparing experiences is also emphasized by Gerard De Zeeuw, a scientist and researcher of design research who notes the “channeling” capacity of artifacts (De Zeeuw 2011).

(4) a methodological approach including embodiment, emotionality, deliberate ambiguity, and situated inquiry;

According to Law, one needs to shift one’s understanding of research methods when addressing realities, because traditional methods miss out on some of the “textures” that make up those realities. “We will need to teach ourselves to know some of the realities of the world using methods unusual or unknown,” he emphasizes (Law 2004, p. 2). In my understanding, the unusual here refers to gaining knowledge through ways normally not even considered to be methods. Using methods unusual or unknown might imply that methods have to be imagined and constructed, often alongside the investigation and practice at hand. With regard to an expanding interpretation of what methods are, Law explicitly refers to the exploring and sensing body, pairing body-processes with ways of knowing. Knowledge can be gained through “embodiment”—through the “hungers, tastes, discomforts, or pains of our bodies.” It can happen through “emotionality” and “apprehension”—through “sensibilities, passions, intuitions, fears and betrayals.” We can acquire knowledge through “techniques of deliberate imprecision,” including “the indistinct and the slippery without trying to grasp and hold them tight.” And it can happen through—and only through—“situated inquiry” (Law 2004, p. 3). Law gives a taste of the range of methods conceivable: “musical performances; surgery; sport; physical lovemaking; games; model-making; architectures; cities; films and documentaries; prayer; physical exercise; collages and pin-boards; dance; masque; driving; cooking; flanerie; sculpture; natural phenomena of all kinds; gardens; and landscapes. And no doubt a lot more besides” (Law 2004, p. 146). Architecture itself is thus specifically named by Law as a method that helps address the full and complex textures of reality. To revisit the characterizations of the research-through-practice approach laid out so far, the artifacts developed and deployed invoke the ways of gaining knowledge introduced by Law. In encounters with those artifacts, bodily and sensory performances have often led to performances of making sense, thus enabling new insights to surface. The artifacts deliberately introduce degrees of ambiguity, so that acts of making sense become possible and probable. All artifacts have in their development and deployment been used as vehicles to develop insights in situated ways.

It should be noted that while I am trained as an architect, my teaching practice at KU Leuven Faculty of Architecture / Sint-Lucas has always been situated within the Master of Interior Architecture program. As I’ve mentioned, in that program an *embodied perspective* has always been considered pivotal and

a distinguishing characteristic in comparison to many other architectural focuses and approaches. I would argue that this embodied perspective, typical of the interior architecture approach, is closely related to Law's idea of knowing and gaining knowledge through embodiment and emotionality (affect).

(5) a slow methodological approach of pragmatic, constructive design research;

In his argument for broadening or reinventing the notion of method, Law has intriguingly proposed the idea of a “slow” method. Methods that invoke a dynamic that “takes longer to understand, to make sense of things” (Law 2004, pp. 10–11). Drawing on the above paragraphs, I consider the methodological approach used in my thesis to be related to that idea. It works through the making and encountering of artifacts, and through provocations of sense-making processes in those encountering them.

In fact, architectural practice itself always is a painstaking, slow, and messy process that moves through many detours. Arguably, this aspect is also typical of what is called “constructive design research.” This is the kind of design research that puts construction at the center of a pragmatically driven construction of knowledge, exploring the area “halfway” between people and things (i.e. “interactive design”). The sociologist and researcher in the field of industrial design Ilpo Koskinen and others have documented constructive design research in the settings of lab, field, and showroom (Koskinen et al., 2011). I wish to add to these settings that of the construction site or wharf conceived at all kinds of scales—a socio-spatial construction site that connects to many actors and that itself is constantly in the making. Some of these sites have been connected to educational contexts. Some have been connected to the architecture firm I collaborate in. But all have been developed deliberately as construction sites that aspire to *qualitatively slow* progress.

In the following paragraphs I want to make the preceding quite general traits of a research-through-practice approach more specific, aligning them more with my own orientation and aspiration. When speaking of knowledge in the above sections, the kind of knowledge I have in mind is in line with what Groat and Wang call the “relatively small increments of knowledge attained through a variety of means” (Groat & Wang 2013, p. 8). Revisiting the above reasoning, however, these small increments and the methods bringing them to life are able to produce (alternative) realities and worlds, or at least reveal latent aspects of these. John Law comes close to this in writing of (designerly) methods as re-crafting activities from a “hinterland of realities,” creating “new versions of the world.” A method “makes [...] new manifestations and new concealments, and it does so continuously” (Law 2004, p. 141). The idea he's illuminating here is ultimately important. It acknowledges that methods themselves are performative and creative and not just procedural applications. Methods don't merely assist in understanding reality as it is; on the contrary, they are themselves active agents. They gather or arrange things;

they conceal parts of reality or reveal latent aspects of it. Again, a correlation can be perceived here between the micro and macro levels of my research, between the artifacts it develops and its methodological approach. As Law emphasizes, every such act of arranging has “political implications” (Law 2004, p. 141).

(6) a political methodological approach of reality-making;

Research-through-practice deployed as a methodological approach has naturally political implications. In *The Science of Artificial*, cognitive psychologist Herbert Simon states that while academic science disciplines focus on “how things are,” design practice (and related activities) aim more at “how things ought to be” (Simon 1981, p. 129). Design and research-through-practice make projections of how things can be through spatial projects, thus making alternative realities present. In this sense, research-through-practice is a political, projective, methodological approach oriented toward achieving some degree of change within reality. My research largely revolves around a political projective capacity of artifacts, which are seen as methodological vehicles for that purpose. In so doing, my research also imports ideas about the political and about reality-making developed in other disciplines.

Research-through-practice as a methodological approach and crafted artifacts as methodological vehicles thus perform in political, projective ways. I have conceived of the artifacts embedded here accordingly. As Law emphasizes, there is no such thing as one universal reality; realities have to be “practiced” (Law 2004, p. 15)—they have to be practiced by the one conducting research-through-practice in search of new ideas. But just as importantly, they have to be practiced by those entering the artifactual stages laid out by the research-through-practice activity in urban reality. Besides these, I have also aimed to explicitly affect those encountering the architectural artifacts in educational contexts, actively drawing them into the (politics of any) making activity. The aim, then, has been to affect their attitudes with regard to architectural creation.

The emphasis here on the political and projective adds to why I have chosen to position my research in a collaboration with Chalmers University of Technology, Department of Architecture and Civil Engineering. As has been brought to the fore by Dyrssen, artistic research here resonates with a set of tendencies shared in the wider (Swedish) research community. The focus here has shifted “from reflections on the artists’ creative processes to a renewed interest in art-related materiality and agency”, to research themes “driven by complex art-society issues related to capacities, possibilities and agency of artistic production and modes of investigation,” and to ways of not only using “theory projected from other domains [...] but to develop theory and conceptualisation through artistic approaches and practices” (Dyrssen 2017, p. 176, citing from a 2015 Swedish Research Council report).

(7) a new, performative and nomadic methodological approach;

While Law gives many suggestions for broadening the understanding of what method is, he has moved one step further, suggesting that the notion of knowledge and gaining knowledge as the driving metaphor and aim of research is to be replaced (Law 2004, p. 3). This implies taking into consideration other metaphors and aims. As I've already mentioned several times, I have followed first and foremost an explorative path initiated in and addressed through practice as a base. Sociologist, philosopher, and historian of science Andrew Pickering's distinction between "representational perspectives" and "performative perspectives" on research activity comes to mind. While representational perspectives aspire to mirror reality, cutting it up and producing knowledge about it based on facts, performative perspectives take all kinds of agencies, traversing reality as their base. Research, then, is essentially an activity of coping with human and material agencies, as noted by Pickering (Pickering 1995, p. 21). To this, as Nilsson points out, also philosophers Deleuze and Guattari's distinction between "nomad science" and "royal science" can be added (Deleuze & Guattari cited in Nilsson 2013, p. 135). While royal science focuses on the production of knowledge, nomad science is instead concerned with "producing change, transformation, the making of new worlds"; it "explores the world by travelling through it, with the material," "close to the material, tactile and manual ..." (Nilsson 2013, p. 135). Deleuze and Guattari propose their distinction by stating that these approaches work in concert. For the realm of design research, according to Nilsson, it follows that "they provide different perspectives using different attitudes and modes of thought, putting more abstract ideas and norms in relation to material thinking, processes, actors and objects" (Nilsson 2013, p. 136). The artifacts of my research have in that sense fused abstract ideas, shared across disciplines, with the concrete actions of human actors and the concrete life of material artifacts.

In the above discussion, design (practice) is once more confirmed as a method for driving research efforts. Connecting again to the notion of knowledge, many authors have reported on design research as a new mode of knowledge production. This "post-academic" (Ziman 2000), "Mode 2" (Gibbons et al. 1994) kind of knowledge production and affiliated research shares many characteristics with traditional, academic science. There are fundamental differences, though, such as the aforementioned emphasis on transformation and change—enough to make mention of a *new* culture of knowledge production. Characterizing Mode 2 knowledge production, Michael Gibbons and others have spoken of it as "transdisciplinary," emphasizing social accountability and evaluating itself on the basis of actual usefulness (Gibbons et al. 1994, pp. 3, 167). Pursuing transdisciplinary investigative efforts necessarily implies that one steps out of the confinement of one's own discipline and practice in order to face—together with multiple other agents and while crossing disciplinary borders—the actual challenges and calls raised within reality. This explains again why I have opted to

answer to actual calls, including those formulated from outside the field of architecture. Such calls are set in “contexts of application” (Gibbons et al. 1994, p. 167) involving real participating people bothered with real-world problems.

(8) a methodological approach that makes matter matter;

Research-through-practice approaches pair matter with more abstract ideas. Various kinds of knowledge are deployed in this process—skill and situated knowledge, but of course also conceptual kinds of knowledge and the more propositional kind of knowledge associated with building activity. In addressing socio-spatial challenges, the contribution of architecture and architectural materiality is considered relevant and partially unique. Connecting back to Law, an architectural approach is able to capture some of the *textures* of reality that are overlooked by traditional methods. I specifically think here of its modes of substantiating, of making sensible, of spatializing, and of mattering. In a co-authored paper, Janssens and I have accordingly elaborated on the inseparable twin matter. We conceived of it as making matter by bringing into substance intertwined with making matter by being or becoming relevant to the world and reality. We insisted accordingly on a shifting of the attitude of designers with regard to the critical and political potential of architectural design. We called for “a critically questioning design attitude inducing the dynamics of negotiation” (Liekens & Janssens 2011).

I will advance some of the voices attributing architecture with such unique qualities of substantiating, and call upon it to deploy more consciously these qualities in shared socio-spatial challenges. These voices have noticed, as Law puts it, that their own ways of gaining knowledge are somewhat “materially restricted.” Methods such as architecture, then, might serve as “an allegory for, resonate with and help to craft a particular reality” (Law 2004, pp. 146–47). Architecture as a method introduces another kind of materiality or “presence” to the notion of method—a presence that is “other than those [...] currently privileged” (Law 2004, p. 153).

It is clear in the above that the method of crafting architectural artifacts, considered here as a way of crafting a particular reality, gives substance itself to the idea of the poetic (making) architectural instrument. Operating as *substantial methods*, the artifacts of my research, in being made and being encountered, are then able to alter many things. They can change the way reality and the world are understood. In parallel and through practice(s), they can shift the very understanding of what an artifact is and how it can be deployed. This is relevant for the profession of architecture, supplementing it with a particular efficacy. In addition, it has been my assumption that it is ultimately relevant for the realm of architectural education. Future practitioners can and must be trained in the critical, political, and ethical potential of architecture and architectural practice. It follows that the milieus of practice and education have been experimenting grounds in that sense.

(9) a design-polemical projective methodological approach;

At this point I wish to refer to a sub-position within the developing research culture at the Sint-Lucas School of Architecture / KU Leuven Faculty of Architecture, where my research has been based. I refer here to the Radical Materiality Research Group (RadMat). RadMat's mission statement asserts that in putting architectural materiality at the center, one of its aims is "to substantiate a recurrent fascination for matter as an active agent in the design process and for how matter and the process of generating ideas and artifacts in-form one another" (RadMat Research Group mission statement).

In my understanding, RadMat productively puts in tension slightly different interpretations of this focal interest. Simplifying the distinction reverts to how the notion of generating ideas is posited. Some RadMat perspectives mainly emphasize the generation of ideas understood from the perspective of sensation and affect, which reside more in the here and now. Other projects also consider the generation of ideas from the perspective of societal impact and change—from the perspective of the *future*. As an exponent of this latter current within RadMat, Janssens has in her research proposed the notion of projective research, an approach that pre-figures alternative futures through spatial projections (Janssens 2012, pp. 209–12). Aligning with this, Nilsson has mentioned with regard to design research a making that is an "actively doing, modelling, altering things in a mode which simultaneously engages thinking and ideas about future worlds as well as the practical transformation of present materials" (Nilsson 2013, p. 127). Groat and Wang have identified Janssens's approach as specifically emphasizing the "deontological nature of much of architectural practice" as well as the "deontological nature of practice-based design-polemical theorizing" (Groat & Wang 2013, pp. 54, 130). I associate my research with this specific track within RadMat.

2.2. DIAGRAMMING DESIGN RESEARCH

In the above discussion, *research-through-practice* is specified as the core methodological approach of *Architecture's Poetic Instrumentality*. That said, the approach is essentially an assembled one. There is an interweaving with methods from established research traditions (mode 1). I will now position my research by using two frequently used ways of diagramming design research methodologically. First, I will specify a version of Groat and Wang's nested set of four levels, providing together a "conceptual framework for situating methodology in research" (Groat & Wang 2013, pp. 9–13). Here any research project can be situated on logically interconnected levels, spanning from a more general positioning to the level of specific research tactics. Connections can be made here between design research and the "modes of research from non-design disciplines," thus opening up design research more comprehensively to wider and interdisciplinary audiences (Wang 2007, p. 42).

Consequently, the methodological approach here will be mirrored to researcher of interaction design Daniel Fallman's interaction design research triangle (Fallman 2008), recapturing some of the characteristics delineated in the paragraphs above. In this way of diagramming another rationale is followed. The emphasis is on substantiating a unique position for each specific design research between the extremes of "design studies", "design practice", and "design exploration". Retrospectively, I am particularly drawn to Fallman's way of diagramming design research, because it allows for a positioning that substantiates the aforementioned important pairing of an explorative attitude with a firm grounding in design practice.

2.2.1. _ *Groat and Wang's nested set of levels positioning design research*

Groat and Wang make distinction between four interlacing levels:

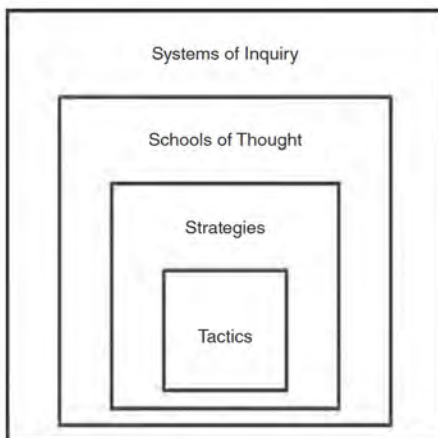

Figure 0.11: *The nested set of levels positioning design research, 2013. Diagram: Linda Groat and David Wang, published in Architectural Research Methods.*

(10) systems of inquiry: an intersubjective approach of reality

The level enveloping all other levels is that of a research's "systems of inquiry." This level advances the paradigm or worldview from which researchers approach reality. As Groat and Wang state, "everyone who conducts research is making assumptions about the nature of the world and how knowledge is generated" (Groat & Wang 2013, p. 63). Historically, there have been dichotomous distinctions between *subjective* and *objective*, between *qualitative* and *quantitative* systems of inquiry. Groat and Wang counteract these dichotomies by proposing an interstitial position called "intersubjective." The intersubjective recognizes a "multiplicity of distinct perspectives" on (social) realities. It recognizes both the importance of socially shared action and of understanding these realities (Groat & Wang 2013, pp. 76, 78). Groat and Wang consider the intersubjective approach to reality to be specifically relevant for architectural research. It could be used to elucidate individual and collective interpretations of architectural artifacts or to explore "contested dynamics" within design processes (Groat & Wang 2013, p. 78). The artifacts operating as the stages of my research resonate with this kind of approaching reality. Adding to this, I argue that the research-through-practice approach used here is itself part of the level of systems, since it conceives of design and design practice as knowledge-producing phenomena.

(11) schools of thought: the double capacity of critical / transformative and pragmatic / suggestive perspectives

The level of "schools of thought" foregrounds broad theoretical perspectives that influence a research (and a discipline). Here I consider this level to be defined by both critical

and pragmatic perspectives. With regard to this seemingly irreconcilable pairing, I refer again to Dyrssen’s foregrounding of a double capacity inherent in design, which pairs the critical with the suggestive. Attesting to this double capacity, my research inscribes itself in the larger effort that aims “to provoke changes in the values, attitudes and practices of architecture as it is currently conceived and practiced” (Groat & Wang 2013, p. 95). It does so in pragmatic and suggestive ways, producing “practical knowledge” that enables “the cultivation of social relationships” (Groat & Wang 2013, p. 92). The double capacity of being “critical / transformative” and “pragmatic / suggestive” will repeatedly take the stage throughout what follows.

(13) the tactics of an architecturally-framed, auto-ethnographic inquiry and the tactic of thick description, positioned in a framework of (12) qualitative research strategies

The level of “strategies,” according to Groat and Wang, addresses “the skillful management and planning” of a research project. Interlaced with it, the level of “tactics” points out its “skillful moves”—the “more detailed deployment of specific techniques” (Groat & Wang 2013, p. 10).

In *Diagramming Design Research*, Wang identifies most of design research as following “qualitative research strategies” using multiple tactics (Wang 2007, pp. 37–38). He goes even further, suggesting that in some cases the category of qualitative research strategies can easily be replaced by the category “design” itself. In these cases, “it is [...] design that will culminate the research” (Wang 2007, pp. 40, 41). I subscribe to this reasoning.

Wang interlaces the category of qualitative research strategies (or the category of design) with several specific (qualitative) research tactics. Two of them have been adopted in my research in an interpreted version. These are the tactics of “ethnography” and “thick description”. Significantly, it is only these two tactics that in Wang’s scheme perfectly match the category of qualitative research strategies or design (Figure 0.12).

In the scheme, other tactics such as “participant observation” and “artifact analysis” are also associated with other (non-qualitative)

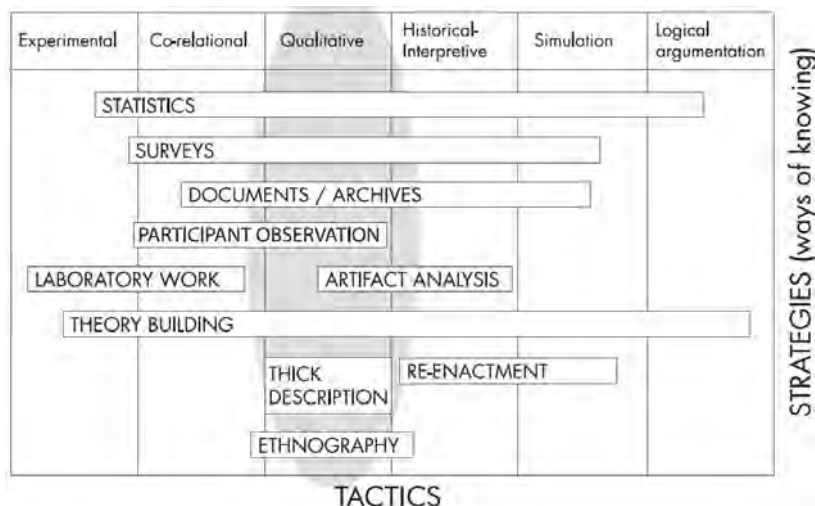

Figure 0.12: The interlacement of the levels of research strategies and tactics, 2007.

Diagram: David Wang, in *Diagramming Design Research*.

research strategies. While these tactics have surely influenced my research too, they have not been among my primary methods.

I propose a reworked version of the tactic of “ethnography”. The necessity for such a reworked version can be seen announced in Borgdorff’s observation that design research often deals with an essentially “enacted approach,” with “experiences and insights [...] embodied in [...] practices and products.” Experiences and insights that are “pre-reflective,” “non-conceptual” and “non-discursive,” and therefore embodying knowledge “in a form [...] not directly accessible for justification” (Borgdorff 2010, p. 47). During the research, I have implicated a variety of agents in the making of artifacts: students, colleagues, neighbors, the contingent passer-by, me, matter itself. In ethnographic tactical approaches, the one observing and analyzing participates as well, while maintaining a distance to the “tribe” of agents. In addition, there is no common language with the agent matter except that of experience. Therefore, I have deployed what others have referred to as “an architecturally-framed auto-ethnographic inquiry.” In the current of narrative research, “auto-ethnography” is conceived as building on the tradition of ethnography, but taking the researcher’s own lived experiences, thoughts, and behavior while living in situations at the center of observation (Chang 2008). I have consciously interwoven in the research some moments of re-drawing and re-modeling, as such giving substance to this auto-ethnographic approach of the encounters with the artifacts. These instances of re-drawing serve as personal ways of re-collecting and re-imagining, presented in turn to the reader for interpreting and making sense of what was seen and experienced by the researcher him- or herself (Connelly & Clandinin 1990, p. 8). What makes the auto-ethnographic tactic specific here is that it is an architecturally-framed version, followed through by means of drawing and other architectural modes rather than only through precise verbal description.

Interlaced with this approach, the tactic of “thick description” has been deployed also. Each of the main chapters is characterized by the thick description of a protagonist artifact (CoMa₀₂ in relation to an educational experimenting ground, the Walled House in relation to the experimenting ground of an architectural practice). En route, these thick descriptions are further thickened in a narrative that interweaves adjacent practices and ideas.

In Wang’s scheme, one tactic is associated with all possible research strategies—the tactic of “theory building.” I have touched upon the idea of theory utilized within my research and will reconnect to it when plotting positions within Fallman’s diagram.

Thinking retrospectively of the positioning of my research with regard to Groat and Wang’s scheme of the four interlaced levels of research, in my understanding the main methodological approach of research-through-practice operates on all four levels. Indeed, it constitutes ideas on what knowledge is and how it is produced and shared. There is indeed a double capacity of being suggestive while critical. Design as a category itself can indeed replace the category labeled as “qualitative research strategies.” And of course design can be framed as a research tactic, argument, or vehicle.

2.2.2. _ Daniel Fallman's triangle of design practice, design exploration, and design studies

In the realm of interaction design, Daniel Fallman has developed a diagram for positioning design research between the extremes of “design practice”, “design exploration”, and “design studies”. My research here in architecture can be productively reflected in that diagram, engaged as it is with, in Fallman’s words, “the relationship between designed artifacts, those that are exposed to these artifacts, and the [...] context in which the meeting takes place” (Fallman 2008, p. 4). In this, several of the issues and characteristics already discussed can be interwoven. I will mainly emphasize the extremes of design practice and design exploration, since they foregrounded earlier as important characteristics of the background and methodological approach of my research. In fact, their presence has been one important reason for specifically adopting Fallman’s diagram. While emphasizing these two extremes primarily, I have also engaged with the extreme of design studies—as in my engagement with existing ways of conceiving of design and designing, or in the contribution to shared agendas.

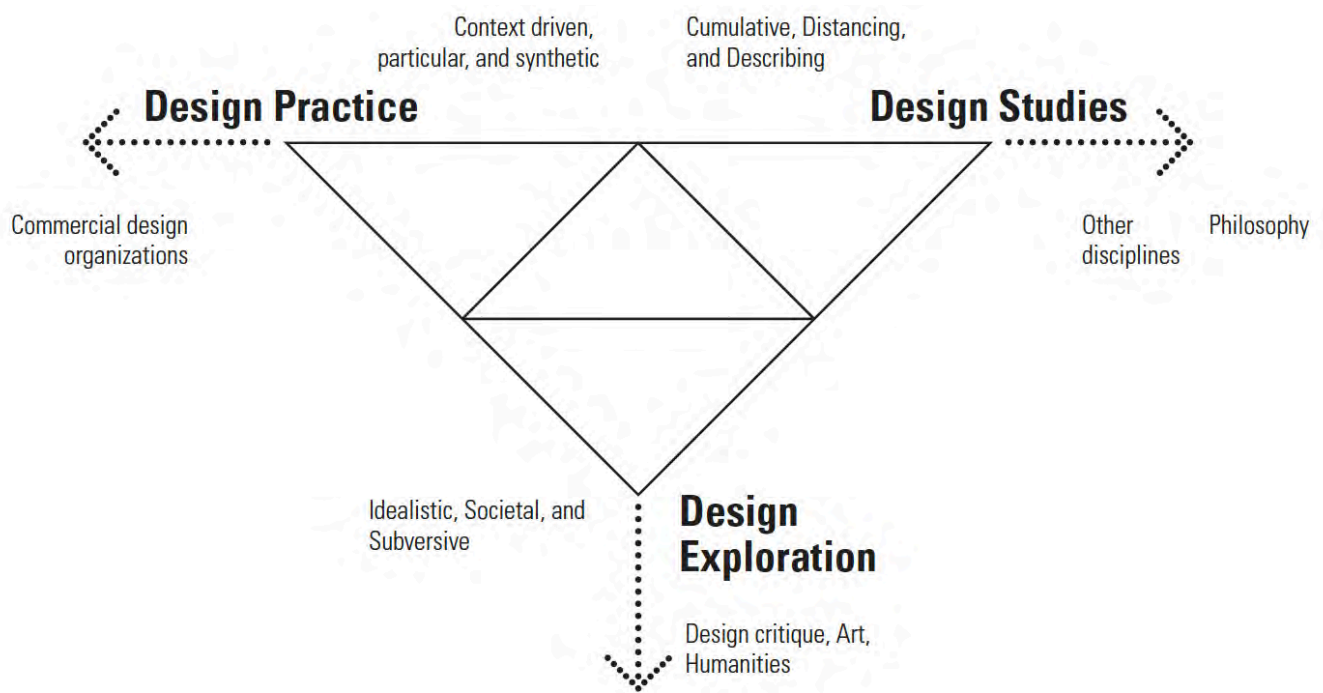

the extreme of design practice

With the extreme of design practice, Fallman is referring to those activities that are usually practiced outside of academia. Drawn to this extreme, a researcher connects to the “tacit knowledge” and “vital competence” involved and transmitted in the creation of artifacts—that is, the knowledge and competence of “actually putting things together, shaping the form of something new” (Fallman 2008, p. 6). As suggested before, such knowledge and competence flourish from a deep involvement and cannot be obtained from distant perspectives. It follows that Fallman identifies the kind of knowledge produced here as

Figure 0.13: The general version of the interaction design research triangle, 2008. Diagram: Daniel Fallman, in *The Interaction Design Research Triangle of Design Practice, Design Studies, and Design Exploration*.

“engaged knowledge” (Fallman 2008, p. 7). The notion of engaged knowledge relates to what was defined above as an “enthusiasm of practice,” on which my research was founded. Fallman notes that at the extreme of design practice, design researchers are encouraged to formulate research questions from their activities. They formulate them within contexts of application, making them more “proactive” than “reflective” (Fallman 2008, p. 7). Fallman adds that a research agenda is pushed here that seeks to actively “change how a specific design technique is used.” Fallman’s idea is closely related here to the idea of re-conceptualizing the architectural artifact as a poetic instrument.

the extreme of design exploration

In *Architecture’s Poetic Instrumentality*, a speculative, proactive track of crafting architectural artifacts has been set up to interrogate commonly accepted assumptions. This interrogation is characterized by *What if?* questions, the type of questions that Fallman categorizes under the *extreme of design exploration*. The interrogation further assembles a landscape of thoughts and practices. In this respect, it relates to what Fallman proposes as another aspect of the extreme of design exploration: its affinity and interplay with “theories and alternative foundations for design” (Fallman 2008, p. 8). In Haseman’s words, “as the researcher practices, a web of connections and links becomes evident to build a rich and layered analysis of the contexts of practice within which the practice-led researcher operates.” What comes into being is a web of connections rather than “a deliberate and systematic map of the field” (Haseman 2006). While artifacts started developing from an intuition *in* practice, pushing in turn a research agenda along explorative vectors, the crafting of the artifacts immediately and increasingly also became embedded in a heterogeneous web of connections. That web involved the intertwining of cases, ideas, and theories from disparate fields that were all engaged with similar concerns.

The notion of a productive interweaving with and contribution to theory is reason to briefly consider the third of Fallman’s extremes. At the extreme of design studies, according to Fallman, research activities are concerned with making (more general) contributions to “an accumulated body of knowledge” (Fallman 2008, p. 9). As suggested in this study, such contributions have been made.

Fallman situates the possibility of critique, provocation, and politics within the extreme of design exploration (Fallman 2008, p. 8; diagram p. 14). This is of importance here since these notions have marked its path and its protagonist artifacts—artifacts that embody critiques, radiate their provocative personality, and instigate political manifestations. The extreme of design exploration also displays affinities with “the interpretative attitude of many humanities disciplines,” Fallman suggests (Fallman 2008, p. 8). The aforementioned incorporation of methodological approaches such as thick description and (auto-)ethnography are symptoms of this.

navigating within Fallman's diagram

A peculiarity of Fallman's diagram is that it avoids taking a position at one of the extremes. Instead, it suggests that interaction design research unfolds in a continuous "drifting" activity between the extremes. The drifting here comes as a constant change of perspective and with it a change of tradition (and, arguably, a mixture of methods). As Fallman emphasizes, there is no change of practice (Fallman 2008, pp. 10–11). Thus, a design research project is not identified with one of the extremes, but runs constantly between them. Practicing design research, a single researcher undergoes different exposures, including "first-person perspectives" (Fallman 2008, p. 17) that nurture the inquiry. As Fallman suggests, this peculiarity of the diagram is what sets it

Figure 0.14: Specifying Fallman's interaction design research triangle: the delineation of my research project's dimension, navigational trajectories and loops in-between extremes. Adjusted diagram: Johan Liekens.

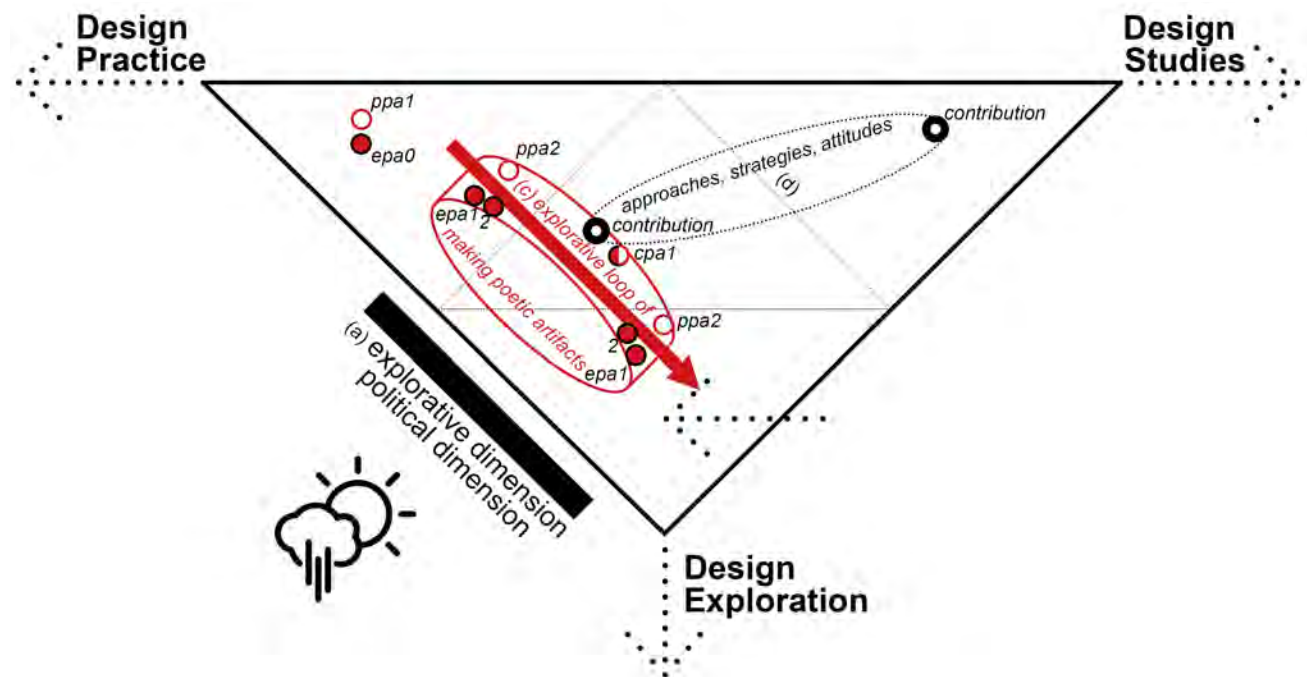

			↑ relative weight	
experimenting ground 1	>	epa1	●	CoMa ₀₁
	>	epa2	●	CoMa ₀₂
	>	epa3	●	CoMa ₀₃
	>	epa4	●	CoMa ₀₄
	>	epa5	●	CoMa ₀₅
experimenting ground 2	>	ppa1	○	<u>Hogeweg</u>
	>	ppa2	○	Walled House
	>	ppa3	○	Landscape of Refugees
experimenting ground 3	>	cpa1	◐	<u>Research Studiolo</u>

apart from other influential schemes that intend to position design research. Fallman refers to Cross's scheme, wherein the categories of "design epistemology", "design praxeology" and "design phenomenology" still mainly describe and observe design from a certain distance (Cross 1999, pp. 5–10). These are similar, one could argue, to Fallman's extreme of design studies. Instead, Fallman proposes an active research trajectory that oscillates between extremes and renders design research, according to Fallman, more qualitative and relevant. It enables researchers to arrive at findings normally unattainable when occupying merely one of the extremes or observing from an outside perspective (Fallman 2008, p. 17).

Fallman proposes three techniques to navigate research activity within the diagram. He distinguishes between "trajectories", "loops", and "dimensions" (Fallman 2008, pp. 10–11). I am specifically interested in the technique that attributes to a specific research a particular dimension (14) (a). In Fallman's diagram, such a dimension figures in the form of a thick black line placed peripherally to the diagram. As already mentioned, my research has developed in a milieu where an explorative attitude has traditionally been fostered, combined inseparably with a firm grounding in practice. Thus, I would like to label the dimension of *Architecture's Poetic Instrumentality* as *explorative*, while placing the thick line in the direction of the extreme of *design practice*. It is, in Fallman's terminology, a dimension of provocation—of transcending current paradigms, of suggesting alternative interpretations and futures. It is a dimension of making a sun appear from behind a cloud (Fallman 2008, p. 12). It is, according to Fallman, also a dimension of the "political", aligning with the political (and critical and ethical) in my research, as an invigorating aspiration to "strive to change and create something new" (Fallman 2008, p. 15). Notwithstanding the clear potential of this specific dimension, Fallman has claimed that surprisingly few design research projects use it. I want to make a contribution to rectifying this deficiency.

Fallman introduces the concept of trajectories and loops to delineate the aforementioned shifting of perspectives, exposures, and traditions. While trajectories point at a shift in a one-way direction, loops point more to an ongoing shifting of perspectives. Thus, loops more convincingly represent the research activity as a continuous drifting between.

In order to be able to delineate the trajectories and loops, I have added a second scheme to Fallman's diagram that shows the co-authored architectural artifacts developed. I have sorted them in three categories, referring to the three different design practices and experimenting grounds: the category of propelling poetic artifacts developed through educational practice (*epa*), the category of poetic artifacts developed through professional practice in our architecture firm STUDIOLOarchitectuur (*ppa*), and the third experimenting ground associated more with craft (*cpa*). I have also attributed a certain weight to these poetic artifacts by means of red circles sized according to their importance within the research. The numbers added to the different *epa*, *ppa*, and *cpa* artifacts correspond to the sequence of

their making. It thus becomes clear that the main protagonists overall have been *epa2* and *ppa2*, closely followed by *epa2* and *cpa1*.

After having indicated on the periphery of the diagram the exploratory and political dimension of my research (14) (a), some of the propelling poetic artifacts can already be positioned. I partially recapture here the narrative of this introduction, mapping it onto the diagram. Throughout the making of these first artifacts, in collaboration with others, I aspired to alter the usual perspectives on how architecture is practiced. In education, I proposed the CoMa/CoIn design studio to reorient the educational practices I had been engaged in before entering an explicit research trajectory (labeled *epa0*). I also position *ppa1* (the Hogeweg project) here, because at the time of its design a focus on the artifact's own poetical production was present in the background. I position these artifacts close to the extreme of design practice—of practice as it is usually conceived and executed. Subsequently, following a renewed enthusiasm of architectural practice triggered by an emergent sense of problem, I co-substantiated three more poetic artifacts, which I add to the diagram. Here, a movement can be perceived toward the extreme of design exploration. In the diagram I have marked this movement with a thick red arrow, representing a first navigational trajectory: an explorative trajectory (b). The artifacts added in this trajectory are *epa1* (CoMa₀₁ Ont-moetingsmeubel), *epa2* (CoMa₀₂ Confusion-by-Cooking) and *ppa2* (the Walled House project). Drawing this first arrow or trajectory in the direction of the extreme of design exploration in itself was a necessary operation in order to accord more generally with the explorative and political dimension of my research.

I soon fused this first arrow with a thick red loop (c). Coinciding with the trajectory, it also spans the territories of design practice and design exploration. With this loop I want to accentuate the oscillation between the perspectives of practice and exploration that characterized the making activity of the artifacts. Designing in that looping movement has changed my / our design practice on all experimenting grounds.

I thickened one half of the loop to create a pinkish surface that I consider to be the territory of all poetic artifacts developed here. I will not specifically attribute each artifact to a position. I have positioned the *epa* artifacts on the left of the pink surface, the *ppa* artifacts on the right. I positioned *epa1* (CoMa₀₁ Ont-moetingsmeubel) and *ppa2* (the Walled House project) still within the territory of design practice but already drawn towards the extreme of design exploration. I added them a second time to point out that they have moved in their development back and forth between the two extremes.

From within the loop delineating the enthusiasm of practice making poetic artifacts, a second loop (d) is added to the diagram, moving to the extreme of design studies. As mentioned before, drawing on existing theories from other practices and disciplines, some practical and theoretical concepts have entered the investigation and reasoning. They have fertilized, so to speak, the exploration at hand. Some findings from this exploration also

return to the extreme of design studies, contributing by articulating insights. Such insights are for example the *approaches* (of architecture as a practice and an artifact, of reality and the impact of architecture on it, of research-by-design, etc.), *strategies*, and *attitudes* this research will develop. I see connections here with Groat and Wang's statement that "in architecture and allied fields, the likelihood is that research will more likely generate middle-range theory than big theory" (Groat & Wang 2013, p. 42). Hence, a dot marked with *contribution* is placed at the right end of this loop, delineating a contribution to design studies. However, this contribution cannot be dissociated from the landscape populated by thought, artifacts, and practices that in my research develops between the extremes of design practice and design exploration. On the first loop delineating the enthusiasm of making poetic artifacts, therefore, I have placed another dot which highlights an equally important contribution.

I noticed that Fallman's diagram enables design researchers to position their research to frame several of its characteristics. It does so without forcing a design researcher who also is a practitioner to become something other than an agent working in the tension between all extremes. The diagram's uniqueness is that it situates research activity as an ongoing practice running between and not as a fixed point at one of the extremes. The continuous shifting of perspective, exposure, and tradition brings with it an enrichment of the research, including its relevance.

★_3.

METHODOLOGICAL POSITIONING, IN A NUTSHELL

Condensing in a list the methodological approach pursued, it is a:

(a) *research-through-practice approach*, as:

- (1) *an explorative methodological approach operating from within practice;*
- (2) *an artifact-driven methodological approach, embedded in a landscape of knowing;*
- (3) *an experience-driven methodological approach;*
- (4) *a methodological approach that includes embodiment, emotionality, deliberate ambiguity, and situated inquiry;*
- (5) *a slow methodological approach of pragmatic, constructive design research;*
- (6) *a political methodological approach of reality-making;*
- (7) *a new, performative, and nomadic methodological approach;*
- (8) *a methodological approach that makes matter matter;*
- (9) *a design-polemical projective methodological approach.*

...that is:

(b) *nested in four interlacing levels of research:*

- (10) *systems of inquiry:* *intersubjective worldview;*

- (11) *schools of thought*: *(research-through-practice)*
combining a
critical-transformative approach
with
a pragmatic-suggestive approach
(research-through-practice)
- (12) *research strategies*: *qualitative research strategies;*
altogether replaceable by the
category
(research-through-practice)
- (13) *research tactics*: *architecturally-framed*
auto-ethnographic approach;
thick description
(research-through-practice)
theory building
(interwoven in the landscape)
literature compilation
(interwoven in the landscape)

...and most fundamentally has:

- (14) *an **explorative and political dimension**, mainly moving back and forth between the extremes of design practice and design exploration.*

With these introductory and methodological aspects in mind, I invite the reader of this thesis to engage with the poetic artifacts developed in my research and taste the textures of the landscape they have helped constitute.

CHAPTER 1

*exploring
a critical, political, and ethical capacity
of architectural artifacts
in the experimenting ground of the*

**CoMa/CoIn
DESIGN STUDIO**

★_4.

EXPLORING A CRITICAL CAPACITY OF ARCHITECTURAL ARTIFACTS

___4.1. AN ENCOUNTER WITH cOmA₀₁

An imponderable black I face within the surface of the wall bordering this corner house. My eyes try to adjust and measure its depth. Familiar with these streets, I am unacquainted with what seems to be this invitation to explore—this basic suggestion of an interior. At least, that is what I make of the situation I've just stumbled upon. I hesitate to enter, however. Just moments ago, I caught a glimpse of someone slipping into that black depth, giving me reason to approach, reason to stare and to gauge. Now my foot touches the black matter, becomes subsumed in it. I have left the street now and entered a new realm. At first the darkness is complete. Gradually my eyes reconstruct the contours of a bench in the lower part of my field of vision. Protruding from it, to the left and slightly off center, I hear something moving. A pair of legs just caught my attention. There is something curious and intimate about this situation that ultimately makes me move forward. Seeking a position on the bench, but wishing not to disturb whoever's legs these are, I suddenly become aware that the bench is slightly inclined. That fact, together with the smooth finishing of its surfaces, makes me drift to the center and thus toward the other body there. Trying to break that movement, my fingers touch the warmth of another hand. While harmless, the instance of touching feels proportionally magnified here. I stand up, feeling tricked by the bench's slippery slope, though admitting that the touch just increased my curiosity. Back on my feet, I decide to move toward a glimmer of light in the corner of my eye that announces another section of the space I'm in. Turning a corner, the light becomes more intense. I find myself enveloped in a wooden construct that stands out against the darkened background of the corner house's hull. The wooden planks are all I can see of this structure, which patterns the space in every direction. I find myself on an elevated stage now in the middle of the space I can perceive. From here I observe the variety of articulations inviting me, and apparently other bodies, to take in certain fixed positions. I spot a position in a niche-like space flanked by a vertical wall. I descend along the wall, entering the deepened niche, where I take my place and gaze back at the center stage. Then the stumbling sound of a body slowly closing in from behind the vertical wall draws my attention. Moving my eyes onto the surface of the wall, two distinct vertical cuts now become

noticeable within the horizontal pattern of the wood. I push on the surface between these cuts and a mechanism sets in motion the opening of a small hatch. Opening the hatch further with one hand, I stare into the cavity between the inner and outer surfaces of the wall. I realize that what I am staring at is my own face in a mirror mounted in the depth of the cavity. In the reflected fragment of my own face I see confusion. Suddenly the image trembles and moves outwards, making way within the same frame for another, unfamiliar face, accompanied by another, unfamiliar hand holding what seems to be a second and opposed hatch. An estranging symmetry becomes sensible. For a long moment I stare into two eyes tipped by the edge of a beautifully crafted pale prayer cap. The expression in the face I'm confronting is inquisitive. No words are exchanged, just this long moment of staring and trying to make sense. Having left a second time a position afforded by the material construct that distributes me and other bodies, I now ascend a staircase leading away from the central stage and upwards. Here another seating position fixes my body and with it my gaze, orienting it through a conic framing device on a fragment of the interior of an adjacent laundry shop. After witnessing this specific scene a while longer, a scene of people performing, lingering and waiting in the vicinity of a battery of washing machines, I think to myself that there is something intriguing about public spaces like this—these anonymous non-spaces of the city, which nonetheless serve as informal stages for unforeseen and potentially intimate encounters. These encounters happen, now that I think of it, against the background of the somewhat delicate treatment of the most intimate layers enrobing the human body.



Figure 1.1: Encountering Complicating Machine/ Complicating Interior CoMa₀₁ Ont-Moetingsmeubel, Studio CoMa/ CoIn 2009–10. Photograph: group CoMa/ CoIn 2009–10.



Figure 1.2: Experiencing and staging events in the city: speed-testing mock-ups as part of delineating complicating interiors in CoMa₀₁.
Photographic collage: Sanne Delecluyse, Jens Lippens, and Ellen Fievez.

In the spring of 2010, students in my design studio Complicating Machines / Complicating Interiors developed and deployed an architectural artifact like the one described above in a small urban corner house adjacent to the public space of Tolhuislaan, a street in Ghent. The project intended to involve—to complicate, so to speak—its passers by into a series of peculiar encounters. The scenario described above is only one of many possible scenarios, but it corresponds to one of the few pictures taken of the artifact in use (Fig. 1.1). It depicts an encounter between a young woman and an old man substantiated and framed by the artifact. The shortage of photographic documentation of the studio exercise hints at the fact that the ultimate encounter was more lived than systematically observed. This can be seen as a quality, but just as well as a shortcoming. I believe, however, that it relates to the somewhat ungraspable and ephemeral nature of true encounters. Aligning with this, the emphasis in the studio has always been on developing and deploying architectural artifacts more than on documenting them while encounters unfold.

The artifact in the midst of being explored here is titled Complicating Machine CoMa₀₁: Ont-Moetingsmeubel. As an artifact, CoMa₀₁ originated from a variety of efforts. First, it originated from a group of students' interpretation of the Dutch word *ontmoeten*, meaning to encounter or meet one another, an activity the participating students Sanne Delecluyse, Jens Lippens, and Ellen Fievez found to be fundamental in relation to their own practice of interior architecture for an urban environment. Moreover, they found it to be a most significant act happening between bodies (human as well as artifacts and matter) that are embedded in the socio-spatial constellations of the city. That basic idea became a topic of intense conversation among the studio's twenty students and my colleague Karel Deckers and myself, all

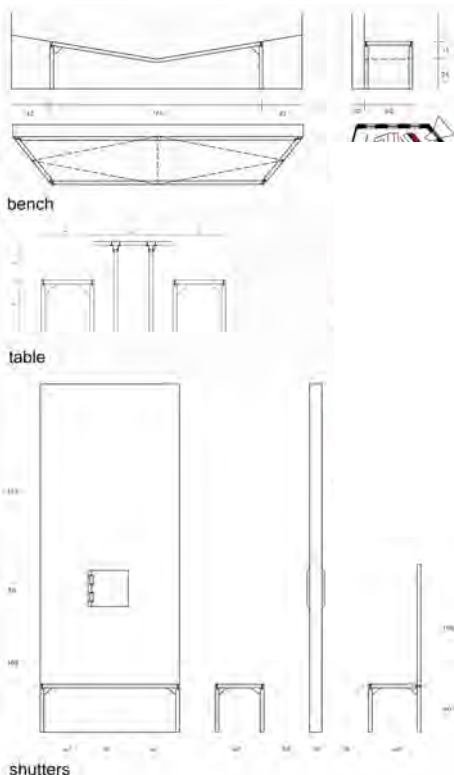
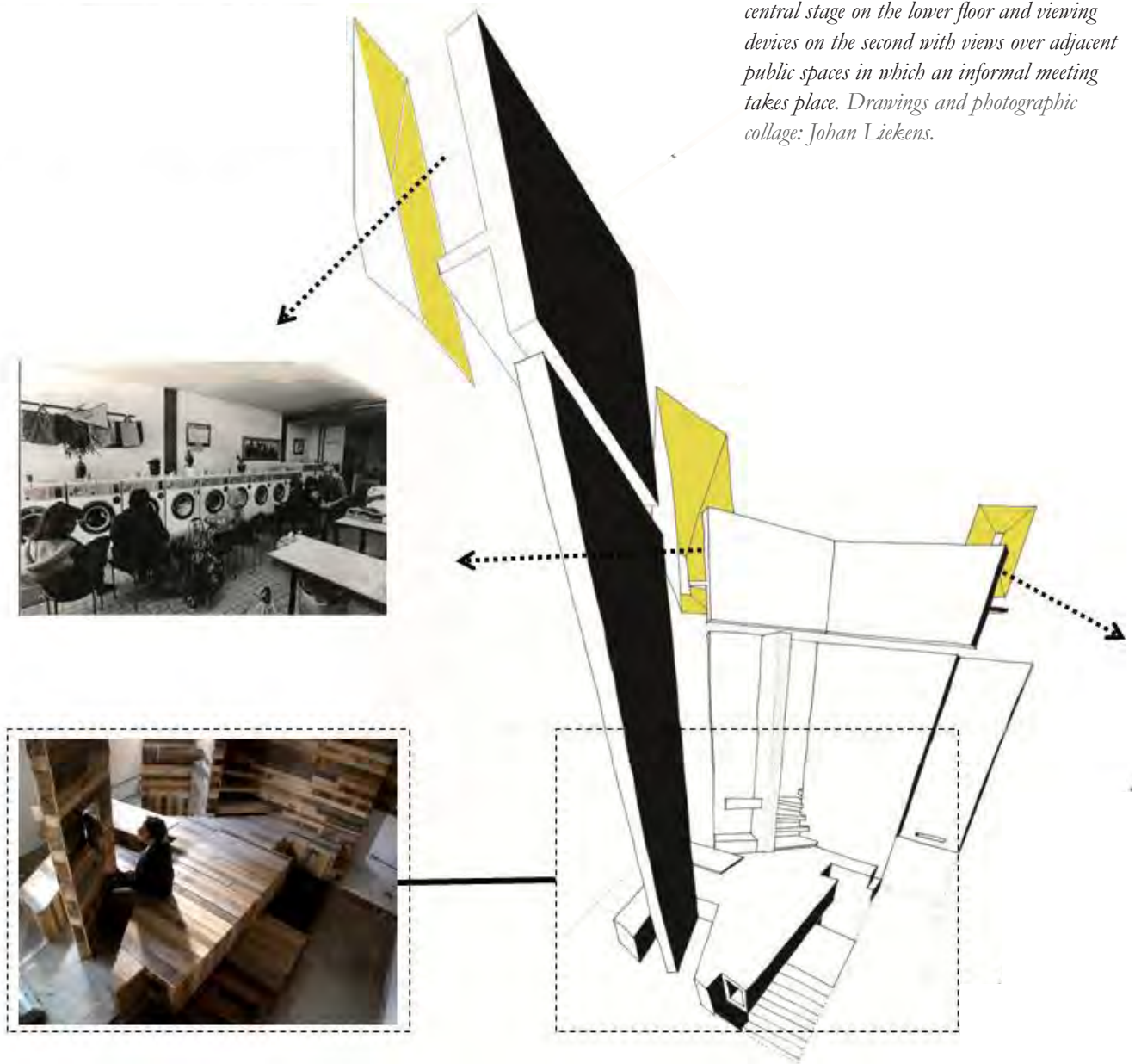

Figure 1.3: CoMa₀₁'s details. Drawings: Sanne Delecluyse, Ellen Fievez, Jens Lippens.



Figure 1.4: CoMa₀₁ Ont-Moetingsmeubel, Sanne Delecluyse, Ellen Fievez, Jens Lippens, Johan Liekens, Karel Deckers and students CoMa 2009-2010. Photographic collage: Johan Liekens.

Figure 1.5: Diagram of $CoMa_{01}$, with a central stage on the lower floor and viewing devices on the second with views over adjacent public spaces in which an informal meeting takes place. Drawings and photographic collage: Johan Liekens.



operating together as a kind of research group. In these conversations and following a multitude of observations of the urban environment, the notion of *ontmoeten* was gradually rendered more complex.

The theme was also approached from the perspective of the verb *ont-moeten*, where the added hyphen gives it the sense of *not being obliged anymore*. Hence the Ont-moetingsmeubel (furniture for no longer being obliged to meet but for to meet) started mediating between the intriguing but neglected issue of people meeting one another in public space on the one hand and the hidden, compelling, and possibly oppressive nature of how this meeting is staged on the other. Such staging expresses the will and authorship of the designer rather than the desires, intentions, sensations, and appropriations of those meeting and encountering one another in the urban environment. As an artifact, $CoMa_{01}$ thus mediated between formal, staged space and informal space as the carrier of people's everyday meetings. It mediated between the roles of benevolent furniture and frictional furniture. In its lower part, the artifact assumed the agency of distributing its visiting bodies in unfamiliar and sometimes discomfoting positions and

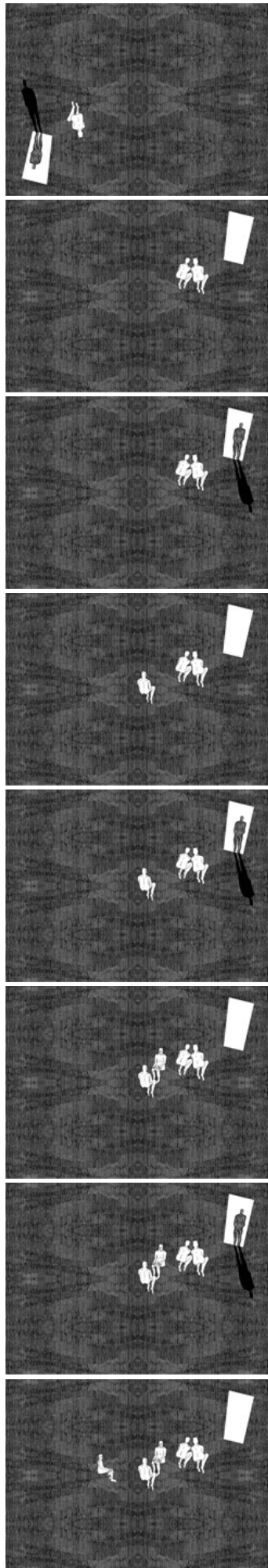

pairings, thereby raising wonder. At the same time, in its upper part, large viewing devices cut out vistas from the urban environment in which less formalized and more everyday meetings could take place. All of the positions afforded by the machine / interior deviated slightly from normal experience and ergonomics. A bench was inclined so that people steadily slid toward each other. Where people sat at a table, normal distances were slightly shortened so they would sense—uncannily—the knees of the one sitting across from them. A wall with mirroring shutters left the decision for communication, seclusion, or narcissism to the two users manipulating them. Hence, functionality was somewhat disrupted and an estrangement, even a certain pathos, overcame the experiencing body.

I was touched by the artifact's functioning, but at the same time somewhat dissatisfied with the scarce documenting of and reporting on the encounters that unfolded there. It proved to be difficult to clearly grasp and communicate the specificity of the poetic yet disturbing sensation that distinguished the Ontmoetingsmeubel during its peculiar functioning. As a consequence, I started to draw retrospectively the positions taken by and offered to the bodies that encountered it. Within the restricted timeframe afforded to the studio, following an initial period of observing urban phenomena in which the interior played a role, most of the effort had been invested in devising and constructing the complicating machine. My re-drawing of the encounter then came not so much as a way of illustrating but as a way of recapturing some sensations I and others had within the encounter, which had also surfaced in conversations. This re-drawing activity recurred as a methodological tactic in relation to some of the other artifacts I developed in my research. In the introductory chapter, I linked this methodological tactic to an *architecturally-framed, auto-ethnographic inquiry* and a *thick description*. I include some of these drawings here (Fig. 1.6-8) to thicken the description of the encounters and experiences generated.

Figure 1.6-8: Drawing CoMa₀₁, omitting the architectural hardware and foregrounding instead CoMa₀₁'s distributive agency and the odd and estranging nearness and pairing of bodies. Drawings: Johan Liekens.

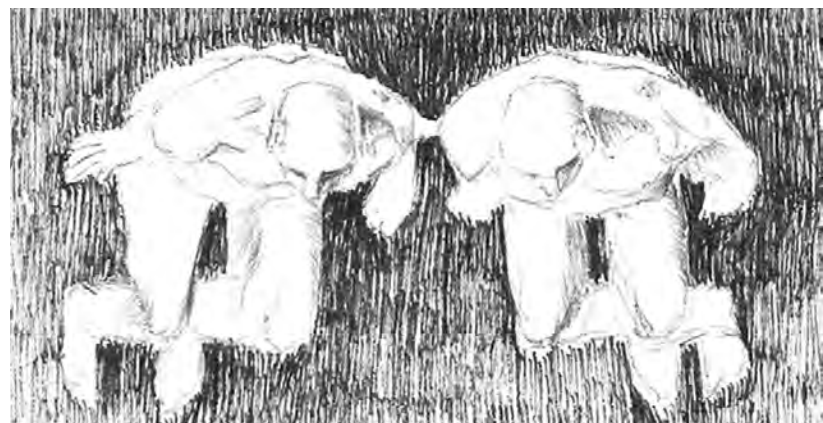

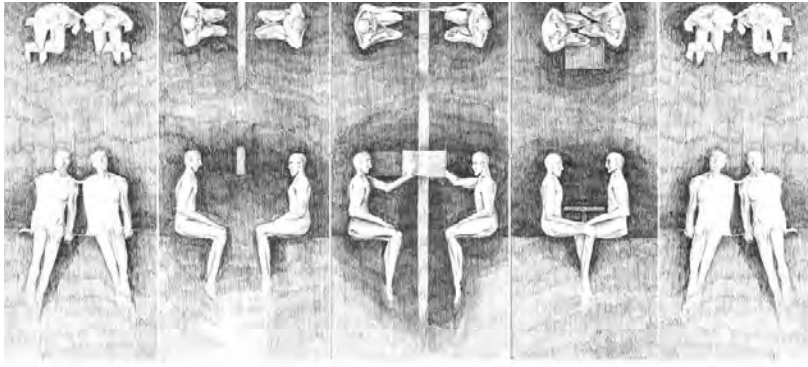

Without much initial thought, I made drawings of the situation—the lived experience—omitting the representation of the architectural hardware. As a consequence, this foregrounded without bias the constellation of positions of bodies. In studying the drawings, it seemed to me that a mute tension haunted them, similarly to the sensations the research group and those encountering CoMa₀₁ had experienced during its short life. The experience, in my understanding, is akin to a passage in Rossi's *Scientific Autobiography*, in which the architect finds himself confronted with an estrangement of his own body—an uneasy experience in which one's own body foregrounds as a quasi-mechanical entity (Rossi 1984, pp. 11–12). In Rossi's terms, such a sensation is one of “pathos.” This estrangement is deployed strategically here, akin to an observation made by Deleuze, who once identified the starting point of thinking as a grasping “in a range of affective tones: wonder, love, hatred, suffering. In whichever tone, its primary characteristic is that it can only be sensed” (Deleuze 1994, p. 139). Deleuze distinguishes this kind of sensing from acts of recognition. The sensation of pathos radiating from CoMa₀₁ can be considered such a grasping in affective tones, triggered by a form of bodily estrangement and constituting as such a starting point for thinking.

Looking from a broader perspective, CoMa₀₁ was also the first in a series of constructed artifacts that emerged from an initial desire and a subsequent effort to reorient my teaching practice in the design studios of the Master of Interior Architecture program at the KU Leuven Faculty of Architecture, Campus Sint-Lucas. The importance of CoMa₀₁ to this thesis cannot be overstated. As a protagonist, it substantiates and directs the other kind of architectural education / studio I was aiming to set up (as a method in the design program and also in this thesis). I will come back to this immediately. As a protagonist artifact, CoMa₀₁ also constitutes the initial explorative vector for launching and orienting my research project. In parallel, the design and construction of some architectural artifacts were initiated in the architecture firm where I am a partner, and these were now perceived through a similar lens—a lens that attributes to artifacts a poetic capacity, instigating one to think.

Since 2010 I have led a series of studios called Explicit in order to concretize the desire to establish an approach to interior(-architectural) design education that offers an alternative to the dominant design program at that moment (affirmative design). I will foreground the main characteristics of these studios

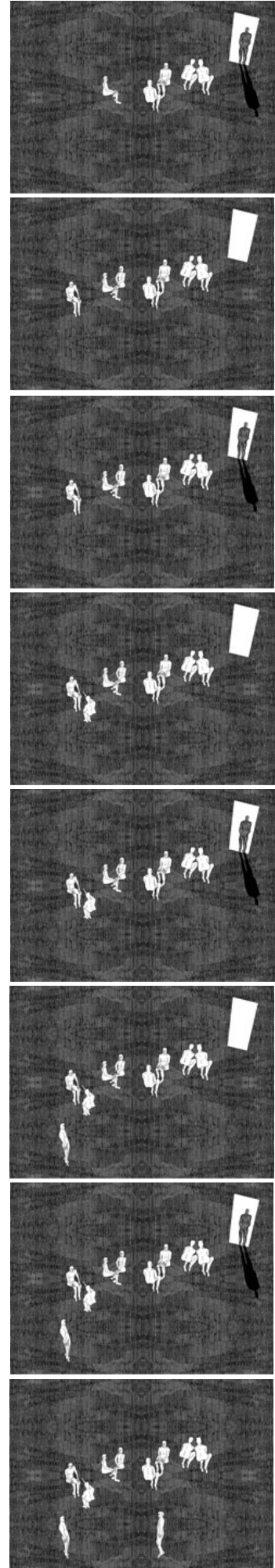

throughout this chapter. Together these characteristics can be seen as assembling a specific methodological approach pertaining to the overall *research-through-practice* approach I chose to deploy. Within the overall structure of the Explicit studios, I developed one called Complicating Machines / Complicating Interiors (CoMa/CoIn). Its emergence, as stated, relates to a certain dissatisfaction with some of the thinking recurrently dominating the realm of interior architecture and its education. These ideas are persistent and impede upon the designing activity of the interior architects in training, as I have witnessed throughout my teaching career. Accustomed to working on a reality that it assumes can be known through abstracted and scaled representations, the education of (interior) architects is in danger of withdrawing itself and its students from a direct and bodily engagement with reality—reality as it is, out there, ready and waiting to be seized. In CoMa/CoIn, students engage in constructing the urban environment through the interior, or through aspects and perspectives related to the interior. Becoming active in the urban environment in a direct way, they face reality in its real and full complexity. They engage with urban wanderers, users, and occupants, interfering sometimes in adversarial ways through the projecting and practicing of deviant and contrasting viewpoints and desires. Through conversations and confrontations, students develop seemingly evident but complex themes they engage in as citizens and that also relate to their future profession and practice, such as the aforementioned theme of *ont-moeten*. The students devise and deploy speculative artifacts that locally probe the socio-spatial constellations of the urban environment. This way of working and the nature of the artifacts produced here could be said to be close to the logics of an encounter. In acting in the urban environment, one unavoidably connects to fragments of the social, the cultural, the political, and the ethical, which together make up the socio-spatial construct that is the city.

As I was seeking an opposition to some of the persistent logic that biases interior architecture education and lingering on an adequate titling of the studio, philosopher John Rajchman's distinction between two radically different kinds of logic came to mind. He sees these logics as linked to divergent ways of creating. As an opposition to the Turing Machine, developed by Alan Turing as a predecessor to computers, Rajchman advances the concept of what he calls a "complicating machine." While a Turing Machine assumes logics of calculation and calculability, a complicating machine works through "problematizations." It moves "between usual distinctions, surprising us, attaining an irreducible disparity, an incalculable chance" (Rajchman 2000, p. 51). Bringing the idea of the complicating machine to the field of architectural design, it can be interpreted as introducing a form of *critical* design—a problematizing kind of design that calls things as they are into crisis rather than just affirming them.

I believe this type of design can be particularly relevant when conceiving design as an activity mediating the relationship between unstable, complex categories. In a paper co-authored with Janssens, I considered first the seemingly uncomplicated

categories of flower and vase. Between these, we stressed,

...design's relevance is considered to be a subservient, instrumental one, filling in the functional gaps with prostheses: between the flower and its water, we must design the vase. Hence, we think about the vase and design countless variations of it, considering the categories of the flower and the water as known and fixed and leaving them unquestioned. Design—and its accompanying design attitude—then constitutes an “affirmative” act(ing). (Liekens & Janssens 2011)

Within this logic, change comes as functional or aesthetic improvement. Considering the extent of architecture's relevance and potential performance, one needs to move beyond such change. We suggested that:

to make matter, to take an ethical stance on relevance, we must move beyond variations in the vase. We must not affirm but question the categories between which we design. Looking from a broad perspective, we believe that the main categories at stake in design are people (mankind) and world (environment). Unlike the water and the flower, people and world are unfixed, complex categories, both entangled in the many socio-spatial challenges we face. Hence, what needs to be problematized or questioned critically is how people and world relate to each other, a relation that is always established by some form of design. Our design act(ing)—and its accompanying design attitude—has to be “critical” if we want to instigate variations in thinking on meaningful relationships between people and world. “Making Design Matter” thus is to address our full capacities of acting within the socio-spatial constellations that relate people and world. (Liekens & Janssens 2011)

The architectural artifacts of CoMa/CoIn as well as the design attitude bringing them into being are thus from the outset conceived as critical. They call things into crisis; they instigate reflection in those encountering; they spark processes of making sense. They do so through practice—through making projections by means of materialized projects.

A complicating machine thus steers away from the mantra of the “optimal” architectural object. In the realm of (industrial) product design, designer and researcher Marco Susani and others have promoted the “post-optimal object” (Susani 1992) and its aesthetics, identifying it as the territory where the true challenges for design now lie. According to Dunne, practicality and functionality have now become evident, and hence it is indeed the post-optimal object that can provide “new poetic dimensions” (Dunne 1999, p. 28). A parallel with the realm of architectural design is not farfetched.

In the context of the above, the notion of the critical surfaced as a key creative and productive force driving the design attitude. From this perspective, artifacts are related to thinking and transforming reality. Artifacts are not just the passive carriers of

thought but can be poetic instruments enabling thought to unfold and some degree of change to occur as a result. CoMa/CoIn, as stated, is as much about critical revelation as it is about projective transformation by deploying speculative design propositions. I will elaborate on the double capacity of both critical revelation and projective transformation later in this chapter. However, first I will focus on the critical capacity assumed in architectural artifacts and their deployment.

While studying the first complicating machine constructed, a close affinity with some of the artifacts produced within the realm of *critical design* as proposed by Anthony Dunne and Fiona Raby became apparent. Both functionality and aesthetics are used to encourage reflection. At the same time, the idea of the critical as calling things into crisis suggested affinities with *critical theory*, sharing with it an epistemological and ontological stance. In the next sections, a landscape on a critical capacity of architectural artifacts is substantiated, drawing from these realms of *critical design* and *critical theory*. In addition, some existing interpretations of what has been called *critical architecture* are considered. Subsequently, another constructed complicating machine will be discussed, introducing an account of the political capacities of architectural artifacts.

It should be noted that the critical here is explored primarily in realms of design. I am aware that in close vicinity, a vast landscape of critical art can be explored. However, this is beyond the scope of this thesis. A personal argument for such a delineation can be found in the scheme introduced earlier (Fig. 0.10), which shows a gradient that extends from an invitation to a provocation to a shock to thought. I associate critical art more with the pole of the shock to thought, whereas the area of exploration for architectural design I consider to be the provocation (and invitation) to thought. In defense of this assumption, I refer to Dunne and Raby, who refer to critical artifacts as “para-functional” artifacts, which remain “within the realms of utility.” Only from the firm shoulders of functionality as one knows and deploys it, an attempt is made “to go beyond conventional definitions of functionalism to include the poetic” (Dunne 1999, p. 44). Thus, there is no real rupture with the functional artifact (and the aesthetic object), which I consider to be still at the center of the realm of architectural design. Going one step further, Otto Von Busch, a designer and researcher in the field of alternative design strategies, identified critical design’s association with the realm of art even as a crux. He stated that, in the arts, if something has already been done there is no interest in repeating it. This, he claims, is not the case for most forms of design. Even critical architectural designs build upon repetition, thereby developing knowledge (Von Busch, 2009).

This chapter took off by advancing a lived encounter with CoMa₀₁, one of the complicating machines and interiors constructed within the span of my research. Other *critical* artifacts and the lived encounters unfolding through them have influenced my research and will as protagonists be interwoven into the landscape that is this chapter. The methodological choice of constructing my research alongside and via artifacts

rather demanded that I visit the realm of critical design first when exploring a critical capacity of artifacts. Here, and this is specifically true for Dunne's *Hertzian Tales*, affective encounters with artifacts also propel the narrative. A second reason for favoring critical design as a point of departure for my exploration is that it too can be considered an attempt to re-conceptualize the artifacts populating a particular design field. In the fields of both product design and architecture, artifacts are heavily biased by the idea of affirmative design, and as a consequence it is challenging to re-conceive them and restore their full potential. The creation of a *supplement* to mainstream product design by the proposition of a current of critical design can thus help to substantiate a *supplement* to usual conceptualizations of the architectural artifact.

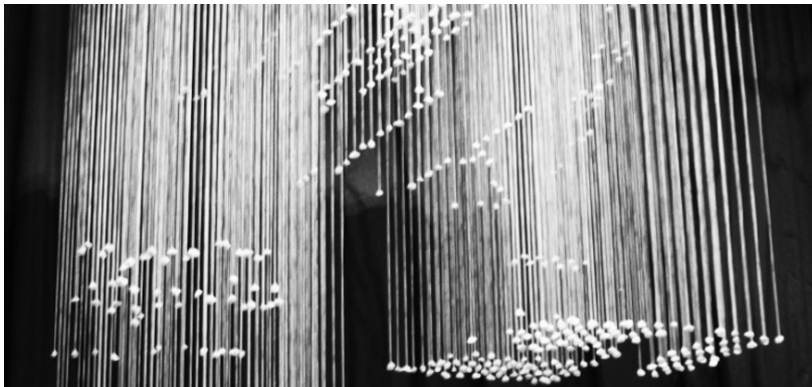

Figure 1.9-10: *Complicating Machine CoMa₀₃*, Jana De Mulder, Jana Haerinck, Jolien Van Der Eecken, Charlotte Van Maelsaeke and students of CoMa/CoIn 2012–13. Giving a taste of the variety of *Complicating Machines* that were developed over the years, this *Landscape of Memories* is laid out following the ingrained ritual gestures that once characterized a particular public space. Experiencing the construction, the discovering body is subtly forced into these gestures, thus reconstructing the memory of the space and the difference of its peculiar inhabitations. Photograph: CoMa/CoIn 2012–13.

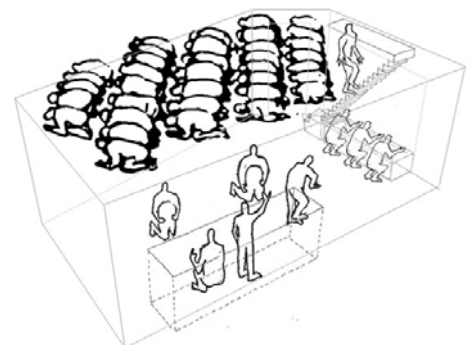
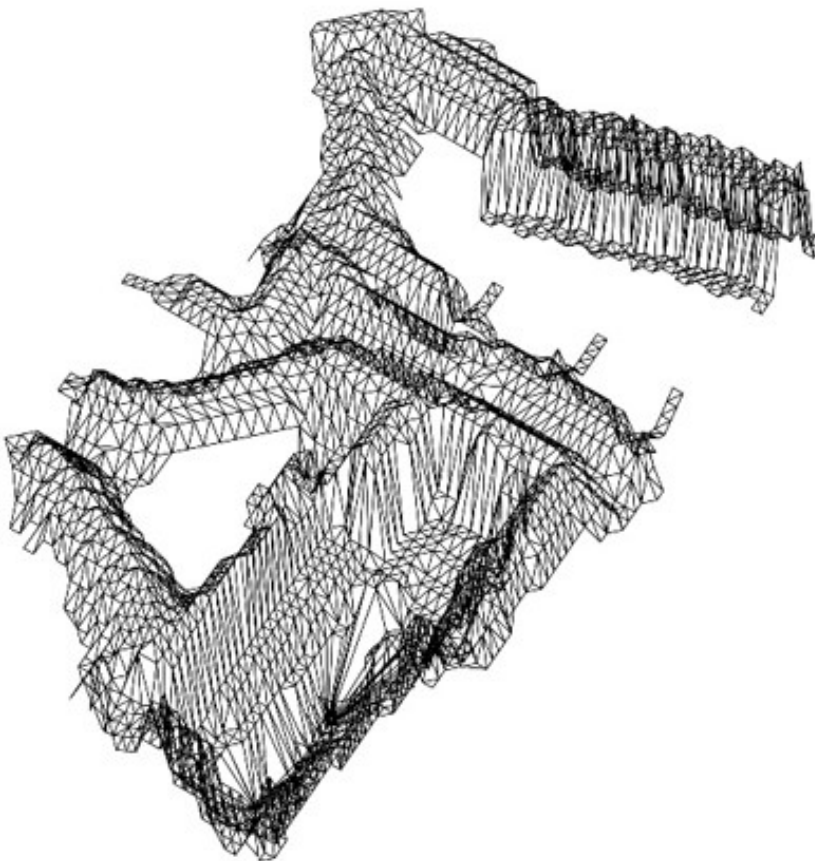

Figure 1.11: Former occupations of the small corner house, a miniature mosque as well as a workplace, corresponding postures with the landscapes proposed by the students. Drawing: Johan Liekens.

4.2. TRACING A CRITICAL CAPACITY OF ARTIFACTS IN CRITICAL DESIGN

4.2.1. – *para-functionality and aesthetics of use*

Exploring the realm of product design with the intention of distilling insights for conceptualizing architectural artifacts, one must be aware of some dangers. One such danger is that one draws here from a realm that is more heavily exposed to the logic of consumption. Within the field of product design, there are voices that, refusing to uncritically serve the logic of consumption, call for a new “object-ethology” (Susani 1992, p. 42). An ethology that “recovers and updates the interrupted discourse of material culture, in crisis since the world of objects was taken over by the world of products and the world of consumption.” What is at stake here is the ethical dimension of designed objects, and with it an awareness of the possibility of meaningfully contributing to the construction of reality through designing objects. While architecture is less subject to the spell of this logic of consumption, one could argue that it faces similar threats. One might think, for example, of those currents of critical architecture that claim architecture’s pure aesthetic autonomy. Ethics are reduced here to the kind of aesthetics that radically dissociate architecture from any wider, societal relevance. Or one might think of the types of architecture that are biased by functionality, which produce functional rather than existential space, using a distinction made by the architect and artist Wim Cuyvers. Hence the need in my research to explore an ethical capacity of architectural artifacts by designing, constructing, and deploying sets of them, and thereby contributing to what could be called an ethology of architectural artifacts. Dunne and Raby’s development of critical design can be considered a contribution to the recovery and update of an ethology of artifacts, too, and it is in that recovery I wish to situate my work here. Of primary importance is a shared suspicion of the dominance of affirmative design in practice, education, and to some degree in design research. Of course this type of design is much needed, but all too often it is considered the more relevant and thus better type of design, surmounting the speculative or critical types of design. However, in comparison to the latter types, it does not aid in questioning and conceptualizing and has more of an application character. Affirmative design and its accompanying design attitude have been identified by Rick Robinson as a narrow view of the interactivity between people and designed artifacts. Robinson writes that they miss the point “that the artefacts people interact with have enormous impact on how we think”—they “do not merely occupy a slot in that process” but “fundamentally shape the dynamic itself” (Robinson 1994, pp. 77–79). People’s dealings with artifacts give shape to their perceptions of reality, to their worldviews. The aspiration in this thesis, however, is not to create optimal but post-optimal artifacts—artifacts that renounce the dominance of the criterion of functional clarity. A good product is no longer a product that does not confuse or disappoint, that does not call for any reflection or interpretation. It follows that, in

supplementing mere affirmative logic, designers may strategically add some degree of noise to the interface between artifacts and people. Instead of realizing the perfect fit, the challenge for the designer is in the potential of preparing “gaps” for those encountering his or her artifacts to make sense of. Such gaps put in tension the values carried by and transmitted through artifacts with the values projected onto them in use.

Besides the above revolt against functional clarity, my research also pursues another sense of aesthetics. Relating to the notion of use, Dunne mentions an “aesthetics of use” (Dunne 1999, p. 42). Such an aesthetics refers to the raising of wonder, the provocation of critical reflection, the negotiation of sense—all of these brought about in an ongoing dynamic of use. Closely related to this, Dunne states that objects and artifacts are usually understood rather than interpreted, and against this he positions his design approach. One needs to be suspicious of notions such as user-friendliness and the like and question whether they are even consistent with the idea of aesthetic experience. Dunne suggests that “an alternative model of interactivity” is needed when thinking about aesthetic experience (Dunne 1999, p. 32). In this chapter, alternative perspectives on the artifact’s aesthetics will more than once take the stage.

Counteracting the logics of affirmation, I refer once more to our proposition of “a critical questioning design attitude inducing the dynamics of negotiation” (Liekens & Janssens 2011). Both the theme of the conference for which it was written, Making Design Matter, and the specific title of our contribution, “Matter Matters,” avow more generally to a material culture and ethology of artifacts that surmounts mere affirmative logic. Matter is not a matter of proper translation only. Matter really matters—it engages with, impacts on, and produces sense within the socio-spatial constellations of reality. In our contribution, we conceived of an indivisible twin pair *matter*, manifesting itself as a folded entity. In a first interpretation, to make matter is a call for an ethical stance on relevance, inspiring designers to make their designs count. However, architectural design is often valued by an audience of connoisseurs, isolated from the real world in magazines, exhibitions, and other distancing environments. This problematic also affects the critical designs collected by Dunne and Raby. Furthermore, as mentioned earlier, design’s relevance is often considered to be subservient and instrumental, filling functional gaps with prostheses. In a second interpretation, the other of the twins appears. Making design matter here is about design as a material manifestation to be encountered in the world, about making people think. Janssens and I suggested that it is necessary to draw materiality as a constituting term into the equation of instigating thought. Relevance and materiality fold into a unity by which the architectural artifact mediates the relationship between people and world.

I have always thought in my research in terms of a *slight* re-conceptualization of the artifact and a *slight* reorientation of design attitudes. I have done this intentionally: I deliberately advocate for a *supplement* to mainstream architectural design. I adhere to the idea that a critical capacity makes use of the more usual aesthetics and functioning of architectural artifacts.

Affirmative design and critical design are not polar opposites. Otto Von Busch, a critical designer himself, proposes in this respect a “revisiting” of affirmative design in order to unleash its inherent critical dimension (Von Busch 2009). I will come back to this. That said, I believe the critical is a much needed but neglected capacity of the architectural artifact that needs to be practiced in order for matter to matter to and impact on reality.

Condensing the above, at the outset of my research I produced a drawing that in a way captures what has been discussed above. It shows an architectural artifact that mediates the relationship between people and multiple worlds. An inspiration for that drawing was an encounter with John Soane’s intriguing drawing room, which in my interpretation operates as an architectural mechanism or lens for unfolding vistas onto formerly hidden and undiscovered (aspects of) worlds.

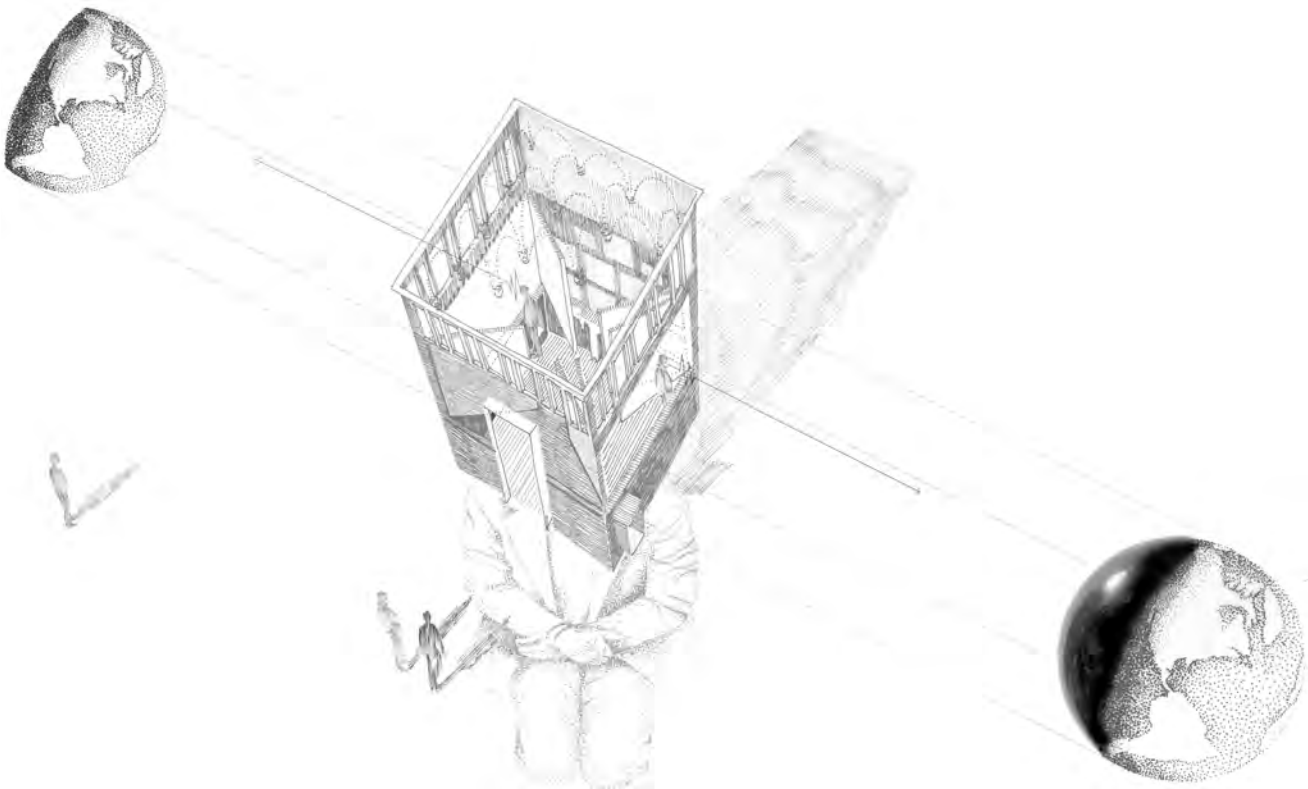

Figure 1.12: *People - Architectural artifact - World(s)*. Drawing: Johan Liekens.

Familiar to a resistance to mere affirmative logics, Rajchman has opposed what he calls logics of recognition. According to Rajchman, such logics weigh on each and every creative field, and with it on each and every creative act. However, Rajchman attributes to creative fields such as architectural design, the arts, design, urbanism, new technologies, and politics an important role in organizing resistance. These practices should, according to Rajchman, all deploy “interceders,” which he sees as necessary “to open up new paths or sketch new lines in our lives” (Rajchman 2000, p. 84). I consider the architectural artifact here to be such an interceder.

In parallel, Rajchman pleads for deploying a certain “vagueness,” not to be seen as a “deficiency to be corrected” but as a “reserve or resource of other possibilities.” Such vagueness allows to still “enter into complications with others.” It constitutes an openness toward possible futures (Rajchman 2000, p. 84).

Rajchman’s reasoning resonates here with some of the intents

of critical design. One can easily connect Rajchman's vagueness to critical design's opposition to the credo of optimal objects and that of transparent interfaces. In architecture, the notion of vagueness might be connected to the notion of ambiguity. For example, I consider Cuyvers's idea of "corrections" performed on official programs, as introduced in the introductory chapter, to be a strategy that introduces such ambiguity from which new possibilities may sprout.

Thus, architectural design may benefit from opening the floor to some productive forms of vagueness, ambiguity, estrangement, and confusion. Dunne has introduced the related concept of "para-functional" objects. Such objects introduce a form of "functional estrangement" that allows the object to attain other goals in parallel to or throughout the fulfillment of its proper function. Function is used to "encourage reflection." Here one is still "within the realms of utility" but attempts "to go beyond conventional definitions of functionalism to include the poetic" (Dunne 1999, p. 44).

In *Hertzian Tales*, he exemplifies how "para-functional" objects work through the introduction of a form of "functional estrangement," and as such raise wonder and provoke critical reflection. One fine example is a 1910 drinking cane devised for an alcohol merchant who spent much of his time visiting the bars of his customers. The cane allowed its owner to keep his wits about him by taking advantage of its ability to make connections—between hand, bar, glass, and gutter—by discretely siphoning off the drinks offered in each bar so that its owner did not need to refuse the polite gesture of the bartender. A trigger in the cane's handle allowed the owner to release the drink into the gutter upon leaving.

I insert here another para-functional object, the Suicide Machine, because it expresses well the ethical spectrum that critical design is concerned with. While the drinking cane is an artifact relating to etiquette, Jack Kevorkian's suicide machine may be seen as much more confrontational. It shows how an artifact can embody complex ideas as well as criticism. Seeing the machine provokes one to project a scenario of use onto it, to engage critically with the values foregrounded by it. In the absence of a human to administer euthanasia, the moral act of terminating life is displaced to the machine—the artifact itself becomes the locus of social critique, forcing the viewer to make sense of it and take a stance.

Whether one talks about para-functional, post-optimal, interceding, or complicating artifacts, all of these contest the concept of clarity of function. Instead the functionality of the object is colonized, ventured from, used, or even abused to encourage critical reflection in the user. All these objects resist the idea of designing transparent interfaces between people and world. Cultural theorist, urbanist, and philosopher of aesthetics Paul Virilio has identified the quest for an ultimate transparency of interfaces as an imminent danger to society. It brings with it a "subtle enslavement" to the values and systems of thought embodied in objects and artifacts. Users are at risk of no longer creating values by means of active thinking but rather just assuming what is transmitted. According to Virilio,

Figure 1.13: Drinking cane from a 1910 mail-order catalogue. Photograph retrieved from *Hertzian Tales*.

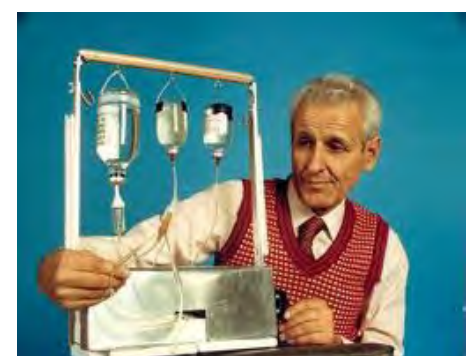

Figure 1.14: Jack Kevorkian's Suicide Machine. Photograph retrieved from <http://media.pressandguide.com/2014/07/07/remembering-dr-death-jack-kevorkian>.



Figure 1.15: Objets à Voir le Monde en Détail (Utilisation), Philippe Ramette. Photograph: Olivier Antoine.



“user-friendliness” merely serves as a strategy for making the unquestioned integration of values “digestible” (Virilio 1995, p. 135). The idea is that people have to be alienated enough to start thinking beyond the values and systems of thought offered to them, embodied in, and transmitted through the artifacts interact with. This *thinking-by-alienation* may have been experienced by those who encountered CoMa₀₁. They felt a certain productive (bodily) alienation, as has been shown earlier. In the case of encountering CoMa₀₁, the values called into question relate to the sharing of public space, via a reflection on *ontmoeten* and *ont-moeten*.

I insert here one more set of critical artifacts figuring in *Hertzian Tales*. Philippe Ramette’s *Objets à Voir* is in fact a series of prostheses that extend the human body but arguably also the human mind and with it human thought. The prostheses induce their users to see the world differently and think about their inscription as an individual in all the dimensions of the world. Their titles—*Objet à Voir le Chemin Parcouru*; *Objet à Voir le Monde en Détail*; *Point de Vue Individuel Portable*—are suggestive and an invitation to be made sense of. Well aware of the lightness of thinking they provoke, I adopt them here because they suggest a capacity inherent in critical designs making users see (and think about) the world differently.

I wish to shortly return to Von Busch’s promotion of a *revisiting* of affirmative design, notwithstanding the fact that he is classed as a critical designer. He conceives of affirmative design as having an inherent critical dimension. In other words, there is no critical design without affirmative design. Likewise, as has been suggested, there is no para-functional object without a functional one. In constructing his argument, Von Busch’s point of departure is the idea of the good craftsman. Von Busch argues that for good craftsmanship a critical eye is imperative, for it “finds weaknesses, contradictions and problems” and “speculates on what can be done to improve the design.” It is “experimental in its proposals and it affirms new possibilities with a voice of hope.” It enables affirmative design to become better. According to Von Busch, affirmative design revisited in such ways “assembles, supports, encourages and builds alliances between visions.” It is “a contagious viral idea for others to use.” It “makes proposals, however humble, simple or modest.” It is “attentive to the small details, and acknowledges that you will not build something completely new, but improve or redesign the old.” It has “the ‘can-do’ mentality of the hacker, assembler and reflective craftsman.” Affirmative design then “walks the critical path with care and does not lose sight of its own special craft: that of proposing new speculative designs and scenarios for the future” (Von Busch 2009). I argue that the projects adopted in this thesis are a mixture of the affirmative and the critical in that sense. Whereas, in the idea of Von Busch, critical designs often show themselves as a “chair which cannot be sat in (questioning functionality), an ugly vase (questioning paradigms of taste) or just plain bad designs” (Von Busch 2009), I consider the designs adopted here

Figure 1.16-17: Objets à Voir, Philippe Ramette. Photographs: Marc Damage.

to have emerged from the kind good craftsmanship constitutes. Here the critical is unified with the affirmative, as is the notion of craftsmanship with the new speculative perspectives and ideas on the world—a craftsmanship that thus brings some degree of transformation and change within reach.

4.2.2. *_poeticizing distances and gaps*

Drawing from critical design, there is a world to be discovered not in designing fits between objects and ideas but in poeticizing the gaps between them. Lingering on the notion of the gap, one may think of the concept of the engram—the conceptual imprint of things people keep stored as a result of habit. Critical designs arguably deviate from these engrams by introducing to them some form of estrangement. In *Hertzian Tales*, at several occasions the strategy of “poeticizing a distance” is connected to the introduction of such forms of estrangement (Dunne 1999, p. 30). Philosopher, psychoanalyst, and culture critic Slavoj Žižek foregrounds a similar mechanism when he talks about the idea of “more for less.” He pleads for creators to leave gaps of all kinds to be bridged by those who use or experience their creations. In “truncating” a totality, he assumes “the very loss will generate additional meaning and create a kind of depth.” He adds that “the safest way to ruin a work is to complete it, to fill in the gaps” (Žižek 2011). It is clear that a less can come disguised as a more. If one disturbs the normal functionality of an object by introducing to it a form of estrangement, this can be considered a less too—a less functional object. Žižek intriguingly claims that, in fact, “only the experience of a less opens up the space for a more” (Žižek 2011). Preparing artifacts with gaps here has the effect of providing space for interpretation.

In the above discussion, the adding of degrees of estrangement, confusion, ambiguity, and noise were identified as promising strategies for the designer. I shift the focus now to the realm where designed artifacts are received. Indeed, critical design clearly covers both the design side (conception) and experience and occupation side (reception). While a form of estrangement is to be introduced by the designer, it is the user that will do the interpreting. Although taking into account the realms of architectural conception and reception simultaneously may seem evident, it is not. Design theorist Alain Findeli has shown that in architectural design and design research the emphasis is often on “internal affairs” and not so much on the impact on or performance in reality (Findeli 2010, p. 289). Design and design research need to attend more consciously to how architectural artifacts are received if they want to alter reality in relevant ways. Jonathan Hill, an architect and researcher in the field of architecture and visual theory, states there are two different “occupations” of architecture: “the activities of the architect” and “the actions of the user.” Both of them make architecture, “the former by design, the latter by inhabitation.” Hill states that the relationship between the two is anything but evident—that between them ambiguities circulate. It should be noted that Hill calls the reception phase the phase of “inhabitation,” adding that

such inhabitation is always “multiple” (Hill 1998, p. 140).

Findeli has held the idea of a conception and a reception phase in each design project against the concepts of some of the leading theorists of design research, such as Nigel Cross and his concept of “design intelligence” (Cross 2006). Findeli discerns a deficiency, stating that when Cross uses the term *design*, he refers to the phase of conception only. That approach, according to Findeli, is incomplete because it lacks attention to a “project’s output once it starts its life in the social world” (Findeli 2010, p. 289). This may to some degree call into question Schön’s idea of the “reflective practitioner” (Schön 2008), who dialogues with his or her designed artifacts as a mainly internal affair. The idea needs to be extended, to be infused with a concern and responsibility for those interacting with the design once it starts its social life. The occupant’s questions, interpretations, and negotiations of sense are essentially part of the object’s design.

Connecting back to the idea of design as the designing of interfaces between people and objects, between objects and ideas, and between people and world, Findeli has defined such interfaces as always mediating a “habitability.” The aspiration of design is “to improve or at least maintain the ‘habitability’ of the world in all its dimensions.” To Findeli, habitability here refers to “the interface and interactions between individual or collective ‘inhabitants’ of the world (i.e. all of us human beings) and the world in which people live (i.e. their natural and artificial environments, [...])” (Findeli 2010, p. 292). What Findeli is after is to bring to the fore what distinguishes designers from human ecologists, both of whom claim their field of knowledge to be the “relationships between people and their environment.” An important difference here is one Findeli labels as epistemological: whereas human ecologists assume a “descriptive and analytical stance,” with an emphasis on “understanding reality,”

Conversely, the aim of designers is to modify human-environment interactions and to transform them into preferred ones. Their stance is prescriptive and diagnostic. Indeed, design researchers, being also trained as designers—a fundamental prerequisite—are endowed with the intellectual culture of design; they not only look at what is going on in the world (descriptive stance), they look for what is going wrong in the world (diagnostic stance) in order, hopefully, to improve the situation. In other words, human ecologists consider the world as an object (of inquiry), whereas design researchers consider it as a project (of design). Their epistemological stance may thus be characterized as projective. (Findeli 2010, p. 293)

Each in their own way, the artifacts adopted and produced in *Architecture’s Poetic Instrumentality* reveal underexposed and latent aspects of reality (e.g. the sheer fact that different versions of reality exist) and attempt to somehow transform reality by projecting alternative versions (e.g. by making different versions of reality sensible). More than *prescriptive*, the stance of architects is *projective*, the former presupposing right and proper ways of doing things, the latter enabling an alternative future to take shape. What

is of primary importance here is that Findeli acknowledges the potential transformative impact of design altering socio-spatial reality.

I want to expand briefly on the notions of *the poetic* and *poeticizing* touched upon in previous sections— notions important enough to be included in the title of my research. When trying to bridge gaps or distances designed strategically into artifacts, a certain constructing activity, a poeticizing, is induced. The poetic here can be interpreted in two different but interrelated ways. First, there is the poetic opposing the functional. Second, there is the poetic as related to the notion of *poiesis*, referring to a form of making, constructing, and acting. Janssens shows that the poetic is linked not only to a making activity as such, but to an activity of “making-up” (Janssens 2012, p. 215). Drawing on the work of Kenneth White, Janssens considers this making-up activity to be a mode of composing with transformative power. Critical design provides the stage for a poetic interplay between people, matter, ideas, and values, enabling new ideas and values to come into being or be made. According to Dunne, a certain “sensitive skepticism” encourages such making of ideas and values, emphasizing that “values and ideas about life embodied in designed objects are not neutral, objective or fixed, but man-made, artificial and mutable.” The user is drawn into the equation and activated, pushed away from the generalized caricature of a user (Dunne 1999, p. 30). Design here is always ideological. Either it is complicit in transmitting established values without questions asked, or it sets up a transformation of values. In the latter case, the user is truly empowered, as is the artifact.

4.2.3. *tactile clue-ing*

As mentioned, user-friendliness makes the integration of values transmitted by artifacts digestible. Counteracting the strategy of user-friendliness typical of affirmative designs, it would be logical for critical designs to conceive and deploy strategies of “user-unfriendliness.” Dunne conceives such unfriendliness as “a form of gentle provocation” (Dunne 1999, p. 38). Drawing on John Sturrock, Dunne perceives a connection with the “poetic function of language,” giving a taste of conceiving strategies of user-unfriendliness in architecture. According to Sturrock, the poetic function of language has the effect of making readers aware of language itself. Language is so to speak “foregrounded.” Sturrock adds that in the everyday use of language, such opacity is unwanted. Everyday language is “instrumental” and “transparent.” In contrast, “with the poetic function comes a certain opacity, for the writer is no longer passing information [...]. There may also come an intentional ambiguity” (Sturrock 1986, pp. 109–10). By foregrounding the language of a creative practice, one no longer instrumentally passes on information but instead enables a certain poesis to take off within the communication.

I encountered a foregrounding of architectural language one day when visiting the reading room of the Ghent University Library. While sitting at one of the reading tables, I became bodily aware that something did not quite add up. A certain



Figure 1.18: Denkmal 9, Jan De Cock.
Photograph: Jan De Cock.

Figure 1.19: Scheme and Sketch of the Denkmal 9 at the Ghent University Library. Artist: Jan De Cock, sketch: Johan Liekens.

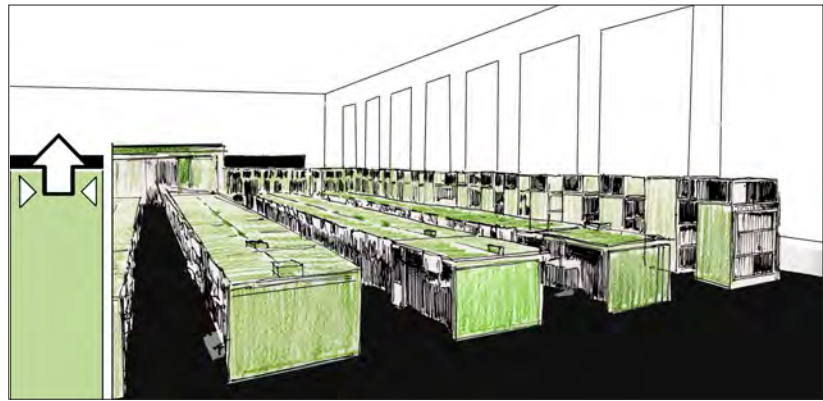
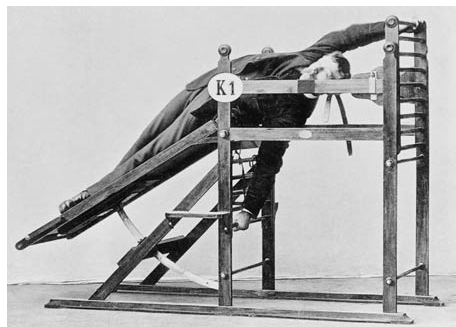
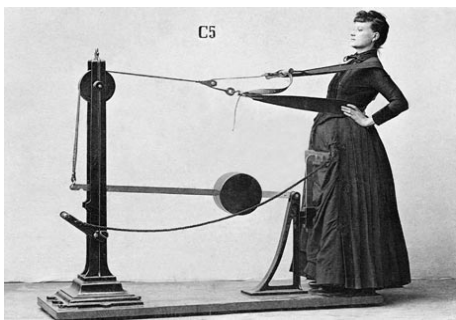
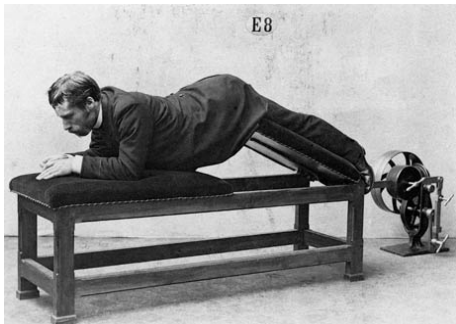

Figure 1.20-23: Patients and Machines, 1890s. Seeing and using these machines must have caused the viewer to imagine a tentative modeling of scenarios for use, to try to make sense of them. Photographs: National Museum of Science and Technology, Stockholm.



unease came over my reading body, causing me wonder not about the book in front of me but about the room I had found myself in. I sensed in my body a slight deviation from normal ergonomics, and with it a deviation from inhabited experience. All the reading desks as well as the other standardized furniture had been covered with a surface of greenish plywood. Though it was a rather minimalistic intervention, heightening the reading desks by only three centimeters, using them gave an uncanny awareness of the difference and at the same time caused me to wonder. I looked at the room and now noticed the stark opposition between the greenish base I was embedded in and the upper part of the room, which was shrouded in abstract white. I will not go into the intentions of the artist, Jan De Cock, who introduced to the reading room this greenish surface of his work *Denkmal 9* (De Cock 2004). What is important here is the powerful potential of leaving delicate tactile clues that establish a delicate form of estrangement, making one wonder. I argue that some of the artifacts adopted in Dunne's *Hertzian Tales* utilize a similar tactile clueing, and I consider the artifacts of my research as deploying this strategy as well.

In the above discussion, some aspects (concepts, strategies, mechanisms) of a critical capacity of designed artifacts were illuminated from the realm of critical design. To some degree they have been held as a mirror to the thinking, constructing, and deploying of the architectural artifacts I have developed. In the following sections, I will expand on notions of a critical capacity of architectural artifacts that have been developed more directly within the realm of architectural design.

4.3. TRACING A CRITICAL CAPACITY OF ARTIFACTS IN CRITICAL ARCHITECTURE

Having suggested throughout the above exploration of the realm of critical design that there are concepts, strategies, and mechanisms that are interchangeable with architectural design, I also suggest the idea of a common critical stance. The notions of the interceder and complicating machine found in philosophy (opposing mere logics of recognition that impede creation there) resonate with notions such as para-functionality and an aesthetics of use found in critical design (opposing logics of an unquestioned affirmative designing). It follows that all these concepts, strategies, and mechanisms feed the re-conceptualization of the architectural artifact I am after. If one acknowledges that there is a shared critical stance, this suggests that there is also a shared ancestry. I believe that ancestry can be situated in critical theory, the area of exploration of the next sections.

4.3.1. *a shared stance with critical theory*

The realm of critical theory is approached here from the point of view of an architect curious about ideas and concepts held in common about the critical capacity of artifacts. The exploration in that sense is not intended to be exhaustive.

The origins of critical (social) theory are often situated in the Frankfurt School. However, as the lecturer in education and research studies Michael Crotty has noted, criticism as a chosen role is not a modern phenomenon, but part of a substantial tradition reaching back to Socrates and before (Crotty 2003, p. 113). Whatever its origin, an agreement exists on what is the foundation of the specific critical attitude with which reality is surveyed. Political philosopher Raymond Geuss and others have identified *emancipation* and *enlightenment* to be principles and aims of this critical attitude. These principles are “making agents aware of hidden coercion, thereby freeing them from that coercion and putting them in a position to determine where their true interests lie” (Geuss 1981, p. 55). They empower. More than just seeking to understand reality, they challenge. Instead of accepting the status quo reality, they aim to spawn change (Crotty 2003, p. 113). Critical theory’s principles, its critical stance, open up paths of seeing reality anew. In critical design, Dunne has also attributed to these principles a founding role. There is an interesting difference, however. Whereas critical theory works through text, primarily enlightening and emancipating the reader of the criticism, critical design works through critical designs. Here those using and encountering designed artifacts are enlightened and emancipated. Similarly, Von Busch suggests that critical designs have a unique capacity to locate critical issues “within a context of domestic material culture,” close to everyday life and lives (Von Busch 2009). This is certainly true for architectural design, which substantially frames everyday life and lives.

The critical stance shared by critical theory and critical design also applies to the so-called “critical project” of architecture. One might think of the 2007 book *Critical Architecture* (Rendell et

al. 2007), which brought together a multitude of contemporary theorists and practitioners around the theme of the contemporary critical project within architecture. The book revealed a close relationship between characteristics of critical theory and what is considered critical architecture.

As suggested, the main attitude of critical theory in surveying social reality is its refusal of a deterministic stance that accepts the social world as it is and studies just that. Instead, the intention of critical theory is to unmask all kinds of essentialism expressed through ideologies and power structures that consciously and unconsciously govern everyday social reality. Critical theory's aim, then, is to break the status quo approach to social reality by formulating an alternative. Critical theory thus re-conceptualizes more traditional schools of theory. An epistemological shift is noticeable (shifting assumed ideas on knowledge and knowledge production) as is an ontological shift (shifting the ideas on being and existence, which I argue includes the understanding of artifacts). The kind of critical designing examined in previous sections can be similarly seen as shifting away from an epistemologically and ontologically more traditional affirmative design thinking. With regard to the principle of enlightenment, both critical theory and critical design challenge, through text or artifact, what people think to know and how they come to know. Both are rooted in the certainty that the existing state of affairs does not exhaust all possibilities, thus opening up paths for action. With regard to the principle of emancipation, both seek to emancipate their readers or users through text or artifact, making them rethink their being in the world. It should be noted that both consider the interaction between people and the (social) world as not just objects of inquiry but projects of design, where transformative action is key.

It is interesting to see how Hilde Heynen, a theorist in the field of critical (architectural) theory, considers the possible infiltration of the critical ancestry of critical theory into architecture. She notes that such infiltration "has led to the expectation that the most worthwhile architectures should [...] relate to their social condition in a critical manner." The question then is how they do this relating. Heynen suggests that architectural works accomplish this by establishing a "mimetic relation" with program, site, materials, and context. Architectural works take in aspects of their socio-spatial surroundings and give substance to them in specific ways. They critically reflect their surroundings, so to speak. This does not mean that the critical in architecture is about the "packaging aspects of architecture," which would be a "reduction," according to Heynen. Instead, the critical operates on various levels at the same time, the constant concern being the social interests at stake in any project of architecture. Thus, the critical in architecture, according to Heynen, should always position itself in relation to the following questions: "Who is building and for whom?" "What is its impact on the public domain?" and "Who will profit from this development?" It is these questions that architecture needs to address and mimetically incorporate if it wants to fulfill its critical aspirations (Heynen 2007, p. 49).

4.3.2. *_ a hint at the political, but a moralizing one*

In the development of a “critical artefact methodology”, Simon Bowen, a designer and researcher in the field of critical design, has characterized the engagement of critical theory with reality as political, because it seeks not only to reveal problems but also to make a fairer world (Bowen 2009, p. 108). The critical principles of enlightenment and emancipation thus affiliate with the notion of politics in that they aspire to bring change. The critical is “wedded to practice” (Crotty 2003, p. 130). Relatedly, Bowen suggests that there is a problem with the weight attributed to the notions of enlightening and emancipating, a risk of getting trapped in logics of mere moralizing. Similarly, Von Busch states that critical perspectives easily become “theory-heavy” and even “nihilist” because they recurrently lack agency “other than that of tearing down.” Critical approaches are at risk of retreating to a merely oppositional stance from which nothing new can emerge (Von Busch, 2009). The critical becomes associated with the negative and infertile. Similarly, sociologist and philosopher Bruno Latour states that critique has “run out of steam,” that it has been “put on repeat.” As a result, Latour calls for ways to rethink the methods by which one critiques, insisting on a new criticism that “assembles” rather than “deconstructs”—a criticism that moves away from “matters of fact” and closer to the urgent and contradictory “matters of concern” that everyone should be engaged with critically (Latour 2004b). Following the latter perspective, designing can become an activity that makes visible (as contradictory) these matters of concern. According to Von Busch, with critical designs one must add reality, not subtract it. One must “imagine a critique that is associated with ‘more reality,’ a multiplication of proposals, generating more ideas and assemble these in discussable scenarios, rather than debunking all as futile in an automatic critical response” (Von Busch, 2009).

Conceiving of the critical role architectural artifacts can play in their socio-spatial surroundings, I prefer to think of them in terms of bringing about *intensive* spaces characterized by difference and negotiation between different possible paths. Here one is enabled to determine where one’s true interests lie through acts of appropriation. Stranded values can be re-negotiated. Contradictory values can be played out.

4.3.3. *_ other critiques of critical theory*

Some other critiques of critical theory are adopted because of their relevance to the reasoning in my research. A first critique relates to the question how and where the critiques of critical theory are read or encountered. It is argued by many that critical theory’s critiques remain constrained within text and book, impeding their potential. They are accessible only to those who can find and read them. Critical artifacts suffer less from what could be called this action deficit. More precisely, a critical artifact deploys its critical capacity more directly, allowing it to be encountered and appropriated in tactile and bodily ways. This is attested to by Bowen, who claims that it is crucial that in order for artifacts to function as critiques, stakeholders must engage

with the “values, assumptions and ideas inherent in the critical artefacts” through direct or tactile means (Bowen 2009, p. 120).

As suggested previously, a similar critique is applicable to critical designs, however, appearing often isolated from reality in exclusionary environments. The *reader* of exhibitions and publications in which artifacts appear is often an informed reader. Hence, there is no truly wondering encounter with or substantiated by artifacts. Drawing on the philosopher, cultural critic and essayist Walter Benjamin, Hill has promoted architecture as something that is most often encountered in “a state of distraction” (Benjamin cited in Hill 1998, p. 144). There is a radical difference with “a state of contemplation” characterizing the aforementioned informed reader of exhibitions and publications. It should be noted that this state of distraction accords well also with the notion of the encounter. Hill remarks that “architects often choose to ignore this simple distinction” because of a “plethora of social and cultural codes” that consider the everyday as an inferior area of exploration. This puts architecture at risk of becoming the object of contemplation for connoisseurs too. In my research with the complicating machines and interiors as well as the artifacts stemming from professional practice, the everyday has been consciously made the center of exploration, enabling the possibility of encountering artifacts in a state of distraction, subsequently making one wonder.

A last critique of critical theory is added here. It is suggested by Van Toorn, stating that criticality always arrives at the scene of reality “preloaded with a prior theory that verifies something,” even if this something is yet to come (Van Toorn 2007, p. 20). Criticality risks addressing only that part of reality that is established and thus can be accessed for critical review. In this sense, criticality mainly looks backwards. It risks losing sight of certain parts of socio-spatial experience that are yet unarticulated. Theorist and critic Raymond Williams states that a dominant, established system approaching reality establishes in itself a “limitation or selection of the activities it covers.” This implies that it “cannot exhaust all social experience, which therefore always potentially contains space for alternative intentions which are not yet articulated as a social institution or even project” (Williams 1979, p. 252).

4.3.4. *_divergent notions of critical architecture*

Different and divergent interpretations of the critical circulate in the realm of architecture. Following architect and architectural educator George Baird’s conclusion that the majority of architectural criticism is written and therefore enacted in a medium different from that of its objects (Baird, 2006), I keep the focus in the following on the critical capacity of designed architectural artifacts and their deployment. That said, it is indispensable to consider some of the important discussions on critical architecture.

The structuring notions in the discussions on critical architecture are often *resistance* and *autonomy*. Different ideas on critical architecture exist because these notions are otherwise perceived. Questions on autonomy in architecture

can be brought back to considering architecture's connectedness with and engagement in reality, even if this comes as a radical disconnection. While modernist architecture could be considered a critical project about social reality, intending to transform it for the better, more contemporary interpretations seem to progressively dilute their critical potential. The debate is played out mainly in the opposition of critical practices and so-called "post-critical" or "projective" practices, a term advanced by Robert Somol and Sarah Whiting. Some of the architectural practices calling themselves critical engage in mere formal resistance to what they consider the corrupted mass culture of consumption, resulting in an architecture with a purist aesthetic autonomy that formally breaks away from the mess in which social reality appears. Politics becomes replaced by mere pragmatic actions (Van Toorn 2006, p. 55). Ethics becomes reduced to aesthetics in the narrow sense of the word. "Architecture wants to be architecture and nothing else" (Van Toorn 2006, p. 55). According to architectural and urban critic Kim Dovey, critique here has become "formal," leading "to the exclusion of social practice." The assumption such critical architecture makes following Dovey is that resistance against "the dominant order" of society is possible by means of a "very own order of materials, surfaces and forms" (Dovey 2007, pp. 252–53). Other critical architectures establish a similar retreat from the social world and play intellectualized architectural games to be savored by connoisseurs. The criticality operating here is "embodied in" and at the same time "protected by the difficulty of the work" (Dovey 2007, pp. 252–53). With regard to both forms of critical architecture, some have spoken of an "illusion" of criticality—a "talismanic" criticality that comes as a "charm" that preemptively avoids possible questions on relevance (Macarthur & Stead 2006).

What binds all these critical architectures together is that they situate their criticality in a radical aesthetic autonomy and an absolute and purist resistance to either influencing society or being influenced by it. Heynen asserts that such architectures miss an essential characteristic of what she says constitutes critical architecture—that is, the typical characteristic of assessing facts exactly on the basis of their relation to social reality. Heynen identifies these so-called critical architectures as "free-floating, utterly disconnected and completely intellectualized discourses and practices" (Heynen 2007, p. 50).

4.3.5. *_ towards a critical, political and ethical projective-ness of architectural artifacts*

Post-critical practices and projective architectural practices consciously seek divergence from the aforementioned cultures of both critical architecture and critical theory. They contest the view of criticality as the application of critical theory in the field of architecture, because they discern some deficits, which were foregrounded earlier. Sarah Whiting and Robert Somol, architects and architectural theorists, have as protagonists of the post-critical project outlined its position. They propose a shift from the dominant paradigm that anchors criticality in the notion of

autonomy and instead promote a projective attitude that relies on architecture's instrumentality, performativity, pragmatics, and so on. A shift involving "the effects and exchanges of architecture's inherent multiplicities: material, program, writing, atmosphere, form, technologies, economics, etc." (Somol & Whiting 2002). More precisely, they discern a move from the three features defining "hot" critical architecture ("critique, representation and signification") to the three features defining "cool" architectural practice ("projection, performativity and pragmatics") (Somol & Whiting 2002, p. 74). What they suggest to architecture is that it "projects forward alternative (not necessarily oppositional) arrangements or scenarios that intend to change something" instead of "looking back or criticizing the status quo" (Somol & Whiting 2002, p. 75). Criticism and what it means to be critical are at risk of becoming obsolete, dead weight, and especially no fun. What is drained with it is architecture's political dimension, a point that is also made by George Baird (Baird 2007).

Rendering the post-critical or projective project of architecture even more a-political, contemporary projective practices seem to adhere to heterogeneity as such. Architect and architectural historian Reinhold Martin characterizes their production as an "affect-driven, non-oppositional, non-resistant, non-dissent form of architectural production," not taking into consideration the future(s) at stake (Martin 2007, p. 150). What substantiates is "permissive heterogeneities" (Van Toorn 2006, p. 57)—heterogeneities that avoid each form of conflict, however crucial to the political capacity. As Van Toorn warns, such heterogeneities in the end produce nothing but new forms of consensus, whereas a re-composing activity exactly offers the possibility to "raise certain urgent matters without consensus" (Van Toorn 2006, p. 58). Architecture critic Michael Speaks makes mention of a re-composing activity of data and not of values (Speaks 2007, p. 14). These data are translated only formally, technically, or organizationally into architecture. In the re-composing activity no *direction* is imposed by its designer. There is no "political mediation" whatsoever, only "a kind of degree zero of the political" in which there is no place for "dreaming of a new world" (Van Toorn 2006, pp. 56–57). No longer dreaming of alternative futures, architecture is reduced to a stage of pragmatic actions. It has either become a neutral background on which data of reality are projected or a material body of which the objective parameters are overstretched. In my research, aligning with Van Toorn, the architectural artifact is considered a hybrid that has "objective qualities" but which simultaneously is "imparted by meaning, by use and perception, by touch, by looking at and being looked at, by habit and tactile appropriation, by a coincidental discovery during a walk or conversation" (Van Toorn 2007, p. 29).

In the above discussion, I have occasionally associated the critical with the negative; in contrast, the political becomes associated with the positive. In a similar movement by which architecture's projective nature becomes passive, the notions of both the political and the critical are also at risk here of being silenced. Kwinter has suggested that architecture assumes "a vantage point from which all action is understood as political in the positive (i.e., not critical) sense." Politics are "nothing more

than the production of new possibilities” (Kwinter 2002, pp. 11–12). As stated before, such an approach is dangerous. It prevents the critical and political capacity of architectural artifacts to reach their full potential. The critical vitally and political vitally need one another. Hence, the political is not served by association with a just-do-it attitude or an anything-goes mentality. Conversely, Dovey emphasizes that architecture needs to point out directions, that it needs to enable and constrain, thereby assuming responsibility (Dovey 2007, p. 254).

While I think highly here of notions such as instrumentality, performativity, and pragmatics, as will become apparent, I see these as inseparable from making an impact on and transforming reality. Therefore, they are wedded to architecture’s projective, critical, political, and ethical capacity. Architecture can join these seemingly irreconcilable notions. And some of these notions need to be redefined and pushed away from oversimplified interpretations. Besides my interpretation of the critical, political, and ethical capacity of architectural artifacts, I also develop an alternative interpretation of what it means for architecture to be projective and, additionally, what it means for architecture to be *pragmatic*. Constructing a different interpretation of what can be pragmatic architecture, seeing it as a way of reintroducing to architecture the ethical, will be one adventure embarked on in Chapter 2.

Thus, one challenge for architectural practice lies in defining what it means to work in projective and political ways upon reality. Is it merely an approach to venturing through projects that forges new possibilities, or does it add such an interpretation that one works through projects on the wider project of and for the world? It is of course this latter interpretation I intend to contribute to. The projective and political project is a project ultimately suited for the realm of architecture. Indeed, as Dovey states, “in order to be classed as ‘architecture’ there must be some vision for the future of the built environment at stake” (Dovey 2007, p. 258).

The notion of consensus described above as a quasi-evident mechanism and aim is to be counteracted to some degree within architectural creation. Once more I argue that this is a story of a necessary *and*, not *or*. One should balance consensus-oriented mechanisms and aims with the productive potential of “dissensus” as elaborated by Jacques Rancière (e.g. Rancière 2010, 2011). One should indeed, as mentioned before, profit from the productive potential of introducing degrees of estrangement, confusion, ambiguity, and noise to architectural creation. One should incorporate the productive forces of disagreement and conflict, because such forces allow conflicting voices to take the stage and enter processes of negotiation and therefore sense-making. The aforementioned idea of the designer taking the responsibility for pointing out a direction in itself constitutes a glimmer of such disagreement, because that initial position is immediately offered itself for negotiation and contestation.

Alongside this notion of dissensus, of productive disagreement and conflict, the second part of this chapter now further develops a political capacity assumed in architectural artifacts and their deployment.



★_5.

EXPLORING A POLITICAL CAPACITY OF ARCHITECTURAL ARTIFACTS

My work on this chapter began with an encounter with one of the artifacts constructed in the educational context of the CoMa/CoIn design studio. The studio launched an exploration of a critical capacity assumed in architectural artifacts and their deployment, connecting to the realms of critical design, critical theory, and different kinds of critical architecture. Because of certain deficits discerned in relation to the critical, the orientation of this chapter started shifting toward a more action-oriented political capacity of architectural artifacts that enables them to project (alternative futures) through a project, suggesting in this process the productive potential of forms of disagreement and conflict, which in turn call for processes of negotiating and hence sense-making. A second complicating machine, CoMa₀₂, is introduced now as a protagonist for initiating a further exploration of that political capacity.

Before introducing CoMa₀₂, some general traits and aims of the CoMa/CoIn studio are briefly revisited in order to picture the general contours of the studio as an educational setting. These contours will be more extensively elaborated after I have introduced CoMa₀₂. Assembling all the traits and contours of the studio that will be revealed will give substance to the slight re-conceptualization of the architectural artifact that I was aiming for.

The CoMa/CoIn studio is offered at the end of the bachelor's degree program just before the start of the master's program (i.e. between undergraduate and graduate phases). It is a time for increasing focus on the research dimension of (interior-) architectural design. CoMa/CoIn can be seen as answering broader calls to make the research dimension more explicit. Thinking about how to answer that call, I have always conceived of the architectural artifact itself as a mode and instrument of inquiry, working in concert with its aesthetics and functionality. It has been my aspiration to raise awareness among the students of this intriguing capacity inherent in architectural artifacts. In order to raise such awareness, CoMa/CoIn is based on the idea of realizing encounters with (or rather through) artifacts. The preferred way of working is at 1:1 scale, interceding in real urban contexts. There are evident reasons for assuming such a posture that link craftsmanship in interior architecture with aspects of material making and articulating. The idea here is that the one reinforces the other. But more compelling arguments have led to this posture. I have already sympathized with the logics of encountering as the starting point of (critical) reflection. I have already pointed out the importance attributed to processes of negotiating sense that play out between real people embedded in the real socio-spatial constellations that constitute urban reality. Working at full scale in the urban environment, the complicating machines and interiors affect their users and passers-by in immediate ways. Moreover, the students also leave the safe confines of the school to become active in the lived city, at the full scale of life. The genre of materialization is real, embodying



materiality, and not the representational materiality of drawings and scale models. According to Brady Burroughs, an architect and researcher in the field of design education, becoming an architect through architectural education all too often implies that one is enculturated in “a ‘correct’ way of doing things,” a proper way of doing architecture. That is a “professional” and “serious” way that itself is “rarely questioned or even noticed, as a habit from a certain time and place” (Burroughs 2016, p. 52). In this light, CoMa/CoIn can be seen as an attempt to break with habitual enculturation. It is more uncertain, certainly, but also more playful, sharp, and above all far more compromising, allowing students to get their hands dirty by engaging with messy reality.

I consider CoMa/CoIn’s artifacts to be the kind of projective practices as identified in the latter part of the preceding sections. They problematize, revealing hidden or latent aspects of reality, and they project alternatives (alternative possibilities, alternative realities) through a project. They aim, using philosopher and cultural critic Adrian Parr’s words, “to unsettle and to transform our understanding of certain problems” (Parr 2005, p. 53). They make wonder, preparing the stages and constraints for wonder to occur, and people in turn make sense of the wonder they raise within them when encountering them.

Thus, CoMa/CoIn’s artifacts are the kind of conflictual and complicating heterogeneities proposed before. It should be noted that a first heterogeneity present in the set-up of CoMa/CoIn is the enigmatic conjunction of the urban (environment) and the interior itself. The CoMa/CoIn studio is about the interior seizing the city, instigating through its manifestation and productive combination processes of critical reflection and political negotiation—a negotiation of alternative possibilities and realities. CoMa/CoIn in general is about the student exploring ways to contribute to the socio-spatial construct of the city by being a citizen. But more specifically, it is about the student exploring ways to contribute to that construct through his or her specific role as an engaged interior designer.

Thus, CoMa/CoIn must be seen as invoking within the student a self-initiated interior architectural research practice on the socio-spatial phenomenon that is the city. The student does not wait for prescribed programs to be imposed upon him or her, but instead approaches urban reality through real-life explorations and observations. The students are constantly searching. The point of entry into the urban environment and its prevailing discourses, practices, and habits is intuition and curiosity. Setting up within the educational context, such self-initiated research practice aims at empowering the student to move beyond the posture of an architectural practitioner as a docile service provider. It also intends to produce refreshing thoughts on inhabiting the urban environment as a socio-spatial constellation. In this light, CoMa/CoIn is also an effort to slightly re-conceptualize the architectural artifact in the student’s mind, conceiving it anew as a potent explorative instrument. The heterogeneous conjunction [urban+interior] can be seen as the primer of each of the past, present, and future articulations of CoMa/CoIn. In this second part of the chapter, I will come back to this conjunction amply,



Figure 1.24-28: Horizontal discussions in the CoMa/CoIn studio, involving discussions between citizens, students, and teachers, all on-site. Photographs: CoMa/CoIn₀₁ studio.



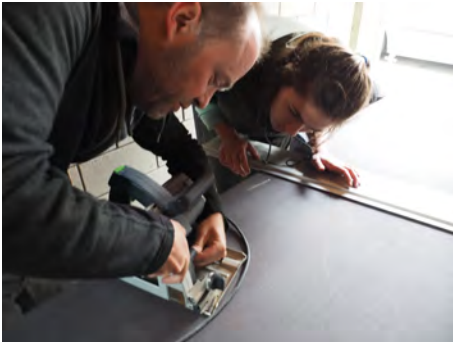

Figure 1.29: Horizontal making in the CoMa/CoIn studio between teachers and students. Photograph: CoMa/CoIn₀₆ studio.

even using it as a structuring notion around which the traits and contours of the studio are set.

It should be noted that CoMa/CoIn is set up with a horizontal research structure: thinking and acting are shared among all participants. They all share the same challenge. There is none of the dominance of a teacher-student relationship, but instead an intensive and shared effort of working on the urban environment with the interior as an instrument of inquiry, of discussing the urban environment with ordinary citizens.

Next I will describe an encounter with the complicating machine CoMa₀₂.

___5.1. AN ENCOUNTER WITH c0mA₀₂

CoMa₀₂ was constructed as a complicating interior in 2010. It can be seen as aiming to disrupt the continuum of enacting urban routines that have become ritualized and taken for granted. CoMa₀₂ was titled (Con)Fusion by Cooking. Its concept arose from combining observations made through explorative walks undertaken by CoMa/CoIn's students in the city. One set of observations gathered by the students Liselotte Delobelle, Siska D'Hondt, and Maxine Morel related to the fact that the part of the city where CoMa₀₂ would be constructed functioned as a vibrant neighborhood with passionate participation in public life. It was a neighborhood colored by food and food culture(s), in which food takes an important place in many acts and rituals. However, they found that these rituals often remained within the enclosure of each (food) culture, preventing them from making an appearance in public space. The students also observed a sprawl of institutionalized initiatives to use food as a way of fusing people into the idea of a harmonious community. They witnessed the harmonious sharing of food around standardized tables under the sterile light inside isolated community centers. Here every friction and difference was meticulously avoided. What CoMa₀₂ essentially does is to reveal and lay out the situation encountered as fundamentally more complex and divided. To this unproblematic and unquestioned fusion the research group wanted to contribute some degree of disagreement or confusion into this urban routine.



Figure 1.30: Small corner house in the city of Ghent from which the students deploy their interior design interventions in and on the city. Photograph: Johan Liekens.

Figure 1.31-32: CoMa₀₂ Con-Fusion by Cooking, Liselotte Delobelle, Siska D'Hondt, Maxine Morel, Johan Liekens and students CoMa /CoIn 2010. Photographic collage: Johan Liekens.



With regard to the idea of revelation by means of architecture, I want to draw close to architectural phenomenologist David Leatherbarrow's observation that architecture can show and disclose aspects of the world that are hidden (Leatherbarrow 2001, p. 88). Nilsson has pointed out that architecture is able to make "hidden relations" between things visible, to construct relations between aspects and elements through certain artifacts (Nilsson 2014, p. 91).

CoMa₀₂ is built into an existing small corner building, which has housed a variety of semi-public occupations (fig. 1.11). At one time, the small building functioned as a mosque, at another as a workplace for the neighboring harbor. CoMa₀₂ comprises two floors. The lower floor consists of a cooking place. A closer look reveals that there are actually several cooking places. Different and possibly irreconcilable meals can be prepared simultaneously. The cooking place is not private but collective and claimable. All doors of the building are removed, disclosing the interior to the adjacent public space. Above the cooking places, a giant sculptural exhaust hood is constructed—a hood that is segmented because of the existing beams supporting the floor above, its tubes conducting the sensation of fused or split odors and fumes to the people sitting at the table on the upper floor. These tubes become the structuring figure of the table that characterizes the upper floor. However, the table deviates from what is normally recognized as a table. Or rather, it is constructed from both recognizable elements and deviant ones. The table is too large in different senses. Normal conversation and belonging are disrupted. Moreover, the table gathers its users in odd and unpredictable pairings. The upper floor has three gradually heightening levels, allowing or forcing the people at the table to choose between three different and culturally connoted postures. Combining this with ideas of different physical and mental forms of community in the rituals of eating, the table mirrors the cultural composition and working of the neighborhood itself as a heterogeneous juxtaposition. From the surface of the table, dishes are scooped out and the whole surface is varnished with an acid-resistant varnish, making the surface itself usable as one common dish. However, some of these circularly enclosed dishes are interconnected by means of scooped-out gutters. The gutters do not coincide with the



Figure 1.33: Fusing people into one harmonious community, resulting in an in tune sharing of food. Photograph: CoMa/ CoIn₀₂ studio.

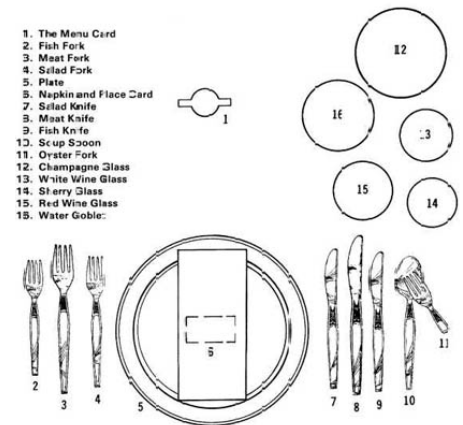

Figure 1.34: How to lay out a formal dining table, complete with oyster fork and sherry glass. Drawing retrieved from: <https://www.gentlemansgazette.com/dinner-etiquette-formal-dining/>

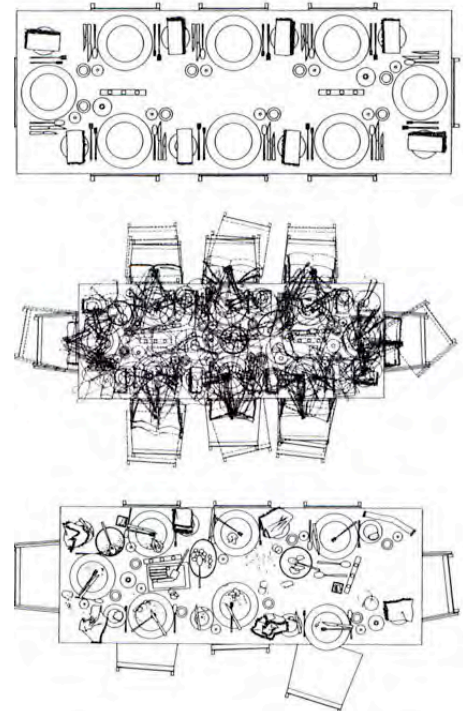
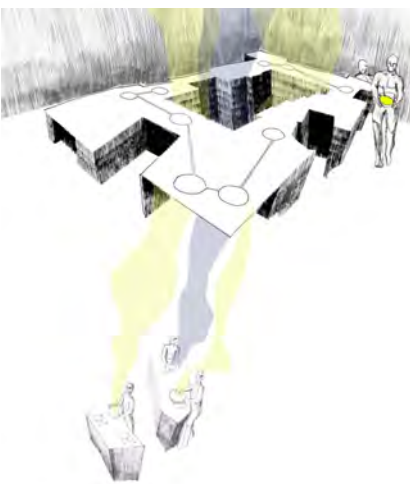
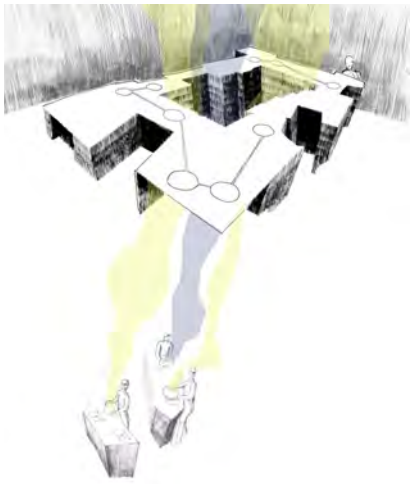
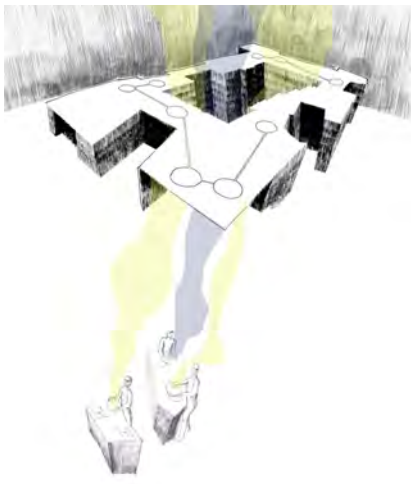

Figure 1.35: Increasing Disorder in a Dining Table, illuminating the activities happening in the flat expanse of the table that gradually disrupt its order. Drawings: Sarah Wigglesworth and Jeremy Till.





expected pairings afforded by the table, but instead disrupt these. There might be an agreement on the sharing of food, but juices might start to run from unwanted directions. One may come to find oneself in strange company.

The instances of *however* in the above discussion introduce to the table degrees of noise, friction, difference, and even some degree of user-unfriendliness, to recapture a concept illuminated by e.g. Dunne in previous sections. They can be seen as part of the unrecognized parties at the table striving for recognition. All of these notions are normally considered uninvited guests at the table, but in design processes they became valuable dynamics through use and in combination with recognized dynamics. In my understanding, these constitute a main generative dynamic: that of politics. The political dynamic here is rooted in the possibility and potential of disagreement, in dissident voices joining in and the subsequent processes of negotiating sense. What might happen is open, not known or wanted in advance.

In CoMa₀₂ one can distinguish similarities with artifacts produced by other explorative and investigative architectural practices. I discovered these similarities after construction.

*Figure 1.36: Complicating Machine
CoMa₀₂ Con-Fusion by Cooking,
setting CoMa₀₂'s table, cooking places in
the lower part and the unusual pairings
of users at the community table in the
upper part, odors and juices flowing in
unpredictable and (un)wanted directions.
Drawings: Johan Liekens.*

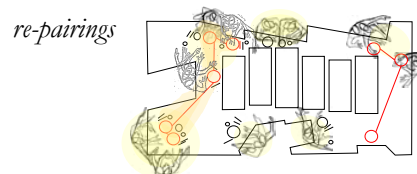
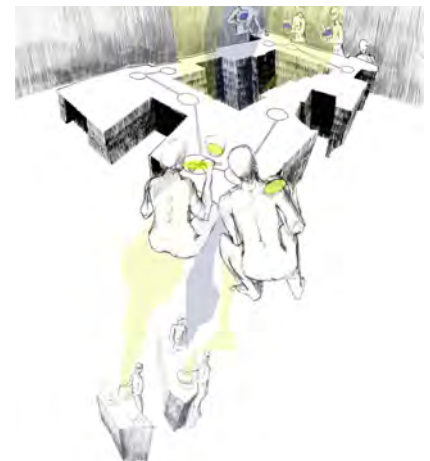
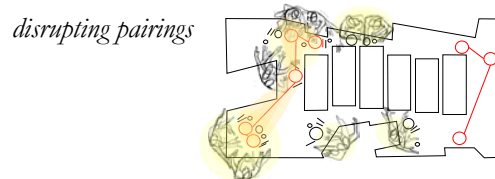
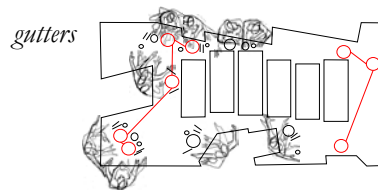
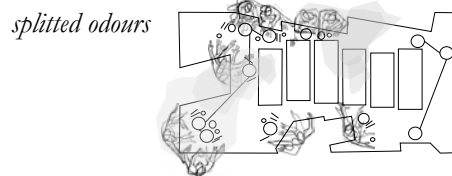
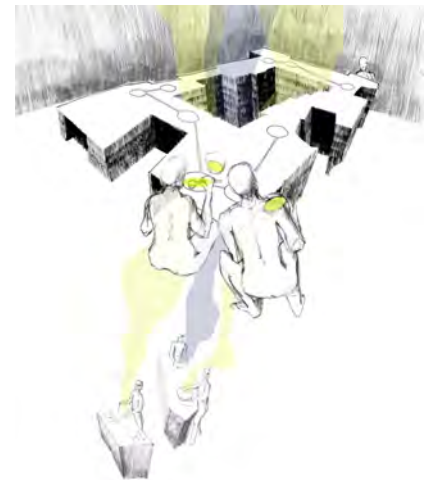
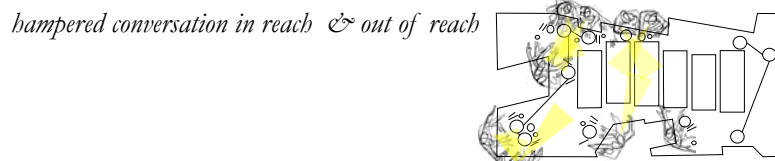
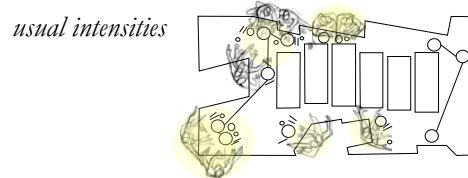
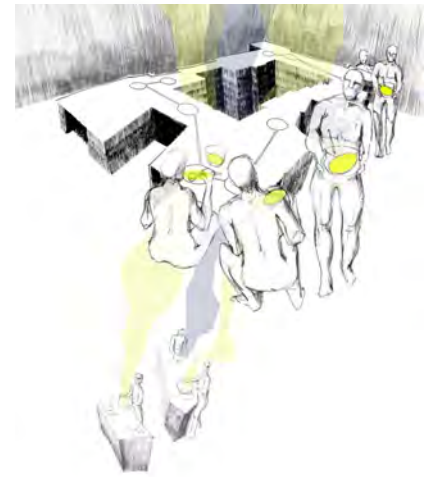
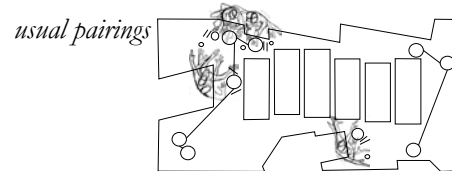
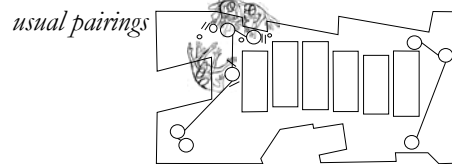
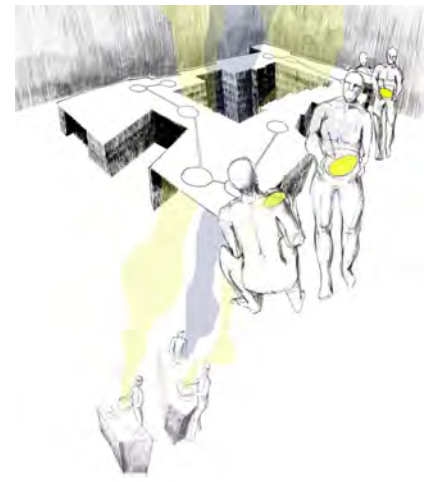
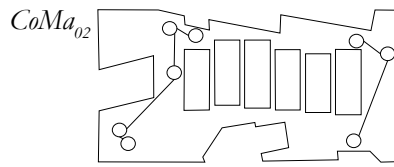
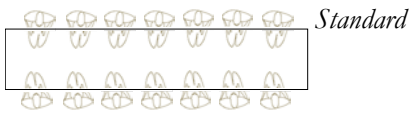



Figure 1.37: Aerial view of Wexler Studio's Community Table, part of the work *Two Too Large Tables*. Screenshot retrieved from Google Maps.

I will highlight two such practices because they further the idea of CoMa₀₂ as a design that encompasses friction, conflict, and disagreement as generative constituents. There is a formal resemblance with the work *Community Table*, one part of Wexler Studio's *Two Too Large Tables* in Hudson River Park, New York. In a first, formal interpretation, Wexler Studio's *Community Table* is also too large in terms of the usual ergonomic standards for what constitutes a good table. As is the case in CoMa₀₂, its plane stretches over a distance that hampers normal communication across the table. Furthermore, the orientation of its seating positions is also deviant and disturbing. It is interesting to follow the interpretation of author Donald Goddard, who identifies Wexler Studio's table as too large not only with regard to the sheer physical dimensionality; he says it also offers "too many possibilities for interaction and non-interaction, and it is impossible to reconcile so many possibilities, except that they all take place at the same flat, horizontal expanse of the table" (Goddard 2001). It is clear that what he calls "too many possibilities" not only refers to the functional possibilities of the table, but also to a multitude of interpretations, appropriations, and occupations through which one makes sense of the situation encountered.

Hence, the table gathers its users in unusual pairings. One can try to sit in community, as a form of agreed upon belonging. One can opt to turn one's back to that same community, preferring isolation. Other parallel communities might take shape. One may even have no choice whatsoever when some of the available seating positions are already strategically taken. CoMa₀₂ affords or provokes multiple possibilities (both A and non-A) and brings these different possibilities into negotiation. The sensation of an unusual situation here is akin to what one may sense looking at the paintings of out-of-place torsos distributed over a table surface by the painter Michaël Borremans or reading the thoughts of architect and theorist of critical spatial practice Jane Rendell, who testifies that:



Figure 1.38: *Four Fairies*, 2003, showing an out-of-place distribution of torsos on a surface (Dutch: tafereel), generating an estrangement similar to that of CoMa₀₂. Painting: Michael Borremans.

Placing things and bodies in unusual combinations positions us in a new uncharted territory. Lost in space, our cognitive mapping devices destabilized, we imagine a new poetics of space and time. We understand anew the world we occupy, the relations between dreams and realities, between mental life and social relations, between objects and subjects. This space-time is unlimited, it is not stagnant with the inscriptions of specific and expected responses. [...] The accidental and continually shifting juxtaposition of apparently unconnected things produces a density of interpretation. The layering of different daily patterns of understanding and using invoke architectural time as transient. There is no moment of completion; rather you are aware every day of the continually widening cracks, the disintegration of the building fabric, the shifting spaces and roles of the furniture contained within them. Links are made between real objects, real and imagined objects, and real and imagined subjects—dreams are lived, lives are dreamt. (Rendell 1998, p. 245)

The design activity in CoMa₀₂ is not primarily oriented to solving or eradicating the ambiguities and ambivalences raised by the productive difference between conflicting possibilities. On the contrary, there is a preference to remain within this momentum of ambiguity and ambivalence, within this momentum of suspension, within this “density of interpretation” in which the evident is constantly broken up again. Suspension here refers both to *suspending* as a postponement and to *suspense* as a passionate raising of tension. Recapturing Goddard’s observation of an irreconcilability of possibilities at Wexler’s *Community Table*, what he misses is a crucial potential also present in CoMa₀₂. Before any statement can be made about irreconcilability, a time exists in which the different possibilities appear in parallel, a time in which they connect and affect one another within the same horizontal expanse of the table. It is this time of tension and suspension that establishes the table’s generative working—by adding unfamiliar possibilities to possibilities to forge new possibilities, by adding unfamiliar experiences to experiences to forge new experiences, and by adding unfamiliar interpretations to interpretations to forge new interpretations. As such, the table’s functioning can be seen in relation to the production of knowledge.

There is another resemblance with Wexler Studio’s work *Coffee Seeks Its Own Level*, which is inspired by the natural science principle that water seeks its own level. The work uses basic scientific principles learned in high school as a means to explore architectural issues. It can be seen as choreographing group dynamics. If one person alone lifts his or her cup, coffee overflows into the other three cups with all of its playful and probably irritating consequences. All four people need to coordinate their actions and lift simultaneously if they want to keep things functional. They have to negotiate and agree, but they can choose to disagree, and that disagreement becoming present through use. A powerful image of consensus is revealed, paired with its opposite: a playful and irritating dissensus. It is the tension between the two that constitutes the work. The scooped-out plates interconnected by means of scooped-out gutters choreograph group dynamics in similar ways. In the table, instances of consensus are fused with instances of confusion and dissensus. However, the choreography in CoMa₀₂ arguably surpasses the game-like and playful choreography of *Coffee Seeks Its Own Level* in the sense that it is coupled to a real form of public togetherness. It is only through use that the tension is revealed, contrasting with Wexler’s work in which what could happen is already announced prior to use. Wexler’s work, then, is arguably less one in which something new and unexpected might emerge from the exploration. In CoMa₀, the possible travelling and intermingling of food substances across the community table perhaps attains a sharper, more political effect that proceeds through productive disagreement.

CoMa₀₂ proposes a table that consciously aims at a production by deviating from the image or engram everyone holds of the table—what everyone recognizes as a good table. As such, it cuts through logics of recognition, impeding people’s thinking and acting in the world. It is to be noted that the engram of the table



Figure 1.39: *Coffee Seeks its Own Level*, Wexler Studio. Photograph: Wexler Studio.

has been used by certain authors who wanted to move thought beyond dull logics of mere recognition. Kwinter, for example, has proposed that architecture should “let us wonder if our thinking and acting rather than deriving from the banality of everyday acts of recognition (‘this is a table,’ ‘this is a chair’), should not seek its models among stranger and more compromising adventures” (Kwinter 2002, p. 44).

CoMa₀₂ is an experimental and experimenting model constructed in everyday urban reality. It is a stage on which a negotiation-driven and therefore political dynamics plays out. It sets the table and invites the feast of difference to commence. I described the constraints set by the table in the discussion above. I’ll leave the interpretations of whatever could happen at this table to the imagination of the reader. I have added drawings of some scenarios I witnessed or imagined happening. With CoMa₀₂ in mind, I will now further elaborate on the traits and aspirations of the CoMa/CoIn design studio. I will do so by contracting entities of thought around the idea of the enigmatic conjunction [urban+interior], to which I have already referred.

5.2. cOMa/cOiN: A PRACTICE WITHIN THE ENIGMATIC CONJUNCTION [URBAN + INTERIOR]

CoMa/CoIn, an investigative architectural practice (and method) embedded in an educational context, explores the urban environment through an inscription of the interior within it. The interior is seen as having a relevant and specific capacity to meaningfully inscribe in the urban context; conversely, the urban environment is seen as having a capacity for admitting meaningful inscriptions. [urban+interior] thus constitutes a fertile breeding ground for experiment. The interior becomes an instrument that grafts onto the urban socio-spatial tissue not merely as a way of adding but also as a way of undoing and re-doing. Rendell has suggested that processes of undoing (and re-doing) “reintroduce the city to the urban dweller and occupant, offering an opportunity to discover something new, and through their own agendas and perspectives find a new mapping and a new way of thinking about cities. The strange becomes the familiar and the familiar the strange” (Rendell 1998, p. 231). In CoMa/CoIn, the experimenting activity in the conjunction is seen as both critically un-doing and politically re-doing. CoMa/CoIn thus substantiates alterations in the urban environment at local points apt for such alteration. The alteration is more than physical: discourses, habits, and existing relations become altered with it. CoMa/CoIn intends to make see, conceive, and experience anew the way people inhabit the urban environment.

5.2.1. *[urban+interior]: the porous relationship between urban and interior*

In order to better grasp the enigmatic nature of the conjunction [urban+interior], it is helpful to bring to mind some intriguing

cartographies that infuse the urban environment with the interior (environment). They give a taste of what tensions are raised in the conjunction. It should be noted that such cartographies were also used to introduce the CoMa/CoIn studio to its future participants.

One cartography, Gianbattista Nolli's 1748 copper plate engravings of Rome, shows a figure-ground representation of the built and open urban space of Rome. Intriguingly, the idea of public space retrieved in other cartographies of that time becomes literally extended to include all kinds of public interiors. These interiors are conceived of as *open* civic spaces—interiors one might be drawn into when exploring the city. The *poché* technique used by Nolli suggests the presence of a degree of permeability—something between the dark and the white, between the occupied and that which still awaits occupation. It is this in-between space affording and awaiting occupation that CoMa/CoIn aims to seize. The permeability here is seen as not only spatial; in my understanding, it is also applicable to urban concepts, rituals, discourses, habits, and so on.



Figure 1.40: Rome Engravings, in which a *poché* technique is used, heightening the suggestion of the permeability of the urban fabric ready to be seized. Drawing: Gianbattista Nolli.



Another cartography joins in. Lars Von Trier's movie *Dogville* is similar in some ways to Nolli's cartography, though operating through a different technique. In this cartography, every instance of architecture as an intermediary between interior and urban is reduced to the neutral flatness of a white chalk line. And yet, one continuously ponders that demarcation between interior and urban because of their immediate and quasi-unmediated coexistence. The point of view shifts with the position of the camera. The story is framed either from an observing and seemingly neutral top view or conversely from an enacted perspective perceiving a composition of juxtaposed interior and urban fragments and uses. The latter arguably could be seen as akin to the aforementioned re-composing of conflictual heterogeneities. Within the composition, new, unforeseen, and even unwanted insights are framed. The divide between what is normally shown and known and what isn't becomes suspended. This provokes a continuous negotiation of ideas about the public, the private, the communal, the included, the excluded, and so on. Ethical questions arise.

What characterizes both cartographies is the promise of a porosity to be seized in the conjunction [urban+interior]. In this porosity I discern a potential for transformation following a provocation that itself results from a displacement of the interior in the urban environment. The idea of porosity as illuminated in



Figure: 1.41-42 Stills from *Dogville*, showing a cartography of an unmediated relationship between the interior and the urban environment. Stills: Lars Von Trier.

Walter Benjamin and Asja Laci's work *Naples* comes to mind. It doesn't just refer to the material idea of porosity, as in the variety of enclosures existing within the stone or in the white space intruding on the dark spacing of the *poché* technique; porosity is also akin to the idea of a *possibility space* that allows for a continuous re-constructing activity. Following Benjamin and Laci on the notion of porosity, which they situate in the corners, intervals, and interstices of the urban environment, here "porosity results [...], above all, from the passion for improvisation, which demands that space and opportunity be preserved at any price" (Benjamin & Laci 1925). Never is the urban environment stable. Always there are local spaces and opportunities to be seized, potential to be actualized, and values to be re-shifted.

Figure 1.43: Making as a process of making sense of the encounter unfolding in CoMa₀₁, trying to project uses or scenarios of use onto the experience and artifact. Photograph: team CoMa₀₁.



5.2.2. *_[urban+interior]: always an in-the-making / on project and projective-ness*

The idea of a porous urban construct embodying socio-spatial intervals and potentials to be seized by means of the displaced interior implies a kind of substantiating, a certain form of project or making. But how is this making conceived? What is made, and by whom and for whom is it made? This will be the subject of the next paragraphs.

a sense in-the-making, a political urban poesis and an assembled thick urbanism

In CoMa/CoIn, the focus is on *making* urban space through the actual making and (dis)placing of the interior in the urban environment. The notion of *making* touches here once more upon the distinction between the positive political and the negative critical as problematized in previous sections. CoMa/CoIn's interventions are not merely critiquing what they find; they seek a production as well. They reveal and make visible and sensible what is not fully articulated and / or they suggest alternatives to what is known through instances of making. In order to make visible and sensible, CoMa/CoIn deploys a certain aesthetics that expands people's registers of seeing, hearing, thinking, and so on. Thus, the very notion of aesthetics is also amplified. What CoMa/CoIn's interventions make visible and sensible is, as already suggested, the unknown and underexposed, which implies that the conflict that has rendered the unknown unknown and the underexposed underexposed also becomes visualized. Architecture thus conceived never really *is* but conversely is always in the process of *becoming*. It is continually *in-the-making*.

CoMa/CoIn's designs balance reactive critique with political

projection. They are also pragmatic, as they do actual things in order to explore. Following architect and design researcher Markus Miessen, “critical practices [...] can only emerge from the actualities of praxis” and “the purely critical” always has to develop “into the propositional, the applied” (Miessen 2010, p. 183). Miessen goes further, stating that the discourse surrounding the critical has changed fundamentally precisely because it has been brought to practice. This has led to a kind of “spatial enthusiasm,” which utilizes “practical optimism” propelled by “opportunistic curiosity” rather than “theoretical pessimism” (Miessen 2010, p. 75). As a research-by-design studio in and on the urban (environment), CoMa/CoIn deploys such spatial enthusiasm, as was suggested in the introductory part of this thesis. It displays practical optimism and does so with opportunistic curiosity without forgetting its critical and political grounding and orientation.

While the making activity in CoMa/CoIn clearly is not only about materially making architecture, this surely remains an important aspect of it. More specifically, materiality and construction are seen as providing the constraints for a different kind of making: the making of sense. This is substantially different from a more conventional understanding of architecture and urban spaces. The urban environment is not a fundamentally



Figure 1.44-49: The material making in CoMa₀₁. Photographs: team CoMa₀₁.

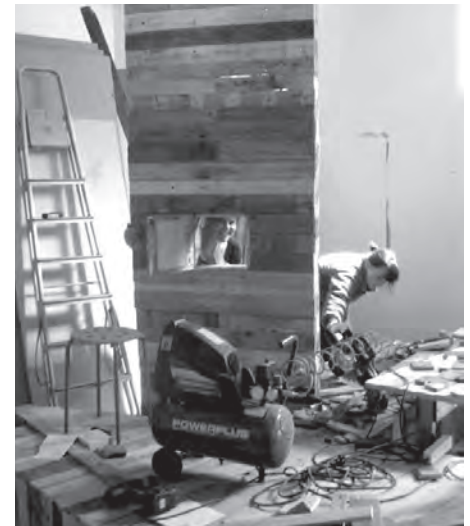

controlled space in which architecture operates as an instrument of control; instead, it is conceived as complex and compromising. It is fundamentally conceived as political space. Architecture operates within the urban environment as a probing, provoking, and poetic instrument.

The idea of the urban environment as a political space is attested to by a variety of authors. Miessen has suggested that urban “space is always many spaces, spaces opposing, spaces co-existing [...]” It is “conditioned by the relationship between humans and their built environment,” producing a socio-spatial construct characterized by “power and force,” but also by “marginality and dissent.” Therefore, space is “entirely political” (Miessen 2010, pp. 67–68). One of the political roles and capacities of architectural artifacts is to bring these different coexisting worlds or spaces to people’s registers and to bring them into negotiation.

It should be noted that, in his argumentation, Miessen often refers to the “micro-political” instead of the political. He speaks of local and site-specific articulations and interventions functioning as “small-scale, local testing grounds for potential change” (Miessen 2010, p. 15), with an emphasis on “everyday phenomena and practices” (Miessen 2010, p. 30). This scale of making can be discerned as well in Saskia Sassen’s work. In the introductory part of this research, I referred to the strategies of *urban poesis* or *urban making* she proposes in order to break away from “official” and “massive-scale,” “subservient” kinds of urban making (Sassen 2006, p. 1). In these latter kinds of urban making, Randall Teal, an architect and researcher in the field of design fundamentals, notes a dynamic of exclusion, which is also an exclusion of the everyday. Excluded is “anything that might be considered disturbing” (Teal 2009, p. 127). Sassen’s idea of urban poesis deflects from notions of making public space as merely producing “public-access space.” It opens the door to the formation of space that is truly public—public space that invites appropriation by those who use and occupy it. As Sassen points out, one should “not confuse public-access space with public space. The latter requires making –through the practices and subjectivities of people–. Through their practices, users of the space wind up making diverse kinds of publicness” (Sassen 2006, p. 2). Contributing through design to making space public is not about merely providing access to others; instead, it is about providing the constraints for the acts of urban poesis enacted by others. According to Sassen, “the making of public space opens up questions about the current condition in ways that the grand spaces of [...] the state or over-designed public-access spaces do not” (Sassen 2006, p. 2). In public-access spaces, only a poor understanding of politics is promoted. Conversely, the political capacity of architecture that I am striving for here conceives of the urban environment as a site of passionate construction that actively seizes the potential in the porous urban construct, inspiring transformation.

As stated previously, Sassen considers the urban environment an ultimately “concrete” political space. Here “non-formal political actors” as well can have a political impact through their practices expressed directly on the street. “Much of urban politics

is concrete, enacted by people,” Sassen emphasizes (Sassen 2006, p. 3). Rancière stated that politics unfold, in fact, “out of place, in a place which was not supposed to be political” (Rancière 2011, pp. 3–4). Conceiving of the multitude and variety of acts of urban poesis that permeate the city, the urban environment appears, in the words of Teal, “thick” and “assembled” (Teal 2009).

The artifacts advanced and produced in *Architecture's Poetic Instrumentality*, such as the complicating machines and interiors, are the stages for a political urban poesis that thickens the urban environment. Although the interventions advanced in this research pertain to the scale of the micro-political and the local everyday, it should be noted that local and global scales (micro, macro, geo) should never be conceived in a dissociative way. As Chantal Mouffe acknowledges, “the global is always constituted in the local, and vice versa” (Mouffe 2010, p. 150), and no scale is more important than any other (Mouffe 2010, p. 122). Accordingly, CoMa/CoIn intervenes on the scale of the local, but in so doing touches upon broader concerns as well.

the morphogenesis in the encounter

CoMa/CoIn's artifacts construct the constraints and conditions for encounters to occur. Such encounters were from the outset connected to the raising of wonder and thought. Returning to Rajchman, starting to think or conceive of the world, of things, differently only comes about when there is an encounter with something that doesn't fit habitual ways of thinking or conceiving, an encounter with something that challenges people's thinking (Rajchman 2000, p. 44).

Essential to the notion of the encounter is the place that is attributed to the contingent. An encounter is something that essentially happens. It is something that is never fully explicated or anticipated. This has implications for the morphogenesis that characterizes encounters. In the case of encounters enabled by architectural artifacts, the designer may work from a hunch and intuition. He or she may point out a direction. However, s/he cannot know, and ideally does not want to know, in advance what will exactly happen. According to Kwinter, an encounter follows a theory of appearance that does not venture from “a confining world already formed and given in advance.” Conversely, he states that “another kind of morphogenesis” is needed, one that is more dynamic and includes all kinds of contingencies (Kwinter 2002, pp. 8–10).

In his work, Kwinter has proposed for architecture a theory of appearance he calls “snow-crystal-morphogenesis.” Such morphogenesis is based on the distinction between the formation of an ice cube and that of a snow crystal. While ice cubes form in controlled ways (“spatialized” ways, Kwinter stresses), snow crystal formation combines controllable processes and movements with contingent ones that result from “external micro- and macroscopic relations.” Thus, such a morphogenesis is not merely spatialized but embedded in time—a time of uncertain creation. According to Kwinter, in the ice cube, “all the aleatory conditions, all of chance, hazard, all virtuality and sensitivity to other disturbances and changes in the environment—all wildness and

openness—are scrupulously (i.e. by design) eliminated” (Kwinter 2002, p. 26). Yet it is only by fully drawing in and engaging with such “aleatory conditions” and the variety of “external micro- and macroscopic relations” encountered that something new may take shape. According to Kwinter, the “snow crystal is literally the product of ‘time,’” and “in its growth and design are one.” In its taking shape, “while falling, the snow crystal incarnates all the chance events, [...] and [...] uses them to assemble itself” (Kwinter 2002, p. 27). The complicating machines and interiors can be seen as following a similar genesis, lending themselves to seizing and being seized by sets of aleatory conditions and varieties of external relations. Construction here is seen as fundamentally shared, engaging all kinds of agents and actants.

Advocating for a sympathetic engagement with such external relations and aleatory conditions, it seems worthwhile to shortly touch upon art critic Nicolas Borriaud’s concept of *relational aesthetics* (Borriaud 2002). From the perspective of this kind of aesthetics, artifacts are judged on the basis of the human interactions and the interactions within social contexts they are able to establish. There is less focus on the artifact or object and more on the artifact’s performances, emphasizing aspects such as audience interaction and participation.

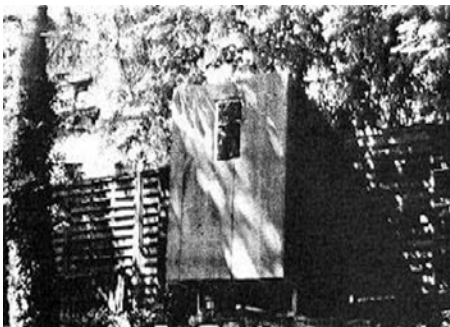

Figure 1.50-52: Wim Cuyvers’s Public House, a small interior built in the interstice between two types of public space, provoking appropriations and interpretations within its users and those who encounter it, leading ultimately to its own destruction. Photograph: retrieved from <http://www.vingerboets.com/>; photograph retrieved from Cuyvers’s Tekst over Tekst.



Exemplifying how I conceive of this snow crystal morphogenesis in this thesis with an architectural example, a specific work of Cuyvers comes to mind. In 2003, he was asked to contribute to the exhibition *Beeld in het Park*. Instead of inserting an autonomous artwork in the confinement of the park, he inscribed a small interior room in the enclosure that fences off the park: the *Public House*. The room simultaneously bears aspects of private space (the interior) and public space. Although the room is an interior, its connection to the public is quasi immediate. Also, it is not owned in usual ways; instead, it can be used in a variety of ways and can be privatized by anyone who wants to. The small interior space contains a chair, a light, a bed with daily fresh sheets, and a table, hinged in front of the door, with which one can close off the small room. It is important that the interior can only be closed off from the inside through an act of privatization or occupation. The *Public House* interior constitutes an architectural

articulation in public space to be encountered. Anything can happen, and the path of the artifact shifts alongside the desires of those willing to occupy and appropriate it and alongside the divergent projections made upon it and by means of it. The *Public House* is thus assumed and assembled in a force field of relations—existing power relations, but also desires that strive to deviate and possibly overturn. In this field of relations, the *Public House* itself functions as a connector. In the artifact, commonly accepted as well as intimate and situated aspects of the public and the private connect and collide. The architectural artifact connects to rules and regulations prescribed by urbanism, by legislation and municipal orders, and by the art institution. It connects to habitual uses based in common sense, delineating what a building in the urban environment is exactly and how one is expected to inhabit it and thus inhabit the urban environment. It connects to the determination of who is a citizen. It connects to a difference of expected and contingent actors, such as the secretive couple spending a forbidden night, the homeless guy, the concerned neighbor, the city council, the police, the building's builders, and those who tear it down. All of these agents connect to the architectural artifact in an architectural time of contingent creation. In this field of relations and in this architectural time, the interior executes a re-distributive agency. It locally recomposes public space and the conceptions of it and re-distributes power by acts of suspending the normal, the habitual, the proper, and the dominant. The *Public House* as such installs *politics* rather than that it polices, using the aforementioned Rancièrian distinction (Rancièr 2011; 2010, p. 37). What emerges is an intensive and conflict-driven space of negotiation sprouting from the inscription of an interior in a specific locus of the urban environment. Thought is shaken up through the provocation of certain uses and appropriations as ways of making sense of the situation. These uses and appropriations are both expected and contingent. They probe the site, and with it people's understanding of public space, expanding an understanding that used to be taken for granted. The city council played its role as an actor in expected ways, first supporting the project and then opposing it, shutting down the space a first time after a series of complaints, then being obliged to reopen it following a claim by the art institution, only to tear it down completely a short time later. One night the *Public House* was opened by the architect and two young children were found occupying the space. According to Cuyvers, these children had understood the invitation of the *Public House* perfectly and had read the unique opportunities it offered them specifically. Following its occupation by two children, the artifact went through a period of discontent and anxiety projected by concerned neighbors, leading to fierce discussions of public interest in the city council and ultimately to the aggressive demolition of the *Public House* overnight. Paradoxically, even the demolition can be considered here as design and part of the artifact's morphogenesis. The artifact does not strive for permanence or beauty as such, as a narrow view on aesthetics would propose. Once pushed through the fence, the *Public House* leaves one with a scar not only in the physical enclosure of the

park but in one's very conception of what public space is. What is revealed is the fact that public space is in fact always a contested political construction, while it is often conceived as common and consensual—that in fact public space is governed and surveyed by hidden rules that become visible through intensive interactions with the artifact. The artifact alternates among different roles: it is a house and a threat, a shelter for temporal desires, a symptom, a political object, an object of anxiety, and so on. A crucial aspect of artifacts as probing, provoking, and poetic instruments is that they only really exist in relation to the connections they enable or are enabled by. Instead of conceiving artifacts as isolated things, here they become conceived more in the sense of “referential totalities”, an existing concept further developed by Teal. Here “materiality is important but not in the form of the isolated things [...], rather it is in the referential totality and its corresponding structures from which emerge understandings of ourselves, the places we inhabit, the things we encounter, and the people among we live” (Teal 2008, p. 14).

In the above discussion, a short reference was made to “policing” politics and “political” politics, a distinction made by Rancière (Rancière 2011; 2010, p. 37). The distinction has been adopted intentionally in these paragraphs dealing with the encounter—not only because it aligns well with cases such as *Public House* and complicating machine CoMa₀₂, but because to Rancière the relation itself between policing politics and political politics must be seen as a generative encounter. I will come back to this more extensively when exploring some Rancièrian ideas on the political. There, I will follow his proposition “to give the name of the ‘political’ to the field of the encounter—and confusion—between the process of politics and the process of police” (Rancière 2011, p. 5).

who makes (in) the encounter

In the encounter, a crucial making role is attributed to all kinds of contingencies. This also includes the contingent acts of all kinds of actors overcoming the architectural artifact. It follows that here the omnipotence of the architect in the process of morphogenesis and design is called into crisis. The making activity in the encounter is no longer situated exclusively in the making architect and in the conception phase of architecture; it is also situated substantially in the reception phase, expressed through spatial and mental occupations, appropriations, and processes of sense-making in those who encounter it. According to Sassen, such a making “through the practices and the subjectivities of people” is an essential constituent in the socio-spatial production of the urban environment (Sassen 2006, p. 2). Drawing on Dunne once more, the user herein becomes a protagonist and co-producer of experience (Dunne 1999, p. 34). The importance of these active practices and participations of people in making socio-spatial reality is underpinned by Miessen, who refers to a “reinvention of what it means to be responsible” (Miessen 2010, p. 48), thereby emphasizing the ethical weight of assuming such a posture. According to Sassen, within the urban environment, the people who use and experience architecture can make new forms of the

social and the political rather than simply enacting what Sassen calls the expected “ritualized routines” (Sassen 2015). CoMa₀₂ can be seen as based on the identification of such a ritualized routine, i.e. the idea to use the sharing of food as a way of bringing people together in order to create the image of a harmonious community. It subsequently counteracts that simplicity, as it were *complexifying* it.

Both the title and the content of Hill’s book *Occupying Architecture: Between the Architect and the User* suggest a similar interest in the possibly unfitting co-creation between the architect who designs and the user who occupies architecture. CoMa/CoIn shares this interest. This does not mean that architects should give up on the capacity of designing (as in Von Busch’s image of chairs that cannot be sat in, ugly vases, and just plain bad designs). Instead, the architect has to become even more crafted in preparing architectural instruments and in pairing the aesthetic and functional with the performative. In line with Van Toorn, CoMa/CoIn acknowledges the importance of the designer designing, introducing some kind of directionality by his or her designs. However, that intention is always infused with and confused by this other model of morphogenesis that sees in the contingent a productive force. Thus, answering the question of who *makes* (in) the encounter brings with it a paradox. Put positively, it contains a productive tension. Aspects of the architect, of the one encountering or using the architecture, and of the contingent forces connecting (to) it are “complicated.”

I insert here one last aspect that relates to the question who is making (in) the encounter. It retraces some of the critiques formulated with regard to critical theory, emphasizing that not everybody is able to *read* its critiques. In architecture, the encounter with something forcing one to think is accessible immediately through bodily and tactile experiences. In this sense, the critical and political here are readable by anyone, requiring only the sensing and wondering body.

5.2.3. _ [*urban+interior*]: a model of participatory making (!)(?)

Considering the making activity in architecture, which runs from the conception phase deep into the reception phase, is CoMa/CoIn to be considered a form of participatory design? And if so, what then is its specificity? CoMa/CoIn is indeed about participation, but it sets up a specific approach. It is true that CoMa/CoIn intentionally breaks away from representational ways of approaching reality, calling the student to engage with urban reality. There they have to consider to what parts of reality they can contribute by means of their designing capacity and designs. A first mode of participation for CoMa/CoIn then is the participation student-designer with the world.

A second instance of participation can be traced in CoMa/CoIn’s commitment to the lived encounter. Whether an intentional user or a contingent passer-by, each becomes a participating stakeholder in the sense that their appropriations, interpretations, and negotiations enter processes of negotiation and from that co-produce sense. Miessen has pointed out that

participation, and participatory design, can explore two kinds of freedom. These are “negative freedom,” as in “freedom from,” and “positive freedom,” as in “freedom to” (Miessen 2010, p. 52). CoMa/CoIn’s artifacts critique and carve out spaces with new possibilities, some of which it actualizes. In the encounter, thus, both kinds of freedom emerge. There is freedom *from* oppressive ideas, such as the established ideas of what public space is, beyond which one hardly manages to think. However, in the work *Public House*, there is also a freedom *to* explore and articulate where one’s own interests lie. Those interests do not necessarily coincide with the designer’s initial intentions. The role of the architect, and of the architectural artifact, is to stage the emergence of these two kinds of freedom without projecting a predictable path and outcome in advance.

The idea of participation as drawing people into encounters can be seen as provoking specific and local intrusions in reality, forcing one to engage with the conflicting forces at play out there. According to Miessen, participation as such is no longer “the default form that promotes participatory planning processes or user-involvement, but [...] a means of a consciously directed, forced entry into a territory, system, discourse, or practice that one is usually part of” (Miessen 2010, p. 53). The idea of participation and the idea of the stakeholder here move beyond a version of participation that grants people an equal involvement in processes of creation and that levels out the dominant role of the designer in those processes. The latter form of participation seeks to render design processes more democratic, thereby correcting them. While CoMa/CoIn values the turn toward participation in architecture, the interpretation given to that notion is considered to always imply dynamics of disagreement too. Always there are processes of intense negotiation running between conflicting ideas. Logics of consensus are not taken to be the sole ruling criterion. As stated previously, admittance of processes of dissensus can be productive within participatory design. In fact, dynamics of dissensus can be seen as a natural part of any kind of participation. And any kind of participation is always political because it is fueled by negotiation. An emphasis on consensus often brings with it an idea of how participants should act (in consensus) and what the participation will lead too (reaching consensus). It could be argued that such participation risks becoming the policing kind rather than the political.

Looking at CoMa₀₂, (Con)Fusion by Cooking, it is clear that the table at which one is seated, far from breaking up demonstrations, invites demonstrations of conflicting ideas and interpretations within the same flat expanse of the table. What then follows is not known in advance but has to play out within the time of construction the table affords. The *Public House* can be seen as operating along similar conflict-inclusive vectors.

5.2.4. _ [urban+interior]: always a question of in-habitability and the inhabiting of worlds

Thinking about the conjunction [urban+interior] as the porous

relationship between urban environment and interior implies that one thinks about *in-habitability* in all of its dimensions. In a simple observation, it is through the interior that in-habitations of the urban environment substantiate. This in-habiting through the interior often comes as an affirmative continuation of habits. But in contrast, there is also the kind of in-habiting that comes as a disruptive way of occupying—a “territorializing,” “de-territorializing,” and “re-territorializing” dynamic, in Deleuze and Guattari’s terms (Deleuze & Guattari 2004). The disruptive way of occupying here refers also to a disruptive way of appropriating ideas and values. As illuminated in previous sections, (in-)habitability is best defined in systemic terms, referring “to the interface and interactions” between inhabitants and world (Findeli 2010, p. 292). That interface is an object of design, attributing to design an ultimately important political role. As Findeli has suggested, the position given to design here is both diagnostic and prescriptive (Findeli 2010, p. 292).

5.2.5. _ [*urban+interior*]: *knowledge in the encounter*

An encounter with artifacts such as *Public House* or CoMa₀₂ produces new insights. It changes and transforms the ways reality, or more precise, a real situation, is seen. This also entails a change and transformation of values, which are themselves always sites of construction. As was illuminated above, in the emergence of new insights and the renewal of values, processes of disagreement are also seen as productive. Considering the *Public House* from this perspective, it is clear that conflicting uses, appropriations, and occupations reveal that the count of existing notions of public space does not suffice. This may lead to new ways of understanding public space.

As I’ve said here previously, architectural artifacts play a fundamental role. To play an active role, artifacts have to deploy mechanisms of interaction—with people, with ideas. In the following paragraphs, one such mechanism of interaction is explored because of its presence in each of the complicating machines and interiors: the mechanism of *affordances*. More precise, in my understanding the notion of affordances can be associated with the aforementioned idea of *preparing, arranging* and *setting* architectural artefacts, so that they afford for processes of reflection and negotiating sense. That said, the notion of affordances positions an agency as well within the artifact itself, an aspect Chapter 2 will connect to in more detail. Another reason for including this mechanism is that it in some way relates to the production of knowledge, as will be shortly discussed.

The term “affordances” as a mechanism was first coined by psychologist James J. Gibson (Gibson 1977). The basic idea is that an artifact or object projects something back onto the intended user. Thus, an important aspect of the mechanism is that there is intentionality not only within the user. Similarly, there is a certain intentionality radiating from the artifact. A table projects that it welcomes one to sit around it. From the artifact, in this case a table, an offer or “recruitment” goes out to the body, inviting it to

use the artefact. In this thesis, I have suggested on several occasions that a *mind recruitment* also sprouts from the artifact, inviting the user to think and construct interpretations through use.

Interpretations of affordances are intriguingly diverse. The mechanism itself can be seen as a site of construction to which a variety of authors have contributed. This has given me the opportunity to advance my interpretation of it, drawing from these interpretations. A different interpretation can already be witnessed between two of the protagonist authors who have elaborated the mechanism. Psychologist James J. Gibson has used a broad, descriptive account. Affordances, in his view, comprise all action possibilities latent in the artifact that are measurable, independent of the user's ability to perceive them, but always related to this user's physical capabilities. However, Donald Norman, a researcher in the field of design and cognitive science, has narrowed affordances down to just those action possibilities that are readily perceived by the user. This has also made the concept dependent on the user's goals, values, and beliefs. Although I consider this difference in interpretation to be productive, Norman's interpretation seems to restrict the possibilities of the mechanism, reducing the number of events to those that are likely to happen. A table projects an invitation to sit around it in ways that are considered proper. If the table does this, it is a good table. Confusion and contingency are not invited guests in this interpretation.

The mechanism of affordances is seen in relation to the production of knowledge by several authors. According to researchers Maier, Fadel, and Battisto, affordances even constitute an alternative architectural knowledge base—more specifically, a knowledge base based “on the success and failure of designs,” replacing “the tradition of transferring [...] knowledge through oral history” (Maier, Fadel, and Battisto 2009). It is the personal interaction and experience with artifacts compared to an archive or history of interactions and experiences that propels the formation of knowledge. In that comparison, according to the authors, there is an evaluation mechanism at work shifting interactions and experiences into the categories of success and failure, thereby expanding the archive. It should be noted that failure here is as relevant as success for composing the archive.

A slightly different and knowledge producing mechanism, remaining however in vicinity of the mechanism of affordances, is the mechanism advanced by Gerard De Zeeuw and Nel Janssens, which underlies what they call “non-observational research” (De Zeeuw, 2011; Janssens & De Zeeuw, 2017). They attribute to the artifact a “channeling” activity. In this mechanism of channeling, the driving dynamic for producing knowledge or insights is not one adding observations to existing observations. Instead, it is experiences that are added to existing experiences (an archive), forging new (improved) experiences. The insistence upon a history of personal interactions as a base for the construction of knowledge also characterizes the work of biologists and cognitive scientists Humberto Maturana and Francisco Varela. They define a mechanism of interaction they call a “readiness-for-action” moving from people towards artifacts. They say that, interacting

with artifacts in the immediacy of any specific situation, one is seized by such a readiness-for-action. One connects to that situation through the artifact, creating what the authors call “micro-identities.” Doing so, one constitutes “micro-worlds.” Varela states that “who we are at any moment cannot be divorced from what other things and who other people are to us” (Varela 1999, p. 10). According to Maturana and Varela, “‘Readiness-for-action’ is key to cognition. It each time triggers personal interactions and every interaction [...] can be assessed by an observer as a cognitive act” (Maturana & Varela 1998, p. 174).

Maier, Fadel, and Battisto have focused on how the evaluation mechanism within the mechanism of affordances somewhat restricts its potential. They see affordances as a tool for improving architecture, which has to be purified by eradicating all undesired affordances. They can be seen as narrowing down the poetic possibilities of a more broadly interpreted version of affordances, to which I subscribe. Yet the authors also acknowledge that “the impetus for any design project can be understood in terms of creating and changing affordances.” They add that the mechanism of affordances should move beyond the aspiration of “creating artefacts to do certain things, as a functional view of design would hold.” They also aim beyond the idea of “creating artefacts solely on the basis of creating a beautiful form.” Instead, they deploy the mechanism “to create artefacts that can be used and that have meaning” (Maier, Fadel & Battisto 2009). Here they leave the door open for affordances that aspire to enable a certain poetic production.

I am intrigued by the concept of affordances because of its ties with the using and exploring human body and its illumination of both motor- and mind-recruitment. I have wanted to utilize affordances in the most productive way possible, away from functionalist or purely aesthetic views. One way to do so is to allow some degree of estrangement into the mechanism. Giving a simple example of affordances as laid out above, a photograph and illustration of a table are inserted here. Two small branches disturb the engram of the table as it is known, while the table remains functional. The table radiates that it intends to be used as a table. At the same time, the addition of two branches allows wonder to arise and thought to unfold.

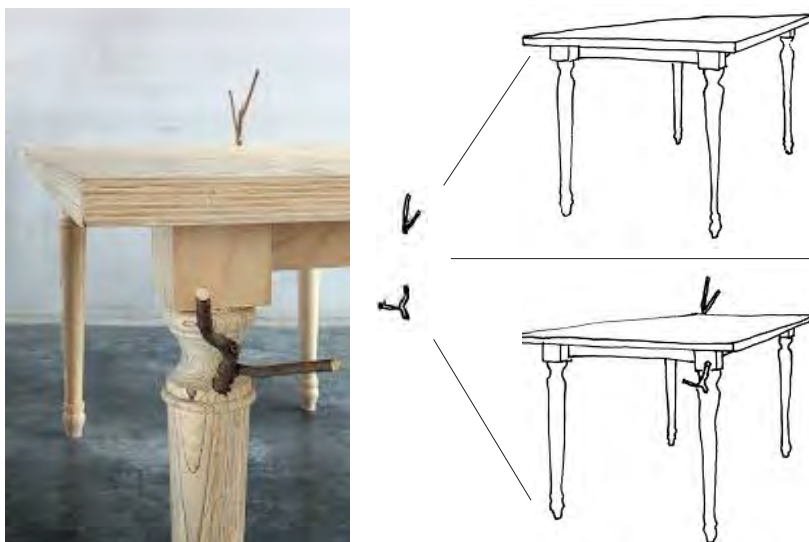

Figure 1.53-54: Table by De Vylder Vinck Taillien, showing a slight deviation from the engram of the table we hold in our minds, a deviation in the form of two branches constituting a certain user-unfriendliness, provoking us to wonder. Photograph: Filip Dujardin; illustration: Johan Liekens.

Connecting back to CoMa₀₂, it is the subtle deviations from the engram of the table imprinted in one's mind and ingrained in one's using body that enables wonder to arise, thought to unfold, and sense to be made. In the encounter with the table, through its deviations, new insights or incremental bits of knowledge may occur.

5.2.6. *[urban+interior]: urban articulations that temporally de- and re-territorialize knowledge*

CoMa/CoIn produces temporal articulations in the urban environment through a displacement of the interior, making latent or underexposed things visible within the time and space of the encounter. I see temporality here as linked to Miessen's observation that architecture is never able to deliver definite solutions. What it can do, he argues, is "visualize and spatialize the conflicts that are the reality of its context" because increasingly "these conflicts are disappearing from our visual registers" (Miessen 2010, p. 103). A similar reasoning can be found in Mouffe. I will come back to such reasoning immediately. Miessen speaks of a "situational potentiality" (Miessen 2010, p. 172) that is present in a situation and can be seized through the mechanisms of visualizing and spatializing. In my understanding, seizing such a situational potential is akin to a local and temporal production of insights and incremental bits of knowledge.

Figure 1.55-56: *Tents at the cemetery of Rozeebeke, Wim Cuyvers. Photograph: Wim Cuyvers.*



Figure 1.57-58: *Stills from a film about the intervention, showing fierce discussions but also sympathy, infusing interpretations that speak of scandals with interpretations that perceive the tents and those using them as good company to deceased loved ones.* Retrieved from <https://www.youtube.com/watch?gl=BE&v=yFSOXr6pbr4>.



It seems relevant to introduce here one more artifact by Cuyvers: a group of tents placed in the cemetery of a small Belgian village. Cuyvers placed this group of tents in close relation to the grid of graves. The intervention is developed here once more in terms of the amount of connections and negotiations an artifact can bring about. Through the intervention aspects of public space reveal themselves. With the heterogeneous juxtaposition of tents and graves, Cuyvers targets the contingent passer-by, the informed visitor as well as the local community. The tents, which can be occupied by anyone who wants to, became the subject of intense discussions and debates that played out in the cemetery. Some images of these heated discussions are added here, taken from a short film documenting the intervention. In Cuyvers's vision, the cemetery is one of the last truly public spaces left in the urban landscape. Gideon Boie, an architect-philosopher and researcher in the field of politics of architecture, stated that in this work it is precisely the rare absence of any form of economic pressure, any form of claiming, and any form of interest that constitutes the cemetery as a truly public space (Boie 2008, p. 122). For Cuyvers, the cemetery is primarily an existential public space rather than a functional one. It should be noted that Cuyvers's intervention clearly carries a directionality: an invitation to think about (the scarcity of) existential public space. However, the outcome is uncertain. The tents arouse animosity and are seen equally as a potential. The animosity comes from perceiving the tents as a violation of the sacred character of the cemetery, a disturbance of what is called peace and rest. The potential lies in, for example, an elderly woman perceiving these tents as company for her deceased husband. Or in perceiving the tents as a means to overthink the intimate relationship between life and death. Or in finding a public space where one can just *be*. No effort is made to exclude or favor interpretations. It opens up a space and stage for multiple possibilities to be negotiated. While that negotiation coincides in time with the life of the tents on the cemetery and thus is temporal, a residue of it left in one's experiencing body makes one see things differently.ed.

5.3. CoMa/CoIn: A POLITICAL RECALIBRATING PRACTICE

From the beginning, aesthetics has its politics—which, in my terms, is a metapolitics, a manner of doing politics otherwise than politics does. (Rancière 2011, p. 8)

In the previous sections, the traits of CoMa/CoIn were laid out, introducing an affinity with the dynamics of a productive dissensus. Drawing on experiences in architectural practice and having contributed to the education of (interior-)architects for more than a decade, I argue that such affinity could serve the conceptualization of architectural practice. There is often a bias toward aesthetic, functional, and economic suitability and compliance. All too often an architect is seen as an uncritical provider of services and form and a deliverer of solutions. Specifically, this affects the realm of interior architecture, since

its role is often associated with “improving” reality in the form of creating nice atmospheres and tailoring precise fits. While discussing the design of CoMa₀₂, (Con)Fusion by Cooking, the students sympathized with the potential of productive conflict, but they found it hard to stick to the idea. They repeatedly slipped back in the notion of a harmonious fusion. I argue that what surfaced was a trained reflex each time to return to logics of consensus. Miessen suggests that there is evidence that disagreement is currently lacking and needs to be trained (Miessen 2010, p. 86).

In previous sections, I showed how that (even critical) architecture often refuses the role of being critical. The suspicion with regard to the potential of a productive disagreement is undoubtedly connected to this. In many cases, architecture has become, in Van Toorn’s terms, un-critical and a-political (Van Toorn 2006, p. 57). Rancière has pointed out that the very description of what it means for an activity to be political is itself currently completely “permeated” and “suffocated” by the notion of consensus (Corcoran 2010, p. 4). As was attested before, this has important consequences with regard to casting ahead and substantiating alternative futures, an activity Dovey has called a condition of any architecture calling itself architecture (Dovey 2007, p. 258).

5.3.1. *the aesthetic political: doing politics differently than politics does*

On various occasions in this thesis, I have made reference to the necessity of developing *other* perspectives on aesthetics in architecture. This section addresses that necessity by lingering on the intimate relationship between politics and aesthetics. In line with Rancière, aesthetics are conceived as having a politics of their own, and accordingly politics are considered to have an aesthetics of their own. Since my research is situated in architecture, itself an aesthetic field, the emphasis would logically be on the perspective of a politics of aesthetics. However, the focus here is double and *confused*. It starts by conceiving as inextricable the relationship between politics and aesthetics. When approaching the relationship from the perspective of an aesthetics of politics, Rancière suggests that this has to do with politics “becoming visible.” Here new “fabrics of perception” are woven (Rancière 2010, pp. 139–41). As I’ve already shown, artifacts such as those produced in CoMa/CoIn and in the practice of Cuyvers, for example, have indeed assumed that role of visualizing (and spatializing). Reversing the perspective to a politics of aesthetics, Rancière points out that aesthetics has its own way of doing politics, which he labels as a “meta-politics” (Rancière 2011, p. 8). This aesthetic manner of doing politics, according to Rancière, “achieves what will always be missed by the ‘purely political,’ that is freedom and equality incorporated in living attitudes, in a new relationship between thought and the sensory world, between the bodies and their environment” (Rancière 2011, p. 9). Hence, aesthetic activities and practices such as architecture are able to pick up aspects of politics that are overlooked by the field of

politics itself. More specifically, aesthetic activities mediate the political in the immediate surrounding of the practices of people.

Before furthering the exploration of an aesthetic manner of doing politics, the notion of the political used in my research must itself be further clarified, starting from its most basic interpretation. As already suggested, the political here does not primarily refer to the kind of politics that regulate society (i.e. state politics, governmental practices, political parties). Conversely, the political here is interpreted as similar to these everyday practices of people in reality. Thus, the political is the political within reach of anyone. This means, as stated previously, that non-formal political actors are also included. In my research, the political is also always seen in relation to encounters happening in reality—encounters in which artifacts play fundamental roles. That implies that politics here are always seen in close relation to particular capacities of architectural artifacts. The next paragraphs will illuminate the range of concepts that delineate in their intertwinement the notion of the political I use.

In a problematic and basic interpretation, some have considered the political that runs through architecture as simply the production of new possibilities (e.g. Kwinter 2002, pp. 11–12). The political is seen here as a positive variation of the critical. As argued previously, it is of key importance how this positivity is conceived. In Kwinter's interpretation, all action is understood as positive, draining the political potential from the political. A more promising interpretation of the political, relating it with the critical, can be found in Mouffe. The scheme illuminates a dynamic continuum of instances of *articulating*, *dis-articulating*, and *re-articulating*. Mouffe states that critique cannot come from withdrawal or critical “dis-articulation” alone. Constructive “re-articulation” is needed just as much. To merely dis-articulate, according to Mouffe, would render critique to be “pure dissemination.” Mouffe emphasizes that social reality is “discursively constructed,” attributing an important “structuring role” to the political as a discursive process of dis- and re-articulating. What is needed, she argues, is a strategy of setting up “counter practices” that “subvert the dominant” and bring about the new (Mouffe, 2012). The artifacts developed and adopted in my research answer Mouffe's call, setting up practices that have this discursive political function. The *Public House* can be seen as dis-articulating stratified ways of conceiving space as public by articulating alternative and dissenting viewpoints, leading subsequently to the re-articulation of the notion of public space, which contains instances of both the old and the new.

As stated previously, I refuse to conceive the political as apart from its potential relation to and impact on society. Mahmoud Keshavarz, a researcher of politics of design, and Ramia Mazé, an architectural designer and researcher of critical and participatory design approaches, have proposed an definition of the political as “concerned with how society is constituted as the organization of human coexistence.” In this they pay particular attention to the role of artifacts and to processes of design as “one of the practices that organizes human coexistence” concerned with “how identities, subjectivities, and collectivities are posited”

(Keshavarz & Mazé 2013). This strengthens the idea that design, as an aesthetic activity, is always political because of this particular mediating role. Similarly, Mouffe notes that architecture and other creative practices “play an incredibly important role, because they provide different forms of subjectivities from the ones that exist at the moment” (Mouffe 2010, p. 119). As such, it mediates people’s grasping or in-habiting the world.

Turning now to another aspect of the political already touched on in my research, there is always a form or idea of participation present. Politics are conceived here as including and giving voice to *others* in processes of constructing sense. Drawing on contemporary political theory, Mouffe distinguishes between *associative* and *dissociative* perspectives on politics. The associative perspective sees politics as “acting in concert.” Mouffe links this view with how participation is most often deployed. Conversely, the dissociative perspective, to which she subscribes, “has to do with the dimension of conflict, the dimension of antagonism [...] that exists in human societies” (Mouffe 2010, p. 124). Rancière’s account aligns with this in its suggestion of two ways of approaching reality and, bringing this specifically to the reality in which architecture is operational, two ways of approaching public space. As mentioned previously, he labels one *policing* and the other *political*. These approaches have radically different aspirations:

Police interventions in public space consist primarily not in interpellating demonstrators, but in breaking up demonstrations. It consists, before all else, in recalling the obviousness of what there is, or rather of what there is not, and its slogan is: “Move Along! There is nothing to see here!” The police is that which says that here, on this street, there’s nothing to see and so nothing to do but move along. It asserts that the space for circulating is nothing but the space for circulation. Politics, by contrast, consist in transforming this space of “moving-along,” of circulation, into a space for the appearance of the subject, it consists in re-figuring space, that is in what is to be done, to be seen and to be named in it. It is the instituting of a dispute over the distribution of the sensible. (Rancière 2010, p. 37).

The *policing-political*, or policy, guards and affirms the established and proper—that which is agreed upon. The *political-political*, conversely, sets up an activity of recalibrating the sensible—the sensed as well as common sense. The political-political, I argue, characterizes the artifacts of my research, as was shown in, for example, the demonstrations by the complicating machine CoMa₀₂ and by *Public House* that recalibrate parts of the posited conceptions of reality.

5.3.2. *_dynamics of dissensus*

I want to elaborate further on the inextricable relationship between politics and aesthetics that Rancière describes, and on the role it thereby attributes to the dynamics of “dissensus”

(e.g. Rancière 2010; 2011). Working from the perspective of an aesthetics of politics, there is dissensus in the sense that in reality some things are rendered visible / audible / tangible while others are not, thus constituting the constraints for a struggle. The idea here relates to architecture in the sense that architecture (politically) assists in organizing reality. It organizes a “space-time sensorium” of “being together and being apart,” of being “outside or inside,” Van Toorn argues. Architecture here “is political in the manner in which it makes reality visible by means of its own aesthetic syntax [...] giving it direction” (Van Toorn 2006, p. 60).

The system that regulates the proportion between that which is made visible and that which is kept invisible is what Rancière calls “policy – the police.” Conversely, the term *politics* refers to any activity that resists that proportion, making it subject again to negotiation. It is the ongoing struggle between policy and politics that Rancière considers to be producing an instability from which creation as the formulation of alternatives can unfold. Intriguingly, the unstable relationship between policy and politics is related by Rancière specifically to the encounter, stating that “politics has no proper object” and that “all of its objects are blended with the objects of police,” which leads him “to give the name of the ‘political’ to the field of encounter—and ‘confusion’—between the process of politics and the process of police” (Rancière 2011, p. 5). Thus the political, according to Rancière, is an “encounter between two heterogeneous processes”: that of *policy*, which “creates community consent” and distributes proper places and functions, and that of *emancipation*, which is the more political dynamics (Rancière 1992, p. 58). Politics work in concert with policy. Rancière asserts that the political has no field of its own. Conversely, politics occurs “out of place, in a place which was not supposed to be political” (Rancière 2011, p. 3). It follows that politics is not an autonomous activity but rather a heteronomous one, as is aesthetics (Rancière 2011, p. 11). Neither having a field of its own, they build their stages in one another. Important here is the fact that Rancière adds that “the quality between police and politics has no vocabulary or grammar, only a poetics” (Rancière 2011, p. 6). That relationship is first and foremost a site of ongoing construction.

The political working of an artifact such as CoMa₀₂ is revealed through a certain aesthetics that gives voice to those who encounter, interpret, and occupy it. In Steven Corcoran’s words, it allows for a “local restructuring of the field of experience” (Corcoran 2010, pp. 17–18). It allows for “a new scenery of the visible and a new dramaturgy of the intelligible” to appear that “reframe[s] the world of common experience” (Corcoran 2010, p. 19). Deviant performances intermingle with the usual proper ones. The sensible (both common sense and that which is sensed) is thereby recalibrated. Artifacts such as CoMa₀₂ and *Public House* demonstrate that the issue of (architectural) space is to be conceived in terms of *distribution*. This is a “distribution of places, boundaries of what is in or out, central or peripheral, visible or invisible” (Rancière 2011, p. 7).

Following now the reversed perspective of a politics of aesthetics, the focus is on the political dimensions implicit

in aesthetic works and artifacts. Central to it is the idea that within aesthetics there are processes of leveling out dominant and dominated discourses. What becomes addressed here is the power of aesthetics to create and transform reality on that basis. In addition, politics has this transformative power, though it is less directly accessible. Thus, aesthetics and politics have a “common nature” that, according to Corcoran, is centered on “their innovative potential to disrupt forms of domination.” Corcoran emphasizes that, indeed, “the freedom of the aesthetic [...] is based upon the same principle of equality that is enacted in political demonstration” (Corcoran 2010, p. 15).

In aesthetic practices as in politics, according to Rancière, there are no proper genres and no proper practitioners. There is no such thing as a destination or specific competence of specific individuals to practice aesthetics or politics. Both should be conceived of as accessible to and practicable by all. There is “no political life, only a political stage,” Rancière asserts. Political action, then, according to Rancière, “consists in showing as political what was viewed as social, economic or domestic” (Rancière 2011, p. 4). Adding to this, Rancière does not reduce politics to “exceptional and vanishing moments of uprising,” instead claiming that “there is politics in a lot of ‘confused’ matters and conflicts” and that in these “politics makes for a memory, a history” (Rancière 2011, p. 5). The idea here that aesthetics and politics (all creating practices as well) are in reach of everyone is read by practices such as CoMa/CoIn as an open invitation to create such a history. The challenge they perceive here is to use aesthetics as the stage from which the political can take off.

5.3.3. *_ dissensual politics as the building and recalibrating of worlds*

In the discussion above, I suggest a relationship between aesthetics and the construction of worlds and worldviews. Worlds are not stable and given but continuously being (constructed) through processes of dis-articulation and re-articulation. Following Mouffe on this, “we are not born with ideas of the world” but instead create “subjectivities within the context of a multiplicity of practices.” Accordingly, “the idea that we have of the world, of who we are, of what our shared values are [...] is constructed through this multiplicity of practices, of which cultural practices [...] constitute a decisive part” (Mouffe 2012). Worlds and worldviews are thus primarily sites of construction. In these, values are construed, shared, and contested. When one subscribes to the idea that worlds and worldviews are continuously in the making along the vectors of dis-articulation and re-articulation, one subscribes to the implicit presence of certain degrees of friction and conflict. Rather than culminating in a unified worldview, the construction here points to the coexistence of different worlds in one and to the processes of negotiation among them.

Mouffe’s concept of “agonism” (Mouffe 2010; 2012; 2013) and her insistence that aesthetic fields deploy agonistic practices within public space seems helpful here. Her concept of agonism

refers to the idea of a common ground and to shared values held therein, which nonetheless can be interpreted differently and divergently. One world is many worlds. A divided commons is thus the reality of worlds. As stated, Mouffe thinks highly of the role aesthetic and cultural practices can assume in this construction of worlds by providing the stages for agonistic processes. Architectural artifacts conceived in this way become “tools to conceive the world anew,” in the words of Cliff Stagoll (Stagoll 2005, p. 26). A similar estimation can be found in Rancière, who asserts that aesthetic practices can indeed “produce a new perception of the world, and therefore [...] create a commitment to its transformation.” In this Rancière delineates the conjunction of three processes: the “production of a strangeness,” the “development of an awareness of the reason of that strangeness,” and the political “mobilization of individuals as a result of that awareness” (Rancière 2010, pp. 142–43). Strangeness here comes as a “a process of dissociation: a rupture in the relationship between sense and sense, between what is seen and what is thought, and between what is thought and what is felt” (Rancière 2010, p. 143).

Architecture and its artifacts are thus uniquely equipped to help construct worlds and worldviews. It should be noted that the aforementioned porous relationship between interior and the urban environment, which serves as the primer of CoMa/CoIn itself, relates to the idea of world-making. This relationship was revealed above as dealing with broad notions of *in-habitability*, referring also to the in(-)habiting of world(s). In fact, philosopher Jean-Luc Nancy stated that “to inhabit is necessarily to inhabit a world, that is to say, to have there much more than a place of sojourn” (Nancy 2007, p. 42). The conjunction [urban+interior] establishes this in-habiting, which goes beyond the idea of merely having a place of sojourn, by conceiving of the inscription of the interior within an urban context in a poetic way.

In *Ways of Worldmaking*, philosopher Nelson Goodman emphasizes that *worldmaking* must not be understood as a movement toward a world as a unified entity. Quite the contrary, “the movement is from unique truth and a world fixed and found to a diversity of right and even conflicting versions or worlds in the making” (Goodman 1978, p. x). Here these different versions are not considered multiple possible alternatives to a single actual world. According to Goodman, conversely, there are multiple actual worlds coexisting (Goodman 1978, p. 2). There are many world versions “of independent interest and importance, not reducible to a single base” (Goodman 1978, p. 4). Goodman’s reasoning implicitly suggests the idea of politics as a playing out between versions, some of which are underexposed, unrecognized, and oppressed. Rancière too has related politics with world-making, characterizing his own work in terms of attempting to show politics not merely as “the exercise of power or the struggle for power,” but contrarily as “the configuration of a specific world.” There is politics because there are competing worlds (Rancière 2011, p. 7).

Thus, a world is not something out there as a fixed and unified entity to be discovered. Conversely, “worlds are as much ‘made’ as

that they are found and to know a world one must make a world.” Here “comprehension and creation happen together” (Goodman 1978, p. 22). Similarly, philosopher William McNeill notes that one must conceive a world more like a “tone”, an “attunement”, a specific “gathering” in which some possibilities are opened up while others never occur to us. Hence, in making a world, there is an active process that selects this and leaves out that, thereby re-assembling new worlds. The unique gathering defines a world, and in changing that gathering a world becomes another world. In this gathering, design and design thinking, according to McNeill, play a fundamental role (McNeill 2006).

The making of worlds in *Architecture's Poetic Instrumentality* aligns with the above, constituting a poetic act in which worlds form themselves but in which in this formation an important role is also attributed to design and design thinking. This is specifically true for the urban environment, in which I have situated my making activities. The urban environment can be considered an ultimately intense form of world-making based on an oscillating interaction between spatial materializations and social processes.

5.3.4. *— dissensus as a suspending and redistributing activity*

Consensus is an agreement between sense and sense, in other words between a mode of sensory presentation and a regime of meaning. (Rancière 2010, p. 144)

Dissensus is a conflict between a sensory presentation and a way of making sense of it. (Rancière 2010, p. 139)

Dissensus [...] is a political affair in which everyone is challenged to constantly position themselves in the arena of quotidian experience. The quality of such an antagonistic constellation consists in coalitions and antithetical terms, in a “politics of aesthetics,” [...]. (Van Toorn 2006, p. 60)

In the above discussion, politics and aesthetics were advanced as domains of human thought and action that have common one specific characteristic: “their contingent suspension of the rules governing normal practice.” Both work from an “innovative leap from the logic that ordinarily governs human situations.” Accordingly, they “effect a redistribution of the sensible” by producing “forms of innovation that tear bodies apart from their assigned places and free speech and expression from all reduction to functionality.” What politics and aesthetics manage to do is to “introduce new subjects and heterogeneous objects in the field of perception” (Corcoran 2010, pp. 1–2).

Both political and aesthetic activities cut across what exists, decomposing and recomposing the borders and the assigned place of what was considered stable and proper. This includes, as stated previously, cutting across aesthetics’ and politics’ own assigned place, function, and genre. In previous sections I proposed to deploy a broadly interpreted mechanism of affordances to counteract such purist functional assignment. Also, closely related

to the notion of poetics, it was revealed that one may gain from resisting the functional assignment of the proper genre by means of *foregrounding* the language of architecture.

What safeguards the functional assignment of what is proper is, as suggested, policy. Policy is seen here as tightly connected to the idea of consensus, the essence of which is “the supposition of an identity between sense and sense, between a fact and its interpretation” (Corcoran 2010, p. 2). *Dissensus*, in contrast, introduces an impropriety (a strangeness, a gap) between sense and sense. It inserts “a conflict between a sensory presentation and a way of making sense of it” (Rancière 2010, p. 139). While consensus and policy are associated with common sense, dissensus shows the common as essentially divided, setting as such the contours of a political poetic stage. This stage, in Rancière’s words, “re-frames the given by inventing new ways of making sense of the sensible, new configurations between the visible and invisible, and between the audible and the inaudible, new distributions of space and time—in short, new bodily capacities” (Rancière 2010, p. 139). Mouffe has made mention similarly of a “counter-hegemonic struggle” (Mouffe 2012).

The deployment of dissensus as a political practice can be seen as related to Mouffe’s promotion of *antagonism* and *agonism*. In line with Rancière’s association of politics with dissensus, Mouffe acknowledges that “the dimension of the political is something linked to the dimension of conflict that exists in human society, the ever-present possibility of antagonism: an antagonism that is ineradicable” (Mouffe 2010, p. 107). To Mouffe, consensus without exclusion is unattainable, which arguably guarantees the permanent presence of politics. Mouffe distinguishes between two ways in which the dimension of antagonism can be expressed in society. One she calls “antagonism proper—the classic friend-enemy relation,” the other “agonism, as an alternative way in which oppositional positions can be played out” (Mouffe 2010, p. 92). Agonism establishes what Mouffe calls a “conflictual consensus.” There is an agreement on shared principles, but a disagreement on the interpretation of these principles (Mouffe 2010, p. 102). Concretizing the above discussion for this research as it relates to architecture, one might think of the aforementioned demonstrations of an agreement on the importance of public space, while disagreeing on how this is to be interpreted. Thus, the artifacts here contribute to the construction in the public realm of agonistic stages, where different interpretations can be played out while principles remain shared.

It should be noted that Mouffe not only distinguishes between two ways of expressing antagonism but also between two kinds of pluralism, a notion often associated with ideas of both participation and politics. One view of pluralism conceives plurality as the fact that there are circulating different points of view, different interests, and different values. It states that, while one is unable to embrace them all, they nevertheless constitute a harmonious ensemble. Another view on pluralism, the one Mouffe clings to, is rooted in the certainty that “all these different and multiple views cannot be reconciled,” implying a dimension of antagonism. Here the idea of a harmonious ensemble is

considered nonsensical. As Mouffe emphasizes, “accepting the fact and existence of pluralism implies, therefore, accepting the fact of antagonism, of conflict. Conflict that is ineradicable, that cannot be reconciled. In fact, that is exactly what I understand as antagonism” (Mouffe 2010, pp. 124–25). It is intriguing here to retrace for a moment Goddard’s perception of an irreconcilability of too many possibilities and interpretations of these demonstrating at Wexler’s *Community Table* and CoMa₀₂’s installation of a time of passionate negotiation between such possibilities and interpretations. In both the stage is given to a feast of difference—to the unfolding of an antagonistic pluralism.

As stated previously, Mouffe accords to aesthetic practices such as architecture “an incredibly important role” in the creation of what she calls “agonistic public space” (Mouffe 2010, p. 119). Such practices construct for this the necessary surfaces (Mouffe 2010, p. 109). In her lecture *Democratic Politics and Agonistic Public Spaces*, Mouffe adds that what these practices then in fact substantiate are ideas of the world, allowing people to reassemble or rearticulate their ideas of it. As noted previously, these ideas are not merely given to people, nor is one born with them. Instead, people make and construct ideas of the world within a multiplicity of practices. Among this multitude, aesthetic practices such as architecture are of the utmost importance and potential.

★_6.

SHIFTING THE EXPERIMENTING GROUND

At this point, I want to briefly touch on some aspects of one particular complicating machine, as it resonates to a certain degree with the artifacts that will propel Chapter 2 of this thesis.

During the discussions with my colleague Eva Gheysen, who co-directed the studio in 2015, and with the student Jelke Soenens, we discussed an exploration of the “infra-thin dimensions” and capacities of the wall as an architectural element. At the same time, in the architecture firm I am part of (STUDIOLOarchitectuur), as architects we were in the midst of building the Walled House project, the protagonist artifact initiating and propelling Chapter 2 of this thesis. It should be noted that the Walled House project served as one point of reference for the student at that time while she was undertaking her own experiments and explorations on the element wall. This suggests (and this has always been my understanding of things) that between the different architectural practices and experimenting grounds of my research there has always been a fertile interplay, notwithstanding that the different experimenting grounds here are clearly different and have different potential. I simply add two images of Soenens’s intermediate artifact(s) here, showing in one of the images a linear landscape composed of wall



Figure 1.59-60: A landscape of walled fragments proposed by Jelke Soenens as part of the 2015 Complicating Machines studio. Photographs: Eva Gheysen, Johan Liekens.

fragments erected at full scale. These fragments all referred to some particular recollected experiences the designer had lived *in the shadow* of urban walled constructions. More importantly, there was the aspiration to now affect those who encounter them through a recollected and recomposed artifact, inspiring them to engage in a recollecting and recomposing activity themselves. While in the pictures the fragments are clearly encountered in a hall somewhat severed from public space, following more the logics of an exposition, it was the intention of the student to recompose the fragments into a whole that could be erected as a free-standing wall within the city. Once (dis)placed out there in

the city, it would await the encounters produced.

By inserting the above artifact, an abridgement is made between the artifacts of the educational context of the CoMa/CoIn studio and the artifacts developed within the contours of the professional architecture firm STUDIOLoarchitectuur. These latter artifacts propel Chapter 2 of this thesis and all attribute importance to the wall as an architectural element and its displacement in the urban environment. In Chapter 2, the critical, political, and ethical capacity and aesthetics of architecture is thus explored alongside what I call a micro-political aesthetics of walled artifacts.

There are different reasons for shifting the experimenting ground toward professional architectural practice, a shift that was already set up in the early stages of my research. One of these reasons relates to time. It relates to an aspiration to displace artifacts in the urban environment beyond the duration of the temporal intervention. I already advocated for forms of *slow* architecture when discussing the methodological approach of my research, but here I also hint at the endurance of effects and affects unfolding in the encounters with artifacts. Similarly, there has been some disappointment, as I've stated previously, with regard to the testing of the complicating machines and interiors. To the students, the ten weeks they were afforded to devise, construct, and deploy their artifacts was too short to allow for a productive testing. Little time was left for the emergence of contingent and possibly dissenting encounters, which initially were the aspiration of the studio. It should be noted that on a few occasions the complicating machines and interiors devised and constructed have effectively been tested in intended ways. I refer here to, for example, the photograph depicting the contingent encounter between one of the students and an old man, who stared at one another mediated by the shutters of complicating machine CoMa₀₁. It should also be noted that other important aspirations were conversely reached in each of the built complicating machines. That is, an awareness emerged among the students of their artifacts' potential agency with regard to re-calibrating reality, thus re-orienting their design attitude.

Another reason for shifting the experimenting ground can be situated close to this, reconnecting to my advocacy for experiencing architectural artifacts in a state of distraction. It could be argued that the complicating machines and interiors have been handed over partially or largely to the contemplating eye and body. While they have engaged with their compromising socio-spatial urban surroundings, they were not always really assumed in them. In the encounters they provoked, they immediately stood out strangely. Standing out thus, in my understanding, impedes the strange from becoming experienced and productive only through use, which would accord better with experiencing architecture in a state of distraction and with the very idea of encountering. It also impedes on whatever these artifacts can produce, because whatever would happen is already largely announced and does not become apparent gradually and delicately through use and experience. I argue that, for architecture, the typical way of being approached in a state of

distraction is an important asset. It is precisely because architecture usually functions in the background that a bringing to the fore (a foregrounding) holds such potential to be productive. Jeremy Till, an architect and researcher in the social and political aspects of architecture, drawing from sociologist Henri Lefebvre, considers the everyday as “the site that contains the extraordinary within the ordinary, *if one is prepared to look*” (Till 2009, p. 139, original emphasis). It is in the everyday that “creative energy is stored in readiness for new creations” (Lefebvre cited in Till 2009, p. 140). It is a state of relative absence, of everydayness and ordinariness, that allows something to become subtly but productively present. According to Till, “just as much design skill” is needed herein, “but that skill is deployed quietly in setting a social scene rather than noisily in constructing a visual scenography” (Till 2009, p. 134). I consider some of the artifacts of this chapter to be in that sense a bit too loud (not deploying their skill quietly enough), which has driven me to reorient the experimentation on less loud adventures.

Relating to this, one may think of a pair of phone booths on which the artist Sophie Calle performed slight alterations on a bustling street corner in New York in response to a challenge raised to her by the novelist Paul Auster. Performing subsequent slight alterations that reorient and intensify the experience of those who encounter them over time, Calle can be seen as delicately probing the latent potential of a local urban site. There is an important aspect of materiality to be found here that also relates to the genre of architecture. The acts performed by Calle of writing words onto the phone booths, of adding flowers and connecting props to them, all point to the addition of a materiality that is somewhat alien to the situation. This to me increases the challenge of conceiving ways in which one can work or become affected by slightly re-articulating the usual flesh and genre of architecture, only giving way to wonder slowly, as a consequence of slight alterations and ambiguities crafted within the usual architectural flesh (and genre).

The critique I formulate above on the artifacts of CoMa/CoIn may also apply to some architectural practices concerned with architectural agency in which the architect as an initiator plays a role that supersedes the role of the architectural artifact itself. In some of these, the artifact becomes only one of the props; it is not the very stage for the mediating and connecting. While the agency of the designing architect is important, I am particularly interested here in trying to reach into the realm where artifacts are received. It follows that I have invested specifically in exploring the agency of architectural artifacts themselves. Therefore I sympathize more here with critical, political and ethical artifacts in which the designer is relatively absent. This has not been the case in some of the complicating machines and interiors, where the role of the designer was that of the initiator.

With regard to this moment in which the experimenting ground shifts, I wish to introduce a comment made by Dyrssen during a presentation of developing research projects. On that occasion she encouraged one presenter to change his experimenting ground because the situating of his research within



Figure 1.61: Sophie Calle's phone booths altered with props. Photograph from the book *Double Game* by Sophie Calle.

a professional architectural practice hindered experimentation. In that instance, in relation to that research project, I agreed with this stance. In my research, however, I intentionally want to shift the orientation now exactly towards this restricting reality of architectural practice. This may seem paradoxical, but as suggested I assume that exactly here there is the basis for further exploration that is both intriguing and needed—in less loud and immediately present but more delicate and refined ways. Paradoxically, it would seem, there is a challenging aspect to the restrictions inherent in architectural practice. The next chapter will thus venture resolutely into the territory of this other experimenting ground. By introducing artifacts from the architectural office I collaborate in the intention is to shift the experimenting ground toward what many may consider the center of architectural practice, if such a thing exists. An additional reason to do so is that I want to have the full, complex, and compromised body and tissue of architecture and of the urban environment in front of me rather than an ideal selection.

In the movement announced above, the experimenting ground thus shifts towards the particular agency of architectural materiality and articulation. To oversimplify a bit, I have turned to the brick arranged in the brickwork wall, expecting it would draw nearer to the encounter that arises first and foremost as a site of construction that initially is never fully out there to be contemplated.

In the above discussion, I have illuminated some of the reasons for shifting the experimenting ground of *Architecture's Poetic Instrumentality*. Connecting all of these has been a desire to experiment with the poetic instrumentality and the critical, political, and ethical capacity of architectural artifacts not as an alternative to architecture. Conversely, it has been my intention to situate experimentation exactly in the center of architectural practice (again, if such a thing exists). Here I align with Cuyvers, who stated in the A+ publication titled *[Re]politicize!* that in the quest for a more political architecture he is not searching for an “alternative architecture” (Cuyvers 2016). The artifacts adopted in Chapter 2, I argue, are not the kind one finds in openly activist and participatory political practices of architecture. They are related to these, but work in different ways, based more on everyday reality and working with it to work against it. As is suggested throughout my research, the *other ways of doing architecture* aimed for are a promise and capacity of architecture itself, not an alternative to it.

CHAPTER 2

*exploring
a critical, political, and ethical capacity
of architectural artifacts
in the experimenting ground of
the architecture firm*

STUDIOLOarchitectuur

★_7.

A WALL IN A PRAIRIE SOMEWHERE

In Paul Auster's novel *The Music of Chance* (Auster 1990), the reader follows a man on a journey across a landscape. Then the journey suddenly comes to a halt, zooming in on a prairie where two men are in the midst of building a wall. As the back cover of the novel tells us, the reasons for constructing that wall—and continuing to construct it—in that prairie by those men will never be rendered fully clear. The only certainty we can have, then, is that chance has played a fundamental role. In my reading, aside from the agency of chance but relating to it, the other fundamental and complex agent that propels the narrative is the wall construction itself—how it executes its multiple and ambiguous agencies over the terrain, affecting and connecting all other kinds of agents present in it.

I introduce Auster's wall here because it quickly helps set up some key aspects of relevance to Chapter 2, which deals with what I refer to as a *micro-political aesthetics of walls*. I will go into some of these aspects as a way of introducing this chapter, well aware that an encounter with that wall is best followed either in one's own imagination by exploring the novel or in the lived experience situated on site.

Relating to Auster's wall, there is an aspect of time that intrigues me. At first we are on a journey, and then suddenly we find ourselves in a prairie where a wall is being construed.

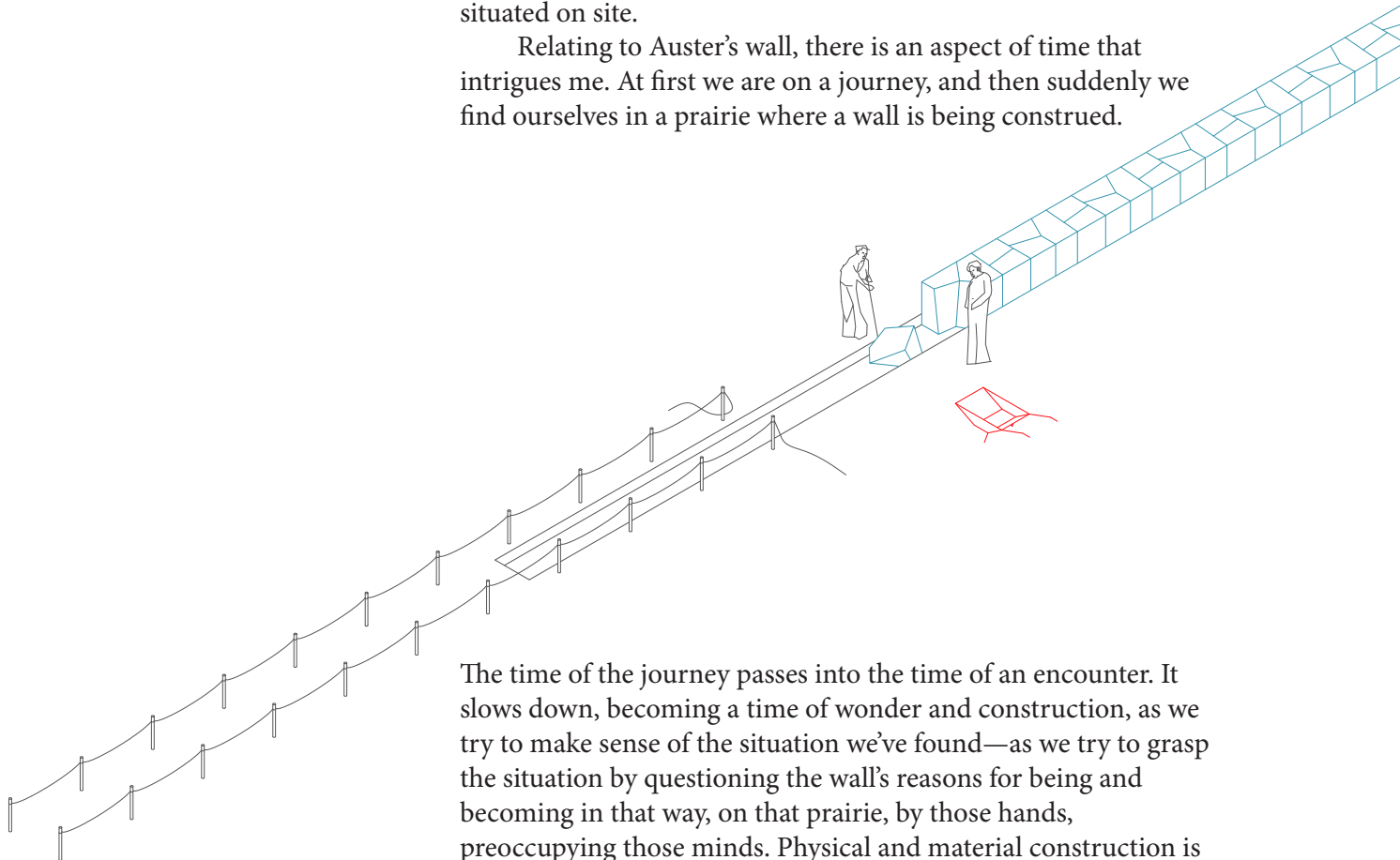

The time of the journey passes into the time of an encounter. It slows down, becoming a time of wonder and construction, as we try to make sense of the situation we've found—as we try to grasp the situation by questioning the wall's reasons for being and becoming in that way, on that prairie, by those hands, preoccupying those minds. Physical and material construction is continually doubled with the construction activity of *making (up) of sense*. As suggested, no clear-cut answers will or can be provided; there is no intent to provide them. What is essential are the multiple dynamics of negotiation—a physical negotiation of the wall over the terrain that is paired with a negotiating sense for which the wall is the ultimate vehicle. In these dynamics, as noted, chance plays a fundamental role, rendering the narrative more

complex by further spreading the number of designing agents.

Auster's wall is the very terrain and instrument of connection. It is the material thing according to which and on which everything will be weighed and projected throughout the story: actions, interpretations, sensations, contestations, and sense. As becomes gradually clear throughout the novel, the interpretations given to and the appropriations made of the wall

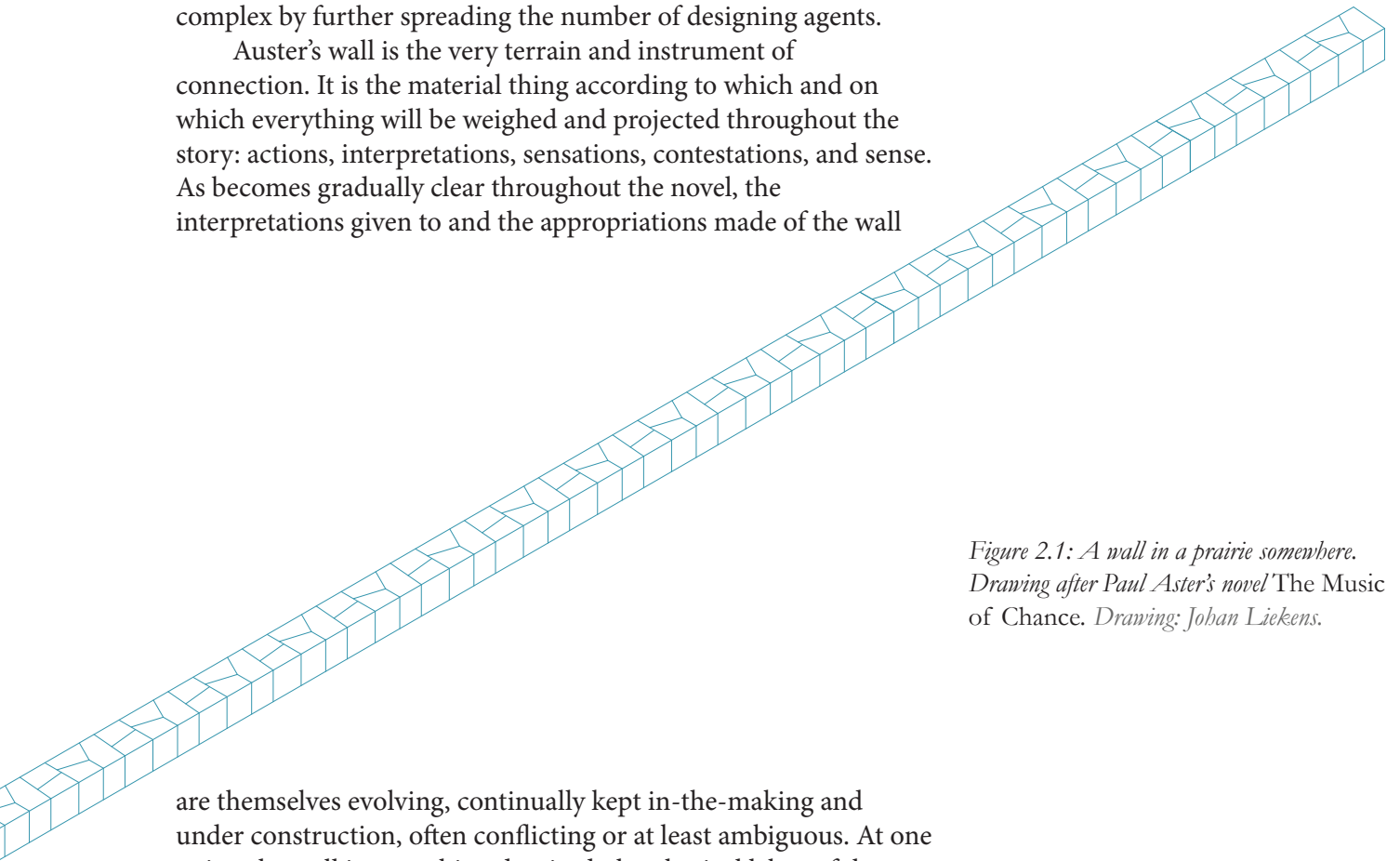

Figure 2.1: A wall in a prairie somewhere. Drawing after Paul Auster's novel The Music of Chance. Drawing: Johan Liekens.

are themselves evolving, continually kept in-the-making and under construction, often conflicting or at least ambiguous. At one point, the wall is something despised, the physical labor of the constructing activity even sensed as an existential threat to those constructing. In another moment, the wall acts as a last beacon of sanity. At yet another moment, the construction of the wall becomes a common effort that delivers enormous gratification, only to become moments later the object of dissent again. Auster's wall has an ultimately complex character. More than an architectural object or element as such, it is a poetic instrument that probes the assemblage of which it is part, to which it is connected, and in which it functions as a connector. The result of that probing and connecting activity is not predictable in advance. It is principally poetic, evoking as well as constraining itself to a making. It is experiment, kept in suspense, suspending definite meaning.

In Auster's novel, the constructing of the wall in the reality of the prairie runs in parallel with the constructing of that same wall in a scale model in a nearby house. The scale model merely follows and imitates the construction of the wall in the meadow, imitating as well the events unfolding in the reality of its shadows. While the model thus follows mere logics of representation, in the meadow the logic is that of encounter and event. of freshly making reality within the moment(um).

Another intriguing aspect that can be related to Auster's wall is the paradoxical pairing of simplicity and complexity. It is the ultimate simple (and quiet) architectural element *wall* that serves as the stage or primer for far more complex (louder) adventures to unfold. This simplicity, I argue, is strategic. As I showed previously, this strategic pairing constitutes a generous moment: architecture here moves to the back(ground) in order for adventures, encounters, and events to occur and unfold.

I have been fascinated by these aspects, which continue the course of this thesis already set out in Chapter 1 (complicating machines and interiors developed in an educational context). Chapter 2 will evolve around a passion for constructing *walled artifacts*, which are seen as probing, provoking, and poetic instruments—membranes, borders, stages, and constraints instituting in turn forms of being, becoming, and belonging. Some walled artifacts will be discussed extensively, while others will only be touched upon briefly. Thus, a heterogeneous landscape of walled artifacts will emerge, substantiating a particular contribution to the general scope of this thesis. I make mention of a particular contribution, since, as suggested before, with Chapter 2 the experimenting ground of this thesis shifts toward *professional architectural practice*.

Another shift is noticeable, however. In the concluding sections of Chapter 1, the emphasis moved from architectural artifacts' assumed critical capacity to their political and ethical capacity. In this chapter, that political and ethical capacity will be further explored in relation to a pragmatist approach to architecture. This may seem paradoxical, since in Chapter 1 pragmatist approaches appeared at times in opposition with the very idea of critical, political, and ethical capacities. That version of pragmatist approaches appeared as *cool*, promoting a just-do-it attitude. However, one of the aspirations of Chapter 2 will be to (re-)introduce the critical, political, and ethical through a pragmatist approach to architecture. I will return to this repeatedly.

Before going into Chapter 2, some other issues need to be addressed. I add them in random order. A first issue relates to the question of why the particular exploration undertaken in this chapter is deemed necessary. A most evident answer would be that such an exploration makes research and one's own design practice coincide, furthering both and thereby constituting *research-through-practice*. In my case, a professional design practice has closely and with alternating intensity followed my teaching and research practices, though always intermingling to a certain degree. Of course, the interest in the research topic existed throughout my adventures in architecture and before the doctoral research took off. In this chapter, though, I will specifically address authored and co-authored projects that have emerged within the time span of this thesis. This is also the case for the complicating machines and interiors that propelled Chapter 1. If this thesis shows a conglomerate and heteronomous landscape (as a construction itself) of (co-)produced artifacts and thought, and of referential concepts and cases as well, then all of these have unfolded within that time span.

Returning to the question of why the particular exploration undertaken in this chapter is deemed necessary, I refer back to the aspiration to answer some urgent calls addressed to artistic practices such as architecture. These calls, as suggested previously, relate to some of reality's urgent matters of concern, shared also between disciplines. In this, a relocation straight into the restricting reality and the *center* of architectural practice and within the full complexity of urban environments is to be

considered a strategic choice.

A second issue relates to the notion of the instrument and thus connects to the mention of a poetic instrumentality in the title of this thesis. As stated before, I am well aware that a conflictual contraction is present in this title. However, this has always been the intention, the aim being to bring into productive tension the often-reviled notion of the instrumentality of artifacts with the poetic production I hold they are capable of. I have witnessed on several occasions the aversion that arises whenever the word *instrumentality* is pronounced in relation to ideas on architecture. First, it seems it is hard to imagine architectural artifacts as instruments, because this would reduce their quality. Seen as instruments, they are understood to be dull, docile, and servile means to known and repeatable ends. However, to align once more with Rossi, as an architect I have always been particularly intrigued by the architectural artifact conceived as an instrument. More specifically, I have been intrigued by how to prepare it as a provoking, poetic, and probing primer or stage to be (dis-)placed in urban surroundings, unfolding reflection and action there. It follows that the notion of the instrument and instrumentality will be very much present in this chapter.

A third issue I wish to address before setting out is that I have redrawn (aspects of) each of the walled artifacts incorporated into this chapter. This process and method of redrawing has served to grasp more purposefully some important moments of difference, growth, and dissent in these walled artifacts. As such it can be read as a persistent way of following these walled artifacts throughout their emergence, their making, and their being in-the-making. To exemplify, the drawings of the Walled House will demonstrate an intriguing difference between how a house was designed and how it was built. The drawings of the Research Studiolo, in turn, show a house growing through the addition of fragments to become an assemblage of fragments. I have chosen to redraw the walled artifacts mainly with the technique of isometric projection, in which all three dimensions remain dimensionally accurate rather than foreshortened to create the illusion of perspective. This drawing technique favors no dimension, and to me this makes the walls most accessible. Beyond this, such an isometric drawing, not being a standard feature of CAD programs, is itself a vehicle for meticulously annotating what has happened to artifacts throughout their contingent path of coming into being. In similar ways, I have from time to time made architectural models, which to me operate more as figments of the imagination and a way of substantiating ideas than as discursive representations. They are also able to reveal some controversies and noise.

I want to add one last thing here in introducing this chapter. Venturing into the vicinity of the walled artifacts of this chapter arguably implies that one moves close to ideas on tectonics in architecture. I hint here at architectural tectonics in the sense of (walled) elements simultaneously fulfilling instrumental tasks and evoking experiences. A variety of ideas on architectural tectonics have already been developed in relation to the architectural element *wall*. Quite often, however, the interplay between

materialization and evocation is conceived as very much ordered and the connection as direct. Architecture's matter and materialization here merely represent or symbolize a meaning that is intended to be transmitted. One frequently encounters the idea that highly technical transparent facades represent transparent ways of governing, thereby symbolizing the transparent kind of society in which the building is erected. The correlation between the two and the meaning transmitted are then considered to be immediately and unmistakably understandable to all who encounter that walled artifact. I intend to stay far away from the kind of direct connection that projects a pre-conceived meaning onto those encountering and perceiving the walled artifact in this chapter. On the contrary, I seek to experiment with the linkages between materializations and what they are able to evoke—both reflection and action. Thus, I do not intend to surrender tectonics as the relationship between a material substantiation and an act of evocation to the world of architectural technological innovation, substantiating the idea in spectacular interfaces loaded with pre-conceived meaning. Instead I will argue, through experimentation and practice, for a challenging account of tectonics that operates as a site of construction in which architectural matter and materialization help evoke action and reflection in those who encounter the artifact. The point of interest in Chapter 2, conversely, is the deployment of a genuinely critical, political, and ethical capacity of architectural artifacts in the everyday urban environment, approached through experimenting on the architectural element *wall*.



Figure 2.2: A walled artefact, found one day in a meadow. Photograph: Johan Liekens.



Figure 2.3: Brickwork constructions displaced in the urban, view from my study desk. Photograph: Johan Liekens.

★_8.

THE WALLED HOUSE

Before turning to the main protagonist artifact of Chapter 2, the Walled House, I will first touch briefly on another urban corner house we designed at STUDIOLOarchitectuur: the Hogeweg Corner House. I insert this corner house here as a prelude to the far more ambitious Walled House project. Though modest, the Hogeweg Corner House intentionally aspired to make a certain impact on its urban surroundings.

On a small lot of scarcely sixty square meters of buildable area, heavily constrained by urban planning regulations, we were challenged to design a home for a family and pair it with a small graphic design studio. A long period of design ensued, in which each internal articulation was meticulously weighed. How the house is organized and lived in, however, is not the subject here. The subject is another aspect of the corner house: its use of a double façade that mediates the connection between the house and the small public space on which it borders. While the outer facade is designed to be an enveloping brickwork scale (shell), a second facade is offset slightly to the interior, creating an interstitial zone for circulating from one floor to the other. In the drawings, that second facade is delineated with a red contour line. Carefully perforating both the inner and outer façades, thereby establishing either correspondences or discordances, enables or mediates views both into the house and out onto the small public space. What emerges is a facade that itself has a lived depth, breathing a certain porosity while at the same time providing a degree of separation without separating.

The corner lot is situated at the convergence of three streets, one of them opening up a new urban quarter, making the corner a spot of a daily and intensive traffic. The space between the lot and the streets, with an impressive tree in its middle, constitutes a small public space. From early on in the design we thought of positioning the entry to the house on that small public triangular square rather than on the front facade, as the client initially requested. By doing so, and giving this space a specific dimension, the entry itself can become a space that is more than just a hasty passage from one environment to the other. Situated at the back of the side facade, it is designed as a deepened recession into that facade, a node that connects house, square, and garden. The recess allows one to lean back and from within the wall observe the square and the daily hustle of passers-by. This view is accompanied by the murmur from the pub where each day eight green plastic chairs positioned with symmetric precision, backs against the pub's façade and facing the public square, await their users and the stories they hum.

Given the scarcity of space within the interior, fusing this shortage with technical considerations and an ambition to make something happen on the square, the entry space to the house is accompanied by an external staircase that protrudes from the outer scale of the house and hovers above it. While it relieves the tightness of living within the house, it also reduces the insulated envelope of the house. In the upper part of the house (at the base

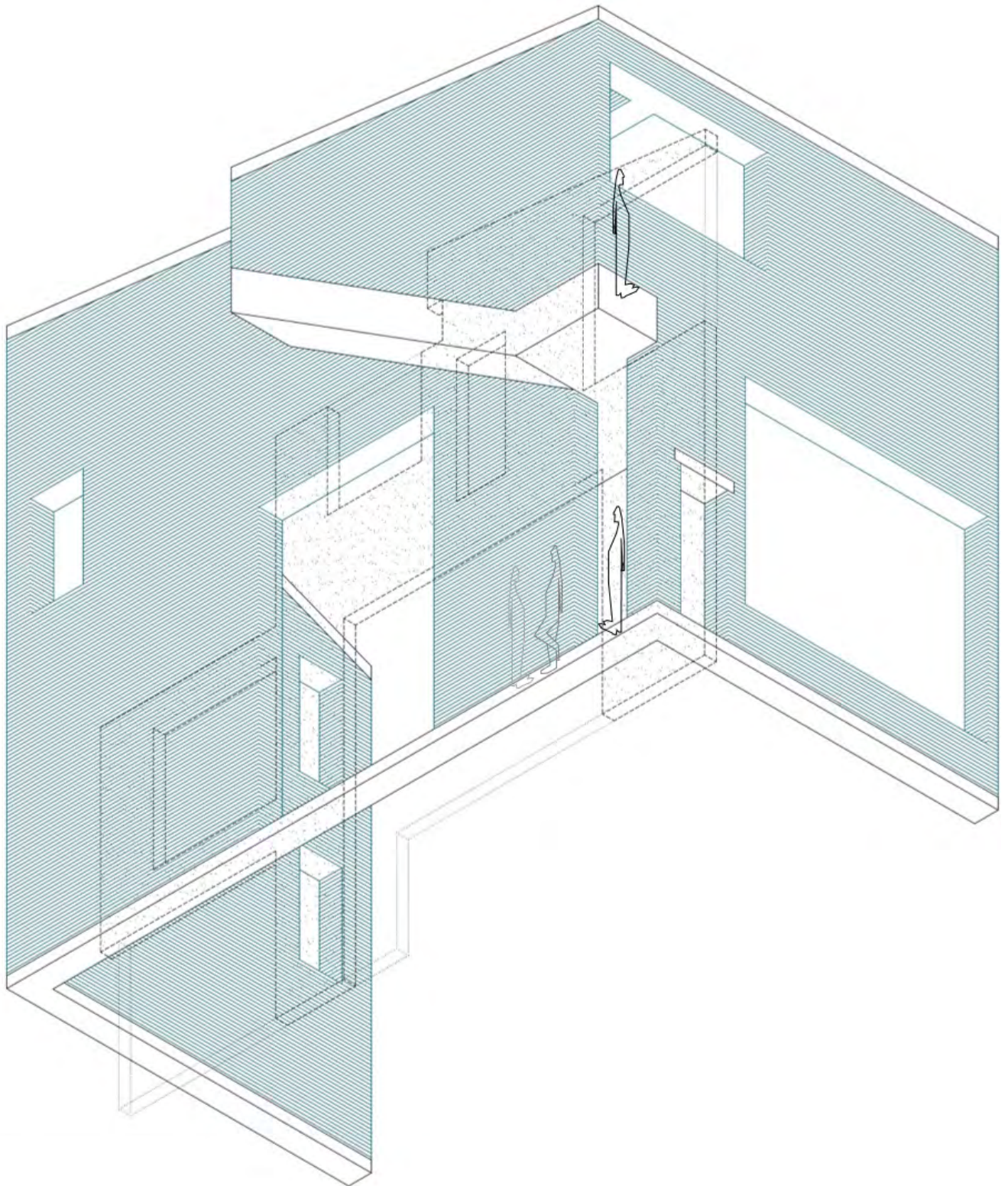

*Figure 2.4: Hogeweg Corner House.
Drawings and photographs:
STUDIOLOarchitectuur.*

of the external staircase) it provides a small outside space linked with the sleeping room and offering a view onto the remnants of two Roman burial mounds. Here, on a sleepless night, one can get out of bed to gaze up into the sky. This small space is also where the man who lives here sneaks out to smoke his daily cigarette. From here one ascends the external staircase to access a roof terrace over half the building. Here a wide overview of the house's surroundings opens up, and through a carefully articulated niche designed into the wall of the staircase a view is opened onto the pub and its lively borders. Due to the protruding

Figure 2.5: Plans Hogeweg. Drawings: STUDIOLOarchitectuur.

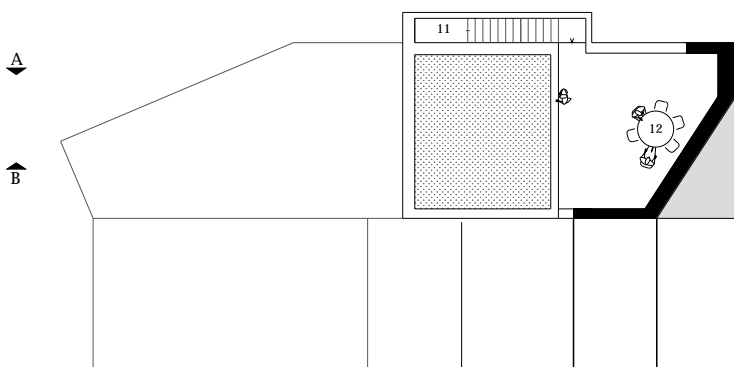
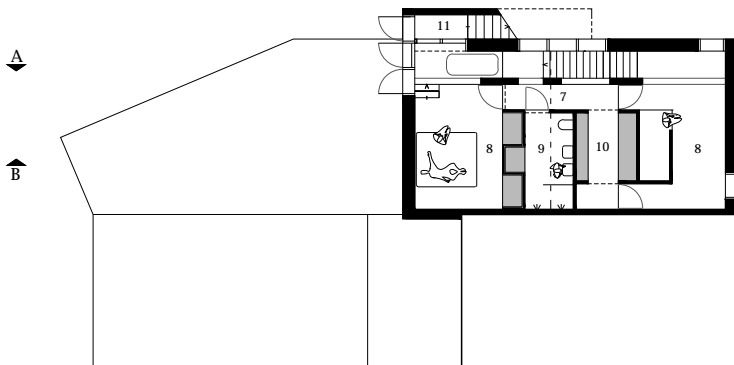
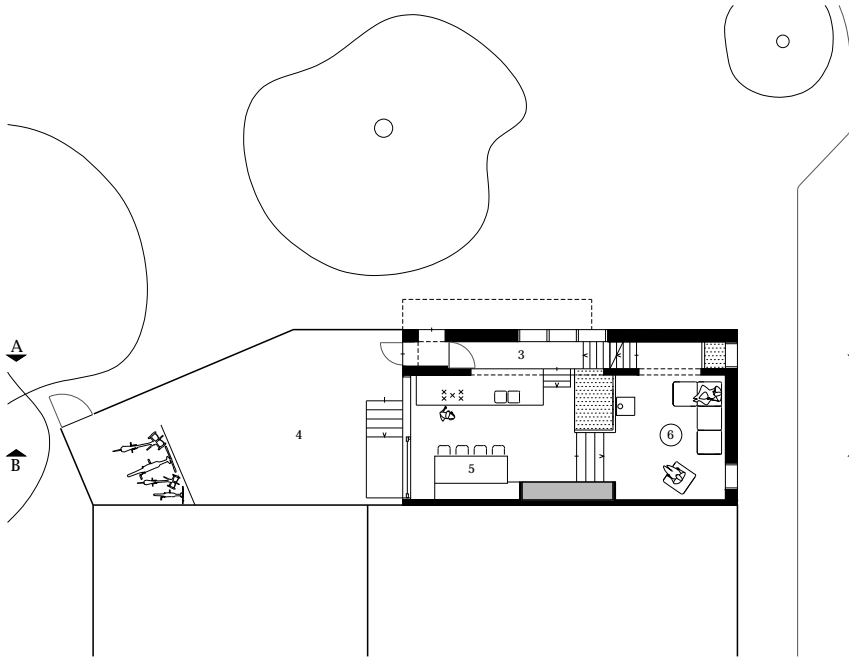
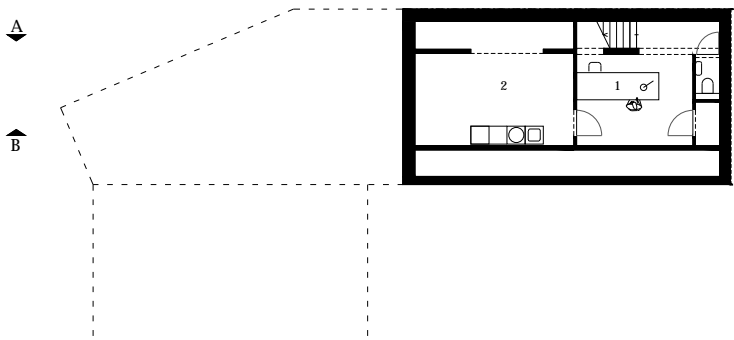

1. studio
2. storage
3. hall / cloakroom
4. garden
5. kitchen
6. living room
7. nighthall
8. sleeping room
9. bathing room
10. dressing room
11. exterior staircase
12. roof terrace



Figure 2.7-8:
Corner House Hogeweg.
Photographs: STUDIOLOarchitectuur

staircase, another zone becomes suggested. Directly beneath the owner smoking his cigarette, in the seam between house and square, a small linear zone offers shelter from the typically wet Belgian weather. As I pointed out, while the ambition is modest, relating to the ostensibly banal and everyday practices of people living in the city, that ambition has been clearly present when thinking and constructing the house. The project aims for an urban *poesis* triggered by the materialization and articulation of an architectural artifact. Venturing from this corner house and its modest but firm ambition, I will scale up that ambition to expand on the materialization and articulation of the walls of the Walled House project.

Illustrated below are two more projects that ran concurrently with the design and construction of the Hogeweg Corner House and the Walled House, which will be discussed momentarily. These projects were also developed as contributions to SOG's Urban Lots program (see next section), and give a taste of our specific approach to architecting (in) the urban environment.

Figure 2.6: Section and façades Hogeweg.
 Drawings:
 STUDIOLOOarchitectuur:

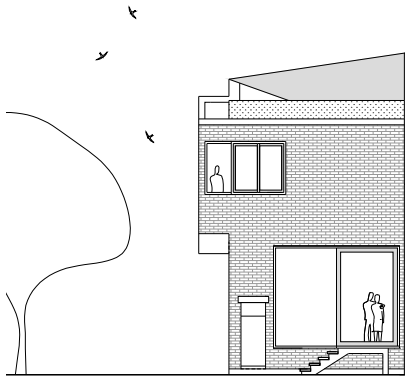
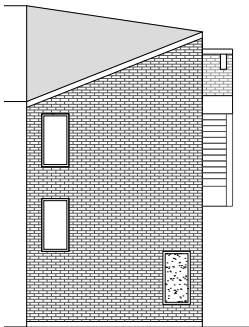
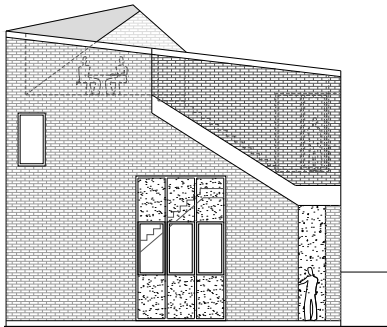
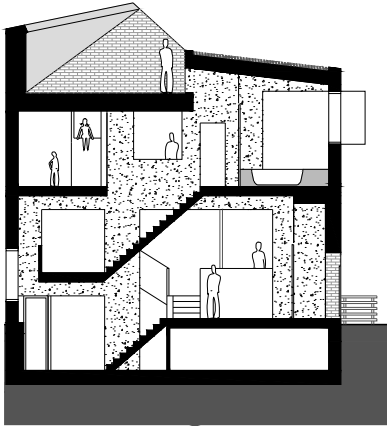



Figure 2.9-10: Project Spadestraat, situated near the Ghent Canal Zone and the urban beach planned there. This project develops around a beach cabin, positioned between the private home and its surroundings, to be used for all kinds of leisure activities. It has two sets of a series of three doors, one set opening onto the street, the other onto the interior, enabling the residents to determine the connection between public and private themselves. Thus, the beach cabin serves as a two-directional porch. Design and photographs: STUDIOLOarchitectuur; model: Johan Liekens.

Figure 2.11: Project De Harduvinjlaan in its current state, situated on a small corner lot in Ghent. One of the challenges the future inhabitants raised was to find a solution for the lack of garden space. We crafted a house in which an ultra-small side garden on the street level connects to a segmented vertical garden incorporated within the overall structure of the house, giving way in turn to a large rooftop terrace. The structure of the house enables this movement of interconnecting gardens while also mediating the sense of connection with surrounding urban space. As is the case with the Walled House, which will be discussed shortly, the intention here was to fully embrace the urban context and design a sophisticated and filtered relationship with it through specific architectural and material articulations. Design and photograph: STUDIOLOarchitectuur.





*Figure 2.12: The Walled House.
Design: STUDIOLOarchitectuur;
model: Johan Liekens.*

* *_the Walled House*

It's my corner, after all. It's just one little part of the world,
but things happen there [...].
(Auggie Wren in the movie *Smoke*, 1995)

The Walled House came into being as an entry to an open architectural competition launched by SOG, the urban development visioning organization for the City of Ghent. One of its initiatives, launched in 2007, is a project called Urban Lots (*Stedelijke Kavels*). Governmental financial incentives are used to procure problematic urban sites, such as decaying housing clusters or challenging vacant lots. These are first cleared and subsequently divided into low-priced building lots. Each year, around ten of these sites are offered to a selected pool of future owners, the intention being to develop innovative urban row houses on them. In the program, there is a specific interest in problematic corner lots: due to their high visibility, they are esteemed to be able to serve as landmarks and models that could stimulate a further reappraisal of neglected urban neighborhoods. The strategy here is to counteract the increasing exodus of young families with acupuncture-like injections into the urban tissue of inspiring architectural interventions that show that a qualitative life in the city is still possible. It is clear from the way the Urban Lots program is conceived and organized that the notion of architecture having a certain agency is already established—that is, the agency of a built architectural artifact to induce change within the socio-spatial constellations in which it is inscribed.

The architecture firms who participated in the competition

were assigned a corner lot in the Ledeberg district of Ghent. A fully developed design project for a private house had to be worked out and presented, and it needed to somehow convey the above-mentioned notion of agency. First a professional jury selected six entries. Subsequently the future occupants of the house would make a further selection based on the design proposals and a series of conversations. While the contest thus only intended initially to identify a pool of potential firms, not the realization of one of the design proposals, the new owners of the corner lot singled out our proposal, which was an intense collaboration between STUDIOLOarchitectuur and Koen Matthijs, to become their future home. Thus, we would be engaged to move from the house as designed to the house as built. I make this distinction here because it will shed light on some important (and, I will argue, political) differences. In our project as designed, several other notions would accompany the aforementioned notion of agency. I will come back to that.

Before going into a description of the project, I will first describe the building site. During the competition phase, there was only a general and thus somewhat abstract idea about the preferred client when thinking of counteracting the withdrawal of young families from the city. In visiting the street corner, that vagueness about the client was paired with the intense and concrete reality of the urban context in which the house would be inscribed. It was a bustling urban site, the sky full of overhead power lines and their tensioning cables hung from houses and massive poles, electrifying the air; a grinding racket rising from the tracks as trams wrenched their way through curves, mingling with a multitude of sounds underscored by the din from the nearby highways; zebra crossings, shark teeth, serial

Figure 2.13-15: The hectic surroundings of the Walled House. Photographs retrieved from Google Maps.

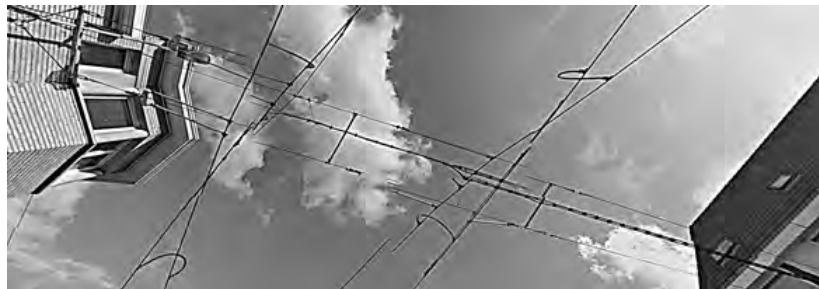

and parallel lines, all of them desperately trying to constrain the movements of various actors moving in various speeds and directions, their bright white wet materiality not granted even the shortest time to dry out on the dark asphalt. Surrounded by all these unconstrained movements, one freezes; surrounded by the dazzle of all these simultaneous sounds, one is outvoted. This all added up to a sense of overall confusion on the site, and yet at the same time it gave the site its intense vitality, a vitality we wanted to work with. Such was the time and place of the corner on which we would propose a house. Such was the space on which a home would be grafted. In laying out the house, the (dis) placement of a brick wall would prove to be an essential act—a brick wall that encompasses a private home on the site, but just as importantly a brick wall that enables other kinds of inhabitations, appropriations, and occupations to occur and gain footholds on the overall site.

* *_the house that was designed: laying out the house*

In what follows, I give a detailed insight into the Walled House project to make several agencies present and to shed light on the official program in relation to the *corrections* we planted into its flesh.

The house we proposed can be seen as developing from the intimate, from within, unfolding from the interior while increasingly engaging with aspects of the urban environment. Never was it our intention to deny the house's vibrant urban setting and radically retreat from it. On the contrary, we wanted the house to foster a strong passion for the city. Thus, a refined balancing of the intimacy of family and individual life with a passionate engagement in the phenomenon city had to be devised, and for a variety of actors and occupants. It follows that the Walled House will also be discussed alongside the notions of communication and non-communication. I am convinced that architecture must be conceived as much in non-relational terms as in relational terms, as philosopher Graham Harman points out in his lecture *What Objects Mean for Architecture* (Harman 2013b, *Architecture Exchange Series #1*). Harman even claims that “non-relationality is creating space rather than relationality” and that “if everything was relational, there would be nothing to build.” According to Harman, both urbanism and architecture are not about simplifying space but about rendering it more complex. The emphasis is not on “smoothing” space but rather on “making edges” in it, making borders and boundaries. These add (to the socio-spatial construct of the urban) “hermetic” spaces and spaces that are “held back in reserve” within the urban environment idealized as a continuum. The Walled House thus works on the axes of both communication and non-communication, mixed into a complex(-ified) rather than a simplified construct. Laying out the borders and boundaries of the Walled House, constituting edges within the urban environment, we imagined intriguing forms of agency being grafted onto the site and becoming active there.

Figure 2.14: Plans and sections of the Walled House as built. Drawings: STUDIOLOarchitectuur.

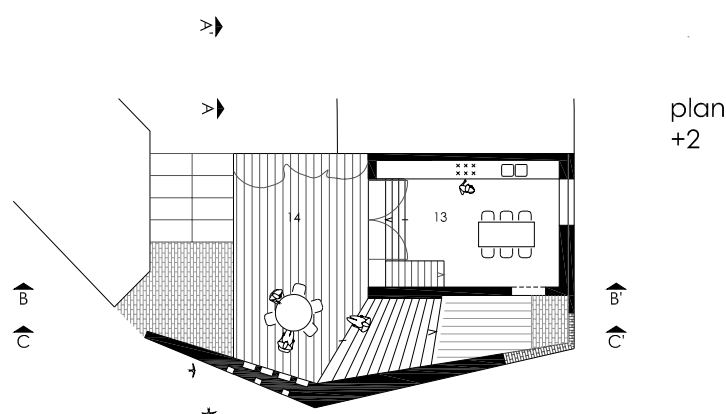
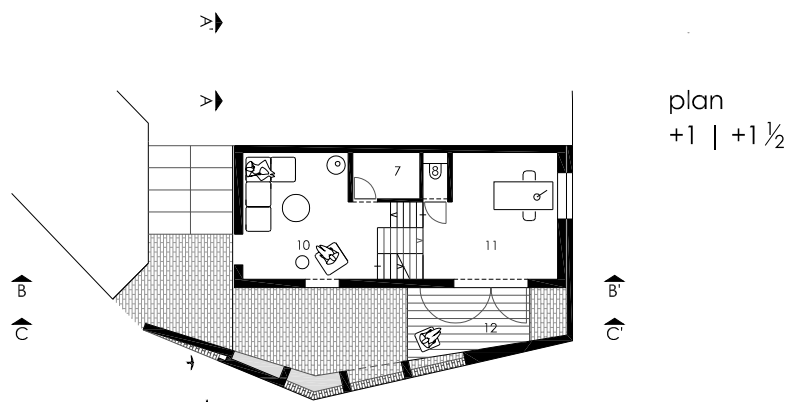
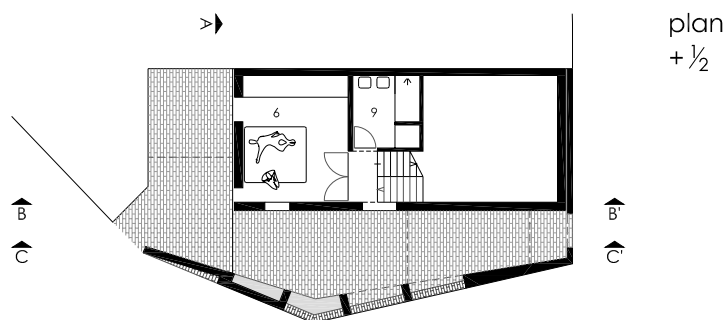
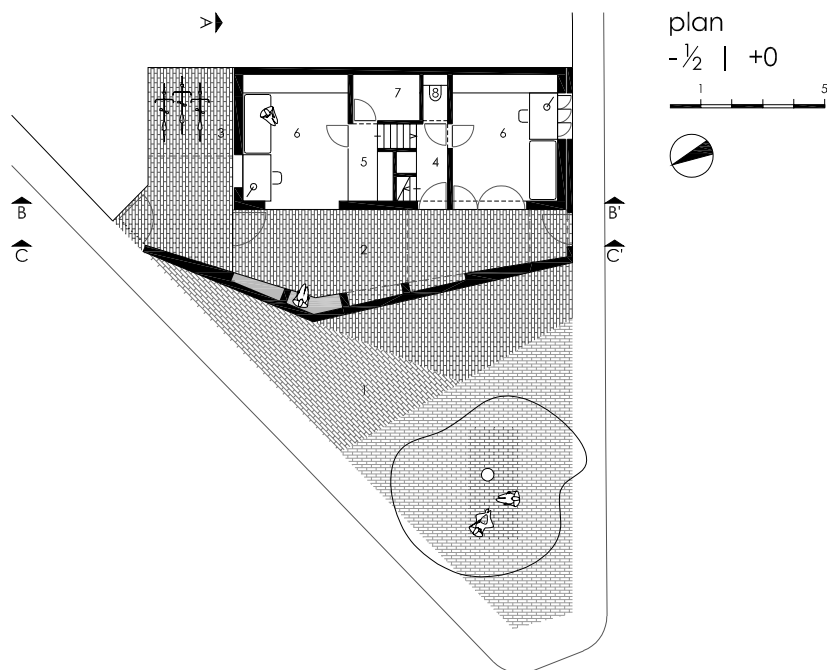

1. square/floe
>brickwork scale/cliff,
with brickwork recessions<
2. wintergarden
3. bicycle storage
4. hall
5. nighthall
6. sleeping room
7. storage
8. toilet
9. bathing room
10. living room
11. studiolo
12. winter terrace
13. kitchen
14. terrace room
15. roof terrace



snede CC'

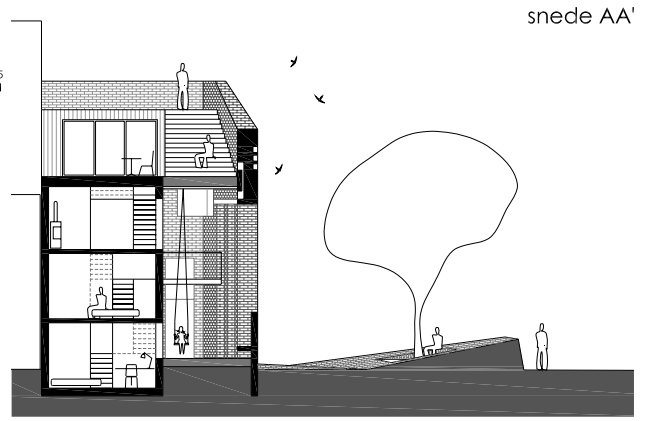

snede AA'

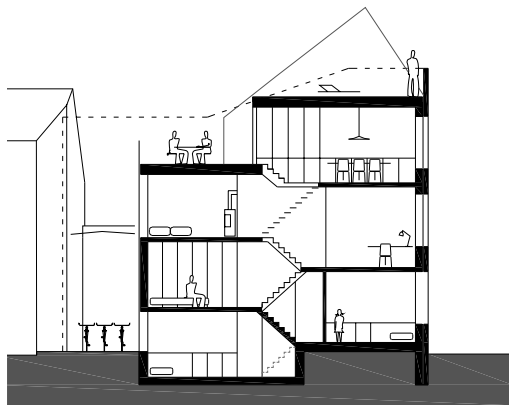

snede BB'



In our design, a small house functions as a core. Around it another house is materialized through the (dis)placement of a largely freestanding wall—a brickwork scale with a sculptural presence. It is this brickwork scale, its design and how it is executed, that I want to linger on and venture from in the following sections. The highest sections of that scale are held in place by a landscape of terraces that evolve spatially around the highest parts of the core house. While one terrace frames the city, the other is enclosed as a room and oriented inwards. These are three of the main elements that in their inextricability constitute the house, each discussed further in this section: first, the core house; second, the sculptural brickwork scale; third, the rooftop landscape. In what follows, I will emphasize the house's outer brickwork scale, which makes an edge to the house as well as (and this is important) providing a border zone of intense interaction with the house's urban surroundings and the variety of actors present in it.

Brickwork walls are fascinating architectural constructions. They seem to be extremely evident, simple, and straightforward. As such, they occupy the outer margins of the spaces one daily encounters and imagines. They are the backdrops of daily life (especially in a Belgian context). Their tectonic presence can be massive or subtle, their impact mute but forceful. But they are anything but evident. It is in how they are deployed that encounters happen, experiences are born, and sense is made.

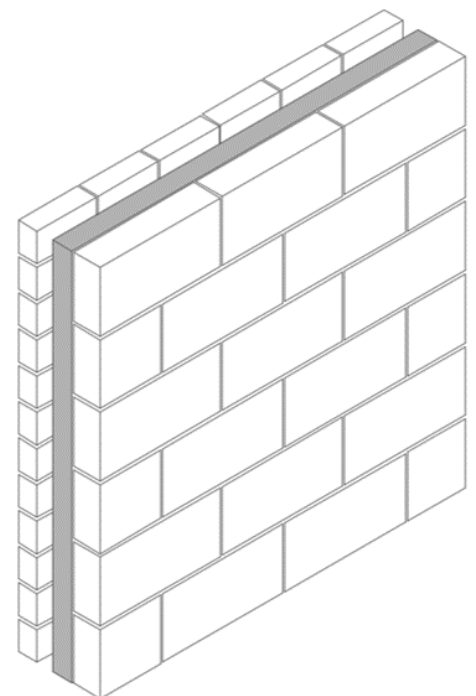

Figure 2.15: Scheme of a traditional cavity wall. Drawing: Johan Liekens.

In our design, we became fascinated by performing an act of displacement. We saw displacing the wall as a necessary condition and strategy for enabling the house to graft onto that bustling urban corner, setting up various kinds of agency. The idea of an act of displacement has to be clarified. Traditionally, cavity walls consist of two parallel planar skins separated by a hollow space. The skins are commonly made of masonry—bricks or blocks. Each unit of masonry has its specific and separate performance, as does the cavity. Venturing from the traditional cavity wall, we experimented with the wall’s latitudinal stretching. The cavity in the design develops from a merely technical element into a typological one. From a technical perspective, the cavity space has an essential insulating role to play, both acoustically and thermally. It makes the site atmospherically inhabitable, so to speak. I refer here to the aforementioned extreme conditions of the house’s surroundings. The habitability afforded by the cavity space moves beyond the technical, however, expanding the notion of an atmospheric inhabitability. The cavity space is itself developed as a habitable space that expands the core house. It functions as a buffer that affords all kinds of activities, including those activities for which space is usually lacking in urban houses. It allows the city to gradually seep in and it allows the core house to extend to some degree into the urban environment. We proposed to think of that interstitial space as a winter garden, a space for a temporary sojourn and possibly some urban gardening, but moreover we imagined it to be a place for aimless leisure time, a space characterized by play, joy, and experimentation. A drawing accompanying our entry proposed a hammock chair suspended from a long rope. When at rest, staring down at one’s feet, the weight at the end of a pendulum, would one detect the earth’s rotation?



Figure 2.15: Interior sketch of the winter garden. Drawing: Johan Liekens.

Figure 2.16: Unfolded model of the Walled House as it was designed showing the brickwork cliff (left), the winter garden (center), and the core house (right). Model: Johan Liekens.

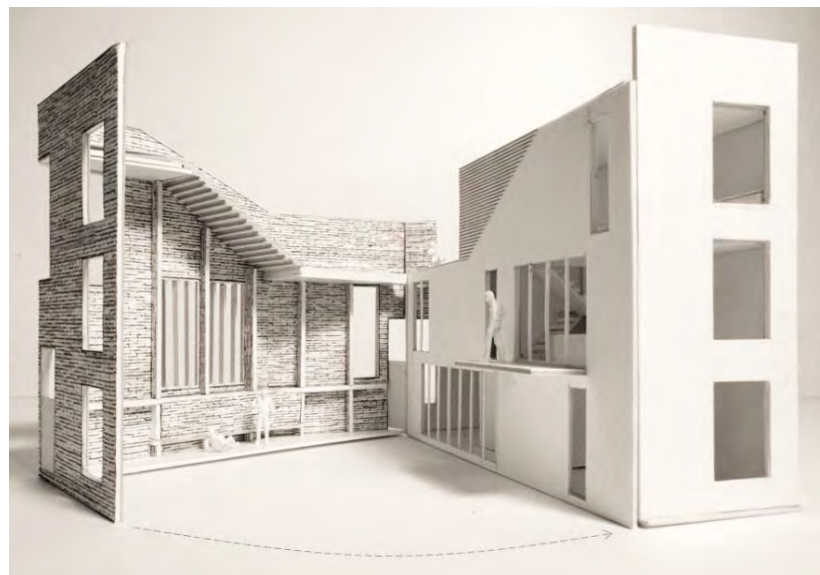

In Belgium there is currently an intensifying debate on the possibility of a so-called *betonstop*, a call to halt further covering of the soil and landscape with concrete and, beyond that, a call to end the all-devouring consumption of the scarce open space remaining in the Belgian landscape, with a 2040 deadline. In an article, the Belgian architecture critic Koen Van Synghel referred

to the Walled House as visionary in this context. Van Synghel enumerates a variety of reasons why people prefer a life away from the city: a connection to the earth and the seasons; the possibility of a garden and a life with fellow creatures; some space to move—to wander, tinker, and fool around. All of these activities connect to real everyday desires that, according to Van Synghel, are in no way to be associated with a mere nostalgic reflex. Rather, it is exactly this kind of activities that grant the urban house what he calls a “naturalness of dwelling,” a naturalness that urban housing typologies have lost and thus lack (Van Synghel 2016). The Walled House’s layout enables a winter garden as a free space that expands the core house for a variety of activities, which can be seen as smuggling some of that naturalness back into the urban dwelling typology. In a conversation with the critic, the owners mentioned that the design of the house, as a model of urban living, indeed convinced them to move from the countryside to the city, something they had previously seen as impossible for them. According to Van Synghel, the house is generous in the strategic positioning of its windows, in the working of its terraces, and in the creation of an interstitial space, a space that is both inside and outside. He states that the Walled House proves that the city is still *makeable* even in an era where the scarce remaining open space cannot be further colonized, and that it can be done without depriving the citizen of the naturalness of living. Following Van Synghel, the Walled House thus functions as a model that affects people and the way they think about and live in the city. Thus it functions as a material artifact that has encouraged one family to think differently, and it can probably encourage more to do so. This encouragement to make people think and act differently can be seen as an example of the kind of agency identified earlier in the goals of SOG’s Urban Lots program.

The functioning of the Walled House as an innovating model, as suggested by Van Synghel, can be broadened by showing how the building is materialized and articulated and how these materializations and articulations enable a complex and dimensional construct to come into being, allowing a multitude of different experiences, uses, and occupations. In what follows, the different composing elements of the house, their functions and atmospheres, will be discussed separately, while in reality they are inextricably intertwined. From the intimate core house one ventures out gradually through the playful winter garden and into the hectic public sphere, where a variety of other activities are enabled. It is a house in a garden in a public square—a house in a house in a house, so to speak.

* *the intimate core house*

The core house is a modest, compact, and logical volume in several senses. First, it is conceived as the most essential inner membrane within which intimate life can both withdraw and unfold—where it can find its unique personal expression. Second, it is modest, compact, and logical in an economic sense, keeping the house within financial reach of SOG’s target group. The orthogonal core volume is constructed using elementary

techniques and standardized materials, making it fast and cheap to build. A central volume within the core links the different floors together. While it structures the main spaces that make up each floor, it does not separate them. This central volume houses the service functions and is in turn served by a large mechanical chase that allows the house to shift its functions over time. There is a strong focus on ecological considerations. Accordingly, the solar orientation is studied in detail. The sections of the house destined for daytime living are oriented to the south and west, enjoying the natural progression of the sun. Thermal losses are reduced to a minimum by the compactness of the core house, its nestling against the neighboring houses to the east, and the winter garden to the west, both functioning as buffers. The winter garden captures the warmth of the sun in winter through strategically positioned window openings in the outer scale. The window opening high in the southwest corner of the winter garden, spanning across the facade's corner, not only adds to the sculptural presence of the brickwork façade, it coincides with the ideal position for capturing the sun's rays. The preheated air thus amassed is used for ventilating the core house. In summer, the winter garden's chimney-like form allows the warmth to be naturally ventilated from the house during the daytime, while at night it allows a natural cooling of the house. In these processes, the detailing and positioning of the windows in both core and winter garden are vital. The materials of the house are carefully selected with regard to durability as well. Due to its specific construction, the house easily attains the technical label of low-energy housing.

Combining economic modesty with the idea of creating a core in which life can retreat and unfold, the volume is materialized as a background. It is a canvas that allows life to assume a central role. Due to the quasi-freestanding brickwork scale that outlines the winter garden on the west side of the core, and due to the nestling of the core directly against the neighboring buildings to the east, the walls of the core are relieved of some requirements normally imposed on exterior walls, such as waterproofing. This enables the core to be a basic construction made with large insulating blocks. At the same time, the enveloping brickwork scale is relieved of the requirement of providing thermal insulation, allowing it to be just a massive sculptural slab of brickwork that expresses another kind of buffering.

The core's interior finishes are elementary. Walls and ceilings are rendered. A bright white volume materializes, the only notable details of which are the wooden floors, the white metal handrails, and the heavy wooden frames of the windows and doors that open at different levels into the winter garden. These wooden frames protrude slightly from the exterior surface of the core volume so as to delicately express their presence and underscore the protrusion of the core into the cavity of the winter garden. At the same time, this way of detailing eases the making of connections between rendered sections and window frames. Each technical expression is doubled by the expression of an architectural intention and vice versa.

In the initial design, the positioning of the frames in the wall

facing the winter garden related to a grid, with the opening or closing corresponding to different functional schemes. From of these functional schemes, the (then unknown) future resident could make a selection adapted to his or her own particular way of life. Thus, the client is invited into the design project, engaged in laying out the house. There is the possibility of occupying the house in a variety of ways. One can situate family life in close relation to the rooftop terraces, as is the case now, thus situating the sleeping quarters in direct relation to the winter garden. However, the house easily affords other constellations of family life as well.

The materialization and characteristics of the window and door frames are different depending on their position in the core. As I've mentioned, wooden frames open up into the winter garden, with glazing of standard acoustical characteristics. Where the walls of the core converge with the brickwork scale, aluminum frames with a high-performance acoustical glazing are used. This is the case in the south facade, where the core house relates directly to its urban surroundings. In contrast, the generous winter garden windows scooped out from the brickwork scale are filled in with slender aluminum frames and glazing used in industrial aluminum greenhouses. The glazing applied here is an economic, technically undemanding type of glazing. Taking advantage of affordable greenhouse techniques suggests connotations with aspects of urban gardening. Again, a series of environments is articulated that can be separated or combined. There is the quietude of the core; the time of play unfolding in the winter garden in which one can hear the city's echoes; the vivid anxiety of the public square and urban surroundings; and there are the numerous combinations of all these that can be made.

The bright white core house, developed as a canvas with contrasting details kept to a minimum, establishes an opposite to an urban context characterized by the flamboyant overload of heterogeneous elements described earlier. Contemplating the city from within the core house, one's gaze is continuously framed by a combination of window openings: those of the core's walls and those scooped from the enveloping brickwork scale. From the core, one sees the muted city mediated, or decides to invite the outside world and its echoes inside. At the same time, the duplication of window openings hampers an all-too-direct view into the house.

The window doors that open the house's *studiolo*, a small reading and work room, onto the winter garden give access to a free-floating balcony, from which one can witness the playtime and experimentation unfolding in the winter garden. From the balcony, one can observe the vivid street life through large windows. Thus, as is the case in the winter garden, the living area itself is temporarily expanded toward the house's borders.

The core volume is, as noted, a subtle canvas on which life itself can come to the fore. However, the sobriety of the core was disturbed in the effective realization of the house. Due to the addition of an extra room, the northern half of the core house sunk half a level. A constellation of split levels resulted from this, giving way to a more expressive spatial development of the core house, counteracting somewhat the simplicity we originally had in

Figure 2.17: *The Boiled Egg Scheme kept in our kitchen. Source: unknown.*



mind. In addition, a new vertical circulation with three zones for staircases and stairwells was devised, augmenting the openness of the staircases in the upper parts of the building. This spatial opening up is strengthened further by the lightness and transparency of the stairs themselves and by the light metal railings that allow one to glance more easily from one space to the other, bringing into experience the porous construct the Walled House is or intended to be.

Adding to Van Syngel's identification of the Walled House as a visionary model, the technical and material-economic characteristics of the particular layout of the house can be seen as underpinning the house's agency, as touched upon at the outset of this section. However, the notion of architectural agency we wanted to activate in the Walled House project had another dimension as well.

* *_the enveloping brickwork scale, of cliff and floe*

Our design entry to the architectural competition included the image of an egg we cut in half, medium boiled for four and a half minute, the yolk still dark orange-yellow, moist but dense in the middle, enveloped in the solid egg's double white. All these again contained by the egg's calcic scale, which protects it from outside conditions while at the same time allowing certain outside influences, such as the transmission of the warmth of the hand that holds the egg.

Although this image corresponds to how the house is laid out in a succession of environments from core to periphery—although it connotes with architectural ideas such as buffers, thresholds, and layers—it does not do justice to the dynamics of the envisioned layout. The egg's ultrathin scale does not correspond well to the active and multidimensional role that is played by the brickwork scale enveloping the core of the Walled House as it was designed. The uniform and solidified white(s) fail(s) to emanate the heterogeneous playtime that awaits in the winter garden. It differs substantially from the cavity's function and that of the perforated slabs to stir communications and mediate spatial connections between radically different environments (between public and private). Also, the boiled egg yolk does not do a good job of representing the unfolding of an intimate inner-life.

Thus, I want to focus in on the house here based on another scheme that works in a more spatially dynamic way. One of the particularities of the design brief accompanying the competition stipulated that the design would have to encompass both a private house and a public square. Indeed, on the scheme added to the brief, the lot was divided into a zone for the house and a zone for a remaining public space, literally separated by a thin red line.

The contending designers were urged to think about that public space, and moreover they were invited to think about the position of the red dividing line. Dimensioning and giving sense to, or rather allowing someone else to give sense to, that public space and that dividing line between house and city became itself a leitmotiv in our design work. During the design a scheme figured in our minds dealing with the spatial negotiation the



Figure 2.18: *Excerpt from the design brief: site plan with suggestion for a zone for a private house (blue), a zone for a public square (green), and a red non-dimensional line separating both. In the design, the negotiation of that line and its dimensions became a leitmotiv.*

house deployed. Indeed, there was a long period in which the enveloping brickwork scale was negotiating its position and functioning in the overall terrain. The scheme also prefigured the spatial negotiation that would effectively be deployed on site once the house was built and subsequently occupied from all sides. At least this is how we thought it would be. The (model of the) scheme, which is included here, connects in its simplicity to the architectural idea already hinted at of a typical cavity wall being stretched apart and displaced spatially.

The model is made up of two rubber bands, a few pins, and a sharp cutter. With a first rubber band, a simple orthogonal area is demarcated on the site. This demarcation separates an area for the compact core house on its inside from an area that is conceived as a public square on its outside. This first, inner rubber band is subsequently doubled by a second thicker one, rendering more complex the dimension of the dividing line. Stretching this outer band negotiates a new interstitial territory in the public square that was just established. A new division arises, separating an interstitial space between the core house and the public square. This new interstitial zone is seen as a buffer between the core house and the public square, while at the same time constituting an expansion of both. The status of this interstitial zone we conceived as being not fully fixed or clear, but remaining somewhat ambiguous. This ambiguous status is subsequently fortified by a next operation. Where the outer band borders the public square it is cut lengthwise. One part of the cut band is stretched back into the interstitial space, splitting that space further into an inner and an outer section. A sequence of spaces and environments is thus deployed: the intimate core, the inner half-wall, an interior square we called the winter garden, the outer half-wall, the public square, and a series of public niches or alcoves folding back into the winter garden. The outer brickwork scale of the house, represented by the thick outer band, thus negotiates its position with regard to the site and to both what is situated on its inside (an intimate dwelling) as to what is situated on its outside (a passionate engagement in urban public life). The construct in its complexity started breathing a sense of porosity (I refer here to the Latin *complicare*, which suggests a folding activity, amassing space in complex ways). In the competition brief, a building alignment was schematically proposed, a non-dimensional thin red line dividing the lot into a parcel for the house and a parcel destined to be a public square. However, from the outset we decided to deviate and turn the border into a complex, ambiguous, and compromising space and adventure rather than a strict dividing line.

The spatial and functional negotiation we proposed is twofold. While the brickwork scale moves outwards onto the site, reducing the area of the public square and affording the creation of an interstitial winter garden, a large horizontal section at the base of the scale moves inwards. The convex form of the scale is thus doubled by the concave movement of some public niches. While our project is built from firm and solid materials, with a passion for the materiality of brickwork, I prefer to think here about the layout more organically—as a set of resonating membranes that is able to contain, to combine and separate, and

Figure 2.19: The rubber band scheme of the Walled House, negotiating between the house and the urban landscape. Model: Johan Liekens.

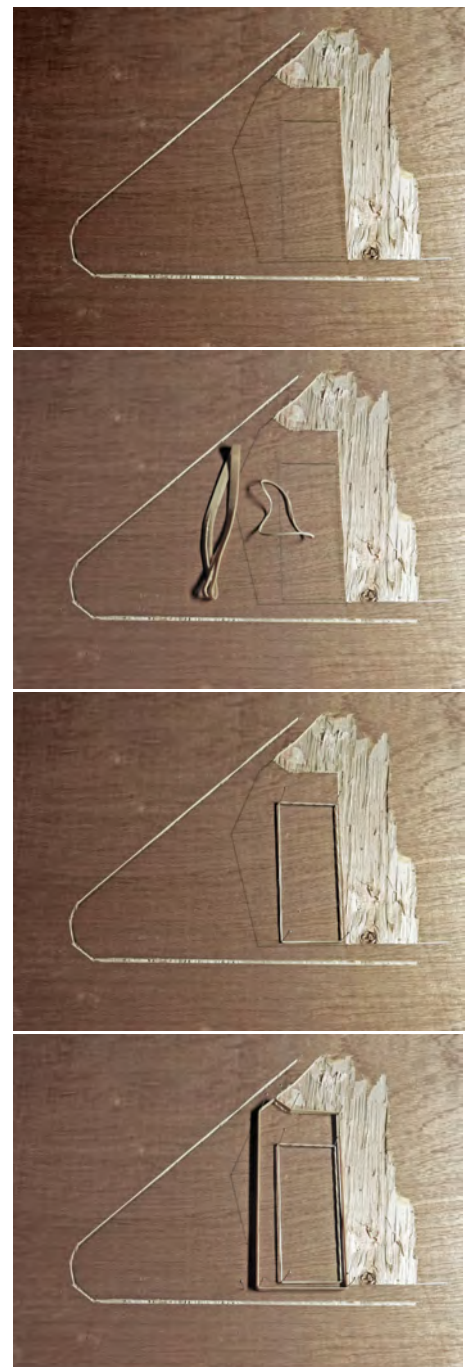

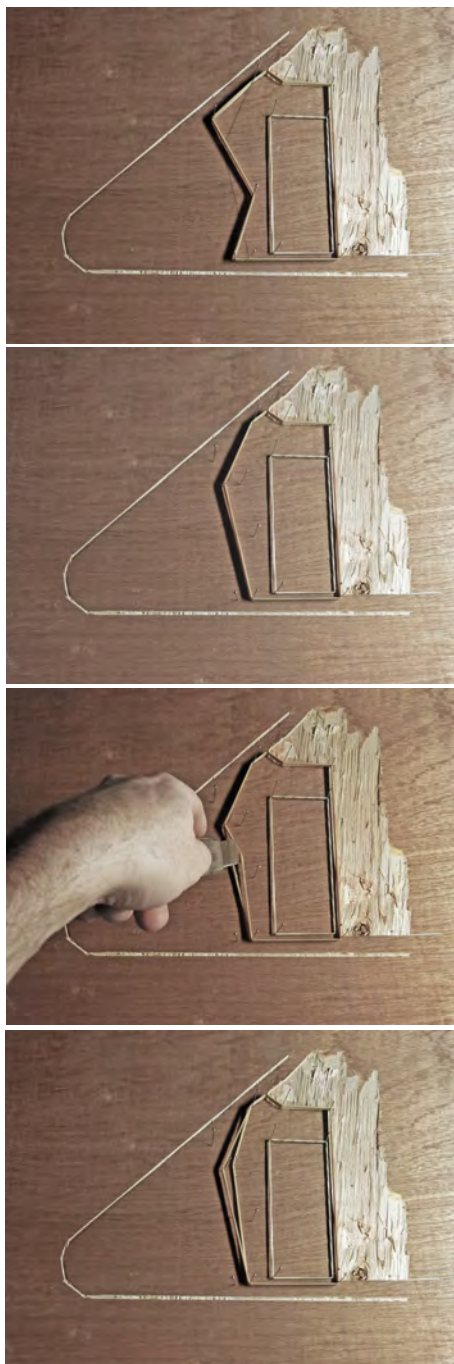

also able to deform, to swell and to dwindle. The urban environment makes an imprint on and in the house while the house executes an incursion into the urban landscape.

In the house as executed, the sensation of the brick wall being displaced, being decoupled from the inner face of the cavity wall, is strengthened by the articulation of the second entrance on the north side of the lot. A narrow vertical breach now separates the brickwork scale from the neighboring building. On a practical level, the second entrance expands the flexibility of the house. Moving through the breach, a patio harbors a family of bicycles (Fig. 2.20).

And yet, returning to the scheme as laid out in pins and rubber bands, the model does not satisfy like the real thing. It does not capture the material and atmospheric experience the house-high winter garden offers, nor for the possibilities offered to the inhabitant at each of the floors and spheres of the house. The model does not demonstrate the numerous possibilities for contingent events and uses offered to the passer-by, nor does it address the material substantiation and articulation of the sculptural, multidimensional scale that negotiates (the uses of) house and square. Essential to the design and largely missed by the model is the fact that the brickwork scale described above as a quasi-freestanding vertical construction is in fact only part of a larger continuous, all-encompassing architectural body. In that overall body, vertical brickwork wall sections are continued with something that is best described as these sections' horizontal shadow projected onto public space. What we envisaged emerging is one massive slab of masonry, like a grabbing hand reaching outwards, with color tones spanning from yellow to green, combining in its materialization a strong vertical presence (a brickwork cliff, so to speak, that spans the west and north facades) with a strong horizontal presence (a brickwork floe so to speak, materializing the public square at the base of the cliff). Hence, in what follows I will refer to the cliff when talking about the vertical sections of the overall brickwork scale and to the floe when talking about the public square that is an intrinsic part of that overall scale.

In the fold between cliff and floe, as I've said, public niches are nestled, their status not entirely clear (see photographs of the cardboard model). The niches hesitate between being an evident functional asset to the public square (some public benches) and being the space affording a more ambiguous occupation and retreat, cut off to some degree from the general surveillance that often seems to govern public space. These niches were considered a first outline to be further developed en route, equipping them with a certain degree of estrangement and thus heightening their ambiguous potential. Here, in Till's words, architecture is considered to be "about making space, but also about leaving space for interpretation" (Till 2009, p. 108).

In order to provide the requisite rigidity for resisting wind loads, the cliff evolves at a rhythm of vertical lines from a flat brickwork slab into brick pilasters that protrude into the winter garden. This materialization is paired with the angular development of the cliff's wall sections. In the outside scale of the cliff, these shifting angles constitute vertical seams accentuated by

indented masonry. Some of the winter garden windows are stretched across these angles to augment the influx of light at certain places, while augmenting at the same time the overall sculptural expression and the suggestion of permeability in the wall. The angles and protruding pilasters provide the west facade with the depth needed to give the wall its stability. In parallel to this technical constraint, the depth created suggests that the cliff is a more-dimensional construct, able to contain life, waiting to be lived. Paired with the angular shifting of the facade, these pilasters create rhythm, increasing the cliff's spatial, functional, and atmospheric possibilities. In combination with the flat wall sections, they allow for objects to be shown or stored, for firewood to be stacked, and, most importantly, for bodies to be seated on one side of the wall or the other, possibly revealing fragments to one another. The pilasters help carry the concrete seating slabs on both the interior and the exterior side of the cliff. They help carry the concrete headers over the niches and the beams that make possible the generous window openings of the winter garden. The vertical rhythm of brickwork pilasters and angular seams here is doubled by a secondary rhythm of horizontal concrete slabs and beams. Through their materiality and articulation, these pilasters, angles, slabs, and beams allow the light to play on and in the scale of the brickwork cliff. They cast shadows into the niches or accumulate the sun's warmth, attracting the heated or chilled body of its passer-by. The pilasters articulate a segmentation of the public niche into several public niches, making less immediate their proper function. Overall, the brick cliff allows for a difference of occupations, whether intended or contingent. In this, the cliff is imitated by its horizontal shadow, the brickwork floe that cuts out a public space from its surroundings. Moving away from the brick cliff, the floe's sides are tilted at slight but increasing angles, culminating in a somewhat protective mass at the western-most part of the public square and also establishing two entry zones in the fold with the brick façade. One moves naturally from one street to the other in close proximity to the house's facade, cutting of the sharp corner of the lot. As a consequence of the square's slope, one has the impression of slightly sinking into the square when entering it. From the square's edges, oriented away from the hectic surroundings, one faces the cliff, its uses and occupations. At least, this was the intention.



Figure 2.20: Narrow vertical breach separating the brickwork scale from the neighboring building. Photograph: Stijn Bollaert.

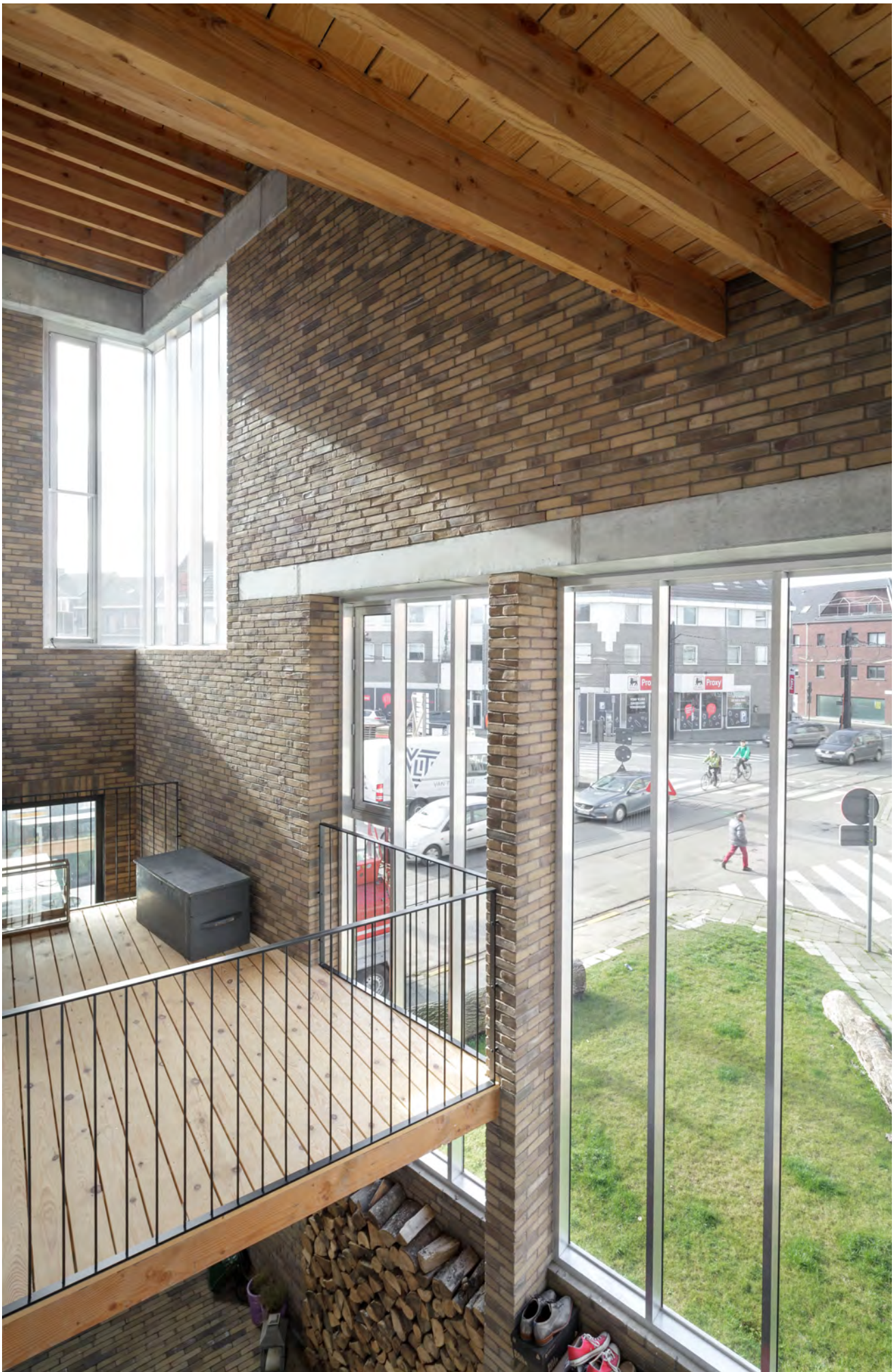



Figure 2.21-22: The winter garden as a buffer and a passionate mediator between intimacy and the bustling urban environment. Photograph: Stijn Bollaert.



Figure 2.23: The winter garden roof dilating the cavity between inner and outer wall faces and also functioning as a support for the rooftop staircase. Photograph: Koen Matthys



Figure 2.24: View through the winter garden over its bustling urban surroundings. Photograph: Stijn Bollaert.

* *_the rooftop landscape*

The brick cliff is held in position through the deployment of a landscape of roof terraces that wrap around the highest parts of the core volume, each radiating a different atmosphere. The lowest terrace is itself walled, intimate, and oriented inwards. We considered it to be an outdoor room screened off from the urban surroundings. The stairs that lead from one terrace to the other are spacious. They afford one to move across or take a seat. They constitute another stage. Climbing the stairs, rising from the enveloping scale, one reaches the higher terrace, with its dramatic view of the surrounding urban environment: a vantage point on the phenomenon that is the city. The different levels of the terraced roof and their unification by means of the spacious stairs likewise constitute the ceiling of the winter garden. Their structure of wooden beams and planking is left exposed, adding to the basic but rich material atmosphere of the winter garden. On the interior, the ascending movement resonates with the angular, convex movement of the brickwork cliff, adding to the overall sculptural expression of the winter garden. Viewed from its surroundings, this movement establishes a gradual transition from one street to the other. The brickwork scale, encompassing both cliff and floe, establishes a visual, functional, and atmospheric accent in its surroundings, while at the same time attuning to them.

Figure 2.25: The winter garden, with alternating vertical and horizontal rhythms, with inner facade and outer greenhouse facade, with studiolo and interior terrace opening onto the winter garden and city. Photograph: Stijn Bollaert.





Figure 2.26-28: The rooftop landscape, the upper terrace, and looking down from it, the intimate space of the lower terrace-room. Photograph: Stijn Bollaert.

* *the two versions of the Walled House*

The sections above touched upon some ideas about the Walled House's agency. I suggested that an idea of architectural agency was already present in the organization of the Urban Lots program—in its deployment of strategies aiming to change the existing socio-spatial urban fabric through acupuncture-like architectural interventions. I discussed another idea of architectural agency being present, drawing on Van Synghe's observations about the Walled House. He identified it as a model that could convince people to think differently about the urban environment and even inspire them to live in the city, thus avoiding further development of the scarce open space remaining in the contemporary Belgian landscape. I described how the Walled House is materialized and articulated and how this materialization and articulation are closely related to ecological concerns, while at the same time enabling a complex and dimensional construct to come into being, offering a multitude of different experiences, uses, and occupations. In what follows, a transition is made from the house as it was designed to the house as it was built. In my understanding, these are two radically different versions of the Walled House. The main difference is documented in the isometric drawings made after the house's completion, which are included here. The essential difference,



Figure 2.29: Cliff and floe affected by tidal waves of occupation. Drawing: Johan Liekens.





Figure 2.30: Cliff and floe of the Walled House as it was designed, comprising in its architectural enveloping body public niches and a public square. View from the perspective of the public surroundings (left) and from the interior (right). Drawings: Johan Liekens.

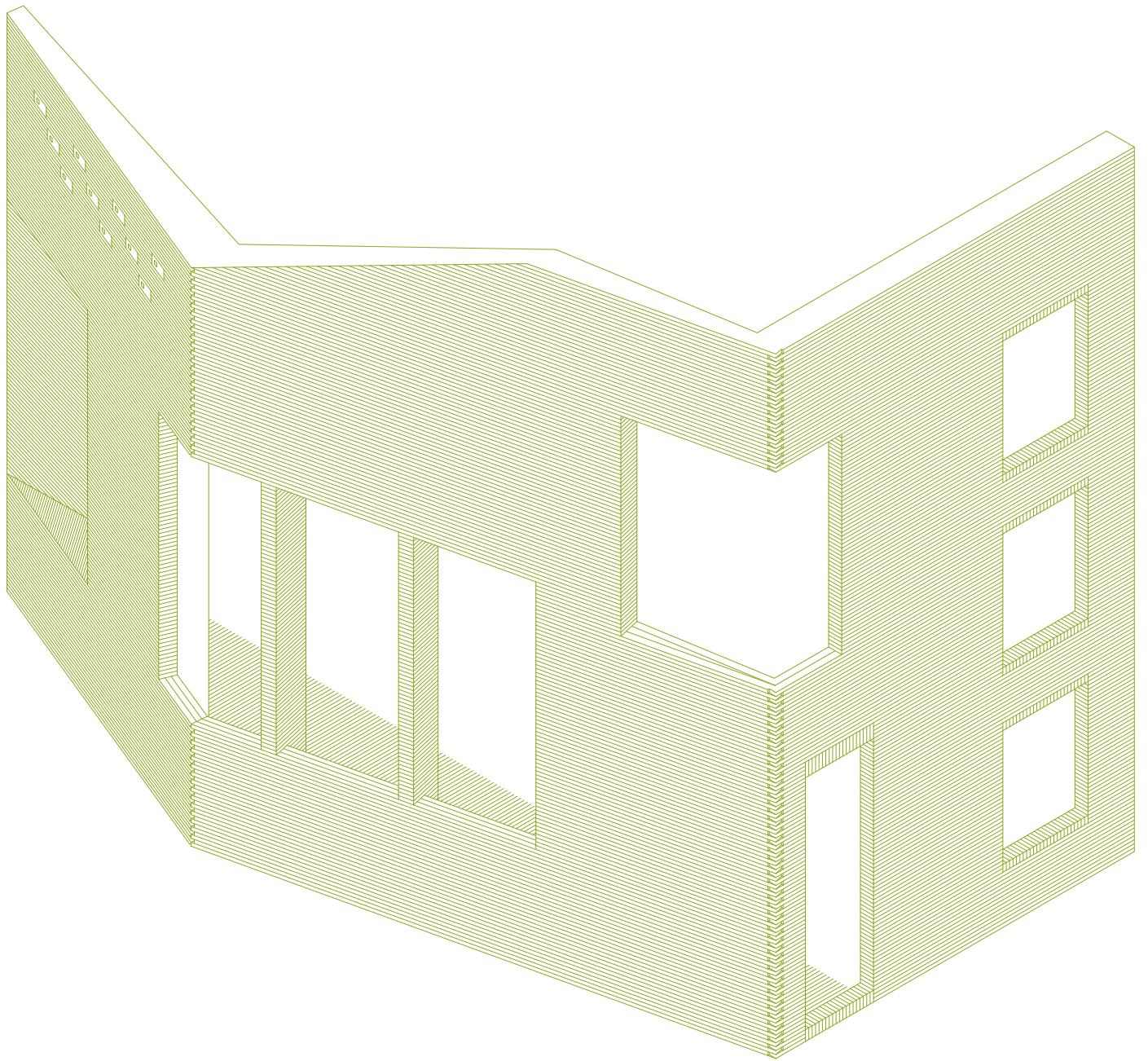



Figure 2.31: Cliff and floe of the walled house as it was built, public niches and a public square erased. View from the perspective of the public surroundings (left) and from the interior (right). Drawings: Johan Liekens.

though neglected in the various publications of the Walled House, relates in a fundamental way to the notion of architectural agency, and with it to architecture's critical, political, and ethical capacities.

* *_the house that was built*

As is always the case, the designed house differs from the built one. Some aspects were further developed in the realized building, while others were abandoned. It is only logical that the initial design be renegotiated with the inhabitants of the future house and with other stakeholders. The construction of the building and spatial presence of the finished construction profoundly touched both the inhabitants and the architects. We all enjoyed witnessing the generosity-in-action, the concert between the core house and the enveloping brickwork scale as it mediated between different atmospheres and the rooftop landscape. The functioning of the house coincided with the clients' ideas and expectations and made them forget their doubts when moving from a pastoral life in the countryside to this intense urban corner. The project was picked up publicly without an initiative from our side: it was part of the *Day/Festival of Architecture 2015* organized by the Flemish Institute of Architecture (VAi) and was included in the institute's 2016 *Yearbook of Architecture in Flanders*. As already mentioned, in some publications the house itself was seen as an agent for thinking differently about urban living.

And yet, I want to linger on some of the project's unrealized potential, which could have sharpened the Walled House's architectural agency. I even want to speak of this unrealized potential as a failure. But that failure is both enlightening and demonstrative: it connects to the research narrative I am in the midst of setting out, showing that radically different views on the construction of the urban environment have been involved in the making of this building, shifting its orientation and with it also its affordances and agency.

Forgotten intentions and failures are part and parcel of any project. However, they are seldom communicated, and almost never do they leave traces or gain a perceptible material expression. The Walled House project can be said to have been born from an idea of productive conflict. One can think of the initial spatial conflict over terrain and territory executed by the brickwork scale over the lot, of the nestling of an intimate atmosphere in otherwise hectic urban surroundings, of an ambiguity between the two, with public alcoves receding into the façade and private sphere of the house. I think here of Wolfgang Meisenheimer's identification of what he calls the hollow "crust" of a building, which he considers primarily to be a "zone of contradiction," that is uncontrollable, a "conversational zone," a space "where qualities of experience tip over into each other or out of each other" (Meisenheimer 1984, p. 103). Here, there is an "openness of the decisions to be taken," which makes that crust-border "the most eloquent backdrop of the architectonic stage" (Meisenheimer 1984, p. 108). We intentionally crafted footholds into the flesh of the house for certain productive conflicts,



Figure 2.32-33: House and square, the Walled House standing somewhat autonomous today in its context. Photograph: Stijn Bollaert.



for conversation and uncontrollable contradiction, awaiting their poetic production, or poesis. And yet these germinal articulations and subsequent potential became preemptively erased and muted as if they were optional features of the house to be selected or cut: neither the public niches nor the public floe were realized. Hence, the poetic (and arguably micro-political) potential of a variety of occupations (possibly conflictual ones) afforded in the seam between cliff and floe and the tension between different but connecting territories never came about. Equally, the brickwork scale did not meet our intention to make it inhabited throughout the full extent of its body, our intention to make it a primer for a multitude of expressions, projections, appropriations, and occupations fueled by the desires present in the neighborhood. In the transition from design to occupancy, the Walled House encountered a more defensive stance towards the urban environment, which in hindsight often seems to pop up. An irreversible and defensive course was taken, rapidly revealing itself in conversations with the future inhabitants and official city services entrusted with the design and management of public urban space (in this case the floe or square). In the end, it seems that every single piece of the urban environment must be fundamentally controlled space. It still makes us wonder, *what if...?*

Wondering about these *what if* scenarios, about the dynamics of negotiation that could have occurred in the seam between cliff and floe, one might think of what happened in the vicinity of the two aforementioned telephone booths that became agents in the collaboration that unfolded between Sophie Calle and the novelist Paul Auster. Auster challenged Calle with a set of instructions, one of which was to *cultivate* a spot in the city and to make that spot matter. Acting on this instigation, Calle took over two phone booths on a section of sidewalk, a small square so to speak, and started adding objects to the booths. Thus, she interfered and tampered with the site as it was (known). In response, a variety of actors started to act, each of them expressing different interpretations and appropriations through their uses and occupations of the spot (and its alterations). These expressions moved between sympathy and dissent, between joy and concern. The actors claimed the site each in their own ways. Calle reports on some of the conversations that sprouted from the encounters of a variety of actors with the altered booths and the altered site:

“Ill ... people are ill. I can’t believe it, someone is ill, I can’t believe it.”

“What happened there?”

“I don’t know, someone got killed here, maybe.”

“Why don’t you use it?”

“Nah! It’s bad luck.”

“Why?”

“That’s what I think. It’s kinda weird.”

“So why would it be bad luck?”

“I don’t know. It’s someone else’s phone. I don’t want to use it. It’s private property.”

“Oh, so out of respect.”



Figure 2.34-35: Sophie Calle’s phone booths, stocked with props, engaging divergent sets of actors. Photograph taken from the book *Double Game* by Sophie Calle.

“It’s like a waiting room.”

“A waiting room?”

(Calle 2007, p. 246).

By connecting the thoughts mumbled on the site to other visitors, the site itself becomes (re-)negotiated. What is revealed through the spatial agency of the phone booths on the site and their slight alterations are the present yet hidden aspects of the neighborhood, showing how complex and multi-faceted urban spaces really are. Similarly, Teal states that in the creation of what he calls *better* environments, it is particularly important that designers and planners pay close attention to the ways in which people actually interact and participate in the city and how certain environments make this interaction possible (Teal 2009, p. 127).

Another account of what could have happened in the shadows of the Walled House’s brickwork scale as designed is suggested in Philippe Viérin’s article “Corner Stones”, written for the 2016 *Flanders Architectural Review N°12: Tailored Architecture*. In that article, the Walled House serves as a case to discuss the potential of urban corners. Viérin proposes that these are “metaphors for the city”, with “a public role,” where people, constructions, movements, and energies cross one another and form meeting places as spaces of diversity, chance, and interaction. Referring specifically to our walled corner house, Viérin speaks of an “urban beacon,” a point of orientation in multiple senses. On such corners, negotiation happens, such as the negotiation between city, corner, and interior, he stresses. As I have pointed out before, it is the in-habitations of city, corner, and interior that cross one another here, negotiating people’s *belonging to* or *dissenting with*, assisting in that way in the formation of diverse subjectivities and creating new voices to be heard. Viérin refers to Ignacio de Solà-Morales, who ascribes to urban corners a capacity to express the power and energy of the city, its reasons of being (Viérin 2016, p. 51-8; de Solà-Morales, 2004).

In the same article, without prior knowledge of what I have called above a failure of the Walled House, Viérin identifies a risk looming around the corner. In the Walled House, as is the case in other contemporary corner projects he advances, a reversal of usual urban living can be perceived (as a typology). The living spaces are situated adjacent to the roof terraces, while the sleeping quarters are situated in the base of the building volume. As a consequence, in their connection with the street these houses may appear somewhat enclosed, not communicating some aspects of an interior life. In the case of the Walled House, Viérin speaks of a “monumentalized” façade (Viérin 2016, p. 55). He points out that the risk is countered though by means of the double sets of generous window openings spread across the all-encompassing brickwork scale. I would add to this the aspect of the scale’s standing free, opening up interior vistas in that way. However, in my understanding, the perceived problem can be brought back to the unrealized expressions of use and occupation, of material depth and being inhabited, of subtle transmissions between city and interior by an other order of interiors that would have characterized the seam between cliff and floe. Meisenheimer

makes mention in his writings of “interiors of the second order”, which bring nuance and doubt in the transmission between city and interior (Meisenheimer 1984, p. 108). Whether the alcove-like interiors of the Walled House are secondary or not, it is important that they are considered as full-fledged interiors here, full of negotiating potential. They would not have been just neutral public benches.

As already shown, in my conception of architecture I consider the addition of a certain degree of conflictuality to have a productive and *poetic* potential. I use the word *poetics* here in the sense of a micro-political making activity in the urban environment, what Sassen calls an “urban poesis” (Sassen 2006, p. 1), in which the flesh of architecture, its materialization and articulation, becomes co-constitutive in processes of negotiating sense. Passing by the Walled House’s scale, one is invited to use (or abuse) it, thus negotiating the sense of the place and of the encounter in which one has become involved.

In the higher parts of the wall / cliff as constructed, prefabricated concrete bird’s nests are integrated into the masonry. The nests underscore the wall’s intention to be inhabited and its status as a cliff to be colonized and occupied. The cliff of the Walled House grants the birds the height necessary for each leap into the abyss of the urban environment. These fellow creatures are indeed cherished guests colonizing urban cliffs. However, I wish to deplore the failure of another kind of colonization and occupation we conceived as an essential component of the initial design’s agentic capacity: an agency intending to probe the socio-spatial constellation of the urban environment at a local point, awaiting a multitude of occupations and inscriptions stemming from a non-consensual gathering of fellow human creatures. I think of the proper and benevolent neighbor or the group of locals expressing their neighborhood at the Walled House serving as one of this neighborhood’s gates or beacons, but also the passer-by alien to the situation, such as the man found poking a fire or the two children taking shelter in the locked hull of the *Public House*, each of these venturing from and giving expression to a different set of desires. The Walled House as designed thus conceives of the urban environment as a breeding ground for (social) experimentation, where issues of the individual challenge issues of the common(-sense). It aimed to offer, through minimal articulations, footholds for events to graft and unfold, for making present instances of the urban environment that are not yet articulated or fully exposed. The negotiation here is not just spatial but social as well. The house gives and takes. Moreover, we devised it to provoke territorializations, de-territorializations, and re-territorializations.

The jury for the architectural competition in its comments favored the generous gesture the designed house made, mentioning that “the house offers a hand to the public domain, so to speak,” that “it expresses quite elegantly that it will enter into a dialogue with the neighborhood” (excerpt from the jury statement). This desire to communicate was considered a key aspect of the design. Browsing through the jury statements for the other competition entries, the very gesture our design made and

the elegance and fortitude of the gesture's development was seen as distinguishing for our entry. In the urban reality, this communication is not unproblematic, of course, and exactly because of this it carries the potential for a certain poetic production of events and uses that is not to be foreseen or controlled, yet inextricably part of the complex realm of the urban environment.

It is remarkable how easily these acknowledgments of the house's generosity were forgotten. As noted, neither the niches recessed into the cliff nor the brickwork floe were executed. As built, the house has become to a certain extent autonomous, having lost an important aspect of its relational potential and agency. It is far less a mediating construct than intended. What the designed house aimed for was a leap into the abyss of the unforeseen, the unpredictable and uncontrollable, connecting more to the sheer messiness of the everyday urban environment. However, there seems to exist a general loathing of these kinds of events, which offer uses but do not eradicate so-called deviant abuses, seeing these instead as potentially productive. In the end, the urban facade we conceived plainly became private property of the house, and what was intended to be an intense border zone dwindled back into the thin red dividing line. The brickwork square became a soggy lawn, and in it, pending the arrival of standard street furniture, lies a pair of chestnut trees to sit on, harvested from other lanes in the city, victims of a disease that is decimating the city's tree population. The enveloping, mediating brickwork scale we had envisioned has lost half its potential, I would argue, giving way to an unarticulated and little used square, too unobtrusively connected to the surrounding streets and sidewalks, reeking of rot. An autonomous house now rises above it. I've included here the professionally taken photographs of the project to portray the Walled House as built. The photographs reveal a certain absence that relates to the above narrative. This absence has led me to return to the drawing board.

What is at stake here, one could argue, is architecture's *political* agency in the urban environment. The question is whether architecture is conceived merely as a problem-solving activity, formally translating prescribed programs and assigning things, bodies, functions, activities to their proper places, or whether architecture also sets up problems and instigates negotiations on worlds that are too easily taken for granted. In the latter conception, through its material presence architecture invites a variety of interpretations and occupations, unforeseen encounters, and subsequently negotiations. In the case of the Walled House, that is a negotiation on the status and potential of the lived urban wall. The question is whether it separates or connects, whether it is an owned and stable construct or a tidal line of occupations—swelling, then receding, only to swell once more.

The house that was built and the house that was designed are two radically different versions of the Walled House. They each tell a different story about the inscription of the intimate into the socio-spatial milieu of the urban environment, about (non-) connection and (non-)communication. One tells a story about

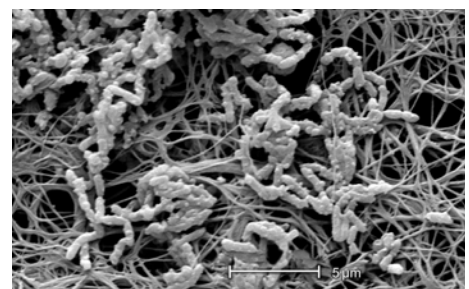
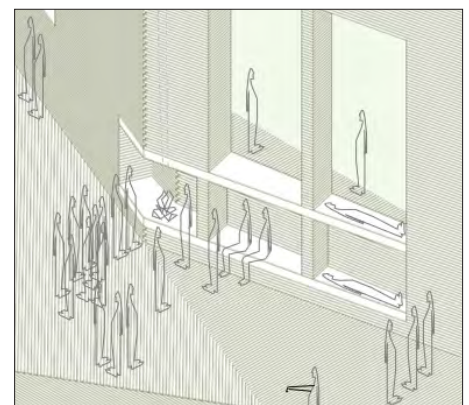

Figures 2.36-37: A biofilm growing into the porosities of and onto an existing constructions, such as the Walled House, hinting at a material as well as social wearing and weathering. Photograph retrieved from: <http://theconversation.com/unlocking-the-secrets-of-bacterial-biofilms>; Drawing: Johan Liekens.



Figure 2.38-39: *Also a citizen, Zakkenman (the man of bags) occupying all kinds of small spaces in the city, establishing acts of social wearing and weathering. Photograph: De Persgroep, courtesy of RV; Johan Liekens.*

risks and how to meticulously avoid them—a story that almost always seems to pop up and even becomes associated with good urban architecture. (The literal story: no more peeing corners! The more essential version: no more spots that allow for an ambiguous reading.) The other version of the house acknowledges urbanity as a vivid and messy reality, telling a story of productive conflicts and negotiations.

Rancièrè’s aforementioned distinction between the policing and the political comes to mind here. Architecture that is seen as a policing practice in public space avoids allowing conflict to play out or even take place in public space. Architecture as a micro-political activity, by contrast, invites exactly such negotiations. Architecture as a policing activity maintains the proper in its assigned place. It guides or dictates how public space should be used in a proper way, defining through architectural articulations what the proper place of each object, body and action is.

Conversely, architecture as a political practice invites the absent to find expression through specific appropriations, both anticipated and unforeseen, and the processes of negotiation that sprout from their connecting and colliding. While architecture as a policing activity affirms, a political architecture invites new socio-spatial constructions to come into being, or at least it enables their temporal articulation. Architecture as a political activity thus reveals the construction (a re-calibrating in progress) that the urban environment always is. This kind of political, according to Rancièrè, is “re-figuring space” and re-distributing the “sensible,” allowing for “the appearance of the subject” (Rancièrè 2010, p. 37) through processes of negotiating and disputing (that) urban space. The Walled House was deliberately designed to perform and instigate that kind of *political* spatial agency within its surroundings.

In my understanding, and continuing the above reasoning, the Walled House not only wanted to be a spatial stage but simultaneously aspired to be the primer for a specific kind of *time*. To this I relate the idea of “thick time” as described by Till. This kind of time is a “multiplicity” of times coexisting, and as such “presents a diversity that architecture has to accept” (Till 2009, p. 95). The failure of the Walled House—the difference between its design and execution, between being political and policing—can be seen as symptoms of loathing for such a view of time. As built, the Walled House partially counteracts the tides of time that could have seized its body—the possibility of everyday but phenomenal things overcoming it. It counteracts the effects of its possible occupations. The set of creative agents connecting to the Walled House’s cliff and floe, if it had been built as designed, would have multiplied, connecting the agencies of architects, users, passers-by, occupants, fellow creatures of all kinds, and time. While the jury for the architectural competition already called for a rearticulation of the north entrance corner (the usual fear of the dirty corner or the odd uses it might afford), in the outer scale of the house as built, every possible presence of human occupation was in similar ways meticulously and preemptively erased.

THIS THESIS'S PRAGMATIST APPROACH

In the above sections, I have presented one of the principal artifacts of this chapter in detail: the Walled House project. With its construction in reality, awaiting in turn its own constructions or productions; with its adoption here in this thesis, I have aspired to give substance to the re-conceptualization of architectural artifacts, aesthetics, and design attitudes that I set out to explore. While this aim is similar to that of Chapter 1, the experimenting ground has changed. In this chapter, the Walled House project will reappear regularly. It will be embedded in a landscape of thought centered on (critical, political, and) ethical capacities of architectural artifacts.

I will examine the Walled House from the perspective of approaching architecture *pragmatically*. As elaborated in the sections on methodological approaches, my research itself can be seen as rooted in a pragmatist perspective. It works and evolves through the designing and constructing of concrete projects, thereby deploying the aforementioned methodological approach of *research-through-practice*. The pragmatist approach is seen here as conjoined with ethical concerns and capacities (projecting through project). Such a pragmatic approach is therefore in sharp contrast with some pragmatist perspectives touched upon in Chapter 1. I refer back to the idea of *cool* (merely) pragmatist approaches which oppose *hot* critical ones.

The pragmatist approach here not only insists on an association with architectural ethics, it seeks to explore where architectural ethics are to be situated. It seeks to explore architectural ethics in the field of tension between human-centered and object-oriented pragmatist approaches. Without intending to give an exhaustive overview of the many different versions of pragmatist approaches to architecture, I will now examine some aspects of relevance to this thesis, its ways of working, and its resulting artifacts.

Pragmatist approaches in general will reject the idea that thought is there merely to describe, represent, or mirror reality. Instead, pragmatist thought is seen as a tool for action and oriented toward effecting change. Things are valued in terms of their practical uses and effects. Thus, a true pragmatist approaches reality as changeable and ready for action, not as a fixed entity out there to be understood or critically studied retrospectively. Seen in this way, reality becomes a construction site in which speculative projects and actions are launched and circulate, subsequently producing knowledge on local levels.

In Chapter 2, I will follow two specific paths for infiltrating architecture using pragmatist approaches. A first path will focus on the ethical character of architectural design mentioned above. As will be shown, some pragmatist approaches to and accounts of architecture seem to naturally draw in this ethical characteristic. By following these I intend to both continue and refine the exploration of architecture's capacities already established in the previous chapter and sections. I will touch on different accounts of architectural ethics that attribute an increasingly fundamental

role to the object (or in the case of this thesis, to the architectural artifact) in the production of ethical instances within socio-spatial reality. Certain capacities of the artifact will be illuminated, such as its ability to claim and be vibrant, drawing on authors such as Emilie Hache and Jane Bennet. In the most polarized position of an object-oriented approach to architecture, a connection is made to Graham Harman, promoting objects as alluding, alluring, and challenging. Here a critique will also be formulated on an all-too-evident assumption of an association with pragmatist approaches to architecture.

A second path for infiltrating relates to the idea of architecture as a peculiar instrument within reality. I will draw on some propositions that architecture possesses an intriguing *tool-ness* formulated by, for example, philosopher Richard Sennet, who is frequently identified as a pragmatist philosopher.

I want to stress that, in my understanding, the idea of a pragmatist approach to architecture, which conceives of architecture as ethically engaged and which counts in architecture's effects and consequences, is in no way to be opposed to an architecture that is fascinated by object-oriented aesthetics. As I have already stated, the usual idea of the aesthetic object in architecture just needs to be extended. I adhere to the point of view that there is a productive interplay between pragmatist perspectives that focus on effects and consequences and those focusing on objecthood. It is in precisely such an interplay that an account of architectural ethics can unfold, as will be shown. I believe the artifacts I have added in Chapter 2 testify to this (they are intended to do so), as was the case with the artifacts propelling Chapter 1.

9.1. PRAGMATIST ACCOUNTS OF ARCHITECTURAL ETHICS AND AGENCY

Characteristic for pragmatist approaches to architecture is that they follow experimental making activities that produce speculative artifacts, combining this with a particular interest in effects and consequences. A pragmatist architecture works through projects, producing situated knowledge for action and change. Thus, applying this basic notion of pragmatism to architectural design would mean that the effects and consequences of the architectural artifact are valued first and foremost, rather than keeping the focus on initial intentions and conceptualizations. A second consequence is that that focus is on reaching a degree of change and not merely on mending. It focuses on transforming reality (locally) through acts of an experimental architectural making. Here already the notion of a transformative agency seeps in, and inextricably bound to it is a notion of architectural ethics.

Since this thesis engages with architectural artifacts locally inscribed in the urban environment, such as the Walled House project, defining it in terms of a pragmatist approach would logically put the focus on the effects and consequences that inscription has on the variety of human and non-human actors

affected by it. As I've noted, this was certainly the intention of the house as designed. However, and this is underscored by the detailed description of the house, the role of the *objecthood* of the architectural artifact is also to be accounted for. While I have argued for architectural artifacts to make the generous gesture of receding into the background in order to allow their potential effects to come to the fore, I do not want to downplay the importance of architectural matter and articulation. The architectural artifact in this sense is a *hybrid* object, a zone of mediation between the objective qualities of a given socio-spatial setting and how social behavior affects it and is affected by it. One should thus be critical of neglecting the potential in artifacts' objecthood when developing an interest in what architecture is able to produce in reality. I will forthwith elaborate this position further and so fortify the edifice of a critical, political, and ethical architecture that also works through object-qualities. For this I will connect to a variety of authors who, in line with a pragmatist approach, have brought the vitality of architectural matter back to the surface.

In some of her work, architect and researcher Pauline Lefebvre has pointed out that the introduction of pragmatism in the realm of architecture has recently been paired with promises for an ethical account of architectural practice (Lefebvre 2014, abstract). However, the ways ethics are conceived in different pragmatist approaches to architecture have been radically divergent, sometimes even opposed. Lefebvre questions whether architects “really have to choose between their interest in the production of built objects (in their shape, their spatiality, etc.) and their commitment to broader social concerns” and whether they “must [...] focus on social concerns at the expense of the built object in order to be morally responsible” (Lefebvre 2016, p. 23). One position accords the responsibility of the architect with his or her designed objects, while the other accords it with what is brought about, changed, or transformed in reality. Both postures are often seen as distanced in a polar opposition. Lefebvre's phrase “at the expense of” in that sense is not accidental. There is a risk that, in assuming responsibility outside of the field of architecture, architecture may lose track of some of its identity as an aesthetic practice. In the current of projective (post-critical) architectural practice, as visited in Chapter 1, accounting for the ethical either distances aesthetics and ethics, reduces ethics to aesthetics, or confuses the two. To reference Van Toorn on this, in many pragmatic approaches to architecture, any sense of ideology is replaced by purely pragmatic actions. Here, the architectural artifact is deprived of its potential to be active in more complex agencies.

The idea of architecture engaging in complex agencies draws on the work developed in the field of sociology by Bruno Latour and Albena Yaneva. With regard to the architectural artifact, Latour and Yaneva think of it as a complex “object-in-flight” (Latour & Yaneva 2008; Yaneva 2012, pp. 2, 66). The image here seems to connect to the aforementioned Kwinterian kind of morphogenesis, as in the snow crystal substantiating during its highly contingent fall from the sky, connecting in its becoming to

a variety of aleatory agents and conditions. Latour and Yaneva open the door to a version of architectural ethics and responsibility based precisely on the situated and contingent character of architectural practice, not based on notions of autonomy (of the designed object or the designing architect). The shift from the architectural object as static to its conceptualization as partaking in complex agencies is therefore primarily an ethical shift. According to Lefebvre, this must also be considered one of the main achievements of pragmatist approaches to architecture (Lefebvre 2014, abstract). Ethics are not projected onto but produced within situations—within the thick and highly contingent web of connections that make up reality. Ethics emerge embedded in reality and close to matters of concern. In Jeremy Till's terms, architecture always and essentially "depends" (Till 2009).

But what exactly is the role of the architectural artifact in this web of connections? Is it just an entity and one of many actors, or should we attribute to the architectural artifact the role of the connector, as Yaneva does, for example? Imagining what could have happened in the shadows of the Walled House as it was designed, and thinking about Mouffe's conception of architecture as a possible and potent agonistic stage, I argue for the latter viewpoint. In my view, architecture is by its very nature implicated in the kind of complex agencies described above. Architecture can work this out through its own specific materiality, through its own pragmatics, using its own ways and genres of articulating in order to lay out those kinds of stages on which ethics emerge or are construed. However, this inborn capacity is often neither acknowledged nor brought to fruition, as in the Walled House project as built.

While some pragmatist approaches to architecture seem to be struggling with how to conceive of architectural ethics, either distancing them from aesthetics or confusing the two, other contemporary approaches have proven to be more promising. As stated, I approach pragmatist architecture via the notion of the socio-spatial hybrid object, in which aesthetics and ethics work productively together. This approach aligns well with the aforementioned Rancièrian twin concept of an aesthetics of politics and a politics of aesthetics, which was adopted earlier in this investigation. In the next sections I will connect to some other authors who have developed intriguing ideas on architectural ethics in close relation to the objecthood of architectural artifacts. They testify to a reconciliation of architectural ethics and aesthetics. However, first I intend to further the notion of ethics in architecture by connecting to the concept of "spatial agency" as it has been developed in the writings of architects and researchers Nishat Awan, Tatjana Schneider, and Jeremy Till. In a refreshing way, they systematically bring to attention a multitude of specific architectural practices, each deploying in their own way versions-in-action of an ethical architectural agency—through practice, project, and artifact.

Thus, ideas on agency and ethics in architecture are challenged and expanded. I refer here specifically to the book *Spatial Agency: Other Ways of Doing Architecture* (Awan,

Schneider & Till 2011) and the accompanying and growing collection of architectural artifacts and projects found online at spatialagency.net. In my opinion, the projects adopted in this thesis could be considered as contributing in their own specific way to that growing complex of architectures that are conscious of their ethical potential and agency, which goes hand-in-hand with their object-characteristics.

9.1.1. _ (*architectural*) *spatial agency*

As suggested, the relationship between architectural aesthetics and ethics tends to be blurred and confused. Till identifies a threat present in this confusion, constituting what he calls “the phony ethics of aesthetics and tectonics.” Counteracting this phony ethics, Till states that “a brick has no morals” and that “the careful placing of two bricks together [...] is not an ethical act” (Till 2009, p. 24). The question here is where this statement leaves one when thinking about architecture in general and about the walled artifacts featured here in Chapter 2 in particular? How are the architectural artifact and architectural materiality and articulation related to the production of ethics or ethical instances? And, if there is no morality in the brick, is there morality in the composition of bricks? Is there morality in the hand that designs that composition, or does the ethical begin in the shadows of the brick wall—in the bodies encountering and sensing and appropriating the brickwork surfaces and their porous depths?

In their elaboration of spatial agency, Awan, Schneider, and Till give great emphasis to “a transformative intent to make the status quo better”—to change reality at local points through deploying “other ways of doing architecture” (Awan, Schneider & Till, introduction to spatialagency.net). They draw on Latour, who has proposed a general movement from “matters of fact” to “matters of concern” (Latour 2004a, p. 225). Applying this movement in the realm of architecture, they resolutely favor the consequences of architecture over its objects, stating that the former “are of much more significance” (Awan, Schneider & Till, introduction to spatialagency.net). Indeed, according to Till, it does not suffice for architects to merely take up responsibility in the sense of building well. On the contrary, in order not to reduce ideas about responsibility (and thus ethics) in architecture, architects should take responsibility for other beings. Such “introduction of others into the processes and products of [...] practice, brings with it political and ethical dimensions” and constitutes the very condition to speak about spatial agency (Till 2009, p. 151). Pursuing such an introduction, according to Till, enables architects to think beyond their usual role: from “expert problem-solver” (Till 2009, p. 151) and “arbiter of aesthetics” (Till 2009, p. 175) to “interpretative agent” engaging and exchanging with a varied set of other interpreters (Till 2009, p. 164) and “architect as citizen sense-maker” (Till 2009, p. 151). The latter in a given situation gathers the conflicting voices and (tries to) make(s) sense of it.

Recapitulating, instead of being about building well and

building aesthetically, genuine architectural ethics are about assuming a responsibility for the other. Till states that:

For the architect to engage in the ethical field therefore means to engage with how [...] (social) relations are played out in (social) space. The phony ethics of aesthetics and tectonics freeze that dynamic and place all the attention on the contemplation of the object beautiful and refined, a state of removal for both viewer and viewed that can be reached only away from the flux of everyday space. (Till 2009, p. 176)

Till relates to this idea of social space the idea of “social scales,” putting in tension the usual idea of metric scales. 1:100 becomes one architect taking responsibility for one hundred citizens, logically including also a multitude of conflicting voices. 1:1 becomes one human being taking responsibility for another human being. While “the metric scales of aesthetic and technical composition remain,” they now are “in service to” the social. Being thus in service and taking responsibility, according to Till, is what constitutes “the irreducible core of an ethics of architecture” (Till 2009, pp. 178–79). It should be noted that similar thoughts have driven me to set up experiments in different experimenting grounds specifically on a 1:1 scale.

In his reasoning, Till gives a hint of who he means by the quite general *other* for the realm of architecture: “the diverse mix of builders, users, occupiers, and observers of architecture, people whose political and phenomenal lives will be affected by the construction of a building and its subsequent occupation” (Till 2009, p. 173). With the introduction of the other, initial intentions and expectations of designs will be compromised, which is a good and vital thing. Instead of merely accommodating preconceived and quasi-mathematical *functions*, buildings will start to attune to *needs*, which are based more on desires and differences (Till 2009, pp. 41–42).

Till not only rejects the aforementioned phony ethics of aesthetics and tectonics, he also refuses to accept the very idea of an “originary ethics” that would imply that there are “definitively right and proper ways of doing things,” independent of the situations they are part of (Till 2009, p. 173). This, of course, also relates to the idea of right and proper ways of doing architecture. Conversely, ethics are construed within everyday reality, and thus within every new situation. What architecture needs is imperfect ethics, Till concludes, which is “a realistic recognition that the diverse points of view in any situation can be resolved only in as best a manner as possible” and an “appreciation of the differences of the other” (Till 2009, p. 186).

Essential to ethics in architecture is a dynamic of negotiating (ethics). Till also testifies to this, speaking of ethics as “being worked out through shared negotiation” as an “essential condition” (Till 2009, p. 176). Here I refer back to two important instances introduced earlier in this thesis. One is the proposition to architecture of a “critical questioning design attitude inducing the dynamics of negotiation” (Liekens & Janssens 2011). The other is Mouffe’s idea of architecture conceived as an agonistic stage.

What seems to be at stake in all of these is to evoke and empower people's negotiating capacities in processes of making and giving sense. As Till repeatedly suggests, and as has become evident in the shadows of the Walled House, today such an evocation and empowerment is often considered undesirable and therefore preemptively avoided. While the Walled House indeed acted as a refreshing ecological model of urban living (cfr. Van Synghel), it failed to perform the complex agency of giving substance and voice to a complex and ambiguous urban ecology, of providing a stage for difference and a multitude of discordant voices that in their connecting and colliding would negotiate sense and / as ethical instances. In the case of the Walled House, the intended dynamic of negotiation was suppressed.

the role of the architectural artifact in the notion(s) of (architectural) spatial agency

If one does not want to abandon the architectural artifact as an aesthetic and tectonic object altogether, then how should it be conceived? While Awan, Schneider, and Till emphasize the transformative intent of (architectural) spatial agency, Till intriguingly encourages architects as follows:

By all means craft the building, compose the elevation, worry over the detail, but at the same time see these as just some tasks in service to another. The key ethical responsibility of the architect lies not in the refinement of the object as static visual product, but as contributor to the creation of empowering spatial, and hence social, relationships in the name of others. (Till 2009, p. 178)

Is there a relationship between ethics and bricks after all? Are there ethics to be found in the composition of brickwork? It is clear that in (architectural) spatial agency there is an interplay between ethics and aesthetics (and tectonics), wherein the objecthood of architectural artifacts is somewhat subjugated. So where exactly is architectural agency to be situated? Is it in the designing architect, in the designed object, or is it in the occupation and appropriation of architecture? In my view it is in a complex of all of these, and weighing the different agents is what orients and characterizes the different perspectives on (architectural) spatial agency.

As Schneider and Till have argued, the notion of agency is being used (and perhaps abused) with increasing frequency. Now it "can be associated with the most conservative of actions" (Schneider & Till 2009, p. 97). Schneider and Till's notion of agency is fundamentally engaging. It reveals, empowers, and seeks to transform. Such a notion, in my understanding, can be situated close to the critical, political, and ethical capacity I assumed present in (the deployment of) architectural artifacts in previous sections and chapters. That sheds light on a collaboration and even a unity between the critical as an act of revelation and the political (and ethical) as an empowering act of projective action and transformation. Schneider and Till have argued that architecture as a discipline is "inherently political and therefore immanently

critical: either by negating or confirming a position” (Schneider & Till 2009, p. 98). For me, this affirms the tandem of the critical and political (and ethical) I attempt to bring to the fore in this thesis. Schneider and Till see their work as “attempting to make a case for architecture as a socially and politically aware form of agency, [...] critical of the social and economic formations of that context in order to engage better with them in a transformative and emancipatory manner” (Schneider & Till 2009, p. 98). The ambition of the transformation aimed at here is not a revolution. Till defines the ambition rather as an “engagement with existing structures” from which small-scale transformations may sprout (Till 2009, p. 193). Those transformations align very well with the type of urban poesis I have aimed at so far in this thesis.

As was pointed out in Chapter 1, some versions of critical architecture have insisted on a distant and autonomous posture as the necessary condition for architecture to be critical. One alternative that has been formulated, counteracting a dis-entangled posture while at the same time staying far from an uncritical pragmatism, is the suggestion of an “immanent critique” as developed by pragmatist philosopher Richard Shusterman (Shusterman 2010, pp. 34–36). According to Shusterman, pragmatist aesthetics are situated within experience, and since the human body is able to discriminate between experiences, it is able to make critical judgements. Shusterman can be said to align here with an essential idea of projective architectural practice, acknowledging that architects cannot stand outside entanglements with the world, while maintaining simultaneously that architecture *is* critical. Pragmatism thus is not incompatible with criticality but instead offers an alternative conceptualization of criticality (Lefebvre 2016, pp. 28–29). The idea of such an immanent critique pushed my search for a re-conceptualization of the architectural artifact *from within* design(s) (and) practice, visiting designed objects in currents such as critical design but also devising my own specific artifacts that all *embody* their critique, developing it through experiences and encounters. Lefebvre highlights that Shusterman also suggests the presence of a critical potential within the atmospheric and affective qualities of architecture, a potential that is rarely recognized (Lefebvre 2016, p. 29). Both the designing and the experiencing of artifacts, spaces, and atmospheres, in Shusterman’s view, can thus be seen as tools themselves for raising critical judgements. It follows that critical, political, and ethical capacities may be discerned in the brick or the composition of brickwork. It is the challenge for a critical architecture to practice such a critical (and political and ethical) capacity.

Awan, Schneider, and Till’s account of spatial agency and architectural ethics could be interpreted as having a strong human-oriented focus. Whether one talks about the designing architect as an agent aiming to transform and change socio-spatial reality at local points or about the agency of those who occupy architecture, the dynamic seems to be steered essentially by human actors. The role of the architectural artifact seems to be that of a passive mediator between different kinds of human actors and actions. It is indeed hard to think of the

dynamic otherwise. Or, more precisely, one is not used to it. However, in these sections on the ethical in architecture, I hold it as important to also bring to the fore a more object-oriented perspective that enters into tension with more human-centered perspectives, turning it into a more-than-human perspective. Such a perspective is arguably already present in Schneider and Till's understanding of spatial agency, as formulated in their 2009 article "Beyond Discourse: Notes on Spatial Agency." Indeed, they have highlighted the essential difference between *human* agency as described by Anthony Giddens and what they call spatial agency in architecture. While Giddens's agents intervene directly in the world, spatial agency in architecture does this in indirect ways through architectural artifacts. This introduces a notion of artifactual agency as set out by e.g. Latour and Law. Artifacts and architectural objects are important actors in spatial agency. In Schneider and Till's words, "the human agency of the architect is [...] always mediated by the non-human presence of matter and in this mediation, intent is at best compromised, at worst blown apart" (Schneider & Till 2009, p. 99).

Being human, it is quite difficult to think of the dynamic of architectural spatial agency otherwise than as propelled by human intentions and actions. That said, in the conceptualization of architectural ethics, there have been fascinating endeavors that have situated the impetus of agency not merely in human agents. All of these accounts, stemming from pragmatist approaches to architecture as well, argue for a reconciliation of ethics and aesthetics in specific ways that attribute to the object a more fundamental role. The object here is not just a means or a mediator, but an important actor of its own and a connector, somewhat independent even of forms of human agency. I wish to add this kind of account in the following sections, because it brings into balance the architectural agency with which I align—an agency that develops in the tension between human and non-human agents and actions. Before going into these accounts, however, I want to highlight some important consequences of conceiving of architectural artifacts not as static objects but as dynamic objects (-in-flight), that engage in complex agencies, and from this co-constructing ethical instances and sense.

architectural intelligence and situated knowledge; from problem-solving to sense-making

As I pointed out above, Till distinguishes between roles assumed by architects, and with it between different kinds of knowledge / knowing / producing knowledge. There is the role of applying knowledge in the architect as *arbiter*, and there is the role of developing knowledge in the architect as *interpreter*. In the first role, an architect mainly applies propositional knowledge. However, Till promotes the second role for the realm of architecture. He promotes the idea of a "developmental knowledge," as proposed by John Shotter, which works "from within" (Shotter 1993, p. xiii)—that is, from within complex situations and socio-spatial surroundings in which the architect "attempts to make sense of this more fluid landscape" (Till 2009, pp. 164–66). Here the role of the architect is radically that of

one interpreter among other interpreters. In line with the tone of this thesis, and more generally in line with pragmatist tenets, the focus here is again on engaged processes and practices of negotiation and interpretation that lead to further knowledge production. Once more, I argue, there are linkages between this idea of developmental knowledge emerging through processes of sense-making and how we produced the Walled House (and saw the Walled House producing). Till, Schneider, and Awan relate the production of knowledge elucidated above to the notion of “architectural intelligence” (Till 2009, p. 167; Awan, Schneider & Till 2011, p. 39) and its various deployments. This is a movement away from a terminology that speaks of knowledge as an abstract, objective and delineated entity, pushing it in the direction of a more “flexible” and engaging variant (Till 2009, p. 167). It is also a movement away from what Dyrssen calls the “masonry metaphor” of knowledge production, which accumulates and secures knowledge within general and stable hierarchical structures by adding to them one building block of propositional knowledge. Such metaphor to Dyrssen reduces how the judgement of “value” is understood in architecture and architectural research (limiting what could be valued as knowledge). For Dyrssen, it follows that “to enrich understanding, we must re-examine what judgement means as a shaping, constructing and modelling activity, particularly concerning artistic research practices” (Dyrssen 2017, p. 177). In my research, considering the perspective of the architect designing, the deployment of architectural intelligence, of such a shaping, constructing and modelling activity enforcing a revaluation of a current situation, takes the form of what I have called the *preparing, arranging, and deploying* of architectural artifacts. Architectural intelligence then is a (tentative) knowing how to prepare, arrange, and deploy artifacts so that they have a poetic production with critical, political and ethical implications within situations.

With this variant idea on architectural knowledge / knowing / producing knowledge, architecture’s usual main aims are also questioned. As Till brings to the fore, and as I did before in various parts of this thesis, the focus is no longer purely on problem-solving by means of the deployment of *objective* architectural knowledge (Till 2009, p. 167). It is also on architecture as a mode of interpreting and making sense of real situations and socio-spatial constellations and surroundings one connects to. Because the architect-interpreter is joined in creation (and this entails the creation of situated knowledge) by a multitude of other interpreters, as was suggested before, situated knowledge is to be considered construed from various sides in a shared enterprise. The idea of the omnipotent problem-solving architect “brought-up on the foundation of certain knowledge leading to certain solutions” no longer holds. Conversely, some degree of amateurism should be invited in, which would undo the privilege of the expert-architect (Schneider & Till 2009, p. 98; Till 2009, p. 167). Similarly, Awan, Schneider, and Till have argued for “a new sense of what it means to be an architect” (Schneider & Till 2009, p. 98), for “other ways of doing architecture” (Awan, Schneider & Till 2011), and for “other ways of acting” and “other

ways of thinking” in architectural creation (Till 2009, p. 163). The orientation here is no longer on problem-solving and / by objective knowledge. It is on “practical transformative action” (Schneider & Till 2009, p. 99; Awan, Schneider & Till 2011, p. 32).

As identified by Till, the transition from problem-solving to transformative action is part of a paradigm shift that is changing how architecture and its artifacts are conceived. Till refers to John Forester, who re-orientes the metaphor of design from design as problem-solving to design as “sense-making.” It should be noted that it is no accident that throughout this thesis, both in previous sections and in those to come, the notion of sense-making as a designing activity is so often promoted. According to Forester, sense-making is inextricably bound to the idea of “shaping people’s lived worlds” (Forester 1999), and thus with the aforementioned idea of world-making (Goodman 1978). I wish to repeat that, considering the artifacts of this thesis, the idea of sense-making is associated with both the architect-interpreter and user-interpreter. Using Till’s words, the main merit of sense-making (when compared with problem-solving) is that it draws in the social and the political. Sense-making deploys “a model of architectural agency in which social and political issues are brought to the fore and subsequently negotiated through spatial discussions” (Till 2009, p. 168).

9.1.2. _ *congregational agency*

Some intriguing pragmatist approaches are in the midst of developing perspectives in which the (aesthetic) object is accredited a productive, political, and ethical role. Accordingly, these approaches construct accounts of agency in architecture that implicate objects in fundamental ways. While these sections on pragmatist approaches started from the observation that ethics relate to a focus on consequences and effects, now the notion of ethics will paradoxically move close to aspects of architecture’s objecthood. Hence, a narrow-interpreted notion of aesthetics will be broadened in an act of reconciling architectural aesthetics with architectural ethics.

As was suggested before, I am interested here in the advancement of an awareness that architectural objects are naturally equipped with an ethical and political dimension and capacity (agency) that intimately relates to their aesthetic being. Whether the advancement of such an awareness takes place in the experimenting grounds of educational contexts such as the CoMa/CoIn design studio or in more professional architectural practices such as those spawning the artifacts of this chapter, that awareness is much needed in order for designers as well as occupants of the urban environment to see clearly and reconsider the beaten paths of how architectural artifacts are usually seen. Shifting the ontological understanding of artifacts and objects indeed fosters the promise of a reorientation of design attitudes, an ambition I have advocated for on several occasions. To recapture just a few, I argued for a “critical questioning design attitude inducing the dynamic of negotiation” (Liekens & Janssens); I sympathized with

and attempted to practice the idea of para-functionality (Dunne & Raby); I aligned with and set out developing more conflictual modes of architectural practice (Miessen), conceiving of making architecture in terms of an agonistic staging (Mouffe) and a political and not a policing act (Rancière). In their intertwining, all these design attitudes contribute to the substantiation of a (slight) re-conceptualization of the architectural artifact and of architectural practice.

Moving somewhat away from the more obvious human-to-human-centered perspectives on architectural agency introduced above, in what follows I orient the focus more toward the object performing as a non-human agent of change. Returning to the tentative question of whether a brick or a composition of bricks has morality, I turn increasingly toward such pragmatist perspectives on architecture that do not answer that question with a radical *no!* but rather narrow down on that question by asking *under what conditions* an object is moral. In the hesitation here to propose a radical *no!*, another facet of the ethical architectural artifact is disclosed. Hence, in what follows I consider the architectural artifact, the brick and the configuration of bricks, as the propelling force in the dynamics of architectural agency.

matter claiming

Shared across a variety of fields, there is the idea that objects affect the way people see or make world(s). Some accounts of this idea have already been examined. This idea also has advocates in political philosophy. Philosopher Emilie Hache has developed the idea of what she calls “pragmatic ecologies,” in which objects themselves are seen as endowed with a specific “ability to claim” (Hache 2011; Hache cited in Lefebvre 2016, p. 32). Adding to this, Lefebvre suggests that objects are in fact not only capable of exercising this ability to raise claims, but increasingly do so (Lefebvre 2016, p. 33). Lefebvre exemplifies this with the object and materiality of the glacier, connecting also to Latour’s observation of a “general revolt of the means” caused by the ecological crises the world faces (Latour 2004a). In these crises, Lefebvre stresses, “*things*—which used to be mute—are much louder when their existence is threatened” (Lefebvre 2016, p. 33). Of course, as a human one is affected by these threats as well through the claims raised by these things. Glaciers, as object and materiality, affect through their now unusual melting, raising concerns and thought on the general inhabitability of the world. They “gather concerns around them,” thus “becoming moral” (Lefebvre 2016, p. 33). Thus glaciers here become critical, political, and ethical through their performances of unusual melting. Lefebvre adds that here one moves close to a pragmatist view on how values come about. Drawing from sociologist, philosopher and pedagogue John Dewey, she brings to the fore values as neither “prior abstract principles” nor “definitely inscribed into things,” conversely stating that “they manifest themselves in the way we care for things” (Dewey paraphrased in Lefebvre 2016, p. 33). Values, as mentioned before, are themselves sites of construction entangled within situations. In these situations, things “become moral [...] to the extent that moral concerns

gather around them.” This becoming moral of things, this emergence of values, is always a “becoming moral together” (Lefebvre 2016, p. 33), in a congregation of agents gathered around concerns.

Following the above, and bringing the ideas to the realm of architecture, one cannot but attribute moral capacities to artifacts, in so far as they are acted with in congregation. It follows that objects can propel the dynamic of producing values and making ethical claims. A glacier is, of course, the object ideal for demonstrating such ideas. But does it take a giant leap to transfer the idea here from the glacier to the brick cliff and floe we proposed in the Walled House? I argue it does not. It (and other walled artifacts incorporated into this chapter) equally raises questions and concerns on inhabitability; it equally intends to exercise an ability of claiming by offering a stage for that. Indeed, one could argue that things in the urban environment that used to be mute could have become much louder if the Walled House had exercised its agency over its urban site, catching the passerby’s attention and calling for her or his appropriations. Architectural constructions and how they draw in and activate a variety of actors could operate as the very connecting terrain—making visible, giving voice, bringing into negotiation, making sens(e) (ible) the city and with it reality as it is and could be in all its messiness and complexity. In the Walled House’s shadows, values and ethical claims could have been produced related to concerns, unfolding in the ways in which people would have cared for the place as an expanding socio-material configuration. Such values and ethical claims could have been created, only to become crossed and negotiated with other emergent and possibly conflictual values, forging from that connection new values. Gaining a voice, as Lefebvre says, the object and its materiality “become political” (Lefebvre 2014, p. 33). Matter starts mattering, and it does so by reintroducing the political and ethical to the (aesthetic) architectural artifact.

As suggested, things’ claims and claiming affect us by raising concerns. In parallel, people become increasingly attentive to such non-human voices due to an understanding that they themselves are in fact directly concerned. Thus, the dynamic of making sense of situations is also fundamentally propelled by objects (in becoming matters of concern) and aspects related to objecthood.

The capacity of claiming present in things is poorly understood, according to a variety of authors, and this goes for the realm of architecture too. Speaking from the field of social sciences, Albena Yaneva has rightly stated that an architectural artifact is always “a thing that is, etymologically, a contested gathering of many conflicting demands.” This is in stark contrast to more usual conceptualizations of the architectural artifact as an “uncontested static object standing out there, ready to be reinterpreted” (Latour & Yaneva 2008, p. 86). As an anthropologist of architecture, Yaneva has developed her ideas by approaching architecture by making pragmatic, ethnographic accounts of it as a way to describe them in their assembled, complex, and messy nature. She has produced such accounts in renowned architectural offices, following how models and drawings are produced, for

example, circulate, and have agency. However, of more importance in my understanding is that, in her work *Mapping Controversies in Architecture*, she has ethnographically followed architectural projects and buildings in-the-making, showing the path of their becoming as highly complex, contingent, and conflictual. Here projects and buildings are brought to the fore as complex socio-spatial assemblages that mobilize heterogeneous sets of human and non-human actors. However, in these assemblages, in Lefebvre's terms, both kinds of actors operate "in strangely symmetrical ways" (Lefebvre 2016, p. 31). While I consider this ethnographical pragmatist approach to architecture to be very valuable, it first and foremost takes effect in the study of architecture, and not really *within* architectural practicing. Thus it contributes a refreshing methodological approach mainly to the field of social sciences and architectural anthropology and survey, studying the socio-spatial phenomenon that is architecture. The question and challenge, then, is how to make Yaneva's ideas active within the practicing of architecture. I align with Lefebvre, who states that the ethnographic approach as it is now being developed lacks "programmatic ambition, except for a methodological agenda" (Lefebvre 2016, p. 32). However, the ethnographical approach as set out by Yaneva could produce accounts valuable for those practicing architecture (those designing architecture and those occupying it), instigating them to rethink their practices and design attitudes in more ethical ways. What becomes possible, according to Lefebvre, is that "the realm of the moral itself is redefined in a pragmatist way" (Lefebvre 2014, p. 34).

The speculative artifacts and interventions the walled constructions of this chapter wanted to be relate to this redefinition of the moral in pragmatist ways. The Walled House was designed to extend the making activity of the project into an afterlife that would have developed in the folds and shadows of the enveloping brick shell. It intended to install a time that I called "an architectural time of suspension"—of both suspense and suspending definite meaning. It intended to include a variety of discordant actors. It intended to deploy, at a local point and in a local situation, a complex and somewhat ambiguous architectural articulation, interceding in the socio-spatial fabric of the urban environment and calling there for processes of sense-making.

In the course of questioning whether there is morality in artifacts, in Hache and Dewey a capacity of artifacts was encountered to raise claims, a capacity that was also identified as being increasingly deployed. However, the dynamic here is still one of "becoming moral together" (Lefebvre 2016, p. 33). In what follows, I will increasingly follow the path of objects being moral *in themselves*, in relative independence from human actors. Rather than intending to make a clear choice between the two perspectives here, it is important that architects of worlds, and more widely inhabitants of worlds, tentatively practice such ways of thinking about objects and artifacts as moral—because they are lenses on certain urgent matters of concern. However, the ability to notice them as such is currently underdeveloped, since one becomes accustomed to our one's usual ways of conceiving architectural objects and reality (and with it ideas on architectural

ethics and architectural agency). Lefebvre emphasizes that once objects' claims are recognized as such, "the contours of the moral [the ethical] itself are redrawn, precisely along these claims" (Lefebvre 2016, p. 32).

matter as vibrant

In the above discussion, moral capacities were attributed to objects and artifacts in as far as they were interacted with by humans. However, much bolder accounts of objects, artifacts, and material configurations of all kinds being ethical are (currently) developed. The tone here becomes increasingly radical, attributing to these objects a life that is (to a certain degree) independent from their relations with humans. Here, objects raise claims quasi independently, opening the path indeed toward a morality being present within the brick or composition of bricks. I will advance two such intriguing accounts.

First, there is philosopher and political theorist Jane Bennet, who urges to think about matter as "vibrant" and vital. The "vibrancy" and vitality here refer to "the capacity of things [...] not only to impede or block the will and designs of humans but also to act as quasi agents or forces with trajectories, propensities, or tendencies of their own" (Bennet 2010, p. viii). There is a "thing-power" pointing at the "ability of ordinary, man-made items to exceed their status as objects and to manifest traces of independence or aliveness" (Bennet 2010, xvi). To alter one's way of thinking in that way would, according to Bennet, accordingly alter one's "established notions of moral responsibility and political accountability" (Bennet 2010, p. 21). What Bennet pursues are "more attentive encounters between people-materialities and thing-materialities" (Bennet 2010, p. x) and an extension of politics (and ethics) as an "exclusively human domain" (Bennet 2010, p. xvi). This she intends to accomplish along several paths. One of these paths is that she endeavors to push the "received concepts of agency [...] sometimes to the breaking point." Another path is that she puts effort into "inducing in human bodies an aesthetic-affective openness to material vitality." Along both paths she opens "a better account of the contributions of nonhuman actants"—a better account therefore of the ontological understanding and the vibrancy of matter (Bennet 2010, p. x). On both paths, Bennet aligns with some of my aims here, intending indeed to re-conceptualize artifacts and accompanying design attitudes. In her effort, Bennet speaks of agency as "congregational" or in "confederation" (Bennet 2010, pp. 20–21), in which there is an interplay of many agents and in which human intention is "always in competition and confederation with many other strivings" (Bennet 2010, p. 32).

Painting a picture of a such more-than-human (even non-human) congregation or confederation, Bennet recalls a sunny morning when she found in the grating of a storm drain on Cold Spring Lane:

one large men's black plastic work glove
one dense mat of oak pollen
one unblemished dead rat

one white plastic bottle cap
one smooth stick of wood.
(Bennet 2010, p. 4)

The congregation of things Bennet witnessed, according to her, “shimmied back and forth between debris and thing,” between something related to human action engagement and something that “commanded attention in its own right, as existents in excess of their association with human meanings, habits, or projects” (Bennet 2010, p. 4). Bennet shows how this dynamic of shimmying back and forth in fact corresponds with the aforementioned Rancièrian idea of the political as a re-partitioning act (see the end of Chapter 1 and description of the Walled House in Chapter 2). A “political act,” Bennet says, “disrupts in such a way as to change radically what people can ‘see’: it repartitions the sensible; it overthrows the regime of the perceptible” (Bennet 2010, pp. 106–07). As said, there is a perfect alignment here with Rancièr’s idea of the political breaking up the perceptible, as such re-partitioning reality. However, Bennet intriguingly adds that in this dynamic,

the political gate is opened enough for nonhumans (dead rats, bottle caps, gadgets, fire, electricity, berries, metal) to slip through, for they also have the power to startle and provoke a gestalt shift in perception: what was trash becomes things, what was an instrument becomes a participant, what was foodstuff becomes agent, what was adamantine becomes intensity. We see how an animal, plant, mineral, or artifact can sometimes catalyze a public, and we might then see how to devise more effective (experimental) tactics for enhancing or weakening that public. (Bennet 2009, p. 107)

In the act of re-partitioning, the material configuration itself seemed to be able to *move* the observer. It seemed to be able to make things happen and to produce effects and affects. The reason that configuration was able to do just that, according to Bennet, was

the contingent tableau that they formed with each other, with the street, with the weather that morning, with me. For had the sun not glinted on the black glove, I might not have seen the rat; had the rat not been there, I might not have noted the bottle cap, and so on. But they were all there just as they were, and so I caught a glimpse of an energetic vitality inside each of these things, things that I generally conceived as inert. In this assemblage, objects appeared as things, that is, as vivid entities not entirely reducible to the contexts in which (human) subjects set them, never entirely exhausted by their semiotics. In my encounter with the gutter on Cold Spring Lane, I glimpsed a culture of things irreducible to the culture of objects. (Bennet 2010, pp. 4–5)

I argue that the thing-assemblage *moving* human agents here bears similarities with some of the material congregations

introduced earlier. One may think of the urban corner Calle cultivated from two phone booths by adding matter to them, hence expanding the congregation and each time probing it for its (renewed) potential and agency. One may think of Cuyvers's *Public House* in similar terms. And I dare to argue that our Walled House as designed could have been such an evolving and probing congregation. It could have evoked those encountering it to interpret and appropriate the material congregation as handed to them by us, the designing architects. These appropriations in turn would have added matter to the congregation—that is, the visiting bodies becoming assembled in the Walled House's matter, but also the traces of social wearing and weathering and the claims that would find expression in the House's matter—again reorienting the congregation's unpredictable course. Things would have acted and would have been acted upon. Things might have happened and they might not have happened. According to Bennet, such material congregations are the kind that “makes the difference, makes things happen, becomes the decisive force catalyzing an event [...] by virtue of its particular location in an assemblage and the fortuity of being in the right place at the right time” (Bennet 2010, p. 9).

Returning to Lefebvre's insistence on redrawing the contours of the ethical (in architecture), Bennet has insisted on certain cultivations among humans (among architects). This is a cultivation to grasp and discern “the web of agentic capacities” (Bennet 2010, p. 38), which entangles all kinds of matter and agents, both human and non-human, and within this “to cultivate the ability to discern nonhuman vitality, to become perpetually open to it” (Bennet 2010, p. 14). The responsibility of the architect as a practitioner, then, is to account for all the involved agents, whether human or non-human, and subsequently to “recognize their agency, hearing their ability to claim, and acting in the face of their consequences” (Lefebvre 2014, p. 34).

Such an approach to artifacts and ways of understanding them is, according to Lefebvre, fundamentally pragmatist. Ethics and ethical artifacts here become constituted fundamentally as “a matter of situation,” which “requires those who are involved in a given situation (designers among others) to note how objects claim and to invent ways to make them matter” (Lefebvre 2014, p. 35). In hindsight, I might say that we designed the Walled House in fundamentally pragmatist and vibrant ways—in fundamentally critical, political, and ethical ways—while being aware of the uncontrollable correlation between the potential and affordances made present by design in the displaced brickwork scale. Our intention was to set in motion a highly contingent urban poesis and to make matter truly matter on a local site in the urban environment.

When I started on this section with an increased object-orientation, I intentionally added to that specific orientation a hesitant *to a certain degree*. Indeed, while the perspective has become more radically object-oriented, Bennet still situates ethics as taking place in the assemblages and congregations in which humans find themselves participating (Bennet 2010, p. 37). Thus, when Bennet speaks of “congregational agency,” it is an agency

that is “distributed” over a variety of actors. Therefore it has not yet left the edifice of a relationality with human agents. So it seems relevant to tentatively push the perspective in the direction of the object, increasing the productive tension, exercising one’s imagination.

matter that challenges

A second and arguably more radical object-oriented perspective I want to add here has been developed by Graham Harman, one of the founders of *object oriented ontology* in philosophy. In my search for alternative ontological views of objects and artifacts, Harman’s theory, like Bennet’s, is also highly relevant. It should be noted that, outside of their own field, both Bennet and Harman are very much present in the debate on objects and ethics in art and architecture. In fact, throughout their work they invite the field and practice of architecture to alter ways of thinking about objects with them. In his 2013 SCIARC lecture titled *Strange Objects Contra Parametricism*, Harman challenges the field of architecture to think about what object-oriented techniques for architecture might be.

According to Harman, objects always hold something “in reserve.” Never are they fully explainable, accessible, transparent, or exhaustible by human relations touching upon them or by other non-human bodies connecting to them. This of course impedes primarily on thinking about architectural artifacts in purely instrumental ways, always driven by external intent and aims. Harman has emphasized that human thought is just one relation between objects and humans, and it does not need to be favored. There are other kinds of intriguing relations, including those between object and object. The intention in science to exhaust objects and produce descriptive knowledge about and with them, in which objects are fully replaceable by their description, is not to be copied in fields such as architecture, according to Harman. Architecture is not the conceiving and making of discursive artifacts. Conversely, architectural artifacts are not fully coverable by exhaustive discursive interpretation and hence resist it (Harman 2013a, SCIARC lecture). Always keeping something in reserve, objects (architectural artifacts) indeed have a life or their own, (also) independent from relations with humans.

* *the under- and over-mining of objects*

Harman states that present-day trends in many fields tend to be “anti-object” oriented. In sketching the problem at hand, Harman’s focus on currents that either “over-mine” or “under-mine” objects is emblematic. On one hand, several practices and fields under-mine objects, seeking to discover things that are deeper than the object itself. Objects here are reduced to more important underlying elements—to parts and particles, so to speak. In Harman’s words, this kind of under-mining fails to focus on everyday objects, such as pebbles and horses, because these are conceived of as merely superficial and as such having no importance. A pebble is no more than its particles. Harman calls such practices “wrong,” not least because they cannot explain

“durability” and “emergence.” Exemplifying this, Harman notably takes the case and object of the city of London. London will always be London even if some of its particles change, he says. And London can annex territory and still be London. Hence, London is “robust” and “open to emergent properties” while still remaining the same object (Harman 2013b, Architecture Exchange lecture). On the other end of the spectrum, there are currents that “over-mine” objects. These state that objects are in fact too deep, so one should only be occupied with their “surfaces.” Thus, everything is surface. In Harman’s words, everything is just “an idea in the human mind.” Everything is power, language, event, network [...], everything is “this play of relations and appearances,” and there is “nothing behind the curtain.” The problem with these over-mining practices, according to Harman, is that they cannot explain change. If objects don’t have anything “in reserve,” or behind the curtain, if they don’t have any “surplus” that is not currently expressed, then “objects cannot change.” When things are only their actions, then the question is how they can ever engage in new actions. Exemplifying this, Harman asks, when the hammer is only its hammer-use, then how can the hammer break?

The critique here on currents under- and over-mining objects gives a taste of the variety of practices Harman opposes, and also leads to a critique on pragmatist approaches. Firstly, as shown, he opposes all practices that favor the human relation with objects or consider this as solely relevant. Secondly and relatedly, he opposes all practices that interpret objects as tools in the sense of their usefulness (to humans) and all practices that as a result favor human praxis in approaching reality. These latter practices hold that one’s unconscious use of tools and objects comes prior to explicit knowledge of them, and that through studying the use of tools one can exhaust the object and tool, know it, and thus come to know the world. Thirdly, he opposes thinking of objects as systems (as in Latour’s actor-network system, for example) because a system cannot create change due to the fact that it is at every moment already perfectly articulated. The only things that can cause change, according to Harman, are outside or exceeding the system. Harman’s explication of the broken hammer idea draws on Heidegger’s tool analysis. My intention is not to enter into a discussion of that analysis and its divergent interpretations, but just to linger on the intriguing relationship between tool and broken tool, between systems and that which escapes those systems at a given point. In my understanding, the reasoning here is relevant for architecture, too, as in the difference between artifacts as designed, as built, and as occupied. In the occupation phase in particular, architectural artifacts deploy a life of their own (breaking away from the hammer, breaking it), entering into new configurations.

Returning to the hammer, the fact that it can break “shows that the hammer is more than a hammer for hammering. That it is also a material object that has fractures and fissures inside itself that you cannot see, that can suddenly let us down by rupturing” (Harman 2013a, SCIARC lecture). Hence, objects and tools such as hammers and architectural artifacts are more than their (correct) use as a tool. Here Harman sees emerging a gap with

pragmatist interpretations of tools. Tools, objects, architectural artifacts, and material configurations all have fissures that enable them to change while staying robust. Thus a tool is not exhaustible by thinking of it as *in* systems—the hammer referring to the right size of nail referring to the right type of board referring to the right sort of wood intended for the building of a specific kind of house—a system in which things take their meaning from one another. Here one might think back for a moment on the gathering—plastic work glove, dense mat of oak pollen, unblemished dead rat, white plastic bottle cap, smooth stick of wood—the working of which is radically different. If tools (objects) were just their place in a system (hammer, nail, wood board, house), then tools would not break. Harman’s reasoning sheds light on the fact that tools also have properties of their own that enable them to break and thus exceed their usefulness. While this characteristic is a proper capacity of objects, architects and humans are not used to wielding it and thus need practice. In my opinion, Harman’s critique helps keep architects clear from an uncritical positioning under pragmatist banners.

Following Harman, pragmatist approaches that focus on effects but think strictly in terms of useful tools glued tightly to (human) intent and purpose cannot be maintained. As I’ve said, there is always this intriguing capacity and promise of objects and tools to keep something in reserve, breaking (away from usefulness, purposefulness, and relationality with outside intentions). In the following sections, I will start from this idea and join the second path for infiltrating architecture along a pragmatist approach, announced earlier. Borrowing from Richard Sennet, I will explore accounts of tools and objects being ambiguous, complex, and resistant—of strange, frustrating, and arousing tools. It should be noted that I do not borrow such notions strictly from Sennet. Closely related to the walled artifacts of this chapter, as well as to the artifacts propelling Chapter 1, each of these notions has already surfaced. I have consciously conceived the walled artifacts that populate this chapter, such as the Walled House, in terms of being or becoming broken; of exceeding their apparent usefulness and initial intent; of being more complex and ambiguous; of being somewhat strange, difficult, and arousing, able still to surprise and make wonder.

In under- and over-mining objects, reducing the object downwards (to fundamental particles) or reducing the object upwards (paying only respect to relational aspects), the object is, according to Harman, treated coarsely. The existence of the “intermediate level of everyday objects” (i.e. the object in itself) is never accounted for (Harman 2013b, Architecture Exchange lecture). However, it is on this intermediate level that objects “allude” and “allure.” Harman defines this alluding and alluring as setting up a tension between the object (hidden) and its surface qualities (visible). It is clear that this dynamic of alluring and alluding breaks away from the dynamic of objects providing discursive knowledge. Here some correspondence with the aforementioned dynamics of shimmying back (Bennet) and of objects affording, as introduced in Chapter 1, can be traced. Elaborating on this latter dynamic, I also pleaded on that occasion

for a less tight(ly human-controlled or -centered) interpretation of it.

It is, according to Harman, the role of architecture “to explore this tension, this allure between the objects and their qualities, and not to reduce these objects to their manifest qualities in the way sciences, natural or social, do” (Harman 2013a, SCIARC lecture). While the under-mining of objects in the field of natural sciences and the over-mining of objects in the field of social sciences could be seen as defensible and probable, Harman states, the field of architecture should be based on the tension between the two, through this dynamic of alluding and alluring capacity. Similarly, Harman challenges the field of architecture to conceive and construct tools and objects (the architectural artifact) as what he has called “the third table” (Harman 2012).

* *matter of the third table*

In the essay *The Third Table* (Harman 2012), Harman draws on Arthur Stanley Eddington’s parable of the two tables, in which the astrophysicist Eddington proposes two kinds of tables that are also emblematic of two kinds of cultures: that of the humanities and that of the natural sciences. Both claim that their table is the only real one. The two tables are the familiar table of everyday life on one hand and the table as it is revealed and described by physics on the other—the table of appearances and relations and the table of particles and atoms. As a natural scientist, Eddington’s sympathy lies with the second table. The first he would rather “exorcise.” To Eddington, the first table is, after all, just a “strange compound of external nature, mental imagery and inherited prejudice, which lies visible to my eyes and tangible to our grasp” (Eddington 1929, p. xii). Based on this parable, Harman suggests that both perspectives on objects are wrong, and for precisely the same reasons. Both are unreal because they are reductive. According to Harman, the only real table or real object is of a third kind and a third culture “lying between these two others.” Harman adds that “perhaps it is the culture of the arts, which do not seem to reduce tables either to quarks and electrons or to table-effects on humans” that can give substance to that third culture (Harman 2012, p. 7). The field of arts (and arguably architecture and philosophy as well) is identified here once more as having specific capacities that the natural and social sciences miss. If in art (and architecture and philosophy) the object is neither a composition of fundamental sub-particles nor a composition of appearances and relations, then the question is how it can be conceived. Harman provides an intriguing answer to this question, stating that in this new perspective, the object comes as a “challenge.” In his lecture *Objects and the Arts*, Harman says the following:

You would never describe an artwork through its chemical constituents [...] or by its immediate effects [...], because the artwork is there as a challenge. You hopefully are going to alter your interpretation, your first encounter, your gut reaction to it, your gut feeling, because it is there outside that reaction, something that guides or sharpens your critical sense as you confront it repeatedly over time. (Harman 2014, ICA lecture)

In my understanding, this idea of the object as a challenge brings clarity to aforementioned ideas such as the object alluring, alluding, and shimmying back and the object raising claims (and going back further to Chapter 1, the object affording). The object as a challenge moves beyond the describable object.

Applying the idea to the walled artifacts that take the stage here in Chapter 2, Harman lingers close to the above on the ambiguous character of a particular concrete wall that is important in a particular architectural project. That concrete wall, Harman states, is both liquid and solid, smooth and rough, natural and artificial, base and spirit. Just like characters in a play, the more ambiguous and complex characters are, the more able to sustain divergent interpretations and resist description, the more interesting they are (Harman 2013b, Architecture Exchange lecture). The specificity of the concrete matter here, I argue, falls short with regard to Harman's compelling idea. One could think of other material configurations when contemplating an intriguing and productive ambiguity (and ambivalence). In the Walled House as designed, it is not (only) the material brick that is ambiguous and complex—both mass and porous (in multiple senses), both mass and composite. The overall architectural body and how it is laid out is ambiguously and ambivalently complex as well, resisting as such a straight and one-dimensional interpretation by actually challenging those encountering and connecting to its flesh, to its materiality and articulation. Conversely, the Walled House as built turned back the construction in an opposite direction, arguably impoverishing it by a disambiguation and thus a simplification into the one and proper (interpretation). In line with the above reasoning, I have thought in similar ways of the architectural artifacts adopted in this thesis, focusing on their challenging nature. To become engaged in processes of sense-making; to become active in poeticizing scenarios of use; to become implicated in an encounter with architecture so that something comes to light from one's usual ways of seeing reality; to shift one's ontological grasp of objects: all these important aspects of the research only come about once objects come as a challenge. Or better, these research aspects only come about when one gets better at perceiving objects as coming as a challenge. This challenging, in turn, could not come about if objects and artifacts were fully graspable, keeping nothing in reserve, eradicating every connection to chance. In Harman's terms, and this I think of as a fantastic challenge for practicing and experiencing architecture, one can only ever be a "hunter[...] of objects," a hunter of third tables, never fully able to catch or formalize them (Harman 2013b, Architecture Exchange lecture).

Epitomizing the above sections, my main aim has been to make a case for a reintroduction to architecture of its ethical characteristic. This I have done by showing how ideas on architectural ethics have unfolded in recent years quasi naturally from a variety of pragmatist approaches to architecture. At the center of the discussion was the notion of architectural agency, and the different interpretations of it were presented and brought close, putting in tension perspectives that are arguably rather human-oriented with object-oriented ones. Related to

the latter perspective, I issued a warning that questioned an all-too-evident adherence to pragmatist approaches to architecture. With regard to the spectrum that became established, spanning between human-oriented and object-oriented versions of ethics and agency, I have consciously refused to take a clear stance. In my understanding, it is exactly the field of tension between these poles that is productive and that constitutes the space where one can “hunt” for (perspectives on) objects, so to speak, and thus for accounts of ethics and agency. Architecture is propelled by looking upon it one moment from one perspective and the following moment from another, as a conversation or confrontation. From whatever perspective one looks, the main contribution of the perspectives explored above is that, recapturing the general tone of this thesis, they each in their own way deal with the ethical (and critical and political) through practicing architecture. In so doing, they reconcile architectural ethics with architectural aesthetics along pragmatist paths. It is my assessment, as I’ve mentioned regularly, that the objects I have adopted and designed in the course of this investigation are to be seen as calibrating themselves according to that spectrum—as exercises also in practicing the different perspectives on such ethico-aesthetic agencies.

INTERMEZZO: CAN WALLED ARTIFACTS BE POLITICAL?

In the above discussion, one of the issues explored was whether the walled artifacts of this chapter are or can be ethical. Before embarking on the announced second path for infiltrating architecture along pragmatist perspectives, I want to recapture a similar and fundamental question already surfaced in Chapter 1: the question of whether architectural artifacts are or can be political. I will touch upon that question once more in this intermezzo, now relating it closely to the walled constructions through which the exploration in Chapter 2 unfolds.

In his lecture *Can Architecture be Political?* Pier Vittorio Aureli brings to the fore a paradox in architecture with regard to the political (Aureli 2014, lecture *Architecture Exchange Series #2*). At one end of the paradox, it is held that architecture cannot be political; on the other, architecture appears to be always and inevitably political. The latter is a stance I share. Aureli associates the fact that architecture cannot be political with the fact that architecture as a profession has historically developed by depending strongly on an ideology of consensus. I have already touched upon this when advocating for more conflictual (dissensual) modes of architectural practice. Aureli argues that, historically, architecture is the embodiment of consensus and therefore cannot be political. Moreover, Aureli states that architecture cannot be political because it is characterized by a strict division of labor in which all actors involved (from designer to occupant) are concerned only with specific parts of the artifact and process (see also the earlier discussion of Findeli's "conception-reception" model).

At the other end of the paradox, holding that architecture is in fact always political, Aureli suggests the idea that architecture is political even in its smallest details. Architectural elements and forms always address a (socio-)spatial condition, which in itself implies an idea of the political. Then any idea of space implies an idea of the political and any idea of the political implies an idea of space, Aureli claims. Architecture as the framing of space thus always addresses an idea of the political (Aureli 2014, lecture *Architecture Exchange Series #2*). Hence, everyday socio-spatial surroundings and one's being in them are permeated with politics, even where one does not suspect it. As mentioned in Chapter 1, this fact of politics being present in the smallest details and in unexpected places has led me to use the terms *political* and *micro-political* interchangeably in this thesis. The latter is indeed more easily associated with people's everyday practices in reality—with their everyday acts and practices of poesis in the urban environment (with which we also intended to associate our walled artifacts).

According to Aureli, the way to solve the contradiction is to assume that architectural form is always political and that architecture as a profession is not. So Aureli acknowledges the political capacity of the architectural artifact but situates it solely there. The political can only take off from the artifact; in Aureli's conception, it does not take off from the practice of architects,

from their design attitudes. In the previous and current chapters, I have formulated arguments that go against such a categorizing and restricting interpretation of the political in architecture. Indeed, architectural practice itself should be aware of its political and ethical capacities and obligations.

a wall enclosing a space

At this point I wish to introduce some other walled artifacts that can testify to the political and ethical dimension and capacity of architectural practice. I draw the attention to some artistic works by Santiago Sierra and Teresa Margolles, in which the element of the wall itself operates as a (micro-)political agent. In an interview with Sierra, Margolles perceives both in his and in her own work “a recurring interest in techniques of obstruction and concealment” (Margolles 2004, *Bomb Magazine*). The work of both artists sheds light on a particular political aesthetics of border and boundary situations. The building and (dis-)placing of walls is a recurrent technique in their artistic practice. While, in the work of Margolles, walls contain literal and physical references to political situations, the walls in Sierra’s work communicate their politics more indirectly. The wall in Margolles’s *Muro Baleado* is in fact the rebuilding of a wall where political executions took place. The wall was deconstructed on its original site and displaced in a variety of other contexts and venues. It is composed of bricks, but just as much it is composed of bullet holes and residual human material. Other walls by Margolles share this technique: they are, for example, made of mud and blood from sites where people were found murdered due to political conflicts.

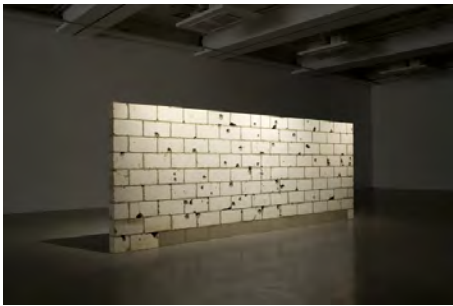

Figure 2.40: Muro Baleado, *Kunsthalle Fridericianum 2010*, Teresa Margolles. Photograph: Nils Klönger.



Figure 2.41: Person Remunerated for a Period of 360 Consecutive Hours, Santiago Sierra. Photograph courtesy of the Lisson Gallery.

In the work of Sierra, walls appear less directly political, gaining a political agency only through certain articulations of use and context. Emblematic for this are *Wall Enclosing a Space*, erected at the 2003 Venice Biennale, and *Person Remunerated for a Period of 360 Consecutive Hours*, which was installed in the PS1 Contemporary Art Center. In general, the first work questions the intimate relationship between art and nationalism, while the second uncannily relates the production of art and the phenomenon of immigration.

In these walled works, the political relies on references to and representations of political issues relating to nations, governments, ideologies, global systems, and so forth, expressing themselves politically through phenomena such as injustice, repression, and conflict. However, I argue that bullet holes and too-narrow cracks containing people are not necessary to make a wall political. As was suggested before, the political resides in the smallest details of architecture, and any spatial deployment already constitutes an idea of the political. The political I am in search of deals with a certain partitioning of (socio-)space—with the inscription of an architectural artifact seen as always mediating a peculiar inhabitability of space, such as ways of being together or separate, of belonging or not belonging to that (socio-)space.

It is worthwhile to (re)construct an encounter with Sierra’s *Wall Enclosing a Space* with the above in mind. Wandering through the Biennale gardens, curious about that year’s selection of artworks to be found in the national pavilions, the visitors are in

for a surprise. Approaching the Spanish pavilion, they are confronted with a freshly and hastily laid wall of cinder blocks closing off the entrance to the pavilion they probably remember from previous visits. Above the entrance, the national designation *España* is covered with black plastic. Their initial puzzlement turns quickly into frustration. Does one leave or does one explore the pavilion's circumference in search for additional clues to make sense of the situation? At the small and secondary back entrance, a uniformed guard demands to be shown a Spanish national passport. Those who have one are permitted to enter, those who do not remain perplexed at the pavilion's outskirts. Those entering the building find inside only traces of past exhibitions and dirt pointing at a general state of abandonment. Whatever category one belongs to, one's senses span from curiosity to confusion to chagrin. At both entrances, processes of sense-making are multiplying. The work of Sierra is not the content of the pavilion here, as it usually is in the context of a Biennale, where art represents a nation, and walls of pavilions preserve the identity of a nation. Quite the contrary, Sierra's work is first and foremost about provoking experiences that raise doubt and at the same time awareness of the specificity of a situation met. It is highly uncertain, I dare to argue, that visitors will become aware of what the artist has aimed for (the uncanny and exclusionary relationship between art and nation). What is certain and intriguing, however, is that people will scan the entrance bodily, trying to make sense of the situation encountered.

In this sense, Sierra's enclosing wall adds to the collection of agentic walled constructions propelling this thesis, which first and foremost act on the micro-political level of everyday encounters and experiences within the urban environment. In my estimation, the value of Sierra's enclosing wall would still stand if no connection whatsoever with the political intentions aimed at by the artist would be effected. Indeed, the architectural artifact or element is not a canvas for political projections, but is producing the political itself. Thus, what makes Sierra's enclosing wall political, in my understanding, is the fact that it provokes, through use and experience, a negotiation of sense. Hence, the wall as deployed has an agency and a life of its own, which to a certain extent escapes the artist's intentions.

Furthermore, and often neglected in the reviews of *Wall Enclosing a Space*, is how the wall is executed to perform its act of enclosing—how it is architecturally and materially laid out in order to make processes of sense-making occur. The wall is not just a wall of basic cinder blocks closing off a space. Exemplifying this, the wall does not coincide with the existing facade's surface. It is not just an infill, but takes a position slightly recessed into the interior of the building. In that way, a cavity space emerges that, when staring at the building, visually disconnects the newly erected wall from the frame formed by the building's entry. As a consequence, the two walls become physically separated by a depth that is visually perceived as a shadow or dark space between the two. This layout invites the passer-by to explore the depth of the darkened edges in search of an entrance and clues to the paradoxical situation. One approaches the wall enclosing that space, steps into the niche, turns to the side, and in the darkness



Figure 2.42: Palabra Tapada (Covered word), Installation view of Wall Enclosing a Space, Santiago Sierra. Photograph courtesy of Galery Peter Kilchmann, Zurich.



Figure 2.43-44: People exploring the recess of Wall Enclosing a Space, Santiago Sierra. Photographs retrieved from <http://www.noshowmuseum.com/en/2nd-b/santiago-sierra> and http://www.artnet.com/magazine/features/filippi/filippi6-29-07_detail.asp?picnum=11.

finds nothing but the hermetically closed joint between the wall and the building. Connecting this sensation to the Walled House as designed, I wonder what could have happened if we had been able to develop in detail the brickwork cliff and its public niches, the public and claimable floor, orienting the detailing in this (subtly estranging) direction?

It should be noted that the aforementioned architectural artifact of Cuyvers's *Public House*, constructed on the edge of Felix Hap Park in Brussels, works in similar ways. It too is a work of art that escapes from the usual confinement of the exhibition space. Instead, the architect has opted here to perform an incision through an architectural intervention disrupting the park's enclosing fence or wall at one specific point. A distinction and complication is made between the identity of the exhibition grounds and the adjacent genuinely urban public space. While the work is tied from its conception to ideas about the relationship between art and life, for those who visit the *Public House* or project uses onto it—sleeping on its bed, writing at its table, looking through its narrow windows, desiring to spend a forbidden night, desperately seeking to be sheltered—for these users the context of the art exhibition has no relevance. For them, this place connects instead to their daily existence within public space—to their own particular position being inside or outside of things, to their own private joys, struggles and desires.

the Walled Landscape of Refugees

In concluding Chapter 1, I already introduced a project working with walled fragments as part of an investigation to explore the infra-thin dimensions and capacities of the element *wall* to be displaced in the urban environment. Building further on the idea of the displaced wall, I want to refer at this point to a project I co-authored called the Walled Landscape of Refugees. This project came into being as an entry for a Dutch architectural competition in search of concepts to house refugees, mainly after the catastrophic events in Syria starting in 2015. For that competition, I collaborated with two former students of mine, Marie-France Lebbe and Lisbet Cools. In the ultimately short period of one day and one night we prepared an idea, a conceptual drawing, and a short text.

Our point of departure was the fact that at that time the debate on the refugee problem was permeated by the notion and imagery of walls, whether these walls were seas or borders to cross, tools for keeping in or keeping out, or instruments of surveillance or protection, and whether they were there to provide some degree of intimacy and belonging or to instill fear. The wall seemed to be one of the most present and active actors in the controversies that kept Europe occupied.

From the outset we decided that we should work with the wall as an instrument, both separating and joining, both ordering and affording incremental occupations to gain footholds. Hence, from the outset we decided to propose the building of a series of walls in a landscape: the Walled Landscape of Refugees, mediating notions of territory. In various spaces between those walls we would provide the opportunity for a more informal infill, tailored

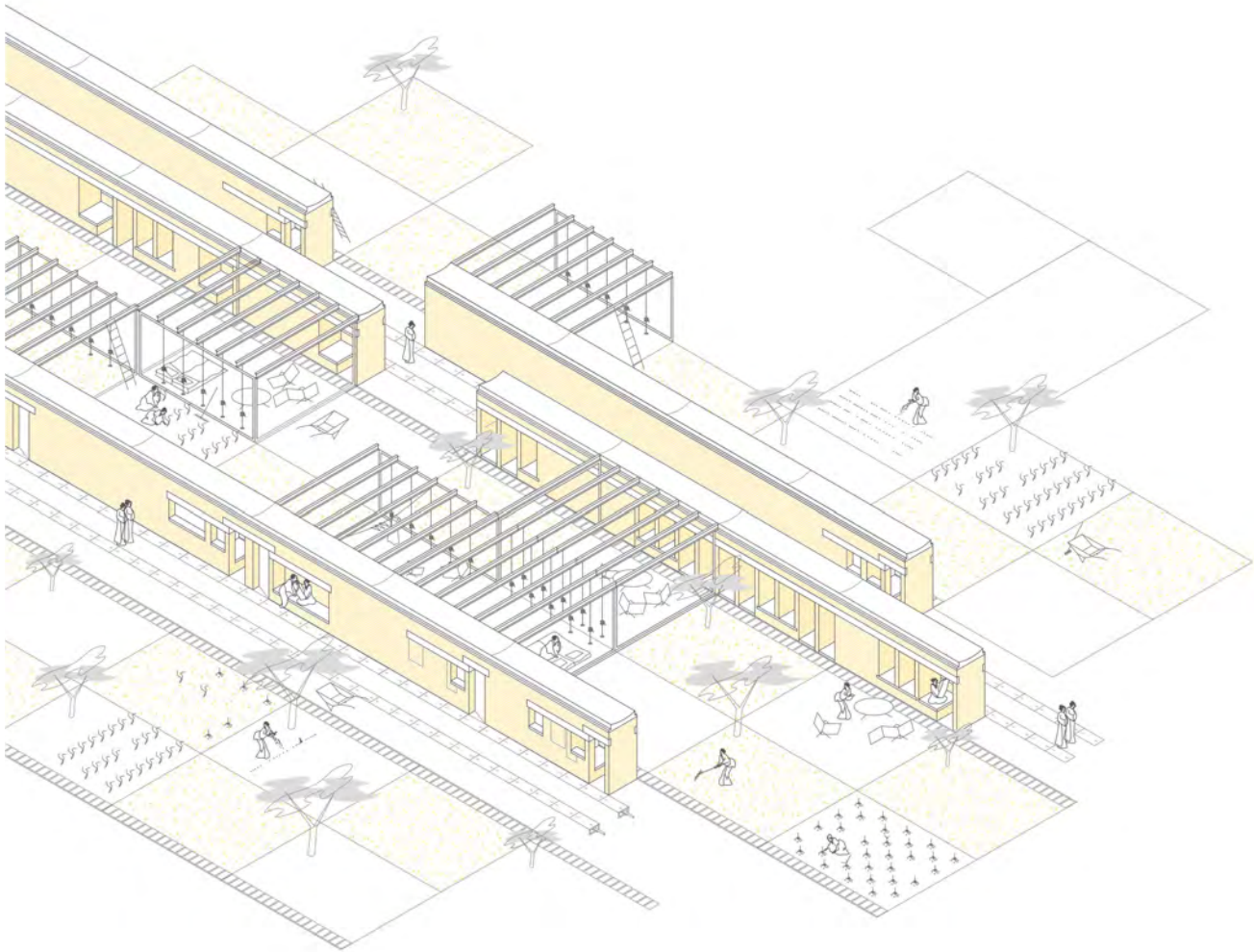

by and suited to the particular needs and wishes of refugees with divergent backgrounds. That informal filling in would enable the landscape to continuously transform, while the formal and pre-built walls gave the landscape a degree of stability and robustness.

We envisioned that walled landscape coming into being in the most difficult, unused interstices of the urban environment, itself perceived as a fertile condition for refugees to stay in touch with the world in every sense. The composition of walls would be able to take on the most irregular of sites. The intention was to create a meaningful urban fragment in which the life of the city would be mingled with the life of refugee housing.

In order to achieve this, some ideas were connected to the walled landscape. As was suggested in the competition brief, the refugee housing would have to be able to vary its occupation over time. Sometimes the function of housing refugees would be dominant, while at other times that demand would diminish and retract, inviting other occupations to develop. We subsequently decided to add a program of urban gardening to our walled landscape. It would provide a durable activity for whatever kind of occupants the walled landscape would foster at any given moment. It would mingle all of these occupants in a common activity. Just as is usually the case with traditional agricultural plots, these would have alternating uses to keep them fertile over time in every sense. One moment the landscape would be one of gardens, another moment it would be bustling with people, and

Figure 2.45: The Walled Landscape of Refugees. Drawing: Johan Liekens.



Figure 2.46: *Bathhouse Women*. Drawing: Torii Kiyonaga.

still another moment people and gardens would alternate from one plot to another.

As already hinted at, our proposal was to conceive the building of the walls as only one half of the program. The other half would open up to a passionate incremental occupation of walls and plots, grafting onto the articulated footholds designed into the walls. This we saw materialized by using and providing re-usable standardized building materials like those found, for example, in scaffolding solutions. This incremental infill would be built over time by the community itself that would inhabit the walled landscape rather than by professionals in advance like the walls. In this way, a certain solidarity could more naturally arise, centered around the making activities of construction and urban gardening.

We just as firmly believed in the importance of this incremental part of building the walled landscape, affording each and every refugee or grouping of refugees an opportunity to articulate their way of living, to express their own degrees of togetherness and separation. For this, we were inspired by some of the woodblock prints by the Japanese ukiyo-e artist Torii Kiyonaga, especially his bathhouse paintings. In *Bathhouse Women*, people can be witnessed in an intimate but common bathing scene, where a wall of detailed paneling mediates the communication with and separation from adjacent spaces and, accordingly, from adjacent bodies.

The description above speaks of the Walled Landscape of Refugees in a non-conflictual, almost tender way, and maybe it could be like that. However, it is clear that the structure as it is conceived would also afford the articulation of the differences that are arguably inherent to the situation of refugee housing and concentration, to the challenge of refugee housing meeting the existing urban construct, and to every form of togetherness.

In this short intermezzo, I have recaptured the idea of a political capacity residing in architectural artifacts and the political instances they are able to produce, drawing that idea near to the walled protagonists of this chapter. The intermezzo also continues the narrative developed in this chapter, associating architectural aesthetics with architectural ethics, and thinking of this in the tension of a more-than-human perspective. In the walled artifacts featured in this intermezzo, larger political issues appeared intertwined with the micro-political level of everyday practices and acts of urban poesis, a level I specifically sympathize with.

9.2. PRAGMATIST ACCOUNTS OF ARCHITECTURE AS AN INTRIGUING TOOL AND INSTRUMENT

In the following sections, I will embark on a second path for infiltrating architecture along pragmatist perspectives by reconnecting to the challenging nature of architectural artifacts.

In a first part of this section, I will connect the artifacts of this chapter to ideas stemming from pragmatist philosopher Richard Sennet. Here I will explore ideas on artifacts (and instruments) that operate as tools he calls “resistant,” “ambiguous,” “complex,” “strange,” and “arousing” (Sennet 2008). In a second part of this section, I will connect the artifacts of this chapter to Albena Yaneva’s notion of “the adjectival architectural,” which considers architecture essentially as actively connecting and thus continuously “in-flight” (Yaneva 2012). I will also connect to John Rajchman’s idea of “the architectonic,” focusing on architecture in terms of intriguing “constructions” (Rajchman 1998). The constant throughout the section is how some pragmatist approaches to architecture have developed intriguing ideas on how the architectural artifact operates in challenging and more-than-instrumental ways. With these sections the ongoing narrative and tone of this chapter is continued and further advanced.

9.2.1. *working with resistance, ambiguity, and complexity*

Recalling the productive parallel of functionality and para-functionality, for example, or the idea of the broken tool and its fissures, the idea of objects keeping something in reserve, the idea of a poetic extension of notions such as affordances, it is clear that notions of ambiguity, resistance, and complexity have already infiltrated the course of this thesis on several occasions. One might also think of the resistance present in the concept of “an architectural time of suspension,” which I advanced in Chapter 1. Resistance here came as a slowing down of architecture, as keeping things in suspense and thereby suspending a crystallization of a definitive and unique meaning (and function). One might in this light also think of the arguments made for more conflictual models of architectural practice, which, by admitting agony and dissensus, resist unambiguous models. One might think of the specific notion of complicating interiors, for example, or that of challenging, alluding, and alluring objects. One might think of the complex and ambiguous architectural bodies of the Walled House as designed and the Walled Landscape’s concept, resisting a one-dimensional proper functioning and appropriation. Given this strong presence of notions of resistance, ambiguity, and complexity, they deserve to be elaborated more specifically now.

identifying with resistance, ambiguity, and complexity

As noted, I will regularly make reference to Sennet, and specifically to his work *The Craftsman*. In architecture in general, and in the architectural projects adopted in this chapter particularly, I hold craftsmanship to be of importance, presenting

itself in a variety of ways. To name but two, craftsmanship can be thought in terms of certain ways of materializing architecture but also in terms of wittingly inscribing architecture in reality and thereby re-figuring reality. It should be noted that in the (co-) authored projects adopted in this chapter there has been an increasing focus on craftsmanship. With regard to this, in the walled construction that is the Research Studiolo, a project that will conclude this chapter, an intertwining of all these kinds of craftsmanship has been the challenge and *modus operandi*. There, the usual division of labor is suspended (between different kinds of craftsmanship), fusing also the phases of conception and reception. Resistance here is thus organized against the compartmentalization between conceiving, building, and experiencing architecture, each of them seen as a way of constructing. Instead an opening is made for the messy reality of architectural creation.

In *The Craftsman*, Sennet brings to light some linkages between pragmatist approaches to reality and the notions of resistance, ambiguity, and complexity. Sennet draws from John Dewey, one of the founding fathers of Pragmatism as a philosophical current. Aligning with Dewey, Sennet promotes a “positive learning from resistance” as one of the forces driving human activity. Like Dewey, he promotes the need “to understand the resistances you encounter rather than aggressively conduct war against them” as a way of grasping the notion of cooperation with the obstacles one meets (Sennet 2008, p. 225). What is compelling here is the idea that obstacles are considered necessary in order for change to be produced—for something new to come into being. Bringing this idea of cooperation to the realm of architecture, the latter being entangled in and tangling with socio-spatial contexts, milieus, ecologies, and (urban) environments, one cannot escape connecting it to issues such as (co-)habitation and socio-spatial (in-)habitability. The idea of cooperation advanced here is clearly not a docile one, but one that fully embraces the difficulties and potential that come with resistance, ambiguity, and complexity. Here the aforementioned argument for a more conflictual model of architectural practice is more thoroughly supported.

Sennet distinguishes between two sorts of resistance: the kind one finds and the kind one makes (Sennet 2008, p. 214). This difference, or rather the combination of the two, is important when thinking about resistance from the perspective of architecture. In architecture, the two forms of resistance coexist. Architecture can be confronted with obstacles and deal with them, but just as much architecture can throw up obstacles and hence create or organize resistance. By doing so, it can invoke those using the architectural artifact to make sense of the obstacles constructed, and thereby make them more resistant themselves. This of course connects to the ideas I explored in discussing architecture as a practice that prepares in specific ways its instruments (connecting to Rossi), its stages (connecting to Mouffe), and its worlds (connecting to Goodman and Nancy). Resistance found and resistance made are co-constitutive in the field of architecture. An interesting experimenting ground opens here for the architect in *making* instances of resistance and

admitting consciously certain ambiguities and complexities instead of just finding and dealing with (overcoming and solving) them.

Thinking along the specificity of the artifacts of this chapter, complex and ambiguous edges can be made that anticipate resistance. Thus, working with resistance by intentionally making things (or revealing things as) more ambiguous and complex becomes a technique of investigation, a technique we practiced with the Walled House. As Sennet suggests, made difficulties, when applied to a context or situation, embody “the suspicion that matters might be or should be more complex than they seem.” To investigate these contexts and situations, Sennet states, “we can make them even more difficult” (Sennet 2008, pp. 225–26). Thus, there is a world to be discovered by the architect in the (subtle and strategic) cooperation, improvisation with, and deployment of obstacles and resistances.

Furthering the exploration at hand, it is also useful to linger a moment on Sennet’s related promotion of (positive) frustration—the kind of frustration one experiences when encountering obstacles or resistant, ambiguous, and complex things or situations. As I have already implicitly suggested, the excitement of a certain degree of frustration also characterizes the artifacts and concepts adopted throughout this thesis. To reiterate just a few, one can think of the notions of user-unfriendly, not-fit-for-purpose, and para-functional artifacts. One may also think of the political and not policing objects—of the conflictual ones, the challenging and alluring ones, and the complex and ambiguous ones. Such objects operate rather as “useful irritants,” using Harman’s terms (Harman 2013a, SCIARC Lecture), and as irritants they could be said to provoke frustration. Thinking about how to make frustration operational in architecture, however, one has to move beyond the gimmick. One should not provoke frustration for unclear reasons or personal convictions without deeper purpose. Sennet indeed argues for the idea of a “productive” dwelling in frustration (Sennet 2018, p. 219). According to Sennet, there are three “skills” to be deployed that allow for such a productive dwelling.

First, there is the skill of designers in “recasting” and “reformatting” problems. This first skill can be seen as echoing the design attitude proposed earlier in Chapter 1, an attitude we labelled “a critically questioning design attitude” (Liekens & Janssens, 2011). In order for (this kind of) attitudes to be productive, Sennet suggests they have to be developed into skills. It should be noted that, to live up to this ambition, I have deployed throughout my research the method of working through designing and constructing projects. This working method can be said to demand and bring with it the emergence and application of such skills beyond mere attitudes (e.g. the skill of recasting the problem in moving from one project to another, in moving from one experimenting ground to the other). In re-casting problem(s) in given situations, in the words of Sennet, one will “continue to probe and poke at alternative methods or solutions” instead of settling on the first solution presenting itself—instead of striving for immediate “gratification” (Sennet 2008, pp. 218–19). The recasting activity described here can itself be seen as a form of

resistance and as a productive frustration that slows down architecture.

A second skill Sennet calls out in promoting productive frustration is that of “patience”. For Sennet, the skill of having patience touches directly upon the nature of craftsmanship. He conceives of a craftsman as someone able “to stay with frustrating work,” to exhibit “a sustained concentration,” sometimes even attaining the level of productive obsession. Connecting patience to resistance, Sennet speaks of the deployment of a “temporary suspension of the desire for closure” (Sennet 2008, pp. 220–21). When something takes longer than expected, stop fighting it, he suggests. And I would add, embrace those moments and instances of suspension and watch their productions. It should be noted that when Yaneva characterizes her ethnographic method of approaching architecture *in-the-making* as a “painstaking” process of “following” architecture (Yaneva 2012), the kind of patience Sennet refers to here can be discerned.

The third skill Sennet moves to the fore in working through productive frustration is that one should “identify with resistance,” and with the ambiguous and complex as well. In my research here, I have intended to do just that. Or rather, I have identified the working of our artifacts with the resistant, the ambiguous, and the complex.

Exemplifying the three skills introduced above, Sennet introduces Aldo Van Eyck’s designs for some small squares to fill in voids in Amsterdam’s urban tissue. I choose this example because it can easily be associated with the architectural artifacts devised in the practices of the CoMa/CoIn design studio (Chapter 1) and STUDIOLOarchitectuur’s walled constructions such as the Walled House (Chapter 2). All these designs can be seen as provoking people to “puzzle through tactile difference,” a quality Sennet associates with Van Eyck’s urban bordering artifacts (Sennet 2008, p. 232). In the squares designed by Van Eyck, toddlers as well as adult citizens learn to “anticipate and manage ambiguous transitions in urban space” through encounters with ambiguous (ambiguously laid out) architectural artifacts and borders that “give few directions for use.” In that way, opportunities are provided to “puzzle through tactile difference,” empowering the one encountering (the toddler, the adult citizen) to make sense of them him- or herself. The effect is to stimulate inquiry (Sennet 2008, p. 233). Notably, danger is intentionally not excluded from this experimenting activity. Quite the contrary, the one encountering *grows* an awareness that danger is in fact an inseparable element of wandering the city, but also that danger could be gradually managed by a confrontation with ambiguous constellations. What Van Eyck has made clear, and this is easily transferable to other contexts such as those in which our designs are active, is that things do not always need to be fit-for-purpose, simple, and recognizable. Things can instead be made more complex and ambiguous in delicate ways in order to stimulate one to inquire and probe further and to form one’s own reading of situations. By using ambiguous architectural elements and constructions one consequently learns the city. One becomes actively engaged in giving it sense, in suspending its assumed

neutrality.

The wall encountered in the meadow of Auster's odd story; the brickwork scale of the Walled House; the walls of the *Walled Landscapes*; the walls of Santiago Sierra and those walls still to be discovered in this chapter: they all look for something *productive* in their subtle activation of resistance, ambiguity, and complexity. This, I argue, can be seen as an essential aspect of how the walled constructions in this chapter are constructed and themselves set up constructing activities.

on the distinction between walls as boundaries or borders

Relating to the idea of introducing ambiguity and resistance into the urban environment by means of design, I want to elaborate briefly on the distinction between viewing walled artifacts as borders or boundaries. When describing the Walled House in detail earlier, I used more organic terms, introducing notions such as the *membrane*. Such notions allowed me to better approximate the fluid dynamic of the Walled House's porous scale—its ability to swell and dwindle, so to speak.

In *The Craftsman*, Sennet distinguishes between boundaries and borders. While the boundary is “more purely exclusionary,” the border or membrane “permits more fluid and solid exchange” and thus is “both resistant and porous” (Sennet 2008, p. 227). It is remarkable that a difference in porosity between walls and borders / membranes is exactly what also triggered the shifting terminology in relation to the Walled House. Porous borders and membranes, according to Sennet, are ecologies of intense exchange “where organisms become more interactive.” They are like the sites where layers of a certain temperature meet layers of another temperature, constituting “a watery zone of intense biological exchange.” In such sites, “indiscriminate mixture” is resisted, allowing for differences but also for a certain “porosity” (Sennet 2008, pp. 227–28). These are political sites of passionate construction and transmission rather than sites of a policing enclosure. The example of border ecologies here corresponds remarkably well with how we conceived of the Walled House when designing it. It seems to add up perfectly to the earlier schematic designs for it (the egg, the rubber bands), improving them by introducing to them a fluid vitality. Accordingly, an interplay emerges between how walled artifacts may appear—massive, impenetrable, and obtrusive—and how a wall works—fluid, permeable, and mediating.

The above distinction between borders and boundaries is not just something Sennet invites architects and urbanists to passively observe. Conversely, he calls upon them to deploy the distinction strategically: “Working with resistance means, in urbanism, converting boundaries into borders” (Sennet 2008, p. 229), a strategy that can be discerned in some of the walled artifacts propelling this chapter.

Bringing the above account of urban walls as political borders a step further, architect and researcher Hamed Khosravi links urban walls to the model of cities, highlighting their modes of worldview, inhabitation, and cohabitation (Khosravi 2014). Herein the wall “transcends its role as an architectural element”

(Khosravi 2014, p. 75). As an example, he presents an engraving by Jean-Baptiste Tilliard. The lower half of the engraving is an all-encompassing wall that exactly fits the contour of the engraving as if there was no world outside the wall. If there was one, the suggestion seems to be that it should be kept out. The wall, using Sennet’s distinction, is a boundary and not a border. It defines a square within: a well-ordered territory with checkerboard patterning, which together with the walls makes this inner square as inhabitable, contrasting with whatever is outside. The way the wall is laid out and displaced over the painting, and thus over the territories it represents, it presents the blueprint of a particular urban culture “as an ideological management of space through strict boundaries” (Khosravi 2014, p. 71). In parallel to the engraving, Khosravi advances wall concepts of other cities, which conversely bring out the idea of ecological borders of intense interaction—not just borders that separate, but inhabitable walls wherein negotiation develops, “wherein citizens [...] become the city itself as dwellers of inhabitable walls” (Khosravi 2014, p. 100).

Khosravi does not posit the distinction here as just something an architect or urbanist can passively observe based on historical examples. Instead, he states that the urban project increasingly seems to be about “the process of de-politicizing or neutralizing space” (Khosravi 2014, p. 100). In that process, walls—their construction as well as their destruction and re-figuration—play an important role. In his reasoning, it is clear that Khosravi urges all those creating the city to intercede in the urban fabric by laying out ecological borders (as a designer), by instilling zones of intense negotiation, and by actively negotiating within these borders (as a citizen).

With regard to the idea of some porosity being characteristic of certain urban walls, it is worthwhile to linger briefly on the materiality of the Walled House’s all-encompassing scale. The idea of walls being porous (as in offering potential for occupation) was underscored (perhaps by chance) by a material sense of porosity. Brickwork is known for its porous characteristics. Porosity here technically refers to the ratio between solid matter and pores, and the pores define the performance of a particular brick. They enable absorption and evaporation of humidity, manifesting inside the brick as a tidal line. They also enable traces of occupation to gain presence, or prevent them from doing so, from mosses to depositions of human material, thereby making present traces of both physical and social wearing. In the case of the Walled House the porosity of the overall construction as designed is thus underpinned by a materiality that itself radiates porosity. One tidal line of moisture and traces entering the scale’s materiality is doubled by another tidal line of occupations, performed by a variety of urban actors and actants. In how I described the Walled House, mentioning also the project’s failures in its movement from design to construction, the main problem thus could be defined just as much in terms of “a lack of wall porosity” having overcome the design. The Walled House’s membranes and borders as built are more absolute and of the policing kind, and thus less complex, ambiguous, and of the political kind.

What is valuable here to me is that in the above accounts



Figure 2.47: Engraving by Jean-Baptiste Tilliard. Photograph: Digital Image Archive, Uppsala University Library.

of walls and walled artifacts, both Sennet and Khosravi (once more) identify them as political borders and political tools for architects to work with. In this, it might be an asset to also deploy materiality in conscious ways.

9.2.2. _ *working with probing, provoking, and poetic instruments and tools*

In his *Scientific Autobiography*, Rossi mentions that he has always been fascinated by objects, instruments, apparatuses, and tools (Rossi 1984, p. 2). That fascination can be said to characterize the whole of his oeuvre. In Rossi's drawings in particular one can catch a glimpse of this, the instruments often being displaced in the urban environment. However, in my understanding, in his scientific autobiography Rossi manages to paint an even more suggestive picture of the architectural instrument. Rossi tells his readers the following:

I have always conceived of the term “apparatus” (*apparechio*) in a rather singular way: it is related to my reading and possession in early youth of the volume by Alfonso dei Liguori entitled *Apparechio alla Morte*. This strange book, which I still recall in many images, seemed to me to be an apparatus itself just by the virtue of its rather small and very wide format: I felt that one need not even read the book because it was sufficient merely to own it; it was an instrument. But the connection between apparatus and death also reasserted itself in such common phrases as *apparecchiare la tavola*, meaning to set the table, to prepare it, to arrange it. From this point on I came to regard architecture as the instrument which permits the unfolding of a thing. I must say that over the years this awareness has increased my interest in my craft, especially in my latest projects, where I have tried to propose buildings which, so to speak, are vehicles for events. (Rossi 1984, p. 5)

In these few lines, which cover a long period in the life of the architect and his emerging awareness of architecture, Rossi describes his developing understanding of the instrument from childhood to that posited and practiced as an adult and professional architect. One alluring experience from childhood has developed over the years into an architectural practice of “preparing” architectural instruments and subsequently inserting them into the urban environment, awaiting what will develop from them. Rossi adds to this the terms of craft and craftsmanship, thus acknowledging, like Sennet, the idea of a particular craftsmanship in architecture. In Rossi's case, that is the craftsmanship of preparing architectural artifacts awaiting their production. The idea of a craftsman accumulating knowledge about how to prepare architectural instruments in relation to their production through an ongoing practice and practicing, which implicitly includes instances of chance and failure, is, in my understanding, consciously suggested (and undeniably a

pragmatist approach). This idea of an evolving craftsmanship is indeed also present in the evolving understanding of the instrument from that held by the boy to that held by the adult and practitioner. It is also implicitly present in the notion of *trying* to propose buildings. There is a certain modesty here, in which agency is fundamentally attributed to the architectural instrument itself. Rossi states that:

I have always believed that in life as in architecture, whenever we search for something, we do not find merely what we have sought; in every search there is always a degree of unforeseeability, a sort of troubling feeling at the conclusion. Thus the architect must prepare his instruments with the modesty of a technician; they are the instruments of an action which he can only glimpse, or imagine, although he knows that the instrument itself can evoke and suggest the action. (Rossi 1984, p. 20)

Once the instrument prepared one is never certain of what will happen, yet there is a suspenseful awaiting of whatever will come into being. According to Rossi, architects prepare instruments as “primary elements onto which life is grafted,” as “instruments of an action that is prearranged, yes, but still unforeseeable” (Rossi 1984, p. 20). These instruments are conceived with intentions and intuitions but they also have a life and agency of their own that escapes the former. Like Rossi, I am interested in an architecture that aims at “remaining in the potentiality of the action” (Rossi 1984, p. 20), of suspending an all-too-direct relationship between purpose, instrument, operation, action, meaning, and the effects that these effectuate. What Rossi shows here is that instrumentality in relation to architecture does not have to be regarded as something suspicious and vile—architecture as a means to an end. On the contrary, conceiving of architecture as a tool and instrument promises a poetic production.

This positive account of instruments or tools and their relationship to craftsmanship is also present in Sennet’s *The Craftsman*. Parts of the book tell stories about the felicity of the *homo laborans*, about the skillful hand that uses the tool and relates to the mind, thus developing skill and with it a particular kind of knowledge. Some sections, however, go even further and open interesting (pragmatist) perspectives that link craftsmanship and tool-ness to this thesis in far more intriguing ways. It should be noted that by exploring such accounts of instruments and tools here (in Rossi and Sennet), I implicitly refer back to the title of this thesis: *Architecture’s Poetic Instrumentality*.

In several places in *The Craftsman*, instruments and tools appear firmly intertwined with the production of new insights. They are seen as means to exploration and discovery and hence further knowledge. Instruments are more than merely fit-for-purpose. Sennet shows how using instruments and tools, even when using them in skillful ways, often makes one find things one was not searching for. Innovative leaps happen by using instruments incorrectly, too—from imaginatively ab-using them, so to speak. The latter way of finding (knowledge) by means of instruments and tools can thus be seen as a promising and



Figure 2.48: My flat-headed travel companion. Photograph: Johan Liekens.

productive path to be followed when one truly wants to discover. Again, as in Rossi, a certain modesty can be linked to these instruments and tools, their use and their preparation. There are indeed foreseen uses, but there are also unforeseen ones that lead to unforeseen insights. Sennet states that, in such contexts of discovery, “as in all craftwork, understanding of what one was doing appeared only slowly, after the fact of doing” (Sennet 2008, p. 199). The instrument and its operating is never perfected in a definite sense. It sets out a partially uncertain experiment. This is, as suggested, considered a good and productive thing. In order for instruments to productively discover, quite often degrees of imperfection, strangeness, and frustration are indeed needed, invoking one’s imagination. This of course pertains to the imagination of the one crafting the artifacts, but just as much to the imagination of those using and occupying it as well.

Sennet distinguishes between different kinds of tools that tickle the imagination. Under the common denominator of “arousing tools” (Sennet 2008, p. 194), he elucidates “difficult” and “frustrating” tools, but also “strange” and “sublime” all-purpose tools. Difficult and frustrating tools, according to Sennet, do not just “send the message of clarity, of knowing which act should be done with which thing” (Sennet 2008, p. 194); instead, the tool becomes a stage for imaginative or intuitive improvisation for the ones using it. One might recall here the notions of noise, deviation, friction, chance, difference, and even some degree of “user-unfriendliness” that were invited as valuable guests into some of the complicating machines and interiors described in Chapter 1. One might think also of the idea of the urban improviser encountered at the steel cubicle. (Note that improvisers are characterized in Sennet as those who do not know “absolutely” but “observe and experiment [...] in relation to their own bodies” without a pre-established plan, thereby furthering knowledge (Sennet 2008, p. 236).) One might think of how the niches between cliff and floe would have been appropriated in the Walled House as designed, inviting just such improvisation. Improvising, one starts using tools in unintended ways, and from that a certain unforeseen learning may sprout. Conversely, using tools correctly arguably constitutes a practice of repetition. As said, there is nothing wrong with the correct use and working of tools; what is key is that there is relevance to be found in moving beyond the efficient and entering the poetic.

Strange and sublime (all-purpose) tools operate in similar ways. With respect to their contribution to the construction of knowledge, they also surpass tools that are just fit-for-purpose. They do so by specifically offering an abundance of “unfathomed possibilities” and applications, a range that is literally too broad. Thus, they address one’s imagination and stir improvisations as well. The tool that Sennet offers as an example is a seemingly banal one: a flat-head screwdriver. However, it is clear that the idea here could be transferred to any kind of object that affords too many possibilities, and in so doing addressing imagination. As was shown, the table in CoMa₀₂ and the walls of the Walled House as designed work in similar ways, offering an ambiguous abundance of possibilities. They promote the conjoining *and* rather than the

selective *or*. Thus, they suggest an abundance of possibilities hinting at the fact that there are still other (stranger) possibilities to be explored and negotiated. While the possibilities of such tools are infinite, it often is one's imagination that falls short in seeing or imagining all these possibilities (Sennet 2008, p. 195).

Notwithstanding their being frustratingly difficult or sublimely strange, I wish to repeat that all these tools remain functional in some way. Hence they all remain firmly within the realm of functionality and tool-ness. Here I align once more with Dunne and his idea of the para-functional (Dunne 1999, p. 44). I do not advocate difficulty, frustration, and strangeness as gimmicks. What is sought, conversely, is a way to install the most delicate degrees and articulations of difficulty, frustration, and strangeness so that they are productive. I expressed this idea already in the diagram showing an architecture that deviates from a *normal*, functional architecture—a deviation that amplifies a subtle invitation to thought to become a shock to thought. Once more I subscribe here to a pairing of the normal with the strange, the difficult with the evident, the frustrating with the gratifying, the functional with things that are imaginable and poeticize-able beyond.

One more thing I wish to add here is the fact that I think

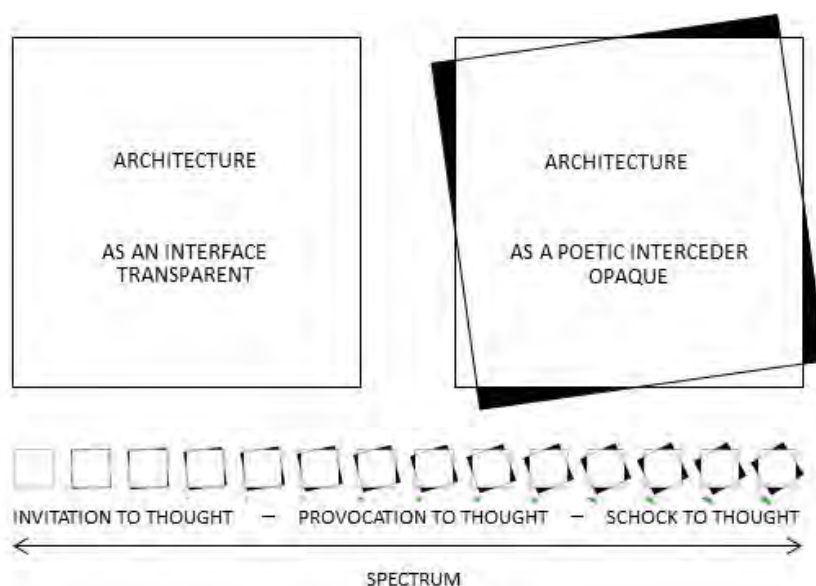

Figure 2.49: Slight but increasing deviations of architecture as we know it, the architectural poetic instrument then exploring a spectrum spanning from an invitation to thought to a provocation to thought to a shock to thought. Diagram: Johan Liekens.

highly of the notion of simplicity in relation to architectural tools and instruments. A contradiction may be perceived here, thinking back to the avowal above to notions such as complexity. In the opening parts of this chapter, indeed, I highlighted this aspect of simplicity of (brickwork) walls, stating that they are ultimately evident and straightforward things, things that constitute the background of everyday existence. Sennet, too, has promoted the idea of simplicity in contrast to that of complexity and a plethora of possibilities. When Sennet uses the flat-head screwdriver as an example, he also thinks highly of that tool's simplicity (Sennet 2008, p. 195). In similar ways, one can think back to some of the walled artifacts that have taken the stage in this chapter. To name but one, I think of the ultimately simple wall found in Auster's novel, which nevertheless developed into an ultimately complex character.

Once conceived in ways as suggested above, instruments and

tools themselves become “a seat of learning” (Sennet 2008, p. 194), and this I argue is valid for the artifacts of this thesis too. Sennet states that:

Getting better at using tools comes to us, in part, when the tools challenge us, and this challenge often just occurs just because the tools are not fit-for-purpose. They may not be good enough, or it’s hard to figure out how to use them. The challenge becomes greater when we are obliged to use these tools to repair [...]. In both creation and repair, the challenge can be met by adapting the form of a tool, or improvising with it as it is, using it in ways it was not meant for. However we come to use it, the very incompleteness of the tool has taught us something. (Sennet 2008, p. 194)

tools to repair and correct

In Sennet’s words above, the correlation between instruments or tools and the idea of making repairs slips in. Cuyvers, too, has spoken in his work of an intriguing making of “corrections” to official programs (Cuyvers 1995). According to Sennet, making and repairing belong to one and the same creative continuum (Sennet 2008, p. 199). It is worthwhile to linger hence on the idea of repairing and correcting as a specific way of making and preparing. Two kinds of repair can be discerned, effectuated by as well as on tools and instruments. One way of repairing takes apart, fixing what is wrong to restore the former state. This is what Sennet calls a “static repair,” in which no substantial change happens (Sennet 2008, p. 200). Such a repair, I argue, merely affirms the thing and its working as it was. If repair is considered a specific way of making and preparing, then a static repair can be considered a form of affirmative (re-)making. In contrast, Sennet promotes the idea of the “dynamic repair,” which changes the current form or function once reassembly is effectuated. The dynamic repair thus constitutes an act of transformation. From this kind of repair, new insights may be gained, while different alternative possibilities might be tapped. While Sennet associates static repairs with tools that are fit-for-purpose, dynamic repairs can instead be associated with the all-purpose tools described above (Sennet 2008, p. 200).

The idea of making dynamic repairs can be discerned in several of the artifacts of his research. My reason for featuring the example of the Walled House with a thorough exploration of two different versions is related to this kind of repairing or correcting in one direction or the other. Curiously, it is the designed version of the Walled House that functions as a dynamic repair of the built version, since intended to conceive of and articulate the urban house differently than is usually done. Instead, we might say that in the reality of becoming built a static repair was undertaken, bringing the urban instrument that is the Walled House back to more usual articulations.

Recapitulating the above, it is clear that the walls adopted in Chapter 2 here all aim at a certain production, which is also a production of novel insights (or at least a revelation of the

inherent complexity and ambiguity of the current situation in which they are set out). Thus, all these walled artifacts intend to instigate processes of re-figuring real situations and hence re-partitioning the sensible (in these situations, of reality). For this they alter usual perspectives on architecture's instrumentality and tool-ness, and deploy poetically productive versions of it that principally challenge their users (from designers to occupants). While Sennet's characterizations of such challenging instrumentality and tool-ness are formulated against the background of important moments of historical discoveries, I argue they also apply to the instruments and tools of architecture as advanced in this thesis.

9.2.3. _ *working with constructions* _

In various sections of this thesis, I have mentioned that my interest lies with notions of *making* and *constructing* (architecture, reality) that go beyond the mere constructing activity of placing, as it were, one brick on top of the other. When talking about architecture as a challenging tool or a probing, provoking, and poetic instrument, more complex (or *complex-ified*) processes of making and constructing are envisioned. The following sections will introduce two such conceptualizations: "the adjectival architectural," as found in the work Yaneva (Yaneva 2012) and "the architectonic," as found in Rajchman (Rajchman 1998). In concluding Chapter 2, I introduce one last (co-)authored project, the Research Studiolo, in which one of the main strategic interventions has been the introduction of the architectural element *wall*.

the architectonic as a way of loosely constructing

Although elaborated within philosophy, Rajchman's ideas of "the architectonic" and of "constructions" clearly have value for the realm of architectural construction and conceptualization. It should be noted that, in his work, Rajchman often opts to speak of philosophy in a vocabulary pertaining to architecture. This can be seen in the outlining of his philosophical understanding of the notion of *constructions*, sketching it as "free, impermanent constructions superimposed on one another like strata in a city" (Rajchman 1998, p. 2). Rajchman tries to conceive the architectonic more in terms of a potential. This is a potential for locally constructing, which never *is* because it continuously engages "the fresh problems" it confronts. A conscious appreciation for the somewhat "looser, more flexible, less complete, more irregular" comes to the fore here, showing an ongoing interest in emerging problems (Rajchman 1998, p. 1). The appreciation of such notions in an ongoing dynamic affords ever-new appropriations, reframing each time that which used to be the frame. The fact that Rajchman suggests that, in such (looser) constructions, things "hang together without yet being held together" (Rajchman 1998, p. 1) gives the impression that these things can still (be) somewhat displace(d), brought closer, or

put at some distance. In this way, constructions emerge as looser and, because of this looseness, potentially poetic juxtapositions, maintaining a certain tension between what is juxtaposed, thereby enabling acts of poesis to unfold and thought to emerge.

Rajchman adds that these juxtaposed elements in a construction are “more flexible, without univocal roles, working through provisional alliances, broken and reconciled.” In these alliances, “what may yet happen” but is not yet there or is not yet articulated is investigated through experiment. Construction hence becomes “an exercise in building new spaces for thought in the midst of things” (Rajchman 1998, p. 2). Thus, construction is an inquiry in the midst of things, aligning once more with a pragmatist credo. As Rajchman points out, construction conceived in this way is “the secret of empiricism, the originality of pragmatism” (Rajchman 1998, pp. 2–3). Transferring the idea here to the realm of architecture, and drawing on Deleuze, Rajchman suggests that such pragmatic constructions are of particular interest when oriented to “the city and its modes of arranging or disposing persons and things—its *agencements* (assemblages)” (Rajchman 1998, p. 3, original emphasis). According to Rajchman, the entire conception of construction, and with it of the one constructing (whether this is the philosopher, the architect, or the occupant, all of these occupied with the construction of world(s)), is therefore “political” and anchored in the relation of “‘the earth’ and ‘the people’ who inhabit it” (Rajchman 1998, p. 3). One might think back here of aforementioned ideas of inhabitability and the making of worlds (Chapter 1). What is generated is a political “time of the city”: a “complex time of the possible ‘compositions’ of our lives” (Rajchman 1998, p. 3). The artifacts in this thesis, and this is certainly the case for the walled constructions featured in this chapter, are the kind of constructions that, through their constructed materializations and articulations, investigate the city as a political, socio-spatial construct. In the above discussion, architecture and the architectural artifact are once more identified as vital activities, processes and actors implicated in fundamental ways in processes of (sense-)making (in and of) reality.

Rajchman states that, “to think would always be to construct, to build a free plan in which to move, invent concepts, unfold a drama” (Rajchman 1998, p. 2). A relation can be perceived to the kind of thinking encountered in Deleuze when speaking of an encounter with something in the world that forces us to think (Chapter 1). Such thinking is itself construction. I am interested in the architectural artifact as an actor and a producer in this dynamic of *forcing one to think*. It takes interest in the architectonic as a way of doing, of heterogeneously connecting without per se pursuing a definite whole.

From the perspectives of Deleuze and Rajchman alike, architecture is an incredibly important activity, “the first of the arts” (Deleuze 1994, p. 186). It is so also because of its implicit and intriguing ways of constructing and constructions. Others, conversely, have considered it a lesser art, or not an art at all, because it is “the most constrained, [...] the most tied to [...] interests” (Rajchman 1998, p. 4). In architecture, however, there is no such thing as purity. Instead, everything is messy through

its being connected. This implies that architecture can never be fully autonomous. In the words of Rajchman, architecture is never able “to create ‘purely’ or ‘freely,’ that is, on its own, from itself” (Rajchman 1998, p. 4). This is what makes architecture so interesting, I argue. Architecture is about the architectural artifact, but moreover it is about the plethora of things it is able to connect its users to, thereby making those things agents in making sense of the assemblage. Thus, architecture is indeed this pragmatist instrument and the architectonic a pragmatist process. The messiness described here has been one of the reasons for shifting the experimenting ground in this thesis, expressed by this chapter.

To conclude this point, according to Rajchman, an aesthetic work such as the architectural artifact is best viewed as “a rather singular, irregular construction built from many circumstances, capable of quite other stranger things than reflecting a beautiful self-accord of nature; often it knows no other logic of development than the crises it goes through.” It is “a kind of sensation-construct of something virtual, unthought, which doesn’t yet accord with anything.” Rajchman adds that an aesthetic work, as a construction, always needs to be “unformed, indeterminate, loose enough that other figurations, other confabulations may yet happen in it or pass through it” (Rajchman 1998, p. 7). Instead of making formal versions of a looser architecture, I argue that what Rajchman proposes here to architecture is the idea of affording some degree of porosity to be seized and of some openness towards change in its being and processes. For this Rajchman proposes strategies that are not “reducing sense but [...] multiplying it”—strategies “of densifying instead of rarifying, lightening instead of purifying, complexifying rather than reducing” (Rajchman 1998, p. 8). All these accord well with the strategies I have brought to the fore and developed within this thesis.

Continuing to linger on the messiness of architecture and its being constructed from all the circumstances and crises it goes through, I will now connect to Yaneva’s idea of the adjectival architectural and of following architecture.

the architectural as a connector in a cosmos of conflicts

In *Mapping Controversies in Architecture*, Albena Yaneva states, “the story [...] of design in the making is [...] a story of the making of the social” (Yaneva 2012, p. 3). It follows that architecture (an architectural construction) cannot be understood by contemplating it from a distance. On the contrary, Yaneva claims, it can only be understood in the interplay and connections between humans and non-humans, which makes it fundamentally a heterogeneous aggregate (or assemblage) (Yaneva 2012, p. 45). Thus, to study architectural constructions or artifacts, one has to meticulously study “their specific ways of working, the worlds they generate and the worlds that set them to work” (Yaneva 2012, p. 23). To study an architectural artifact, “we need to find a way to draw all the worldviews connected to this object, its cosmograms” (Yaneva 2012, p. 67). Allocating this degree of importance to the working and life of architectural artifacts adds to an interest in the artifact itself, in its own (social) performances and

productions. By deliberately using the image of several worldviews as connected into or onto an architectural artifact, the idea of conflict (Yaneva uses the term “controversy”) introduces itself here naturally. If there are different worldviews, and if architecture is the terrain that connects them, then these differences will quite naturally trigger some degree of friction and conflict. As has been suggested before, this acknowledgement of a natural presence of conflicts and this allowance for conflicts to be played out is a good and productive thing.

The notion of worldviews colliding may induce the idea of major dramas. However, this thesis appreciates the small dramas that unfold on the stages of everyday life, and is rooted in the everyday practices of people sharing and contesting urban space. In the distinction made between the Walled House as designed and constructed, one can also speak of different worldviews colliding and coming in conflict by bringing out different ways of conceiving of the urban environment and its in- and co-habitations.

* *from architecture to the adjectival architectural*

In ways similar to Rajchman, Yaneva opposes the conception of architectural artifacts as static objects, defining what they are and mean “as if they are things to be fixed in themselves” (Yaneva 2012, p. 108). Other questions, and with them other conceptualizations, seem far more relevant—questions that gauge, for example, the processes, lives, and adventures of architecture conceived as continuously in-the-making; questions that therefore also deal with architecture’s performances and instrumentalities, as laid out above. A movement is effectuated here from the static architectural artifact to the artifact as a “bird in flight” (Yaneva 2012, p. 66). As a consequence of this shifting conceptualization, Yaneva proposes a shift toward the adjectival architectural, re-orienting architecture and its artifacts toward an intense mode of activity or process:

Architecture is, however, adjectival in nature. Not architecture but the architectural. The architectural is a manner of doing; the architectural is a type of connector. And if we consider architecture as a mode of activity, [...]. We can only follow the differentiation of the activity into different modes as it impinges on different materials and employs different media. It is impossible to name and classify the nuances of architectural experience and processes. The quality of a quality is found in experience itself; it is there and sufficiently there. [...]. It indicates how things are made and predicts the occurrence of architectural events, it tests their presence, and, sometimes, makes us immerse into them. (Yaneva 2012, p. 108)

Architecture and its artifacts can thus be understood as connectors in “a ‘thick’ mesh of entanglements” (Yaneva 2012, p. 2). This mesh is itself a construction, a landscape that itself is continuously in-the-making. Here, when speaking of studying architecture, one follows architecture’s genesis in the actual

messiness of reality and architectural practice. In considering architecture as being in flight, in my understanding, the idea that architecture is constituted by matter, intention, and (trained) intuition is not abandoned. Instead, these are paired with a genesis alongside events, encounters, conflicts, controversies, and chance.

Essential in Yaneva's idea of the adjectival architectural is the importance attributed to the role of the architectural artifact, which is considered not just one of the actors in that thick mesh and mess of entanglements; it is instead the very terrain of construction that connects all the actors who are attracted to or engaged with it. Recapturing here some ideas explored earlier, an aesthetics of the object is paired and paralleled with an aesthetics of process. The aesthetics of use (Dunne) and the political aesthetics (Rancière), which we have explored earlier, can be seen as contributing to the idea of such an aesthetics of process.

* *slowing down architecture by following its conflicts*

It is interesting to follow how Yaneva envisions the adjectival architectural and how this might be aligned with the interest I take here in more conflictual models of architectural practice. One could easily content oneself with the quite general movement from architecture to the architectural, from object to process; however, in the deployment of the architectural, Yaneva attributes specific attention to the notion of “controversies,” which are arguably always linked to a certain degree of conflict (Yaneva 2012). The construction taking place in the midst of the messiness of architecture in-the-making, then, is not just additive—not just a piling up of all scales and kinds of events. On the contrary, it is conceived as productively conflictual, constituting first and foremost a common ground in which conflicts can play out and in which controversies can unfold. Yaneva in this respect states that:

Architecture is made up of intensive forces: actor's disagreements, concerns and the extensive maps of their displacements. A building is not a static entity composed of symbols, but a flow of trajectories. Architecture is made up of the dramas of design and construction. It is composed of forces and events; of different materials and textures; of the discordant voices of its makers; of qualities and substances; of passers-by' noises; and of accidents. A building is not a stable materiality, but a fabric changing according to different speeds. It is not a milieu of activities, but a navigational platform. (Yaneva 2012, p. 20)

To the idea that architecture is a type of connector, Yaneva thus adds that architecture is “navigational”—i.e. in the processes of adding and connecting.

Yaneva proposes a method of “following” architecture (Yaneva 2012, p. 43). With this method, architecture can be understood in its partially contingent and often controversial emergence. For the field of architecture, hence, the challenge is to develop this method into a way, a strategy, and an attitude for designing architectural artifacts. To study but also conversely to conceive, design, build, and experience architectural artifacts can be seen as what Yaneva has called “painstaking” processes of

following architecture (Yaneva 2012, p. 59). In my understanding, the term *painstaking* refers here not only to a duration of time, but literally also to the pains of emergence and growth—the difficulties met and engaged with. Following architecture painstakingly implies that architectural time in a certain way gets slowed down. This brings with it a time for architecture to be truly investigative, with time to consider every aspect of its emergence. Emergence and construction are of course seen here more broadly than merely a process of material building, such as putting one brick on top of the other. In a way, the construction of the Research Studiolo which will be introduced forthwith can be seen as enacting the painstaking process of following architecture in-its-making as introduced above.

Slowing down architecture, as said, gives way to conceiving architecture as an investigative process in which the stance of the architect designing and the nature of the inquiry are displaced radically. In architecture and architectural research, the model of “reflection-in-action” as developed by Donald Schön is still often promoted (Schön 1983). This model privileges a dialogue that goes back and forth between the designer and the design(ed). This is how the design process is in-formed. Yaneva, however, develops a sharply contrasting take on that stance and that mode of inquiry. Following controversies or slowing down architecture, one adopts what she calls the epistemological role of the architectural “ethnographer” or “slow researcher” (Yaneva 2014). Adopting that role, knowledge is produced by meticulously following the artifact through all the connections that overcome it or are made by it. This is a different approach than the architect being in an exclusive dialogue with his or her design, somewhat secluded from the reality in which the design is or will be inscribed. Yaneva states that:

Only by engaging in an anthropology and ethnography of architecture can you gain access to that particular moment when the divide between content and context has not yet been made. It is a moment when the architectural and the social are fluid and mutually define themselves. It is a unique moment when all redistributions are possible. (Yaneva 2012, p. 46)

By conceiving and deploying architecture as a type of connector, the social is locally and temporally constructed. Artifacts that were previously conceived as merely technical and aesthetic, according to Yaneva, in the process become “socio-technical, socio-aesthetic and socio-political,” “potentially extendable,” and “modifiable.” In short, they become “contested,” and in this sense they have moved “from rapid to slow” (Yaneva 2012, p. 66). It should be noted that the slowing down of architecture is related here to aforementioned accounts of architecture slowing down. I refer here, for example, to the advancement of an “architectural time of suspension” (Chapter 1)—both a time of suspense and a suspending; a time of delay and detour; a time of resistance to an interpretation of architecture as an all-too-smooth object or process; a time that enables conflicts to be played out and for these conflicts to be made sensible and materialized in certain ways.

The walled constructions of this chapter and the complicating machines and interiors of Chapter 1 can all be seen in that sense to generously spend time on site.

✱ *the adjectival architectural as a pragmatist approach*

Yaneva resolutely places the shift from architecture to the adjectival architectural and the idea of a painstaking following of architecture in-the-making under a pragmatist banner. She states that:

Pragmatism assumes that architecture cannot be reduced to anything. It is real on its own; it has actors, bodies, machines, technologies and groupings all belonging to it. While critical architecture allows for reduction and it constructs the world on the basis of givens, the pragmatist alternative is irreductive. [...] If it cannot be reduced, it is left in a perpetual state of “what happens?”; there are constant hesitations, meandering, trials, attempts and translations. No building can be defined outside of “what happens” to it, outside of its making, outside of a controversy. By the same token, design defines itself, emerging from its participants and objects. (Yaneva 2012, p. 43)

Yaneva hence advances a pragmatist approach to architecture that follows controversies as moving beyond the more reductive current of critical architecture. Although I follow the argumentation, I have outlined in the previous chapter the main concerns with regard to such a sharp distinction. That said, Yaneva’s thoughts are challenging, encouraging one to conceive of architectural artifacts as meandering, trying, attempting, and happening only and always connected in a mesh of controversies. The artifacts adopted in this thesis do not illustrate a criticality that merely points at a problem, driven by morality, intending to reveal some hidden societal mechanisms that are wrong or unjust. I have made it clear that what I am after is a pragmatist *and* critical, political *and* ethical, architectural constructing activity that aims at local change (in substance but also in perception and thinking). As Yaneva says, such a pragmatist perspective “is respectful of the actors’ own understandings of shared meanings and the practices and procedures they undertake to detect these meanings” (Yaneva 2012, p. 43). Indeed, the pragmatist activity of making architecture is not restricted to the designer. It fundamentally draws in those connecting to architecture and its artifacts, engaging and empowering them in practices of making architecture themselves. Experiment is key here, as are practice and construction.

✱ *the adjectival architectural in architectural education*

In multiple sections above, an alignment surfaced with the organization and intentions of the design studio Complicating Machines / Complicating Interiors (CoMa/CoIn), which is part of the Master of Interior Architecture program at KU Leuven Faculty of Architecture, Campus Sint-Lucas. These sections give a taste of the impact the practice of the CoMa/CoIn design

studio wants to have on the education of the (interior)architect. As stated in Chapter 1, the idea of all artifacts produced within the CoMa/CoIn design studio can be retraced to an aspiration to deploy a common but conflictual ground and stage within reality, which challenges those who encounter it to take the stage. There the (interior)architect in-the-making will situate him- or herself slightly off center vis a vis consensus-based and consensus-oriented models of architectural practice. In such an arrangement, in the words of Yaneva, one starts to “listen more to the voices of the actors than to their own presumptions” (Yaneva 2012, p. 74). One moves away from the dynamic of merely entering into conversation with one’s architectural design. Instead, one engages in:

a pragmatist type of architectural inquiry that is a situation-based, distributed way of learning about architecture and its various entanglements rather than one that relies on a stable stock of systematic, scientific knowledge. [...] It implies an out-of-the-studio way of learning about design, which is simultaneously an out-of-the-auditorium mode of questioning the multifarious connections of architecture, society, economics, culture and politics. (Yaneva 2012, p. 68)

According to Yaneva, such opportunities are urgently needed. In the CoMa/CoIn design studio, it is considered essential that student-researchers do not base their work on a program given in advance. Instead, the students have to find out for themselves what a relevant program or contribution could be and what their role in it could be as a designer and a citizen—a role they can play by spending time on site, engaging with it and its variety of actors in slow ways. There they have to take into account how a program is continuously changed, re-negotiated, and re-calibrated. They have to devise ways to construct from this unstable base while experiencing and incorporating all shifts and changes on site and in flight. They have to devise ways to deploy the architectural and the social as melted and melting.

As already mentioned, the focus in the studio is not on what architecture *means* or *is*, but on what it is able to *produce*. Following Yaneva, it is about “what kind of effects it can trigger, how it can affect an observer, divide communities and provoke disagreements.” Thus, students (and this goes for designers at large) “immerse themselves into the many consequences of design practice and gain an awareness of its various implications” (Yaneva 2012, p. 70). Instead of remaining within the dialogue with the design, students “plunge into the design world outside the studio and face its complex ontology” (Yaneva 2012, p. 70). In all of this, the co-constructive role of the architectural matter is not to be underestimated.

It is interesting that Yaneva does not really propose a definite structure of how to map controversies. Instead, among her students, either in sociology or in architecture, she tries to instill an attitude of pragmatically practicing processes of trial and error rather than emphasizing on the resulting designed object. This is suggested in her words when she states that the

method of mapping controversies “attempts to endorse and cultivate a specific attention to the performativity of design through teaching” (Yaneva 2012, p. 71). Thus, the idea of following controversies is instilled within the student-designer as a way of thinking and practicing. I have from the outset always thought of complicating machines and interiors in similar term and, as suggested, I have also aimed at changing attitudes. In the CoMa/CoIn design studio, one learns to design (slightly different) and one learns about design (slightly different), growing an awareness of its capacities en route. As Yaneva states: “Only through constant attention to the performativity of design can design education sustain its integrity, value and effectiveness” (Yaneva 2012, p. 81).

Of course, the education envisioned here is not restricted to the milieu of architectural education. As mentioned before, I seek to slightly re-conceptualize architectural practice and its hold on the architectural artifact. Yaneva sees the exercises she confronts her students with as “a good rehearsal for the profession of the designer” (Yaneva 2012, p. 79).

✱ *activating the adjectival architectural*

To set in motion the adjectival architectural one has to get immersed in the messiness of architectural practice and urban reality. One has to take seriously all that overcomes architecture in-the-making, follow it, and work with it. Hence, from contemplating the architectural object, one has to venture head up into the messy terrain that architectural construction always is. For this, specific ways have to be devised. Architectural instruments should be in that sense prepared as stages from which the adjectival architectural and the architectonic, as introduced above, can take off. However, the question is whether Yaneva fully succeeds in this when she proposes her method of mapping controversies in architecture.

It is clear that Yaneva has developed an interesting method of survey that follows architecture through the controversies in which it is entangled and through which it has formed. Applying the method, the investigator gets a unique insight into (or rather about) the artifact and the things connected to it. In a way, the overall description of the Walled House itself can be regarded as such a mapping, emphasizing the difference between the house as designed and the house as built. With her method, Yaneva works with students in the field of architecture to survey existing architectural projects. Often these are projects of grand architecture designed by renowned architects. I discern two problems. First, a method of survey is mostly used to survey architectural artifacts after their construction. This kind of survey method seems to be passive and leaping behind rather than active, projecting, or casting ahead, creative while being in-the-making. Using Yaneva’s method, one rather looks back retrospectively at the controversies architecture has encountered. Certainly one learns from this, but one does not create with it. This method of merely surveying and learning is a logical way of doing things in the field of social studies. However, for the field of architecture I imagine the potential in moving beyond a method of surveying and mapping. As I’ve said, it is unclear how a method of survey

could have a production that changes something in the reality of an architectural project (en route and not retrospectively). The critique here accords with Harman's aforementioned critique, stating that such methodologies are good for talking about what already happened, but not for talking about what might (have) happen(ed). Harman refers to such theories and methods as "factual," while he thinks of architecture as a "counterfactual practice" (Harman 2013b, Architecture Exchange lecture).

A second point of critique is the fact that Yaneva's method surveys grand architecture only. Probably the reason to do so is strategic. Indeed, the method is applied in an education process that requires projects that are known to all students and that are known to be complex. However, one might mistakenly conclude that interesting controversies can only be found in such projects—projects that bring together star architects with complex programs and even more complex political actors and powers. Should this be intentional, such a selection needs to be opposed. Earlier, I suggested already a movement that brought back the political from the level of state politics and the like to the micro-political of the everyday. I similarly brought back the idea of worldviews colliding to conflictual viewpoints pertaining to issues of everyday inhabiting, sharing, and contesting urban space. In a similar movement, I propose to bring the idea of following conflicts and controversies that develops around architectural artifacts back to the level of the everyday and, more specifically, to the everyday performances in it.

These critiques aside, Yaneva's ideas are refreshing and have great potential for the realm of architecture, especially if one manages to make them active within architectural processes and in artifacts in-the-making. This thesis in general and the walled constructions adopted in this chapter in particular thus take interest in the conflicts and controversies arising parallel to their emergence, translating that interest in an active and engaging architectural practice. In the last part of this thesis I will explore a last walled artifact in which I believe such a following of architecture, such an idea of the architectonic and the adjectival architectural, is present. Before exploring that artifact, one last issue about architectural matter and materiality needs to be addressed.

9.2.4. *liberating materiality*

When talking about the adjectival architectural and the architectonic as ways of loosely constructing, as I did in the previous sections, I suggest that all actors drawn into these loose constructions attain a certain freedom—that there exists no unique, logical and unambiguous relationship and hierarchy among them. This means that materiality, as one of these actors, is not bound by relations of cause and effect. Hence, one can forget some of the often-heard simplifications of materiality, such as the romanticized ones that claim that wood provides the user with rest and peace and that transparent glazing represents democracy. This of course reflects on the poetic instruments and artifacts of

this thesis, which were already hinted at as intriguing constructs moving somewhere between materiality and relationality, between objecthood and effects.

It is not the intention here to give a precise account of what architectural materiality is, what its role is, or how it should be deployed. In my view, this cannot be done. The only intention is to provide some short lines of thought when conceiving of materiality in this thesis. Better yet, materials are deployed in the specificity of each architectural work, and no general statements about it have to be made.

As suggested, materialization here is not conceived of as a kind of representation, signification, or explanation in which intrinsic matter becomes solely a representation or explanation of something else or the carrier of an aesthetic or symbolic meaning. Similarly, materiality is much more than tasteful materiality harmoniously taken in an interaction between the senses and the faculties.

These viewpoints are also traceable in Yaneva's ideas on materiality. The idea in this thesis is to experiment on ways that break away from the division between the object(-ive) and the subjective, between materiality and the social, between that which causes and that which is effect. Instead, I am considering architectural aggregates in which materiality becomes an active actor within a (productive) setting rather than merely having the potential to symbolize and signify or relegating it to its purely technical and aesthetic capacities. Meaning does not follow materiality, nor does materiality follow meaning. Rather, meaning is constructed in a larger terrain engaged by a multitude of actors, one of these being matter.

Matter is an important actor, though: it largely materializes the tactility and sensibility of the encounter, and in that sense constrains and accommodates it in fundamental ways. It materializes footholds for events to unfold, for conflicts to come into view, for controversies to take off, for chance to join in. In Yaneva's terms, by conceiving materiality in that way, one is able to leave behind the regime of representation and enter instead into a regime of "non-representation." According to Yaneva, "all we need to ask is: what does this building *do*?" (Yaneva 2012, p. 23, original emphasis). Adding to this question, another question would be what materiality *does* in this dynamic of doing. To Yaneva, this means that "the multiplicity of matter" is to be taken seriously. It is neither "neutral" nor "passive." It is instead "significantly more active and vibrant than symbolic interpretations of architecture present it." According to Yaneva, conceiving of materiality in such ways has been "systematically neglected" (Yaneva 2012, p. 44). Yaneva states:

Far from needing a spiritual atmosphere or a symbolic aura that will make sense of its "simple nature," matter has a rich and vibrant life of its own. This life can only be described by using the term "materiology" [...]. Materiology is the variability of matter. It does not consider the materials scientifically (analysis of the structure of architectural objects) or poetically (an interpretation that is based on words and poetic meaning).

Rather, materiology accounts for the full deployment of material qualities: the unexpected surprises, the technical gestures of the maker, the unforeseen consequences and the underestimated properties of materials. [...] Follow how architecture happens, watch how matter acts, witness how actors attribute meaning to their actions, track design processes as they unfold. (Yaneva 2012, p. 44)

One can easily perceive parallels here with earlier accounts that attribute to matter characteristics of being vibrant, challenging, shimmying back, alluding, and alluring.

Thus, materials are not to be explored in a solid state but in a state in which everything is somehow and somewhat melted (the social with the material, and so forth). Matter is one of the actors that is to be followed then in agreements and disagreements, in alliances and connections. In this the social can be found (Yaneva 2012, p. 81). Thus, matter can be said to be co-constructive of the social. But matter resists a fixed and servile role in that construction, just as the object was seen to do by Harman. Matter always keeps something in reserve. Even when it is deployed with clear intentions, its effects and the affects it will raise cannot be foreseen.

THE RESEARCH STUDIOLO

Es gibt Leute, die mit Linien, Schrift und Worten handwerklich gut umgehen, und es gibt Leute, die bauen ein Haus.

*(There are people, who craft well with lines, writing and words,
and there are people who build a house)*
(Gregor Schneider, cited in Davidts 2006, p. 10)

The Research Studiolo project initially took off as a small exercise within one of the Research Training Sessions at the Sint-Lucas School of Architecture. The participating doctoral researchers were asked to imagine and draw an image of their fictive *research table* from which their research is conducted. They were asked to portray what is on the table, to what broader contexts it relates, and so on. I add one of the resulting drawings here.

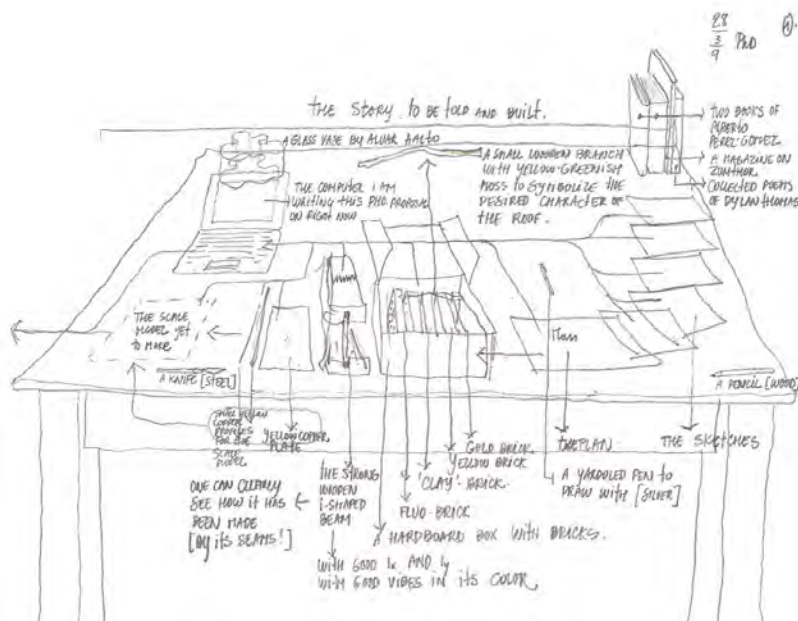

Figure 2.50: Drawing a research table, version by Jo Vandenberghe. Drawing: Jo Vandenberghe.

However, from the outset I wanted to extend the scope of that exercise, moving it beyond a personal research space drawn on paper. I conceived of such a research space as a construction site itself, and with it a practice of constructing architecture *within* the reality of an urban setting. This site and practice I conceived as connecting to ideas that I was exploring at that time in my research, as advanced in the preceding sections and chapters. I recapture some of them here, important in introducing the Research Studiolo project.

There was a strong connection with Yaneva’s idea of the “adjectival” architectural and her method of following architecture “in-flight,” chasing it through a web of connections and alongside a series of “controversies” (Yaneva 2012). As mentioned earlier, I wanted to explore a more active variant of Yaneva’s idea and method in architecture. There was an affinity with Rajchman’s idea

of the “architectonic” architectural as a potential for juxtaposing “constructions” that constantly engage the “fresh problems” they are confronted with, gaining substance “in the midst of things” (Rajchman 1998). There was Kwinter’s idea that an architectural artifact comes into being and evolves as a “snow-crystal-morphogenesis,” developing through connections and collisions with all kinds of “aleatory conditions” (Kwinter 2002). Architecture in all of these is conceptualized as an accumulative activity happening *in time*. While such connections and collisions, according to Kwinter, are often “scrupulously (i.e. by design) eliminated” (Kwinter 2002, p. 26), hence making design complicit in an activity of erasure, in the case of the Research Studiolo I strove to actively count these in and let them steer the development. This pursuit also aligns with how, as a practitioner on a variety of experimenting grounds and in a variety of collaborations, I have always experienced architecture’s coming about as radically *messy* by nature.

As a consequence of allowing in the ideas mentioned above, the Research Studiolo corresponds more with a heterogeneous juxtaposition of fragments than a consistent whole. Fragments are brought into tension over time, allowing an ambiguous reading, resisting premature closure, and aiming instead at a productive instability that keeps things in suspense. The dynamic here is to be considered a way of slowing down architecture. It allows the juxtaposed and juxtaposing artifact to radiate some of these tensions—fractures, imperfections, inconsistencies—as a particular kind of agency that challenges the one encountering to make sense of it. What I wished to counteract with the Research Studiolo is what Sennet calls perfection “of the cleaned-up sort,” which does “not hint at the narrative of its making” and establishes nothing but “a static condition” (Sennet 2008, pp. 258–61).

Rather than strictly following a-priori plans, it is (also) what overcomes the architectural artifact in its slow process of emerging and developing that is constitutive. Of course the Research Studiolo has an official program (an urban dwelling, and separate from this a small studiolo that could accommodate, as an extension of STUDIOLOarchitectuur’s office space, my research and design activities. Answering this official program, proposals have been made in the form of partial plans and drawings. However, these plans have never constituted an a-priori whole to be subsequently implemented. They have been fragmentary at most, produced only when needed in relation to building permits or in the rare case when specialist work needed to be delegated. The plans have generally been secondary to concrete action, to concrete connections made and controversies encountered during construction. The Research Studiolo—as an artifact and a practice—is therefore primarily a terrain of discovery.

In service of this way of *construction*, the time of the Research Studiolo is slowed down in another sense. The division of labor typically differentiating between architectural design and construction is suspended. I have constructed the Research Studiolo myself literally as a painstaking process, thus allowing for connections and controversies to more fully (be) engage(d) over time. The 1:1 scale work again comes to the fore in a multiple sense of being the scale of real matter and that of real encounters,

connections, and thus potential controversies. Materiality is not fully programmed in advance, but deploys more freely in ad hoc situations. Thinking of the labor expended in constructing the Research Studiolo, I am drawn to Rossi's story of a block of stone heaved by a mason into a construction, heaved there with great effort. It strikes the mason that within the block of stone there is a "conservation of energy." The energy expended in bringing it there "does not get lost; it remains stored for many years, never diminished, latent in the block of stone" (Rossi 1984, p. 1). In similar ways I think of the *latent* energy stored within and radiating from the architectural body of the Research Studiolo, an energy resulting from its construction and the tension between its fragments.

Besides the division of time and labor, another division is resisted. It is the one that exists between architectural design and its execution on one hand and the experience, use, appropriation and occupation of architecture on the other. While constructing on site, the one designing and executing is confronted with a variety of other actors who are engaged with the construction site in a variety of ways—curious neighbors, various civil servants, contingent passers-by, relocated and nesting birds, bats and cats, other builders, students (researchers), colleagues of all kinds. This site does not want to be merely a place for reflection-in-action as a dialogue between designer and design; instead, it wants to be a primer and stage for connections and possible controversies.

I have aspired to start drawing in these other actors, providing a stage for them. I have invited in the contributions of students; I have debated while building with neighbors; I have designed from the perspective of other-than-human actors; I have sought to make ambiguous the boundaries the studiolo shares with the city, allowing also for (at least temporal) occupations; I have aspired to provoke processes of making sense in those passing by. In short, in constructing the Research Studiolo, I have been working through fragments to engage with things that overcome architecture, with chance events and actors that affect its course, with controversies that entangle it. In this there is no preset order of things: fragments enter into juxtaposition with other fragments, thus edifying the architectural artifact.



Figure 2.51: The Hersenspinsel models, each representing a different fragment in the snow-crystal-morphogenesis of the Research Studiolo. Models and photographic collage: Joban Liekens.

10.1. A JUXTAPOSITION OF FRAGMENTS, CALLING FOR ACTS OF POESIS

—Hersenspinsel₀₁ and ₀₂—

I will start describing the Research Studiolo by advancing one of its constituting fragments. When describing the Walled House at the outset of Chapter 2, I stated that each project knows failures that are seldom communicated or leave traces. What intrigued me in particular was that, while the Walled House was prepared to have a productive—possibly conflictual—potential, subtly crafted into its flesh, that potential became partially erased. The house's working became less complex, less ambiguous, less resistant to a one-directional interpretation, less an embodying body. And, importantly, this failure was in no way articulated.

When starting to develop the Research Studiolo, I was confronted with a cosmetic erasure within the studiolo's immediate urban surroundings, similar to what had overcome the Walled House. Arguably, the similarity here hints at a defensive stance recurrently taken in the development of the urban tissue—that is, a policing and not a political development. Facing the Research Studiolo, on the other side of Ghent's Spaarstraat, there used to be an impressive public bench of polished concrete. As a border it mediated the relationship between the private garden of an office building (&Compagnie) and the adjacent public space of the street. That bench had an angular deployment between the two territories, its firm mass damming also a series of rectangular ponds with water lilies and grasses. The angular recession of the bench onto the private terrain and into the series of ponds coincided with a bus stop on this side of the street, while the parallel stop on the Research Studiolo's side had been eliminated some time before. The success of the large-scale public bench as a waiting place and an open-air extension of the former factory houses in front of it, could be measured by the precipitation of the various traces of use and abuse. Besides the fish fins and lips recurrently popping to the surface, some colorful parts of toys regularly stuck out of the water. Oily imprints of sunflower seeds'

Figure 2.52: The Research Studiolo's location in Ghent, in bright red the contour of the Research Studiolo, in dark red the original office space of STUDIOLoarchitectuur, and in thick blue lines the position of the public bench facing the Research Studiolo. Edited photograph retrieved from Google Maps.





Figure 2.53: The office building of *&Compagnie*, with the added cinderblock wall slightly emphasized by blue lines, as seen from the Research Studiolo's side. Photograph: Johan Liekens.

leftovers tainted the concrete surface after a warm day of sojourn. There were regularly Persian carpets hung to dry wherever possible. There were the resident ducks to feed. In short, the bench framed an intriguing and intense urban spot.

One day, the public life of the bench ended without warning when a brick wall was meticulously constructed on top, with aesthetically patterned pins sticking out of its upper surface (Fig. 2.53-59). A particular effort was made to seamlessly incorporate that addition into the overall architecture of the former bench and original building, as if it had always been there. Every trace of it was covered by the same lime wash covering used for the outer surfaces of the adjacent *&Compagnie* building. Curiously, in all photographic communications documenting this renowned project, only the version with the wall added can be retrieved.

The width of the walled addition not corresponding with that of the original bench, only half of the seat depth is left now and, curiously, it was left on the bench's inner and now publically unattainable side. This horizontal surface has no function now, since the pond here directly touches the concrete mass of the former bench. However, on the street side, in the middle and receding part of the wall, a small horizontal surface has been left as a remnant of days gone by—a halved-surface caused by the addition of a wall with half the debt of the original wall—on which visitors may try to sit (Fig. 2.57-59). The measures taken here echo similar measures and forces discussed in relation to ambiguous spaces such as Cuyvers's *Public House* (its opposition and destruction one night) and our *Walled House* (version constructed versus version designed). I cannot but associate the intervention encountered here with so-called defensive architectural measures designed to avoid all kinds of public occupation, which are increasingly applied to existing architecture.

Responding to the situation encountered, a first trait in constructing the Research Studiolo was to *add* to that situation a brickwork wall myself, copying the logic of the addition but counteracting that logic by designating that addition to be a contour enabling a new (semi-)public space to come into being. I started the design and construction of the Research Studiolo hence by clearing the ground floor of the studiolo's shell and adding to it a receding and open-walled contour with cinderblock

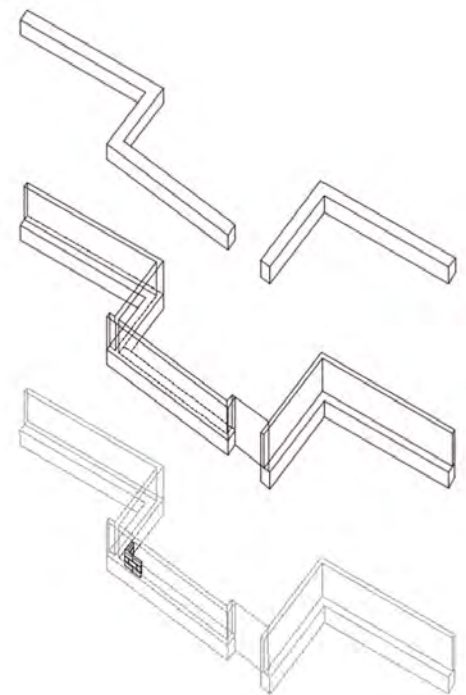

Figure 2.54: Drawing of *&Compagnie*'s original concrete bench (above), with cinderblock wall added on top of it, dividing the seating surface in two unusable halves (middle). Drawing: Johan Liekens.

Figure 2.55: Original concrete bench with cinderblock wall added on top, enclosing the former public garden. Photograph: Johan Liekens.



Figure 2.56: Aestheticized defensive measures for avoiding all kinds of public occupation on public benches. Photograph: J.L. Jahn.



Figure 2.57-59: On the walled bench as it is now, passers-by seeking to sit and rest or trespass. Photographs: STUDIOLOarchitectuur.

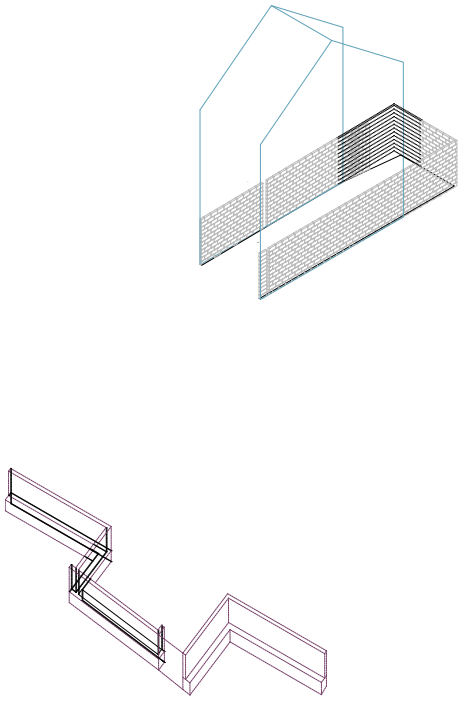

Figure 2.60: *Hersenspinsel₀₁* as the first fragment of the evolving, accumulative drawing of the Research Studiolo. Drawing: Johan Liekens.

Figure 2.61: Scale 1:1 drawing found within a receding wall section near the Research Studiolo's construction site. Photograph: Johan Liekens.



masonry (Fig. 2.60, 62-66). This contour can be read as defining a *waiting room*, a room awaiting temporal programs as well as occupations that diverge from mere private uses. It can enable a somewhat ambiguous relationship between the interior and the public sphere to come into being, an ambiguous stage that swells and dwindles. In connection to the street, the contour is left open. Outside of the existing façade and placed a small distance from it, a long steel folding gate is hung (Fig. 2.95). The gate can be present and enclosing, but just as much it can be absent by folding it in front of the existing wall post, fitting precisely to it. Whether the gate is open or closed, the Research Studiolo's façade and type diverges from its neighbors (Fig. 2.89, 95). At the same time, being one in a row of factory houses, it adopts some of the typological traits of this row of houses. This can, for example, be witnessed in the construction detail of the first floor window, which assembles the old position (according with the typology of the row of identical houses) and the new position (according with the contemporary program of the Research Studiolo) of that window. Each of them hence answers to a different and time-related logic, giving the façade a material depth that testifies of its assembled nature (Fig. 2.94, 95).

Instead of concise and comprehensive plans, what led to the construction of the open contour had been the welding of a small model from different alloys of metal, substantiating an idea I kept in my mind at that moment—the idea of adding a walled open contour. I called that model *Hersenspinsel₀₁* (Figure of the Mind₀₁). With the particular terminology of this model and of the models that were to follow, I wanted to give substance to the ephemeral nature of ideas (and events) substantiating and interplaying, of connections and collisions overcoming the research studiolo and those creating it. I also wanted to highlight the Research Studiolo's nature as an interweaving of fragments (the word *spinsel* in Dutch refers to the materiality of woven fabric). *Hersenspinsel₀₁* shows the basic form of a house—the exact form of the studiolo's shell—as in a child's imagination, adding to it the open cinderblock contour described above (Fig. 2.60). In parallel to making this model, which would become an ongoing method of model-making and giving form to the Research Studiolo, I started to draw an isometric view of the same basic and typical house form, adding to it the first fragment of the walled contour. This drawing would become the base of an evolving and accumulative drawing of the Research Studiolo's interwoven fragments, floating in one another's vicinity, a drawing made as an answer to the aforementioned Research Training Session exercise of portraying one's research (table).

Besides finding a motivation relating to the public bench's failure, early in the design process I stumbled upon a suggestive drawing near the studiolo's construction site. With simple chalk lines it depicts a resting body on a receding brickwork wall section. To me, basic drawings of that kind suggest the recognition of a certain potential for such occupations of architectural artifacts and their ambiguous articulations. By adding the open contour, I sought to resonate with this recognition, which is also a recognition of a desire or even need to occupy existing urban

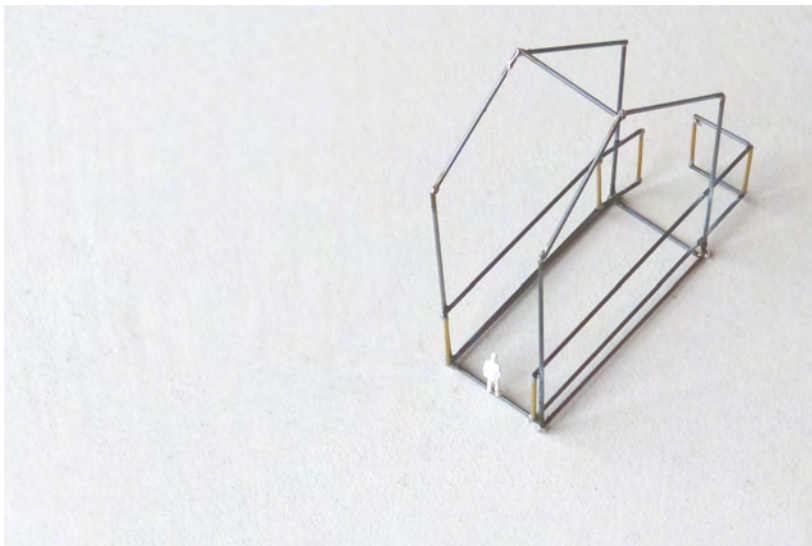
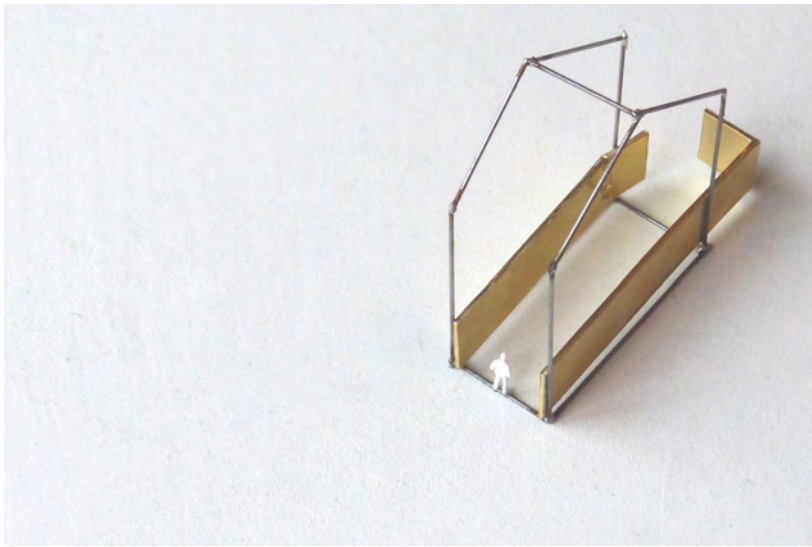
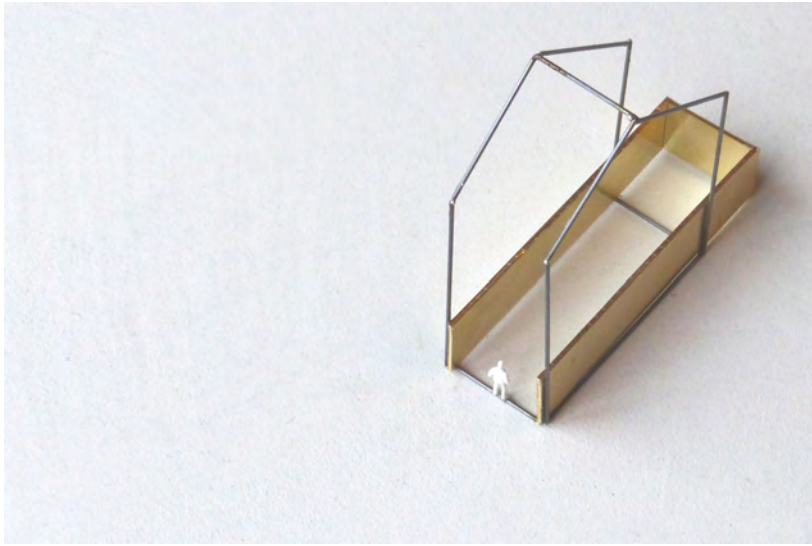

Figure 2.62-64: Hersenspinsel₀₁ substantiating the addition of an open brickwork contour to the general contour of the Research Studiolo's shell. Model: Johan Liekens.

Figure 2.65: Clearing the ground floor of the studiolo's shell. Photograph: Johan Liekens.

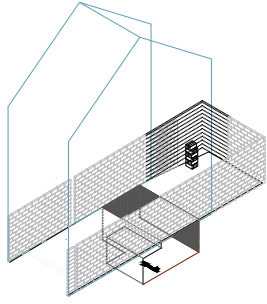

Figure 2.66-68: Constructing and detailing the open cinderblock contour on site, with specific attention to the detailing of fronts and angles (these constitute a separate Hensenspinsel, to be seen in the lower model). Photograph, model, design and execution: Johan Liekens.



settings.

Thus, as with the Walled House, the motif of the receding public alcove became present in the design. Its introduction was strengthened by a contingent discovery made on site while clearing the ground floor of the Research Studiolo's shell. When removing parts of the original floor, I stumbled upon a system of vaults and beams. Having carefully cleared the surface across, I started chopping out parts of the brickwork vaults, discovering underneath a forgotten cellar, positioned centrally within the house's overall footprint (Fig. 2.69, 71-74). The fragment of a sunken surface thus could be added to the project in the making, to its model and drawing, dividing the Research Studiolo's main area into three zones. Directly adjacent to the street, a (semi-) public surface was set apart from a private space in the back by means of the central sunken surface. The latter I conceived and constructed as a private studiolo, with a private alcove incorporated and positioned within the space of the cellar's original staircase. I meticulously detailed the sunken surface and private alcove in a formwork of roughly sawn wooden planking, in which concrete was poured, with the resulting surface carrying the imprint of the wood (Fig. 2.72-74). The same wood was used to detail the ceilings' claddings, making this roughly sawn wood's surface present as such but also as an imprint, constituting a unified material entity (Fig. 2.75). The masonry of the vault and beam system was reused to build some of the new walls within the overall construction, such as the new masonry within the frame of the first floor window (Fig. 2.94). This initiated a reshuffling of material. While the sunken surface will serve as a private studiolo and the surface in the back as an extension of our architectural office, the zone adjacent to the street I conceive now as a space with a potential for public occupations, as a public alcove or, better, as the aforementioned *waiting room* awaiting occupations of all kinds.



The above constructing actions coincide with $Hersenspinsel_{02}$, modelling the discovery of the sunken level as an important moment in the design process (Fig. 2.71-74). Also the accumulative drawing was altered in parallel, inscribing a resting body in the private alcove, and a similar resting body onto the surface of the *waiting room* neighboring the street (Fig. 2.69).

The fragments of cinderblock contour, of surface extending the architectural office, of sunken private research studiolo, of public waiting room—all of these would and will be combined en route with other fragments (other $Hersenspinsels$) in the development of the Research Studiolo. It is not important here to mention them all. The artifact, moreover, is still developing. More important is that the Research Studiolo's coming into being is conceived as a messy and accumulative construction drawing in reality, through making all kinds of connections and getting drawn into all kinds of controversies. I will explore some of the many other fragments, because accumulated they start to substantiate the artifact Research Studiolo. I will end by inserting the accumulative drawing in its current and unfinished state.

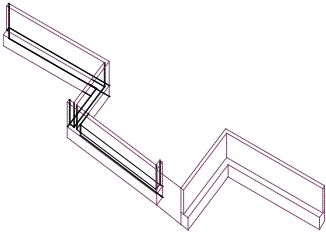

Figure 2.69: $Hersenspinsel_{02}$ as the second fragment of the evolving, accumulative drawing of the Research Studiolo. Drawing: Johan Liekens.

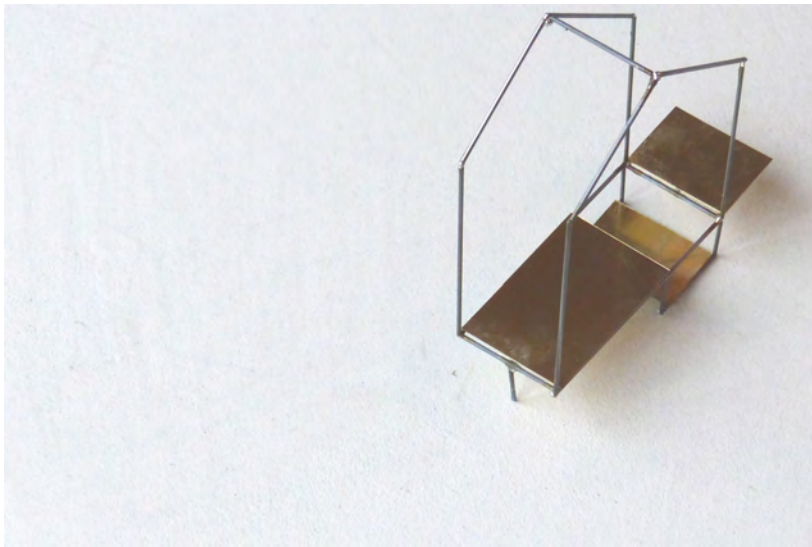
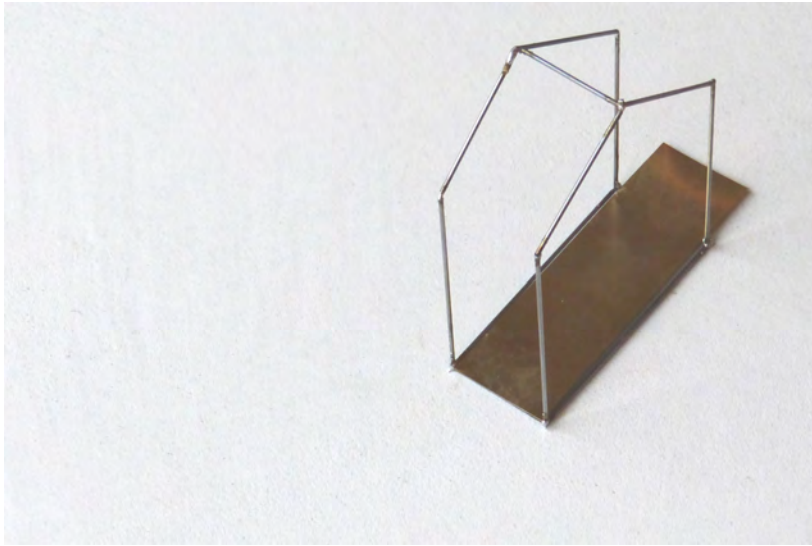

Figure 2.70-71: Hersenspinsel₀₂, with two separate models modelling the discovery of the sunken central surface as an important moment in the design process. Model: Johan Liekens.



Figure 2.71-73: The discovery of a former cellar and subsequent elaboration of a formwork of roughly sawn wooden planking to pour concrete walls with wood imprint. Photographs: Johan Liekens.





Figure 2.74-75: The sunken surface of the private studiolo with receding alcove (below right) and the open cinderblock contour (above), concrete with an imprint of roughly sawn wooden planking, which was re-used in turn for the ceiling above the sunken surface. Photographs, design and execution: Johan Liekens.

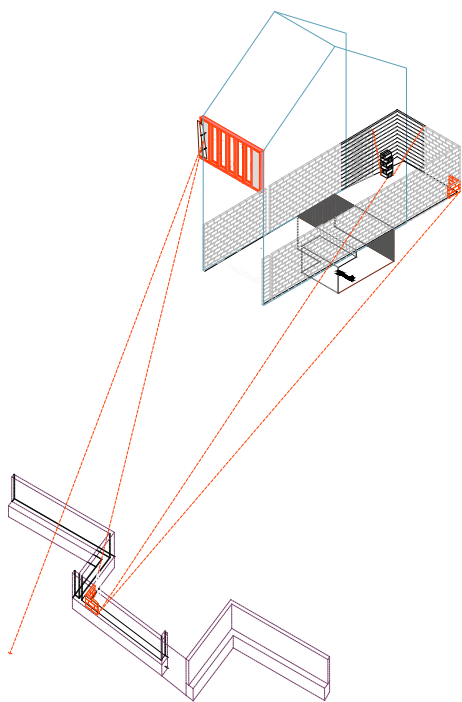

Figure 2.76: *Hersenspinsel₀₃*, as the third fragment of the evolving, accumulative drawing of the Research Studiolo. Drawing: Johan Läckens.

While constructing the walled contour I started thinking about locally restoring to the public bench its original width and thus some of its original functionality. I thought about adding another half-wall to the construction, as was done in the act that ended the bench's public life. I am currently developing a small corner object, conceived as a *simili* of a corner fragment of the Research Studiolo's walled contour, to be positioned (displaced) when finished within the angular recession of the former public bench (Fig. 2.81-84, 87-88). The corner object is made of poured concrete. As an object made in and according to the Research Studiolo's walled contour, it will, once displaced, show its familiarity—as a *simili*—with that contour, thus extending its spatial reach. In this way, the corner object assumes the walled contour's pattern and the heights of its joints, thereby making a connection between the two waiting rooms that face each other. Seated on this corner object, one will be able to glance back at the now-secluded garden, which one sits by but does not see, as a memento. For this, a two-way mirror will be mounted high on the façade of the Research Studiolo, in one of the windows at the side of the upper block-framed assembly that spans the width of the house (Fig. 2.80, 85, 89, 96). The mirror also echoes the mirrors of public surveillance one encounters as remnants within the city of Ghent (Fig. 2.86). For some reason or other, I have always been fascinated with such mirroring devices, though longing to use them in a different way.

The positioning of the retrospective mirroring device is not accidental. One of the first desires I wanted to respond to when conceiving the official program was to position a house-width window assembly high in the façade (Fig. 2.80, 85, 89, 96), opening a view on the garden across the street. While initially a permit for this was granted, the fire department stipulated in an appendix that the window lights on either side could not be of glass. I took this as a challenge, leaving the design of the house-width window as it was, with solid infill panels at either side, considering the two surfaces created thereby as spaces for small and particular (critical) inscriptions. One of these inscriptions, as suggested, relates to the seclusion of the former public garden and bench, by opening a retrospective insight in the formerly public garden, as a memento. The house-width window then frames two different views into the garden. The above design and construction actions are incorporated into *Hersenspinsel₀₃* (Fig. 2.77-80), and they have been added to the accumulative drawing (Fig. 89). Most important in the construction actions following *Hersenspinsel₀₃* is the fact that the two waiting rooms have been linked, that both extend their territory into the other, a swelling and a dwindling. Further, the corner piece is displaced into the public terrain as a tactile clue of the public space that has been destroyed and of which no trace is left.

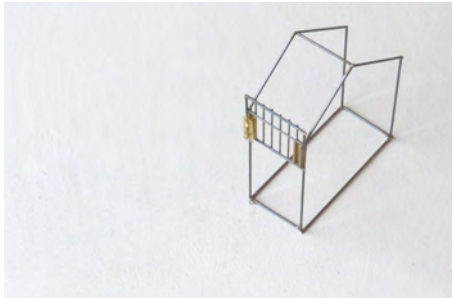
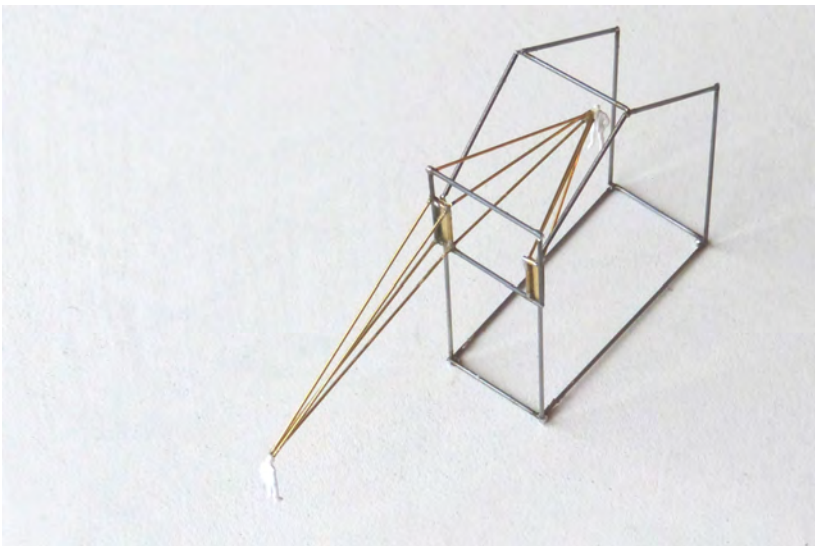
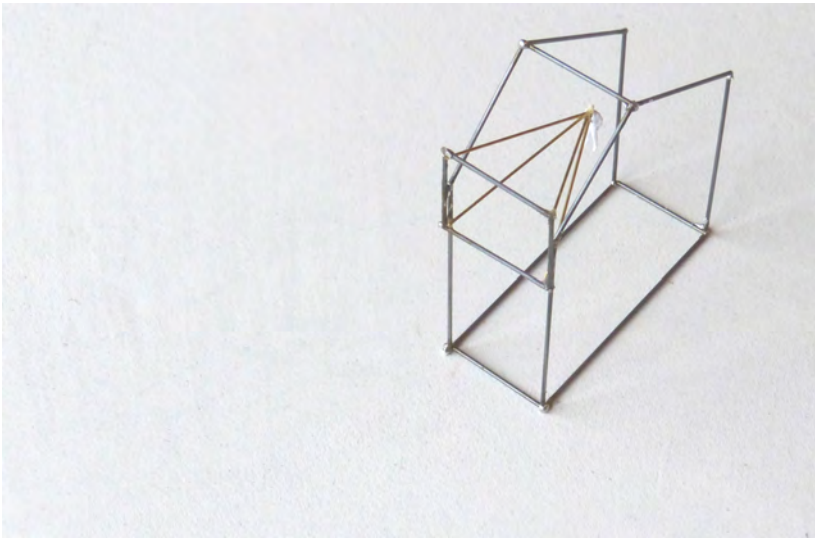
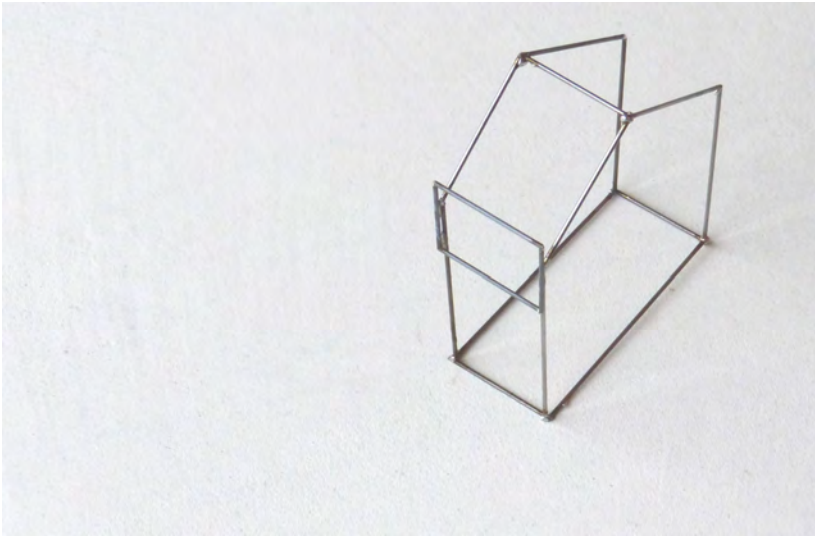

Figure 2.77-80: *Hersenspinsel*₀₃, four separate models modelling different views into the formerly public garden. Model: Johan Liekens.

Figure 2.81-84: Creating formwork and casting concrete for the corner object, imitating the back corner and cinderblock patterning of the Research Studiolo's walled contour, to be subsequently displaced in the public terrain, positioned in a receding angle of the former public bench. Photographs, design and execution: Joban Liekens.





Figure 2.85: Intermediate model of the Research Studiolo's façade. Model: Johan Liekens.



Figure 2.86: A surveillance mirroring device mounted high on a façade in Ghent. Photographs: Johan Liekens.

Figure 2.87: A glance cast back into the secluded garden, as a memento. Model: Johan Liekens.

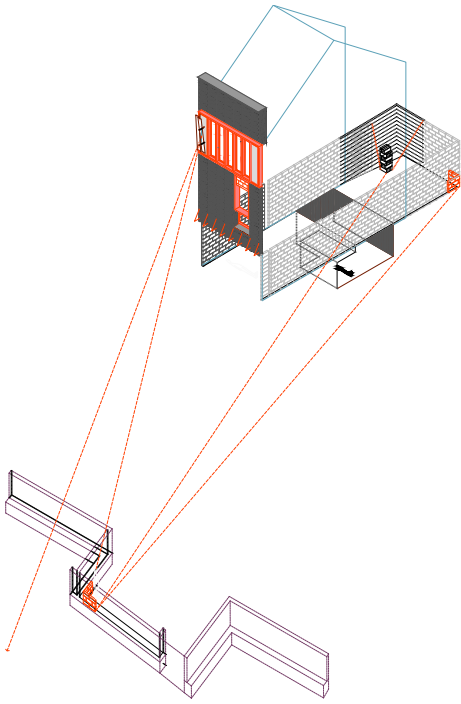

Figure 2.89: *Hersenspinsel₁₃*, as the thirteenth fragment of the evolving, accumulative drawing of the Research Studiolo. Drawing: Johan Liekens.

Figure 2.90: The existing façade of the house that will become the Research Studiolo. Photograph: Johan Liekens.



Skipping a variety of other Hersenspinsels / Figments of the Mind, which all are embodied in a separate model and part of the accumulative drawing of the Research Studiolo, I now move directly towards Hersenspinsel₁₃. This I do in order to show how materiality itself *follows* the *following* of the architectural artifact. In the process of pursuing an official building permit, I was confronted with an approval as well as a refusal, the latter stipulating that wooden cladding was unacceptable due to fire safety legislation. A period of discussions with the fire department and urban planning services followed, but no progress was made in the matter. After a long period of exploring alternatives, I stumbled on the seemingly contradictory technique of protecting wood from fire by fire, this is by means of burning (or rather charring) its surface. This technique adds to the surface a thin layer of protective charcoal, which resists catching fire and at the same time protects against weathering. Having explored the matter technically, I decided to start sawing, drying, profiling and charring the wooden cladding of the Research Studiolo's façade, using the same kind of wood I had used in the formwork for the concrete cellar and the cladding of the ceilings above. Here, a controversy over the use of wood for reasons of fire risk led to the integration of that risk—fire—in the construction process. The now burnt surface of the Research Studiolo, a scorched object, so to speak, hence tells through its rutted and blackened materiality still smelling of fire a part of the narrative of its making. The materiality was not planned in advance; it relates to aleatory conditions affecting the artifact. The shear materiality and the experimenting, done mainly in the street in front of the Research Studiolo, effected a multitude of conversations with some neighbors and passers-by, resulting in some surprising conversations on architectural design.

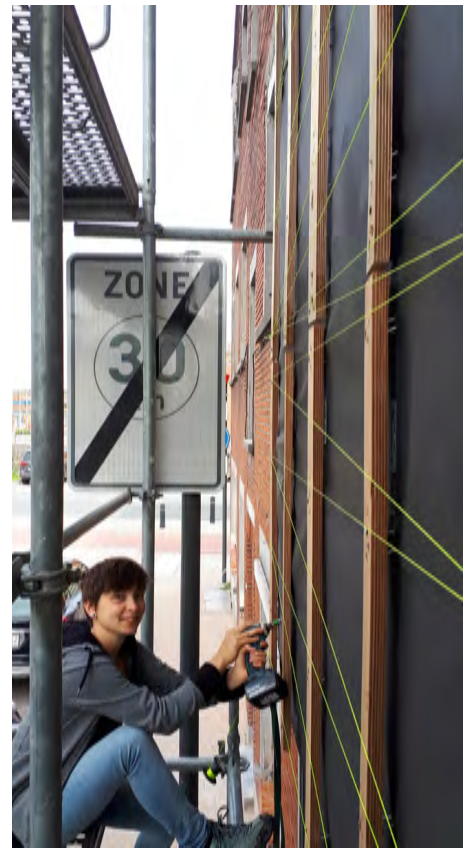

Figure 2.91-94: Front façade of the Research Studiolo, preparing the structure for and charring the wooden cladding, with some help of the former CoMa/ CoIn student and STUDIOLOarchitectuur intern Mirte Van Aalst. Photographs: Joban Liekens.



Figure 2.95: Front façade's first-floor window, with wooden block frame following the typology of the neighboring factory houses, while the masonry structure in the depth of the window accords with the contemporary program of the Research Studiolo itself. Photograph: Johan Liekens.





Figure 2.96: Front façade of the Research Studiolo with burnt wood cladding, wooden block frame windows and folding gate. Photographs, design and execution: Johan Liekens.

Figure 2.97-98: Surface aspect and weathering of the wooden cladding. Photographs: Johan Liekens.

In the time span of constructing the Research Studiolo, fragments were also articulated by connections made to other research contexts and projects. In the following section, I explore two such connections. The first connection is one that emerged in the framework of the Swedish Research School in Architecture (ResArc) in conversations and collaborations I had with Brady Burroughs and Thierry Berlemont, two of the participating researchers.

While constructing specific parts of the Research Studiolo, such as the cellar and the roof, I was sometimes in the company of animals more than in the company of people. Mixing the concrete for the sunken studiolo's walls, I was accompanied for a week by a lost cat that had sought shelter in the permeable construction that constituted the Research Studiolo at that time—and still does. During the daytime, she followed the process with curiosity, even imitating the circular movements made by the mechanical concrete mixer in the mingling mass of concrete. In the evening, the cat and me went for walks after work, knocking on doors to find the cat's owner. One morning, climbing onto the roof, I found myself in the company of a heron staring statically back at me from the house's ridge (Fig. 99). There was the discovery of seasonal nesting places of bats and great tits, resting behind the plastic claddings of neighboring houses and within the fissures of cavity walls. There was a pair of doves that made the scaffolding I had positioned at the rear façade of the Research Studiolo into their temporary home (Fig. 2.101). Each of these inhabitations by city animals caused in their particular way a slowing down of the construction process. Aside from these accidental encounters, there was over the years the constant presence of one and the same crow calling from the chimney of our house, a crow I came to name Rik (Fig. 2.100). I had long conversations with Rik when constructing the outer shell (roof, rear and back façade) of the Research Studiolo. Rik negotiated with endurance his own presence in the future project. Because *his* chimney needs to be abolished, as it contains asbestos, I am planning to copy the old chimney and slightly displace it as his new-old home (Fig. 2.115). I also envisage other articulations for Rik and his fellow creatures.

While I was starting to construct the Research Studiolo's outer shell (roof, rear and back façade), I was reading a text by Berlemont and discussing it with him. I stumbled upon a photograph he had taken of a façade clad with concrete tiles, placed neatly in a diamond pattern. The tiles were slightly weathered, causing a greyish deposition on their surface. In front of the façade were some bushes that had grown close to the façade's surface, delivered to the play of the winds. As a result of that situation, the material, the wind, and the ongoing scrubbing of branches, a beautiful drawing was in the midst of being etched on the surface of concrete tiles. By coincidence, at that moment I was also thinking about the materiality of concrete tiles, placed in such a diamond pattern. There were several reasons for this.

A first reason related to my desire to make the outer shell inhabitable in a variety of ways. I already mentioned the waiting

Figure 2.99-101: The Research Studiolo's resting heron, nesting pair of doves, and inhabitant crow Rik. Photographs: Johan Liekens.



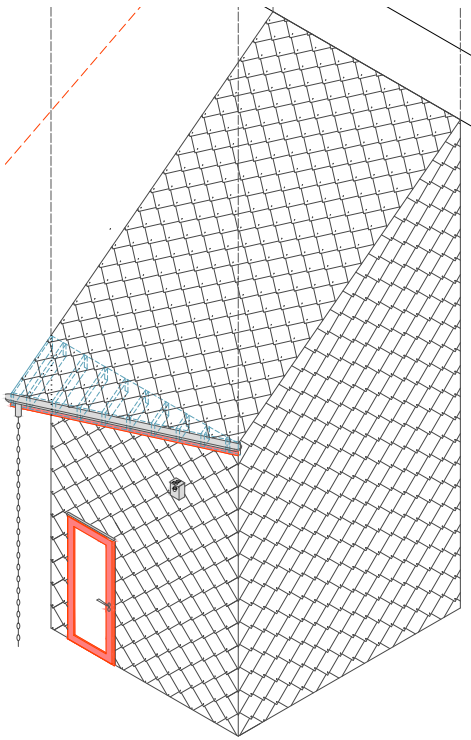

Figure 2.102: *Hersenspinsel*^{17,18} as the seventeenth and eighteenth fragment of the evolving, accumulative drawing of the Research Studiolo. Drawing: Johan Liekens.

room awaiting programmed as well as contingent occupations by people. But, as suggested, I also wanted to *follow* the actions and inhabitations of the many non-human agents connecting to the Research Studiolo. I had found a firm specialized in the construction of concrete nesting stones for great tits and bats, two species I regularly encountered when constructing on site. I studied the orientation of the building in function of their ways of inhabiting, and found that the east (rear) façade, if protected from rain, would be a fitting place for housing families of great tits. The west façade, in turn, was suited for a colonization by bats. Thus, I started integrating the solitary nesting stone for great tits into the rear façade, partially embedding it in the insulation layer I had mounted onto that façade (Fig. 2.102-103). The nesting stones had a brutalist nature; they were just what they were. However, I had to add to them a zinc roof cover in order to protect them from infiltration by rainwater. I started seeing the Research Studiolo itself as a scaled copy (again a *simili*) of the nesting blocks from seamless concrete covered with a slightly overhanging roof. Here the material of concrete tiles placed in a diamond pattern came into the picture for the first time. These tiles are ideally suited for corners where three planes of a volume join one another, as is the case in the Research Studiolo, where roof, rear façade and side façade meet on one corner. With the material and patterning of the tiles, one can form a continuum stretching over the edges of a building volume (Fig. 2.107). Above, the rear façade the roof protrudes as a substantial overhang, a scaled copy of the zinc roof cover over the nesting stones (Fig. 2.104). The overhang is not solely an aesthetic feature or an idea in relation to the detailing of the nesting stones; it also functions as a rain cover over the unique door in the rear façade, giving entrance to one of the staircases of the building. Another function it assumes is that, by its protrusion, it gives definition to the terrain's limits, putting the volume of the Research Studiolo slightly apart from the other row houses, and thereby assisting in the creation of a somewhat enveloped inner set of roof gardens. The overhang also drains the rainwater falling onto the roof to the gutters in a specific, visible and thus present way. When it rains, the pouring down of water is accentuated and has its play within the inner gardens.

The poetics of the accumulating of traces going on in Berlemont's picture I associated with a technical aspect of the tiles themselves. Whenever these tiles are placed without wearing gloves, the imprints of fingers and pressure from the palm of the hand are perfectly ingrained into the material. Their presence reveals itself over time and through the working of humidity (rain, dew, etc.). Instead of preventing that from happening, I and those helping me at that time deliberately avoided wearing protective gloves. The drawing that was thereby produced shows a multitude of actions and hands, each with their unique imprints. It shows, so to speak, and recapturing Rossi, a moment of energy in the emergence of the Research Studiolo..

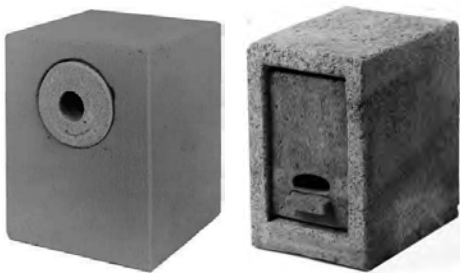

Figure 2.103: Prefabricated concrete nesting stones for great tits and bats. Photographs: Schwegler.



Figure 2.104: The Research Studiolo's rear façade, detailed as a scaled version of the nesting stones it contains. Photograph, design and execution: Johan Liekens.

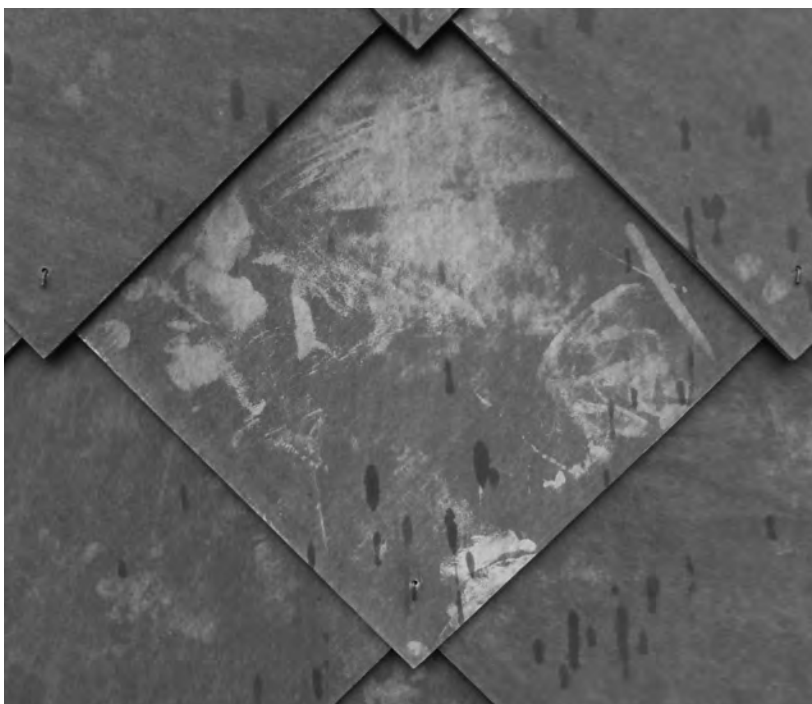

Figure 2.105: Concrete tiles on the weathered surface of which a drawing by wind and scrubbing branches has deposited. Photograph: Thierry Berlemont.

Figure 2.106: Concrete tiles on which the traces remain of the actions of the hands that put them there. Photograph: Johan Liekens.

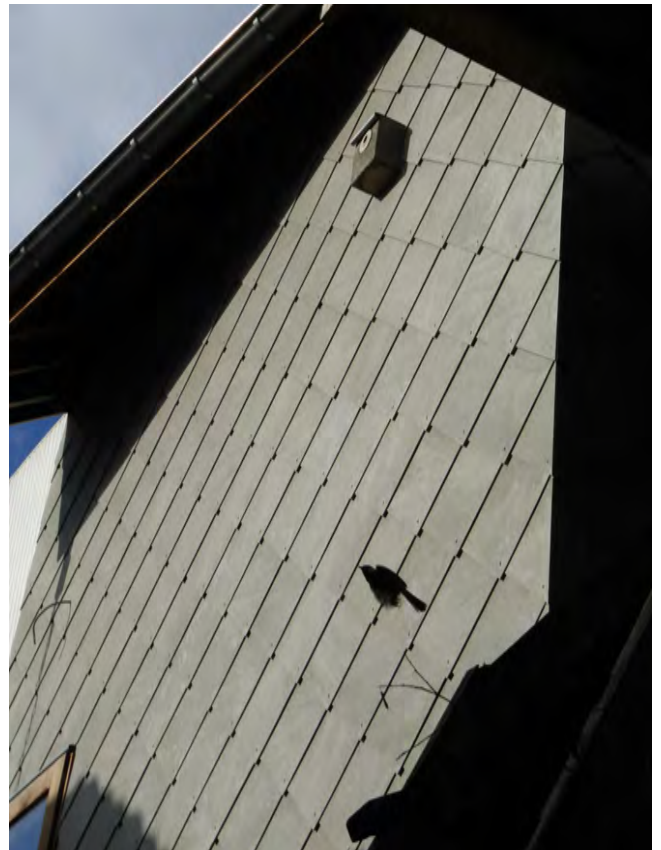
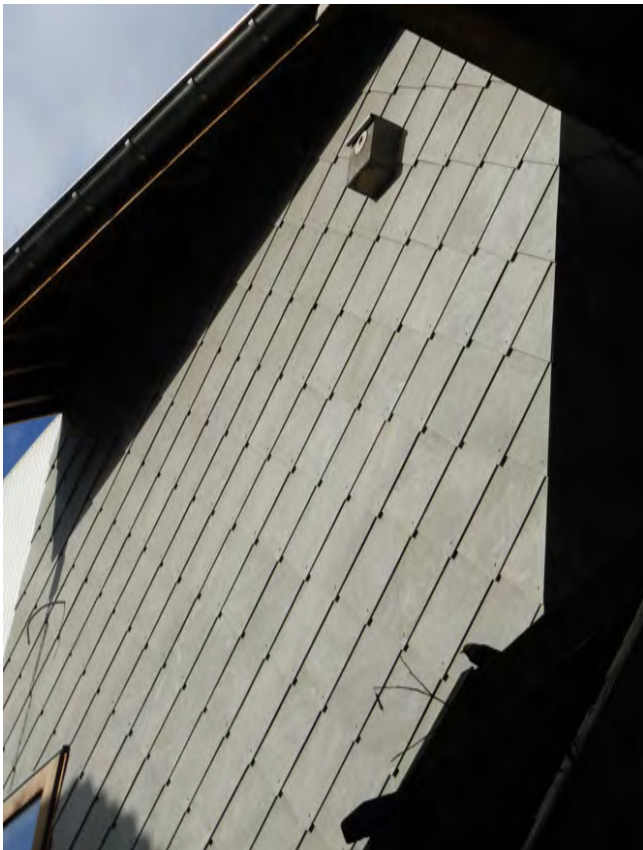
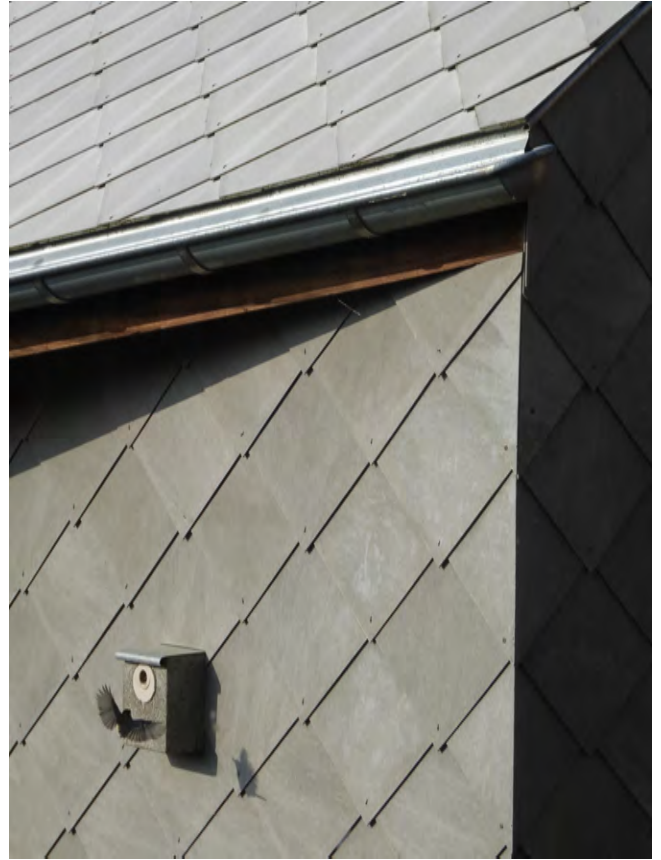
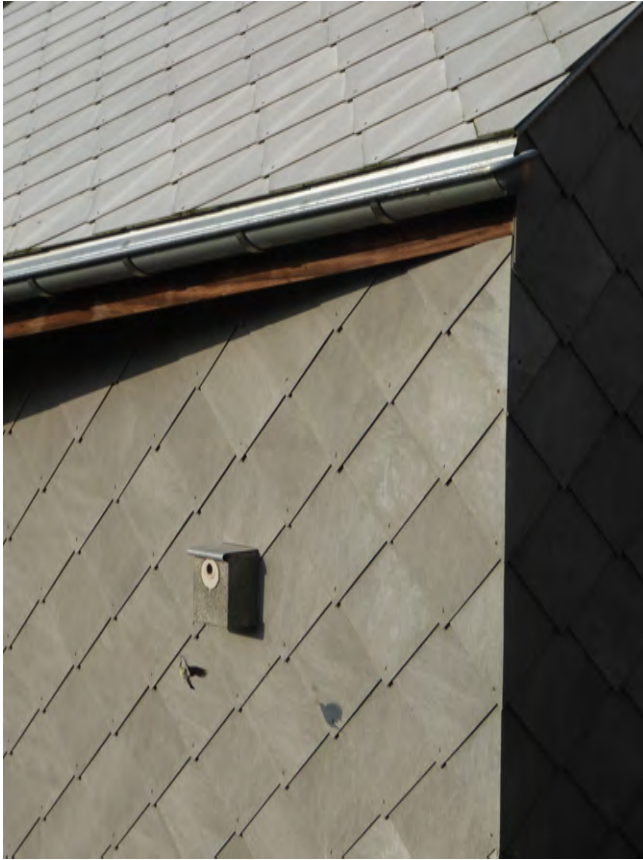

Figure 2.107 (series): Constructing the Research Studiolo's outer shell, joining roof, rear façade, and side façade to arrive at a quasi-seamless volume, imitating the nature of the nesting stones inserted in it. The important overhang imitates the roof cover of the nesting stones but also protects the entrance to the roof garden and defines its limits by protruding from the neighboring row houses. Photographs, design and execution: Johan Liekens.

In the spring of 2019, just after its completion, the outer shell became inhabited. During a period of four weeks, the inner garden and back of the Research Studiolo served as a bustling stage for an industrious pair of great tits, culminating in the fantastic moment of five youngsters flying out of the nesting stone, a moment I registered from my writing desk (Fig. 2.108, series).



*Figure 2.108 (series): The Research
Studiolo's concrete shell and nesting stone,
as a stage for the first family of great tits.
Photographs: Johan Liekens.*







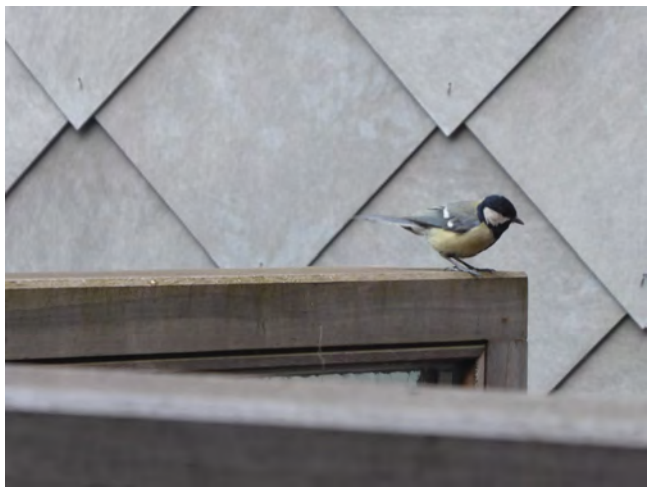









Figure 2.109: *La Finestra del Poeta a NY*.
Drawing: Aldo Rossi.

I had another set of conversations during the ResArc courses with Brady Burroughs. In one of the drawings of her dissertation, she foregrounds a detail drawn within the framework of her dissertation for a renovation of Aldo Rossi's Case Unifamiliari. The detail, called the Birdbath, comprises an abstract hand of San Carlone (a saint who figures regularly in the work of Rossi; see Fig. xx) in perforated sheet metal, with an acoustic mirror inset into the palm. The hand is hinged to an existing window, enabling it to be moved in front of the window, thus bringing it in sight of the interior. Onto the vertical acoustic mirror a horizontal birdbath is mounted to welcome the variety of birds passing by. Once seated on the edge of the bath, the bird's murmurs are projected into the interior, where they keep a lonesome dog called Hugo company. I intermingled this detail with some of the details taking shape in my own mind at that time. I already mentioned that in the emergence of the Research Studiolo two specific surfaces had substantiated, part of the wooden block frame of the house-width window in the front façade. As I said before, one was used to inscribe a mirroring device, a retrospective on a now-secluded garden. The other I intended to use to give a particular expression to the fact that the Research Studiolo drains the rainwater from an entire row of identical factory houses, a running mass of water that is usually meticulously hidden from sight and knows no function. I had been having interesting conversations with Thierry Berlemont at that time on the absurdity of architectural practice striving to erase from sight as many *invisible* phenomena, such as the draining of rainwater, as possible. Combining the above, I am now sculpting a copper bird bath, fit between two finger-like wooden beams that stick out of the Research Studiolo's front facade, the bath connected to and fed by the copper drainpipe, which then enters the building through that second surface of inscription. Thus, a birdbath will interfere with the splendid view one has from the interior onto the secluded garden.

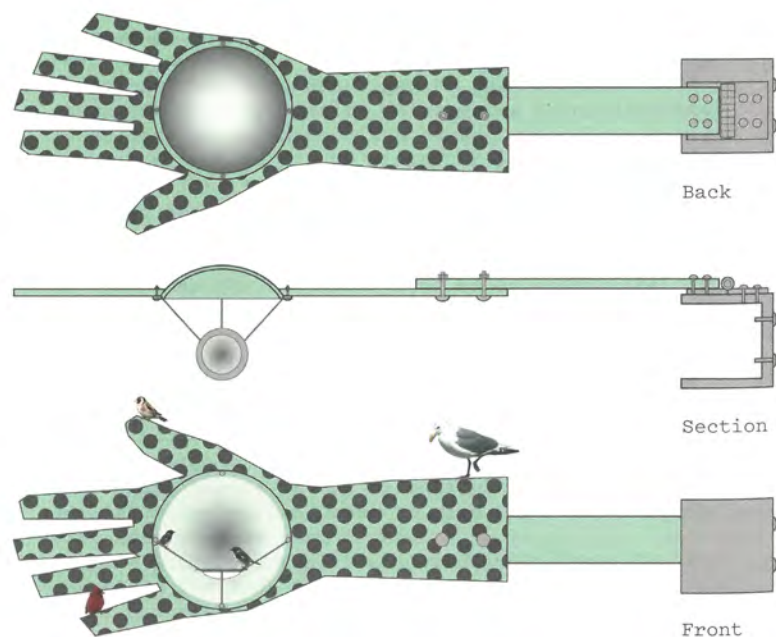

Figure 2.110: *The Birdbath*. Drawing: Brady Burroughs as Henri T. Beal.

DRAWING: HENRI T. BEALL (NOT TO SCALE)

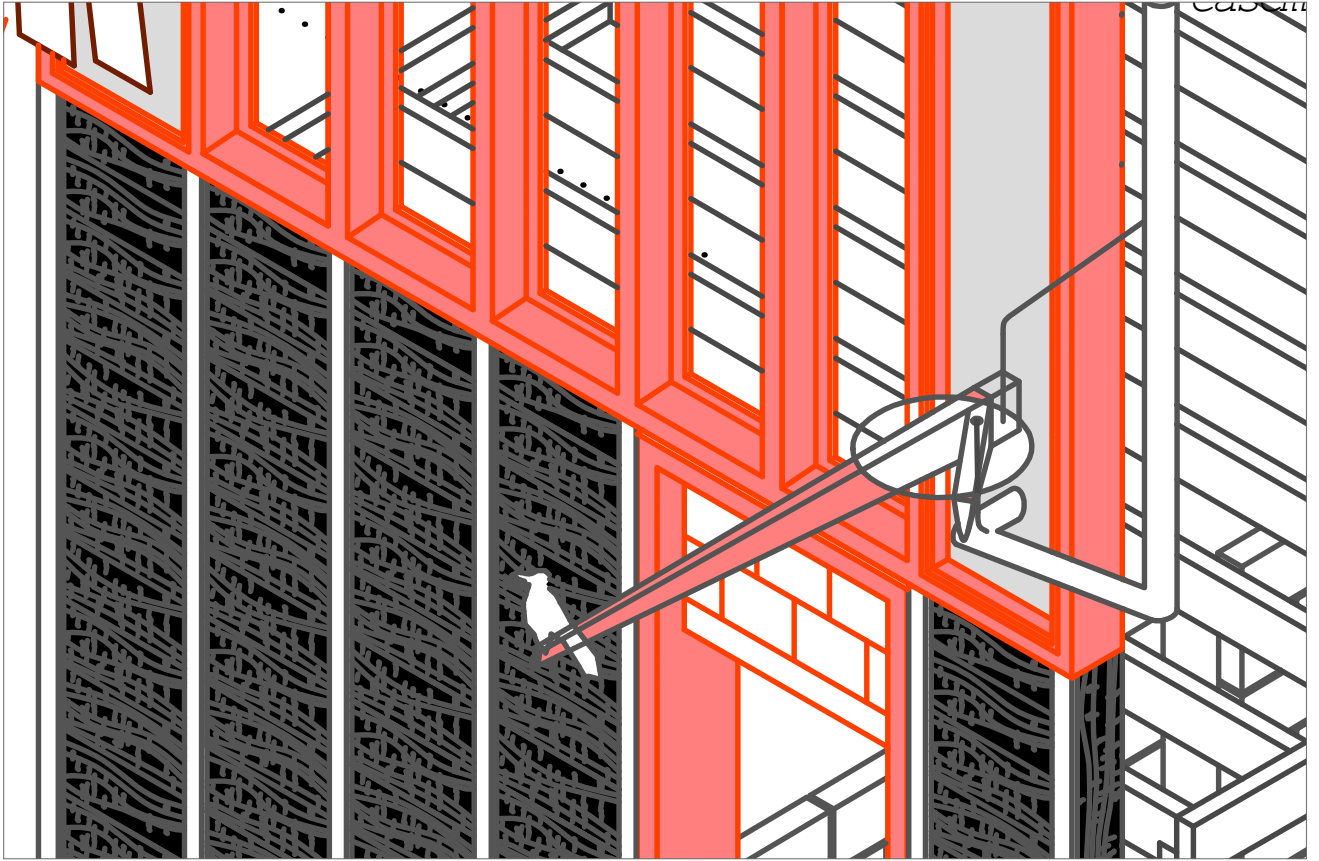

Figure 2.111: Hersenspinsel₁₈ as the eighteenth fragment of the evolving, accumulative drawing of the Research Studiolo, showing a birdbath for Rik and friends, interfering with the splendid view of the secluded garden. Drawing: Johan Liekens.

— still many other connections and fragments to come —

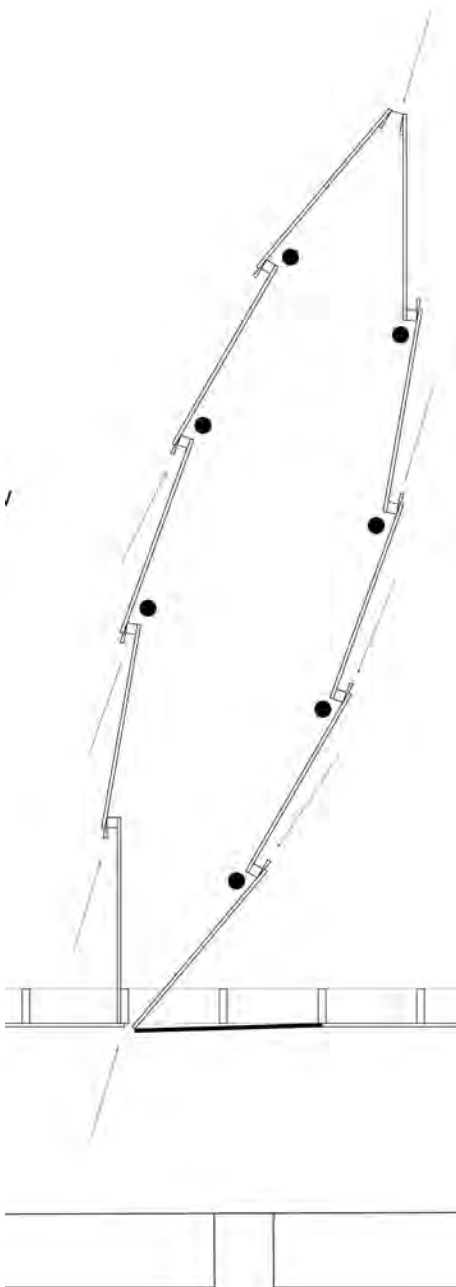

Figure 2.112-113: *The Cabinet of Sonic Gazes*. Photograph & drawing: Lucia D'Errico and Johan Liekens.

Many other connections have been made and are still being made, resulting in other fragments to be added. In 2016, within the framework of the Joint Doctoral Seminars organized by the Belgian Research Centre for Art and Architecture, I connected the construction of the Research Studiolo—as an artifact and a process—to the work of musician and researcher Lucia D'Errico. We explored and discovered similar ways of working, though in different artistic realms. Our collaboration was based on the idea that musicians and architects both use plans or notations that put in tension the consistent a priori plan (as a score) with the inconsistencies and contingencies by which musical and architectural spaces are produced in real time (physical enactments), while also actively drawing in an audience of other interpreters.

We worked on a common installation entitled *The Cabinet of Sonic Gazes*, in which we connected work D'Errico was doing in the realm of musical performance and research, and work I was doing in architecture. The aforementioned *hersenpinsels* were combined in the cabinet with aural fragments D'Errico had isolated (and interpreted) as single traits from a prelude by Robert de Visée. One could only catch a glimpse of the models lighting up through a series of ten small fissures that characterized the cabinet. The fissures, pushed open by sets of wedges, had deformed the original cabinet's form as a freestanding walled construct placed diagonally across a space, thereby creating an interior between the two sides of the wall. Our walled construct was positioned at an angle to a freestanding wall made of a basic wood framing and reflective panelling, already present in the space we were granted, a remnant of a previous installation. Our walled construct simply doubled the existing one in terms of construction and material. One of the existing wall's panels stood out strangely when we first visited the exhibition space, revealing the interior space within the wall. We copied this logic as well through the addition of wedges to spread the new panelling apart and create the aforementioned small fissures opening onto an interior cabinet. Together the two walls compelled visitors entering the space to walk around the installation in order to discover it, the space it was inscribed within, and the space it inscribed. We left open the space created by the two wedges that dilated each of the joints between panels, while the cracks above and beneath we meticulously closed by means of recessed panels. Thus, we turned the wall cabinet into a resonance box, with hearing and viewing positions on the level of the visitor's ears and eyes.

By pressing an ear to the cabinet's vibrating skin, one could more clearly hear one of the aural fragments playing quietly in an ongoing loop, sounding somewhat isolated from the murmur of other fragments in the background. We did not offer a direct look at the *hersenpinsels* either, instead using mirroring devices that indirectly reflected the models, lighting up against the blackened interior of the cabinet. Exploring the wall cabinet bodily, by bending and pressing the ear or eye to its surface, one could only



grasp clear fragments embedded in a dimmed accumulation of other fragments, inviting one to further explore the other fissures, leaving it up to the visitors to connect the fragments into an imaginary whole. Thus, the cabinet substantiated the conceptual approach that characterizes the constructing activity of both the Research Studiolo and some of D'Errico's de-composed and re-composed sonic spaces (video and aural fragments; see <https://www.researchcatalogue.net/view/278529/385681>).

Another connection I have programmed in 2018 and 2019 has been the embedding of two CoMa/CoIn design studios in the construction of the Research Studiolo. Of the performances that have taken place in that framework I add just one photograph.

My curiosity is currently drawn to the further elaboration of the interior of the *waiting room* that, as an extension of the street, awaits a variety of contingent occupations. At the end of my research here reflected within this thesis, the challenge lies in designing that next fragment and those next connections. Ending this Chapter 2, which developed around some walled artifacts, I introduce the accumulative drawing of the Research Studiolo in its current and unfinished state.

Figure 2.114: The Complicating Machine for qualitatively wasting time. Photograph: Group CoMa/CoIn 2018.



CHAPTER 2, IN A NUTSHELL

With Chapter 2 I shifted the experimenting ground of *Architecture's Poetic Instrumentality* toward professional architectural practice. This was done for multiple reasons, such as an intent to slow down architecture, taking into account the messiness of its production, and emphasize on its reception in a state of distraction, so that it would reveal a productive strangeness only throughout use and occupation. The architectural artifacts of Chapter 2 were *prepared* accordingly in the realm of conception.

A variety of walled architectural artifacts was designed, intending to deploy and explore their agentic capacities and aesthetics within urban surroundings. The pragmatic way of working that was thus deployed was associated with a reintroduction to architecture of a political and ethical capacity. One aspect of the political that was more clearly advanced in the exploration is the fundamental difference between policing and political politics. Close to the artifacts a variety of authors was visited, connecting to their thinking on and theorizing of the agency of artifacts or objects. In this exploration, the deployment of architectural intelligence and the idea of situated knowledge were favored over the idea of objective architectural knowledge.

In the exploration, the simple question whether there are ethics in the brick or composition of bricks served as a point of entry, to explore subsequently human-centered accounts of architectural (spatial) agency and *more-and-other-than-human* accounts of it. In the process, architectural artifacts were figured as stages able to probe socio-spatial situations, provoke thought and action, and (help) produce themselves change within these situations. Artifacts were rendered as able to raise claims, to allude and allure, to challenge and be vibrant, to be resistant, complex, and ambiguous. Artifacts foregrounded as messy and heterogeneous assemblages and constructions in- flight, growing along sets of connections, events and controversies. All these aspects were not only touched upon in theory, but substantiated first and foremost through the development of the artifacts deployed in this Chapter 2, from their design over their deployment to their reception or occupation. Throughout Chapter 2, the role of architectural matter and articulation in the above accounts of architecture was narrowed down on.

*REFLECTIONS
ON CONTRIBUTIONS*

REFLECTIONS ON CONTRIBUTIONS

In conclusion, I wish to elaborate on the contributions my research project makes, while also addressing the inevitable question of what can be considered its contribution to knowledge. I wish to emphasize *how*, *where* and *to whom* the research makes its contributions.

With regard to the idea of contributing to knowledge, I wish to reorient the idea toward the notions of “architectural intelligence” (Awan, Schneider & Till, p. 39; Till 2009, p. 167) and *situated knowledge*, both touched upon in Chapter 2. Architectural intelligence, as has been said, is typically practiced *within* situations. In my research, it characterizes the architect’s designing and intervening in specific socio-spatial situations by *preparing*, *arranging* and setting out urban architectural artifacts so that they (can) have a *transformative*, *poetic* production. Just as much, it characterizes those using, encountering, experiencing, and making sense of these inscriptions of artifacts and practices, in that way probing the urban as a socio-spatial phenomenon at local points. Sense-making in the form of *urban poesis* here is fully considered a making practice itself, producing situated knowledge on the many in-habitations of the city. The artifacts populating this thesis invoke such encounters and such sense-making processes more than many other urban artifacts because they are consciously *prepared* to do so.

In these processes of sense-making, both architect and *user* are called upon to pair the practical with the imaginative, a pairing that also marks the complicating machines and interiors (Chapter 1) and the walled artifacts (Chapter 2). More precise, these all have intended to deploy the practical as a stage for imagination to take off. The pairing of and tension between the practical and the imaginative is identified by Roberto Mangabeira Unger as one of the very conditions for producing *change* (Unger 1987, p. 308). This connects to Awan, Schneider, and Till’s view that in developing architectural intelligence it requires spatial agents to be “at the same time realistic and visionary” (Awan, Schneider & Till, p. 39). It should be noted that change and transformation as general terms in my research are interpreted as the development of new thinking and acting, unfolding *within* situations and amidst the articulations and on the stages of architectural artifacts. They are interpreted as a making *new* sense of such situations—as a way of understanding reality differently and hence as a way of producing new knowledge about reality (constructing alternative realities, revealing latent realities).

Relating to the artifacts and practices of my research, there is the loaded conjunction not only of the practical and imaginative, but also of the usual with the estranging, the consensual with the dissensual, the aesthetic and pragmatic with the ethical, the spatial with the social, and so on. With regard to the last of these, Till argues that “social relations are embedded in spatial relations” (Till 2009, p. 167), loading architecture with a particular ethical potential. Through spatial productions and projects and by addressing the imagination (of the designing

architect as well as the one encountering architecture), throughout use and experience architecture can help change and ethically re-figure reality. It can re-partition the sensible in that reality. Such re-figuring activity, invoked through architecture, happens by addressing and deploying architecture's critical, political, and ethical capacity, which I set out to explore. It happens by conceiving and subsequently deploying architecture as a probing, provoking, and poetic instrument.

Emphasizing the deployment of architectural intelligence of both architect and user here, contrasting it with the production and application of propositional knowledge, less solidified instances and *ways of knowing* are given a central position and rendered valuable. Besides substantial material artifacts, my research in that sense substantiates certain approaches, strategies, and attitudes that are somewhat fluid and situational themselves. I recapture them here:

- The relevance of and need for developing *ways of doing* architectural education and practice *otherwise*. In my research I followed, developed, and practiced such *other ways*.
- The relevance of and need for developing in architectural design (students) *ways of wielding a critical questioning design attitude inducing the dynamics of negotiation*.
- The relevance of and need for setting up in architectural design (students) other *ways of conceiving of architectural aesthetics* (aesthetics of use, aesthetics of politics, more ethical aesthetics).
- The relevance of and need for developing and deploying through architecture *productive forms of dissensus and agonism, of conflict and political negotiation*. I proposed a strategy of *agonistic staging*, answering to an outside call to help give substance to the theoretical concept of *agonism*, considered as an essential productive force in producing (democratic) reality (democratic public space).
- The relevance of and need for developing *ways of installing an architectural time of suspension*, referring to suspense but moreover to a suspending of a crystallization into definite meaning. Such suspending hints at the importance of approaches, strategies, and attitudes that induce processes of *negotiation* and *sense-making*. For this, as part of my research, I have crafted the *stages*.
- The relevance of and need for developing and deploying *practical approaches* (by project) to architecture that are inseparably bound with the imaginative, the social, and the ethical.
- The relevance of and need for developing and substantiating ever more *ways of thinking* not only about architecture and architectural artifacts but about their *agency*, giving them an ethical orientation outside themselves.

- The relevance of and need for using and developing other *ways* of conceiving of architectural matter. A *challenging materiality* that underpins the idea of the agencies of architecture as a practice and as an artifact. A materiality that allies with architecture's often contingent adventures.
- The relevance and need for developing and deploying *ways* of small-scale, local, and *acupuncture-like intervening* in urban environments, with (wider) transformative aims. Acupuncture here is seen as a modelling activity able to produce (systemic) change (see also Dyrssen 2017, p. 182-83).
- The relevance and need for variants of architecture that move *slower*, by developing and deploying *ways* of doing architecture that take in the messiness and multiplicity of architecture's genesis and ongoing development, that span the realm of conception and reception, that blur the boundaries between design and construction.

The list here is not limitative and many of the *ways* listed above relate to ideas and practices already advanced by others, as accounted for in this thesis. However, by developing and deploying architectural artifacts I have given—in collaborations—*specific* substance to such *ways*. For some existing ideas and practices I have developed *variants*. I think here, for example, of Yaneva's method of *following architecture*, a method for which the Research Studiolo develops an active variant. Similarly, Mouffe's concept of *agonism* is activated as a *agonistic staging* in some of the complicating interiors and walled artifacts, answering her call to do so. Notably the Walled House as designed and complicating machine CoMa₀₂ have materialized such stages.

The above *ways*—the above approaches, strategies, and attitudes—not only constitute a discourse for my research. They can be practiced by other practitioners too (architects, students, researchers in the field of architecture and other artistic fields). Adding to this, through the design and construction of architectural practices and artifacts the ideas of my research have literally gained *substance*, and can now be encountered in the reality of the city. In my research I have not followed a logic of merely translating and recomposing ideas that were harvested somewhere else (e.g. from existing discourses or practices). Instead, the designing and constructing activity at the center of my work has often itself produced thinking and sparked ideas, which are usable and ally with *outside* discourses and practices, further developing these. Then my research's contribution must also and importantly be situated within the architectural artifacts themselves, designed and constructed in such ways that they function as its main propellants. To the above list compiling a variety of *ways*, a simple list summing up the most important artifacts of my research must then be added, as a contribution in itself:

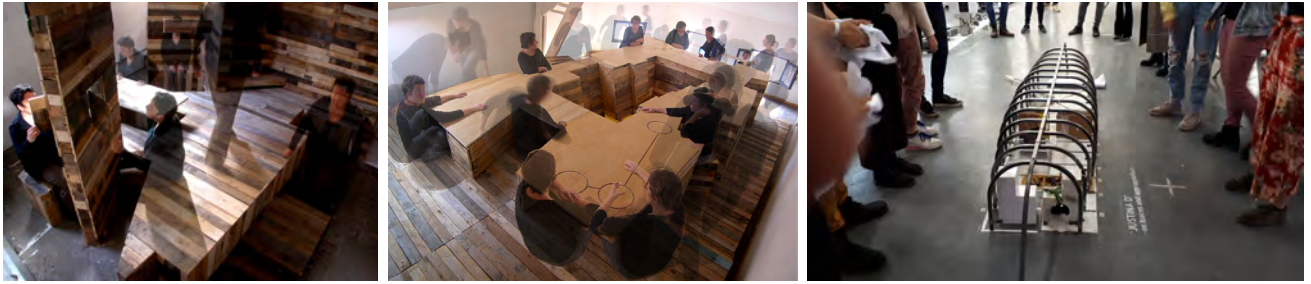

*_ produced within the experimenting ground of the educational practice that is the research-by-design studio
Complicating Machines / Complicating Interiors:*

- _CoMa₀₁, Ont-moetingsmeubel;*
- _CoMa₀₂, (Con)Fusion by Cooking;*
- _CoMa₀₆, Waiting Room of the Research Studiolo;*



_ produced within the experimenting ground shared in the architectural practice of STUDIOLOarchitectuur:

- _the Walled House project, and the kindred projects with familiar interests and aspirations:*
- _the Hogeweg Cornerhouse;*
- _the Harduwijnlaan Cornerhouse;*
- _the Spadestraat Rowhouse;*

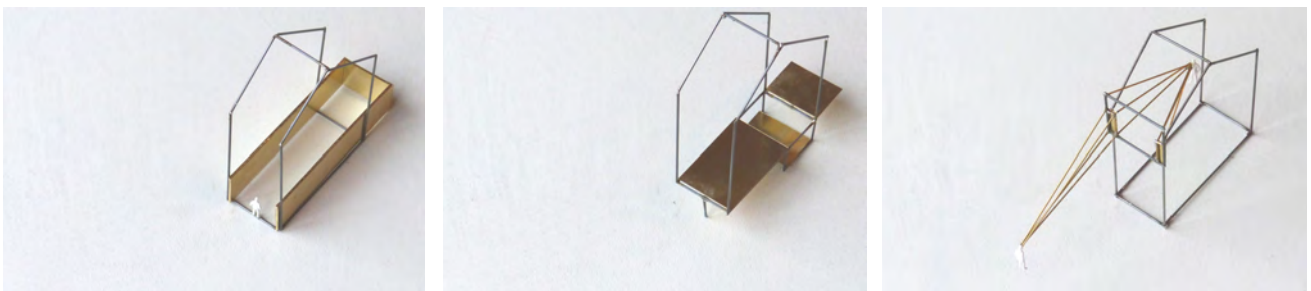

_the Research Studiolo, constructed as a heterogeneous connection of fragments.

In general, I consider one of the main contributions of my research to be that when browsing through the intermingled landscape of practices, artifacts, and discourses that constitute it, when encountering these artifacts in urban reality, one is invoked to become aware of and change one's usual understanding of architectural artifacts. One is invoked to wonder and form a

Figure 3.1: Some of the important propelling artifacts of Architecture's Poetic Instrumentality. Photographs: various authors (see previous sections and chapters).

different understanding of their critical, political, and ethical potential—their probing, provoking, and poetic instrumentality.

It is not obvious to back up the aims and claims of a contribution here by means of providing *direct evidence* in the form of clear-cut particles of knowledge my research adds to an existing body of knowledge. As stated in Chapter 2, rather than confirming to the *masonry metaphor* of knowledge production by means of adding building blocks of the propositional kind, the intermingled landscape I have laid out in this thesis produces a certain *tone*, radiating from a specific set of architectural artifacts, resonating with the aforementioned *ways*. A *tone* I count upon to infect other practices in architecture and other practitioners, including the practitioner that is the one encountering architectural artifacts on site, within situations. A *tone* that foregrounds expressions of architectural intelligence that can be repeated, so to speak, and situated knowledge that can be used in a productive and transformative manner within new situations. To recapture Dyrssen, architectural and artistic research must rethink their judgement of value, and hence of their making contributions, conceiving of them more as an enriching “shaping, constructing and modelling activity” (Dyrssen 2017, p. 177). The rethinking promoted here is part and parcel of the re-conceptualization of artifacts and accompanying approaches, strategies, and attitudes this research set out for.

The *shaping, constructing, and modelling* activity advocated for in the words of Dyrssen advances architectural research as a “compositional approach—so strongly connected to interaction with the material”. It “enhances thinking and interacting that involves bodily engagement, awareness of social dimensions, transversal logics and formative actions.” It composes *descriptions* and *prescriptions, real and what-if? scenarios* (Dyrssen 2017, p. 181). Besides *performances*, it composes *proformances*, deploying what Dana Cuff and Roger Sherman have called a “proformative capacity” of architectural artifacts, able to prefigure alternative directions and as such influence the course of situations (Cuff and Sherman paraphrased in Dyrssen 2017, p. 181). Value in the realm of architectural research, and with it the idea of judging the contribution to knowledge a research makes, here is identified as the “enriching” of situations, of “contexts and perspectives” (Dyrssen 2017, p. 182). The artifacts of my research, in communion with the deployment of the *ways* listed above, *embody* such activity of *modelling*, of *enhancing thinking* close to the material, of *performing* and *proforming* so that situations become enriched. In this way my research has contributed to knowledge. *What* has become modelled and *what* knowledge has been produced I have surfaced in each specific situation and close to each of the specific artifacts populating Chapter 1 and 2. It should be noted that the “compositional approach” here, directly “connected to interaction with the material” in the words of Dyrssen constitutes an alternative view on aesthetics (Dyrssen 2017, p. 182).

Evidence of the aim and claim of a contribution I have also *sensed* in the *enthusiasm of architectural practice* shared by other practitioners on both the experimenting grounds of educational and professional practice. While I can *sense* this being the case,

resulting also in ongoing collaborations that adopt aspects of my research, I cannot easily foreground hard, direct evidence. I have not been setting up interviews or participant observation as a research method, for example. In the introductory chapter on the methodological approach of my research I have suggested reasons for this. However, there is concrete evidence to be found that through the architectural artifacts of my research a contribution of the kind described above has been made. I will specify this claim by advancing in detail some of the reported influences one of the propelling artifacts of my research has had, opening up discussions on a variety of themes, invoking a variety of people with different backgrounds and interests (the stakeholders of this research) to *continue* the shaping, constructing and modelling activity set in motion through that artifact. I will come back to this in detail in the next section, keeping the narrative more general for the time being.

Aligning with the above, in the next section I will also relate to the aforementioned question *how, where, and to whom* my research contributes. Generally, the *how* as said relates to the *ways* and artifacts listed above. The *where* I situate both in the intermingled landscape of practices, artifacts and discourses that constitute this thesis, conveying a certain *tone*, and in the concrete sites / situations within the urban environment where the artifacts have been inscribed, encountered and (still) act and affect. The *to whom* is tied to the other questions, and will be addressed when detailing some of the influences one of the artifacts has had, as announced above. There are two main categories of stakeholders envisaged: that of professional practitioners making or conceiving of architecture and that of the urban practitioners encountering architecture.

Aside from its relevance to the discipline and practice of architecture, my research thus clearly aims to have an impact *outside* of these. The deployment of architectural intelligence substantiates not only in the form of solid matter but especially in forms of *mattering*. Local situated knowledge herein is seen as always relating to larger and wider scales and frames of knowledge production, and to larger sets of concern. As a consequence of this positioning, I have connected throughout my research to such larger sets of concern, which are essentially shared, coming from *outside* to the realm of architecture in the form of (wake-up) calls.

In the above, I have moved close once more to the nature of pragmatist approaches to architecture (and architectural research), which operate through probing and speculating making and modelling activities within situations, in order to engage with, grasp differently, and subsequently change reality—*for the better*. Architectural intelligence is not just deployed and situated knowledge is not just developed to merely describe or study existing reality and derive particles of objective knowledge from it. Instead, they are seen as tools for action and project.

Based on the above reasoning, I want to center the conclusion of my research in two main areas of contributing. One revolves around the idea of *substantiations* as contributions. The other revolves around the idea of a recurrent presence in my research of *productive tensions between seemingly opposed terms* (approaches, strategies, and attitudes).

Thinking about how this research project contributes to an altered conceptualization of architectural artifacts and their deployment, to my understanding ways of *giving substance* have been crucial: a giving substance to particular attitudes, approaches, and strategies, as well as a giving substance to particular architectural artifacts, in communion with one another. Both strains have helped to edify the reconceptualization of architectural artifacts set out for, finding expression as the intermingled landscape of practices, artifacts and discourses this thesis has become.

I want to further elaborate now on the idea of *contributing through substantiating*. It should be noted that this notion can be considered as a specific concept (and contribution itself) proposed in this thesis, which connects more generally to the theme of communication and transfer of knowledge in architecture. *Contributing through substantiating* is considered here a kind of knowledge transfer through substantiating, and this in a variety of ways. In that sense, *contributing through substantiating* is one way of articulating the often used but rather elusive notion of *tacit knowledge* in/of architecture, and how this can be communicated. I associate the above closely with the fifth aspect of Cross's conceptualization of "designerly ways of knowing," i.e. the aspect and capacity of both "reading" and "writing" in "object-languages" (Cross 2006, p. 29), two dynamics that characterize my research.

I have, in a variety of collaborations and on different experimenting grounds, invested intensively in the co-designing and co-constructing of some speculative architectural artifacts. Being speculative, these are not merely artifacts of an architectural practice (as a realm apart from research); instead, their crafting, their preparing and arranging has always been directly connected to the development of my research, which has left a particular mark on them. Put differently, the projects would have been different if they had not been connected to and developed within the context of my research. This goes for the complicating machines and interiors (Chapter 1) as well as for some of the walled artifacts (Chapter 2). All of the projects summed up above have developed within the timespan of my research, starting from the very outset of the research. This *timing* constitutes a condition for them to be considered not as mere exemplifications or translations of some a-priori and found discourses; conversely, they are themselves the driving and developing dynamic of exploration. Thus, these artifacts and the practices that spawn them can be considered true pragmatist endeavors. They operate *within* situations in speculative ways, aiming to produce situated transformations and situated insights (about architecture, or about reality and the situations that make it up). Similarly, this very research can itself be considered as a situation *within* which the artifacts and practices have been developed.

Having stated that the artifacts would have been different if they had not been developed within a research context, the reverse perspective is also valid. There would not have been this kind of research without that kind of projects. I like to think of this in terms of a mutual infection. This is an important aspect of my

research, and it also explains its main methodological approach—that of *research-through-practice*. Moreover, it is an important aspect because it establishes another condition to enable the artifacts and practices to be considered as contributions themselves. Each in its own way contributes to and expands the repertoire of architectural intelligence and situated knowledge related to the inhabitation(s) of the urban. Each in its own way embodies and substantiates a critical, political, and ethical working through their deployment as probing, provoking, and poetic instruments. Out here (in this dissertation) and out there (in urban reality) they continue to touch multiple audiences. They are matter for encountering in various ways.

Thus, *contributing through substantiating* by developing and/or constructing architectural artifacts and practices is effective and affective in different ways and addresses various audiences. In local encounters within real situations, the urban wanderer is inspired to wonder and make sense of a situation as a result of being bodily confronted with and affected by another sense of architectural artifact. The door is thereby opened to the production of situated knowledge. It should be noted that even a partial failure of an artifact or practice can be ultimately enlightening and give way to further experimentation, as was made clear when describing the Walled House project.

Within the space of this thesis, the artifacts and practices developed are the protagonist forces driving the research. They propel and give substance to the meandering connections with broader contexts that extend beyond the field of architecture. I wish to repeat that, as has been shown, these artifacts give substance to a variety of urgent calls raised in fields *separate* from architecture—fields that in similar ways are engaged with conceiving of their possible relevance to the construction of reality, creating in parallel (re-)conceptualizations of their own functioning. Concepts such as *agonism* and *dissensus*, approaches such as *conflict-driven modes of creative practice*, and ideas on *agency* and *vibrancy*—all of these have advanced first and foremost *through* the development and deployment of the artifacts and practices of my research, having no concise name or specific connection at that time. These concepts, approaches, and ideas have only gained a *proper* identification beyond the vagueness of initial hunches, desires, and intuitions in the aftermath of having started to design and develop them. Only then did the connections with other realms begin to take shape.

Often it is difficult to separate cause from effect, to define what comes first and what follows. Some of the shared challenges and concerns were identified in an early stage as open invitations. I think here, for example, of the invitation found in political philosophy to set up creative practices more politically in order to re-figure reality (e.g. the invitation to make public space political again, traceable in the work of Chantal Mouffe and Jacques Rancière). Such fields and the voices calling from them are able to clearly and systematically identify things going on and going wrong, things that call for acts of such re-figuration. In their own words, they lack the particular capacity for *substantiating* their concerns and the propositions they formulate in order to address these concerns. They lack the capacity for substantiating that

would enable them to impact reality more directly (outside of discourse). Put more architecturally, they lack though the capacity for spatializing problems, from which processes of negotiation—of new questions and propositions—may sprout, processes that would render public space a fundamentally political space. Architecture and other creative practices, on the other hand, are more naturally equipped to give substance to such problems and discourses, enabling them to be encountered more directly. They do not operate from distanced perspectives, as theory is often charged with, but radically operate *within* situations. Creative practices rely first on affect rather than on understanding. They do not superimpose concepts, crystallized thought, closed conceptions of reality, worldviews, attitudes, or logics for approaching reality onto situations. Instead, they set the stage for ongoing negotiation and construction. They run along acts of encountering, using, occupying, appropriating and abusing as preludes to processes of negotiating and making sense. They can be critical and at the same time suggestive and propositional. Architectural artifacts can be deployed as discursive artifacts—as “para-functional” objects (Dunne 1999). They can be diagnostic as well as projective—a projecting through project. They have a capacity for rendering visible, audible, tangible, and thus sensible. They bring into substance things that were previously unarticulated, underexposed, or latent but already fully real, and in that sense they are critical. They bring urgent matters of concern to sensation through matters of a more direct artifactuality. The above is not an estimation I alone hold. Quite the contrary, it is an estimation many *outside* fields and sources hold as well. These fields indeed have defined aesthetic practices such as architecture as the ideal locus for giving substance and projection to some shared and urgent matters of concern, exactly because of such qualities and potential.

Paradoxically, in a simultaneous movement with the identification of a particular potential residing in aesthetic practices, these outside fields and voices identify them as ineffective at realizing and wielding this quality and potential. I have referred to voices stating that architecture’s capacity for acting practically as well as critically, politically, and ethically in reality are currently “atrophied” (Kwinter 2002, p. 5). Architecture is not often advanced as an “agonistic” practice (see Mouffe 2010), though it can and should. Often consensus and not “dissensus” defines aesthetic practices’ processes and aims, which as a consequence cannot lead to a “re-partitioning of the sensible” (Rancière 2010). There is the concern for a poor interpretation of what it means for an architectural practice to be “political” (Van Toorn 2006) and “projective” (Janssens 2012), a loss of projective quality that impedes the ability to think situations anew by constructing alternatives. This list is indicative but not comprehensive; within the research, other examples have been explored. The paradox here has led these outside fields and voices to call upon aesthetic practices such as architecture to re-assume their relevant and much-needed critical, political, and ethical role in the questioning and constructing of reality.

In my research I have interpreted these calls as an explicit invitation to engage in (transdisciplinary) adventures centered on

shared matters of concern, finding expression in a set of artifacts and practices (e.g. making the construction of reality political again by designing and setting up the material stages for this). Moreover, I use the term *transdisciplinary* here because these adventures have resulted in artifacts that would have been different if not developed within a research context and thereby connecting with these outside fields and voices.

Besides contributing to some shared matters of concern and answering some urgent calls stemming (also) from the world outside architecture, the artifacts and practices of my research also contribute to what I have referred to as *research-through-practice*. Within the timespan of undertaking my research, I have encountered many sometimes quite oppositional interpretations of this current in research. By designing and setting up artifacts and practices within a research context, I add to that existing and expanding register. The addition here helps reinforce the conceptualization of research-through-practice as not only introspection (introspection into the discipline and practice of architecture); instead, I have oriented research-through-practice (also) fundamentally toward what is outside of architecture: to shared matters of concern. This, I argue, must be the result of thinking about architecture critically, politically, and ethically. Opting for this research approach, then, brings to the fore not (only) architecture but also what architecture is itself able to bring to the fore.

By having developed and deployed the artifacts and practices of my research within real urban situations, at date of publishing this thesis they are still out there radiating their probing, provoking, and poetic instrumentality (even if for some this means that what they radiate is their partial failure). They still radiate their potential for provoking encounters, uses, occupations, appropriations, and abuses. Thus, they still affect the urban wanderers' encountering, making them wonder. They still ripple the surface of the urban environment, occupying some of its porosities. While the Walled House now lacks an important intended agency, for example, it still acts as a refreshing model for inhabiting the urban environment, as noted by the architecture critic Van Synghel (Van Synghel 2017). And these artifacts also have an effect on those browsing through this dissertation. Each of the artifacts brings out aspects that could inform new projects by other practitioners. For example, knowledge of how to substantiate an *architectural time of suspension* is stored *within* projects such as CoMa₀₁ and CoMa₀₂, and this knowledge may provide a point of departure for other practitioners. Focusing once more on the Walled House project, this illuminates a need and desire to deploy architecture more politically, while its failure only strengthens this need. From this other practitioners may decide to craft in their work *corrections* to official programs as I have done in various collaborations—to craft in other articulations of ambiguity that call for appropriation and negotiation by users. This list mentions only two instances of learning that may be picked up, retaken, and further developed by other practitioners. I trust that some of the artifacts and practices may serve those practitioners as mirrors for their own creating practices and conceptualizations of architecture and (its impact on) urban reality. It should be noted that when

considering what the future practices of my research could be, I challenge not only other practitioners but also myself to work from these artifacts and that landscape in which they are embedded.

In the reasoning above, I have spoken of a value for future practices and practitioners, whether these are students, architects, researchers in the field of architecture or other artistic realms, or those practicing the inhabitation of the city on a daily basis. As announced in the opening part of this conclusion, I will narrow down on such value taking at the center the influences the Walled House has had as one of the main propelling artifacts of my research. In the aftermath of its being designed and constructed, a variety of discussions and debates have connected to it. The artifacts have served hence as *conversation pieces*, drawing in a wider palette of interests and concerns, and with it a wider set of audiences and stakeholders that exceeds the profession of architecture. These reported influences that emerged without initiative from our side, I consider as evidence of a contribution having been made. While I select the Walled House because here the influences are best documented, similar influences can be advanced for the other artifacts. I will structure the influences of the Walled House according to the experimenting grounds that structure this thesis.

Within an educational context, the Walled house has been adopted as a case in diverse programs, both nationally and internationally. I advance some of them, giving an indication of the various discussions the project helped substantiate. As I have shown, in my own educational practice the project has been used to discuss the notion of architectural / spatial agency, for example by giving substance to the idea of *agonistic staging*. More specifically, I centered a lecture on the project as a contribution to the program *Double Readings*, organized by Freddie Floré in the Master of Interior Architecture program at KU Leuven Faculty of Architecture, Campus Sint-Lucas. Around eighty master students attended a double lecture by Ana Kreč and myself, entering a debate on the specific theme of small-scale strategic interventions in urban contexts involving the interior as a catalyst, and more generally on research-by-design approaches (2016). In her master dissertation at the Faculty of Engineering and Architecture at Ghent University, Lisa Dierick involved the materiality of the Walled House—its all-encompassing brickwork scale—as a case for exploring a possible renewal of the material culture of masonry in Belgium. A conversation between the student and us architects served as one point of entry herein (2017). Françoise Hoogaerts, a student of the Master of Interior Architecture program at Antwerp University, selected the project for exploring specific contemporary typologies of habitation within urban contexts (2017). She had encountered our project in SOG's permanent exhibition overviewing contemporary urban projects in Ghent, set up mainly to address a broad audience of (future) citizens. In an international context, students Sara Casey, Mikkel Rasmussen, Marcus Innvær, and Oliver Lehrmann of the Royal Danish Academy of Fine Arts (KADK), School of Architecture, visited our office and analyzed the Walled House in the framework of the Settlement, Ecology and Tectonics program (SET). The house was

specifically selected for its resonance with the research theme of *resilience*. In the publication that followed the analysis, the students defined resilience as “the capacity of a system to absorb disturbances and to reorganize itself while [...] undergoing changes” (SET publication *Field Studies in Belgium*, 2017). The description of resilience here resonates with the narrative of the Walled House developed in Chapter 2. The analysis entered a wider knowledge bank, accessible to all students of the SET program. The research seminar *Individual and Collective Habitations* (2018) led by Henk De Smet at the Master of Architectural Engineering Sciences program at KU Leuven included the project as a relevant case of contemporary urban housing, showing specific interest in how architecture frames contemporary practices and usages of urban inhabitants. The project figured as a case in the master dissertation (by-design) of Mathilde Jacobs (2018), embedding it in the wider context of the *Graduating through Portfolio* program led by Arnaud Hendrickx en Nel Janssens in the Master of Architecture program at KU Leuven Faculty of Architecture, Campus Sint-Lucas. Here, the project was studied on site in Ghent and *copied* on a site in Brussels, adding to it a level of complexity by re-conceptualizing it as a collective housing project. I deliberately speak of a copying here, not only because of the clear similarities in the design’s articulation, but because this proves the aforementioned repeatability or continuation of *ways* of deploying architectural intelligence and situated knowledge.

The Walled House has recently been adopted in the program *Interiors: This is Belgium*, led by Klaas Vanslebrouck, connecting groups of international students studying temporarily at the KU Leuven Faculty of Architecture to a series of selected Belgian interiors. In the program, these international students can meet and discuss (interior) architecture with both designer and inhabitant while experiencing the architectural artifact on site (2019). In a first visit, the students showed much enthusiasm in relation to the projects lay-out and materialization, allowing me to assume the house’s influence now is travelling abroad. In the near future (2020), first year students of Applied Architecture at Howest Bruges Amber Lievens, Haici Van Belle, and Julie Loosvelt will analyze the project as part of the *Synthesis of Architecture* course. Third year students of the faculty of Engineering and Architecture at Ghent University Janne Cauwels, Kevin Vanlerberghe, and Simon Vanlaere will also analyze the project, be it from the perspective of building physics, focusing on what they call interesting construction nodes. Accompanying their correspondence was a photograph they took themselves of such a construction node, which I add here.

The above adoptions are situated in educational research contexts, stimulating debate on research-by-design, research on materiality, research on architectural typologies, research on socio-spatial relations, and so on. As part of my research the Walled House has also figured in more traditional and international research venues. It has been presented and published in the frame of research conferences and seminars, for example at the occasion of the 2017 Architectural Research European Network Association conference *Impact by Design*.

Figure 3.2: One of the construction nodes of the Walled House that triggered the curiosity of students Janne Cauwels, Kevin Vanlerberghe, and Simon Vanlaere. Photograph: Anne Cauwels, Kevin Vanlerberghe, and Simon Vanlaere.

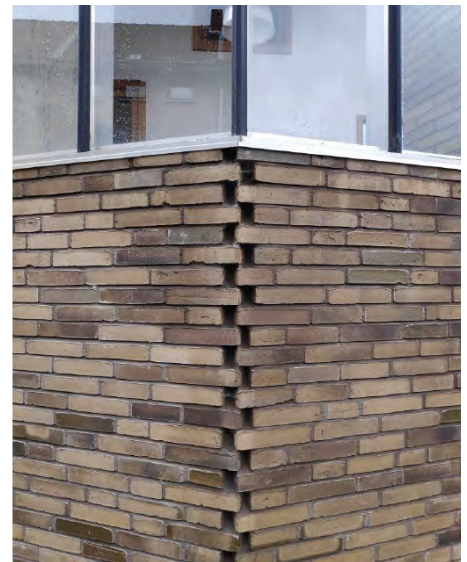

Other encounters with and publications of the Walled House have targeted professional and disciplinary audiences, as well as laypeople. As touched upon in Chapter 2, it was published in the 2016 *Flanders Architectural Review N°12: Tailored Architecture*, a publication by the Flanders Architecture Institute (VAi). Also, it was part of the 2015 Festival of Architecture, appropriately titled *Maken en Mee-maken*, which translates both as *Making and Making Together* and *Making and Experiencing*. The Walled house was opened to the public on this occasion, and both inhabitants and designers engaged in conversations with the public. Giving a taste of the audience VAI targets by its publications and events, it defines its role as being the “main center for information about architecture” nationally (in Flanders and Brussels), serving as “a platform for everyone who wants to make, share and experience architecture” (VAi mission statement). For the book *Tailored Architecture*, projects were selected specifically on the basis of their resonance with themes such as the “cultural and social purpose” of architecture, the production of “communal space,” and “the status of the public domain” (*Flanders Architectural Review N°12’s* publication text).

In popular press, there has been the aforementioned 2016 article in *De Standaard*, in which the Walled House is advanced by architecture critic Van Synghel as a (re-modelling and shaping) model able to seduce people to go and live in cities. The article as said in Chapter 2 is written against the background of the debate on the present-day challenge of the Belgian *betonstop*, a call to halt further covering of the soil and landscape with concrete and end the all-devouring consumption of the scarce open space remaining in the Belgian landscape. Other articles covering different interests have been written on the project.

The project has been adopted in a variety of publications and venues where the profession of architecture meets a large audience of laypeople, promoting certain materialities and typologies. Examples of this are the adoption in the 2016 publication *Building with Bricks*, in the 2018 publication *Extraordinary Belgian Building*, and the adoption as the laureate of the BIS Architecture Competition in the popular 2016 BIS fair. As advanced in Chapter 2, the Walled House was also selected as the 2010 laureate of the SOG competition Urban Lots (*Stedelijke Kavels*), on the basis of parameters sketched out in Chapter 2. The project has also been discussed on urban fora driven by private citizens such as *gentcement.be*. The most recent connection of the Walled House is that it has been selected for the 2020 Biennale Architettura in Venice. It will be presented at that occasion as part of a fictional but typical Flemish urban landscape, built on a 1:15 scale, exploring the friction between architecture and the city, emphasizing the typological particularities, scale differences, radical juxtapositions, and mixed functions the latter consists of.

I have specified in detail here some of the adoptions of the Walled House in educational, professional and other public venues. I have done this for it shows how one of the protagonist artifacts of my research has an ongoing agency within these venues, influencing the debate close to (and research on) multiple interests, affecting a varied audience. I have done this because in some of these influences, a repeatability of *ways* of deploying and

articulating architectural intelligence and situated knowledge can be perceived. The list above I consider to evidence the artifact's ongoing agency, beyond own beliefs, hunches and assumptions.

Asides the reported influences listed above, the Walled house and the other artifacts of my research still act and affect in their urban surroundings, acts and affects I cannot capture. The construction of a project such as the Research Studiolo is only yet commencing its path of provoking and substantiating acts of *urban poesis*.

In the above I have touched upon a relationship that exists between the contributions made and the variety of audiences targeted in my research project. I have addressed urban wanderers wondering, present and future inhabitants of the city, architectural practitioners and researchers, and students of (interior) architecture. This has also influenced the structure my research project has taken. Two main experimenting grounds have been substantiated in the course of my research, finding expression in two separate chapters (the experimenting ground evolving around craft I adopt here in the second experimenting ground / second chapter). Each of them experimented in their own way with a probing, provoking, and poetic instrumentality—with the critical, political, and ethical capacity of architecture.

Close to the tension between both experimenting grounds, I situate the most personal contribution my research makes to wider contexts. I have one given moment shifted the terrain of experimentation specifically toward what some conceive as the center of architectural practice: the working terrain of an architectural office producing urban dwellings. This could be seen as a paradoxical shift, because it encompasses a substantial multiplication of all kinds of impeding constraints rather than a multiplication of all kinds of liberties. However, I argue that a territory has more clearly surfaced through that movement that currently seems rather to escape the scope of practices and currents conceiving of architecture's agency and its critical, political, and ethical capacities. I say it has surfaced more clearly because that territory surely already exists. It is not often made the center of attention, though. In the course of my research project, I have traced aspects of it in the work of architects such as Rossi and Cuyvers. I have found it suggested in concepts such as “para-functionality” found in Dunne, which stands, as it were, on the shoulders of the usual functionality. It is suggested in registers such as those of “spatial agency” (Awan, Schneider & Till, www.spatialagency.net) and in publications on critical design. However, in such registers, they disappear quite easily from view, surrounded as they are by much *louder* or more *present* variants. Oversimplifying a bit, and without wanting to decry their importance to the construction of reality, one can more easily find substantiations of intense and openly activist and participatory practices, of the colorful pallet of so-called currents such as tactical urbanism, of expressive ecological, sustainability- and community-driven practices, and of practices experimenting with deviant kinds of materially composing and articulating. Speaking through artifacts rather than currents, one can more easily find plastic human-fit bags parasitizing on exhaust air vents from heated buildings. One can find more easily temporarily occupied



Figure 3.3: Michael Rakowitz's project Parasite, putting the homeless on display while stating its message with clarity. Photograph retrieved from <https://www.moma.org/calendar/events/1872>.

in-between lots in the urban environment that now serve as community gardens where people meet and engage. These are incredibly important for constructing “other ways of doing architecture,” “re-partitioning the sensible,” and re-figuring reality. I subscribe to their necessity and brilliance. They indeed re-partition and re-figure in affective ways the sensible, also expanding the registers held of the potential of architecture. However, I am personally intrigued by a *modest* preparing of architectural instruments. Similarly, I am intrigued by the tension between human-centered kinds of spatial agency and more object-oriented kinds of artifactual agency, which think highly of the alluring presence of material assemblages. I am more fascinated by the tension between architecture operating as a background (experienced in a state of distraction) and a subtle but nevertheless challenging foregrounding from it. I am also intrigued in relation to this by architecture's *usual* material substance and articulation. It follows that the territory that has more clearly surfaced, as hinted at above, is developing and deploying specific ways of doing architecture *otherwise*.

Recapturing the scheme I have drawn of a gradient that ranges from invitation to provocation to a shock to thought, I have always been intrigued by the more subtle deviations between the extremes of shock and invitation. The surfacing more clearly above, then, refers more to a *silent* working through the artifact—to a *modest* kind of preparing, arranging, and setting artifacts. In the particular architectural practice I am part of, I favor the idea of *corrections* over more exuberant efforts. This does not imply that the reach and impact of the approach I follow would be more limited. I think back to the homeless man who is on a continuous journey of *making home* in the urban environment, a man I introduced in the introduction to my research. I try to imagine and feel his occupation of an inflated plastic bag through which warmth flows. That act is literally too *loud*, in my opinion. It is too loud in the literal sense of the crackling plastic materiality surrounding the exhausted body but, more importantly, it is too loud in the sense of making that body present, almost putting it on display. I imagine, in comparison, that body occupying the depth or porosity of a walled construction as it could have been found in the Walled House's enveloping brick cliff and floe as designed. In both I appreciate a generosity and a certain functionality constituting this generosity. In both I appreciate how their para-functional working calls upon the imagination. Architectural artifacts such as these provoke those who encounter them to take a position—to start thinking about and negotiating the socio-spatial setting encountered as well as its wider ramifications. However, in the case of the spaces receding in the Walled House, I appreciate the commonness of its sheltering surround, in which a making and claiming of home remains possible. The exchange of warmth with the body is not the only condition for making and claiming home. As far as I can imagine, in this making a home in the urban environment, the shear physical but also mental movement of receding and retracting is just as substantial—the idea of being embodied in firm surroundings. Beyond this distinction, and this is important, I think highly of the various readings, uses, interpretations,

appropriations, occupations, and abuses such receding articulations and porosities as they were envisioned in the Walled House could have allowed and fostered. While the plastic human-fit bag states its intention with precision, unambiguously, to the one using it as well as to the one witnessing it, the porosity of some brickwork recessions allows for more ambiguous readings. An accordance can be seen here with the inherent multiplicity of the urban environment, where complexity and division are common and different worlds exist in one. In that way, architecture is about “making space” *and* about “leaving space for interpretation,” as Till has suggested (Till 2009, p. 108), just as much as it is about building spaces for thought in the midst of things, as Rajchman has suggested (Rajchman 1998, p. 2).

In relation to the above, one may think back to Calle’s additions to a peculiar urban spot, cultivating that spot by adding alien props to the situation. The creative activity here soon becomes game-like. Recessions in a brick wall radiate their potential through usual and modest articulations of matter, as opposed to a spectacular or plainly odd and alien architectural materiality. They speak through architecture’s usual flesh, so to speak.

Condensing the above, and characterizing more precisely what I have called a most specific and personal contribution, my research project is in no way about seeking *alternative* ways of doing architecture; it is about doing architecture differently, working through the slightest and most subtle deviations and through architecture’s usual materiality. A similar approach to architectural practice is suggested by Cuyvers, who has stated in the A+ publication entitled *[Re]politicize!* that in his quest for a more political architecture he is not looking for an “alternative” architecture (Cuyvers 2016). Such an alternative architecture, in my understanding, would constitute not merely an alternative to but an alternative *against* architecture. As is suggested throughout this thesis, doing architecture differently is a promise and capacity residing *within* architecture itself, though it is seldom articulated.

contributions through giving substance to a landscape of productive tensions

Thinking about how my research project contributes to a shifting sense of architectural artifacts and practice, a recurrent aspect that became apparent during the course of my research is the productive tensions that exist between various seemingly opposed terms. It is precisely this tension between opposed attitudes, strategies, approaches, and concepts that is identified as productive.

From the outset it has taken an interest in and placed at the center the tensions between seemingly opposed attitudes, strategies, approaches, and concepts of architectural artifacts and practices. This becomes immediately clear when considering the title of my research project, which puts in productive tension the notion of instrumentality *and* a dynamic of probing, provoking, and poeticizing. While the former opens up the possibility of seeing the architectural artifact as a productive instrument engaged in a production, the latter retains the promise of that



Figure 3.4: A first and underdeveloped proposal for the walled recessions in the Walled House, ambiguously inviting a variety of occupations and appropriations. Drawing: Johan Liekens.

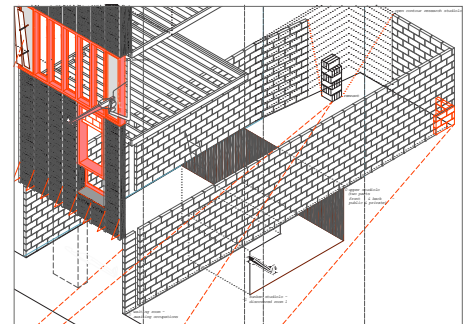

Figure 3.5: The receding brickwork contour of the Research Studiolo, inviting ambiguously and over time a variety of occupations and appropriations. Drawing: Johan Liekens.

production having poetic qualities. With the poetic here I again refer to its interpretation as a making (up) activity that is specific and unique within each situation, within each encounter. At the productive intersection of the two I have situated the construction of the architectural artifacts that populate and propel my research project.

There are numerous other productive tensions for which my research and its artifacts prepare stages and construct contours. In relation to the above discussion, I think of the stages offered to the tension between functionality *and* poesis. This is manifested most clearly in my adherence to and the tentative substantiations of the intriguing concept of “para-functionality,” a kind of *speaking through* that is firmly based on utility but “attempts to go beyond conventional definitions of functionalism to include the poetic,” to use Dunne’s exact words (Dunne 1999, p. 44). I think also of the manifest presence in the research of problem-solving *and* problem-setting orientations, of affirmative *and* critical ways of designing, of policing *and* political approaches and tendencies in constructing urban reality and how architecture is implicated in this. Exemplifying the latter tension, my research literally has prepared a stage in the Walled House project. As suggested before, that artifact and other artifacts were not designed expressly to exemplify prior ideas, such as the idea of a tension between policing and political tendencies in the construction of the urban. Nor does it strictly function as a case from which more abstract principles can be deduced (as objective knowledge, as theory). The idea of tension and struggle between policing and political approaches and tendencies in the construction of reality in the case of the Walled House emerged within the timespan of its being designed, developed, and deployed. It is palpable first and foremost there, on the streets, in everyday reality. And it is palpable in this thesis, where it comes to the fore through one of its failures.

What I want to highlight here is that in my research there is always and essentially first and foremost the idea of tension and giving substance to this tension. Even if I have clearly advocated for political attitudes, strategies, and approaches, for example, these do not exist without their counterparts with which they are always engaged in a tension, a friction, a conflict, a struggle. As has been suggested by Rancière, many times the political builds its stages within policy and vice versa. The one needs the other for its own articulation. Or rather, the one needs to be in perpetual tension with the other in order for a re-partitioning of the sensible to even be possible. Such a re-partitioning is itself at most a temporal stability. Favoring and productively using the tension between terms, rather than the terms as such, is what is important in my research. If there were no policy, there would be no aspiration for a commons. If there were no politics, nothing new would emerge and catch the body sensing and making sense. Rephrasing, if there were no tension, there would be no re-partitioning of but only a partitioned sensible solidified as such. The same goes for the tension between conception and reception, between design and occupation, between practice and discourse, between the practical and the imaginative, between

consensus and dissensus, and between affirmation and critique. Recapturing Mouffe on this, she has pleaded for an interpretation of “agonism” as a (counter-)hegemonic struggle, a struggle that is always a struggle for dominance as well as *against* dominance (Mouffe 2013). The kind of tension advocated for here is not to be thought of as destructive, however; it is first and foremost one that advances productive processes of negotiation, bringing into flux the seemingly stratified, the unquestioned, the paralyzing evidentness of what is (proper).

The reason for giving so much emphasis to one pole of terms (the critical, the political, the ethical, the projective, the imaginative, the strange, etc.) is that these are not often accounted for—in conceiving (of) architecture, in conceiving (of) reality. Often there is no awareness of them in processes of designing, developing, and deploying architectural artifacts and practices. I have conceived of them, conversely, as needing to be added to the dominant registers already held and worked with, provoking by this addition a tension that sets in motion a re-partitioning of those very registers. To an addition in that sense, the artifacts and practices of my research constitute a contribution.

In concluding, I want to bring to attention two more productive tensions I have given substance to. First, there is the tension deliberately left unresolved between human-centered notions of architectural agency and more object-oriented and artifactual versions. I speak of a leaving unresolved, but it would be better to state that there will never be a resolution and always a tension. This is a good and productive thing. Each of these perspectives is of crucial importance to architecture if it wants to revive its atrophied capacities of acting in and on the world. Hence, it is once more about giving substance to a productive tension between poles, which can raise an awareness of some of architecture’s potential.

A last but important productive tension with which I wish to conclude is the latent tension between the cool territories of aesthetics and pragmatism and the hot territories of the critical, political, and ethical. My research project has intended to give substance to their reconciliation. It has intended to give substance to their appearing and functioning as melted. Or rather, reconciliation here has to be interpreted in terms of the two drawing near one another, a tension that causes sparks of energy to pass over from one side to the other and back again. Ethics unfold through aesthetics and, as suggested above, they are dependent on aesthetics to become sensible and gain tangible expression—on the streets, in the reality of everyday situations and practices. Ethics unfold through pragmatist productions and endeavors or, using the exact stipulation of Lefebvre, “the introduction of pragmatism in the realm of architecture has [...] been taking place paired with promises for an ethical account of architectural practice and production” (Lefebvre 2014, abstract).

some reflections on future research

In the above I have emphasized the contributions my research makes through substantiating, and thereby expanding

the registers held of reality. This includes the registers held of architecture's conceptualization itself and of its critical, political, and ethical capacities—of its probing, provoking and poetic instrumentality. Given my specific position as a researcher, a teacher, and a practicing architect, given my particular interest and methodological approach to move in on this interest, an important part of future research will be working through next sets of architectural artifacts. I think of the continuation and constant course changes of the project Research Studiolo, of some urban projects on STUDIOLOarchitectuur's shelves, but also of some new and challenging projects within the collaborative and educational context of the Academic Design Office entitled The Wicked Home (<http://www.blog-archkuleuven.be/wicked-home>). Here the emphasis will be on the exploration of the wicked matter, wicked ways, and wicked problems of architecture and on the idea of more-than-human agencies within architecture. These sets can further refine the re-conceptualization of architecture already set in within this thesis, substantiating in parallel a set of attitudes, strategies, and approaches that other architects can work with as well. Of course, I envisage future research to be embedded in collaborations with others.

Second, the intermingled landscape that my research project brings to the fore and that I have called immersive, complex, and heterogeneous could, in my understanding, benefit from a further process of *extraction after writing*, in which more attitudes, strategies and approaches are *named* as concepts. Such concepts, together with those already extracted, could contribute to existing theoretical frameworks. Still situated and specific, such concepts would be transferrable and repeatable in a more general sense. Further delineation and terming would also make my research accessible in a different way. However, as said, I have deliberately opted to invite the reader in by introducing him or her in an immersive and intermingled landscape with a peculiar *tone*. Herein many connections between artifacts and ideas of various kinds are suggested as well as elaborated. Herein knowing stemming from various disciplines connects. Herein attitudes and strategies for deploying architecture become tangible more directly. Moreover, the intermingled landscape allows readers to make their own connections.

In this immersive landscape, with that particular *tone*, the specific architectural artifacts have themselves become adopted and intermingled, hence enabling them to transcend their own specificity as the unique artifacts of (a) practice(s). In that sense they help compose the complex construct of my research assembled as a landscape that lends itself to such processes of extracting transferable concepts—transferable attitudes, strategies, and approaches.

As suggested, such an extraction would make it possible to more easily wield the re-conceptualization of architecture and its artifacts composed throughout this thesis. It would make it easier to deploy them in contexts such as architectural education (the first experimenting ground) and architectural practice (the second experimenting ground). Such a vocabulary, which conveys that *tone* more concisely, could potentially provide architecture with another powerful probing, provoking, and poetic instrument.

★_13.

REFERENCES

- Aureli, P. V., ed., 2014. *The City as a Project*, Berlin: Ruby Press.
- Auster, P., 1990. *The Music of Chance*, New York: Penguin Books.
- Auster, P., 2004. *Leviathan*, London: Faber & Faber.
- Awan, N., Schneider, T., and Till, J., 2001. *Spatial Agency: Other Ways of Doing Architecture*, Abingdon, Oxon: Routledge.
- Baird, G., 2007. Criticality and its Discontents. In W. S. Saunders, ed. *The new Architectural Pragmatism*. Minnesota: University of Minnesota Press, pp. 136-149. Boie, G., 2008.
- Benjamin, W., and Lacin, A., 1978. Napels. In P. Demetz, ed. *Reflections: Essays, Aphorisms, Autobiographical Writings*. New York and London: Harcourt Brace Jovanovich Inc., pp. 163-173.
- Bennet, J., 2010. *Vibrant Matter: A Political Ecology of Things*, Durham and London: Duke University Press.
- Boie, G., 2008. Wim Cuyvers: Interventie op Begraafplaats. In G. Boie et al., eds. *Jaarboek Architectuur Vlaanderen Editie 2008*. Antwerpen: Vlaams Architectuurinstituut, pp. 122-125.
- Burroughs, B., Ring, B., and Beal, H.T., 2016. *Architectural Flirtations: A Love Storey*, Stockholm: Arkitektur- och Design Centrum.
- Borgdorff, H., 2010. The Production of Knowledge in Artistic Research. In M. Biggs, and H. Karlsson, eds. *The Routledge Companion To Research in the Arts*. Abingdon, Oxon: Routledge, pp. 44-63.
- Bourriaud, N., 2002. *Relational Aesthetics*, Dijon: Les Presses du Réel.
- Bowen, S., 2009. *A Critical Artefact Methodology; Using Provocative Conceptual Designs to Foster Human-centred Innovation*, Sheffield: Sheffield Hallam University.
- Calle, S., 2007. *Double Game*, London: Violette Editions.
- Chang, H., 2008. *Autoethnography as Method*, Walnut Creek, CA: Left Coast Press.
- Connelly, F. M., and Clandinin, D. J., 1990. Stories of Experience and Narrative Inquiry. In *Educational Researcher*, 19(5), pp. 2-14.
- Corcoran, S., 2010. Editor's Introduction. In J. Rancière. *Dissensus: On Politics and Aesthetics*. London: Continuum International Publishing Group.
- Cross, N., 1999. Design Research: A Disciplined Conversation. In *Design Issues*, 15 (2), pp. 5-10.
- Cross, N., 2006. *Designerly Ways of Knowing*, London: Springer-Verlag.
- Crotty, M., 2003. *The Foundations of Social Research*, London: Sage Publications Ltd.
- Crysler, C.G. et al., 2012. Introduction - 1: Architectural Theory in an Expanded Field. In *The SAGE Handbook of Architectural Theory*. London: Sage Publications, pp. 1-21.

- Cuff, D., and Sherman, R., 2011. *Fast-forward Urbanism - Rethinking Architecture's Engagement with the City*, New York: Princeton Architectural Press.
- Cuyvers, W., 1995. *Tentoonstellingscatalogus Wim Cuyvers*, Antwerpen: De Singel.
- Cuyvers, W., 2005. *Tekst over Tekst*, Den Haag: Stroom.
- Cuyvers, W., 2016. Politiek van Ik - Architectuur van Ik. In P. T'Jonck, and L. de Visscher, eds. *A+ [Re]Politicize!*. Brussel: ICASD VZW Informatiecentrum voor Architectuur, Stedenbouw en Design, pp. 57-60.
- Davidts, W., 2006. Home improvement - Over het (Totes) Haus Ur van Gregor Schneider. In *De Witte Raaf*, Issue 121, pp. 10-11.
- De Cock, J., 2004. *Denkmal I isbn 9076979162*, Brussel: Denkmal 15 Nv.
- Deleuze, G., 1994. *Difference and Repetition*, London: The Athlone Press.
- Deleuze, G., and Guattari, F., 2004. *A Thousand Plateaus*, London and New York: Continuum.
- Dewey, J., 2011. *La Formation des Valeurs*, Paris: Les Empêcheurs de Penser en Rond.
- Dovey, K., 2007. I Mean to be Critical, But In J. Rendell et al., eds. *Critical Architecture*. London: Routledge, pp. 252-260.
- Downton, P., 2003. *Design Research*, Melbourne: RMIT University Press.
- Dunin-Woyseth, H., and Nilsson, F., 2006. Thinking, Doing, Writing, Researching: The Brussels Experiments in Forms and Processes of Knowledge. In N. Janssens et al., eds. *Reflections*, Issue 3. Brussels and Ghent: Sint-Lucas School of Architecture, pp. 168-172.
- Dunin-Woyseth, H., and Nilsson, F., 2009. Visual Thinking as Bridge Building: Testing a Pedagogical Concept, Drawing Some New Insights. In S. Martens et al., eds. *Reflections*, Issue 9. Brussels and Ghent: Sint-Lucas School of Architecture, pp. 43-50.
- Dunin-Woyseth, H., and Nilsson, F., 2011. Building a Culture of Doctoral Scholarship in Architecture and Design: A Belgian-Scandinavian Case. In *Nordic Journal for Architectural Research*, 23(1). The Nordic Association for Architectural Research, pp. 41-56.
- Dunin-Woyseth, H., and Nilsson, F., 2012. On the Emergence of Research by Design and Practice-Based Research Approaches in Architectural and Urban Design. In M. Hensel, eds. *Design Innovation for the Built Environment: Research by Design and the Renovation of Practice*. London: Routledge, pp. 37-52.
- Dunne, A., 1999. *Hertzian Tales: Electronic Products, Aesthetic Experience and Critical Design*, RCA CRD Research Publications: London.
- Dyrssen, C., 2011. Navigating in Heterogeneity: Architectural Thinking and Art-Based Research. In M. Biggs, and H. Karlsson, eds. *The Routledge Companion to Research in the Arts*.

- Abingdon, Oxon: Routledge, pp. 223–239.
- Dyrssen, C., 2017. Precision: The Compositional Accuracy of Artistic Judgement. In F. Nilsson, H. Dunin-Woyseth, and N. Janssens, eds. *Perspectives on Research Assessment in Architecture, Music and the Arts: Discussing Doctorateness*. Abingdon, Oxon: Routledge, pp. 175-189.
- Eddington, A. S., 1929. *The Nature of the Physical World*, New York: MacMillan.
- Fallman, D., 2008. The Interaction Design Research Triangle of Design Practice, Design Studies, and Design Exploration. In *Design Issues*, 24(3). Massachusetts Institute of Technology, pp. 4-10.
- Findeli, A., 2010. Searching for Design Research Questions: Some Conceptual Clarifications. In R. Chow, W. Jonas, and J. Gesche, eds. *Questions, Hypotheses & Conjectures: Discussions on Projects by Early Stage and Senior Research Designers*. New York: IUniverse, pp. 286-303.
- Forester, J. F., 1999. *The Deliberative Practitioner: Encouraging Participatory Planning Processes*, Cambridge MA: The MIT Press.
- Forty, A. et al., 2006. *Evaluation of Swedish Architectural Research 1995-2005*, Stockholm: FORMAS.
- Frayling, C. et al., 1997. *Practice-based Doctorates in the Creative and Performing Arts and Design*, Lichfield: UK Council for Graduate Education.
- Geuss, R., 1981. *The Idea of a Critical Theory: Habermas and the Frankfurt School*, Cambridge: Cambridge University Press.
- Gibbons, M. et al., 1994. *The New Production of Knowledge - The Dynamics of Science and Research in Contemporary Societies*, London: Sage Publications.
- Gibson, J. J., 1977. The Theory of Affordances. In R. Shaw, and J. Bransford, eds. *Perceiving, Acting, and Knowing: Toward an Ecological Psychology*. Hillsdale, New Jersey: Lawrence Erlbaum Associates, pp. 67-82.
- Giddens, A., 1986. *The Constitution of Society*, Berkeley, California: University of California Press.
- Giddens, A., 1987. *Social Theory and Modern Sociology*, Palo Alto, California: Stanford University Press.
- Goddard, D., 2001. Allan Wexler: Works. In *New York Art World*. Available from <<http://www.newyorkartworld.com/reviews/wexler.html>> (accessed 6 November 2015).
- Goodman, N., 1978. *Ways of Worldmaking*, Indiana: Hackett Publishing Company.
- Gray, C., 1996. Inquiry Through Practice: Developing Appropriate Research Strategies. Available from <<http://www2.rgu.ac.uk/criad/cgpapers/ngnm.ngnm.htm>> (accessed 20 January 2012).
- Groat, L. N., and Wang, D., 2013. *Architectural Research Methods*, New York: J. Wiley.
- Hache, E., 2011. *Ce à Quoi Nous Tenons: Propositions pour une Ecologie Pragmatique*, Paris: Les Empêcheurs de Penser en Rond.

- Harman, G., 2002. *Tool-being: Heidegger and the Metaphysics of Objects*, Chicago and Illinois: Open Court.
- Harman, G., 2012. The Third Table: 100 Notes, 100 Thoughts. In *DOCUMENTA Series 085*. Ostfildern: Hatje Cantz Verlag.
- Harman, G., 2013a. Strange Objects Contra Parametricism. In *SCLARC Lectures Media Archive*, [Video]. Available from <<https://www.youtube.com/watch?v=P6yWc7ccb7g>> (accessed 17 December 2016).
- Harman, G., 2013b. What Objects Mean to Architecture. In *Architecture Exchange Series #1*, [Video]. Available from <<http://thearchitectureexchange.com/series-1/>> (accessed 14 February 2017).
- Harman, G., 2014. Objects and the Arts. In *ICA Lecture Archive*, [Video]. Available from <<https://archive.ica.art/bulletin/video/graham-harman-objects-and-arts>> (accessed 23 February 2017).
- Haseman, B., 2007. Tightrope Writing: Creative Writing Programs in the RQF Environment. In *TEXT, Journal of Writing and Writing Courses*. Available from <<http://www.textjournal.com.au/april07/haseman.htm>> (accessed 17 April 2018).
- Heynen, H., 2007. A Critical Position for Architecture. In J. Rendell et al., eds. *Critical Architecture*. London: Routledge, pp. 48-56.
- Hill, J., 1998. An Other Architect. In J. Hill, ed. *Occupying Architecture: Between the Architect and the User*. London: Routledge, pp. 135-160.
- Jacobs, J., 1961. *The Life and Death of Great American Cities*, New York: Random House.
- Janssens, N., 2012. *Utopia-Driven Projective Research: A Design Approach to Explore the Theory and Practice of Meta-Urbanism*, Gothenburg: Chalmers University of Technology.
- Janssens, N., and Zeeuw, G. de, 2017. Non-Observational Research: A Possible Future Route for Knowledge Acquisition in Architecture and the Arts. In F. Nilsson, H. Dunin-Woyseth, and N. Janssens, eds. *Perspectives on Research Assessment in Architecture, Music and the Arts: Discussing Doctorateness*. Abingdon, Oxon: Routledge, pp. 147-158.
- Karatani, K., 1995. *Architecture as Metaphor*, Cambridge MA: The MIT Press.
- Keshavarz, M., and Mazé, R., 2013. Design and Dissensus: Framing and Staging Participation in Design Research. In *Design Philosophy Papers*, 11(1), pp. 7-29.
- Khosravi, H., 2014. The political Theology of the Islamic City. In P. V. Aureli, ed. *The City as a Project*. Berlin: Ruby Press, pp. 70-100.
- Koller, S., 2013. Architects on Value: Reducing Ethics to Aesthetics?. In C. Basta, and S. Moroni, eds. *Ethics, Design and Planning of the Built Environment*. New York: Springer, pp. 57-75.
- Koskinen, I. et al., 2011. *Design Research Through Practice: From the Lab, Field and Showroom*, Waltham, MA: Elsevier.
- Kwinter, S., 2002. *Architectures of Time*, Cambridge MA: The MIT

- Press.
- Latour, B., and Yaneva, A., 2008. Give me a Gun and I will Make All Buildings Move: An ANT's View of Architecture. In R. Geiser, ed. *Explorations in Architecture: Teaching, Design, Research*. Basel: Birkhäuser, pp. 80-89.
- Latour, B., 2004a. *Politics of Nature: How to Bring the Sciences into Democracy*, Cambridge and London: Harvard University Press.
- Latour, B., 2004b. Why has Critique Run out of Steam? From Matters of Fact to Matters of Concern. In *Critical Inquiry*, Vol. 30, pp. 225-248.
- Law, J., 2004. *After Method, Mess in Social Science Research*, London and New York: Routledge.
- Leatherbarrow, D., 2001. Architecture Is Its Own Discipline. In A. Piotrowski, and J. W. Robinson, eds. *Discipline of Architecture*. Minnesota: University of Minnesota Press, pp. 83-102.
- Lefebvre, H., 1996. *Writings on Cities*, Oxford: Blackwell.
- Lefebvre, H., 2010. *Everyday life in the Modern World*, London: Athlone press.
- Lefebvre, P., 2014. Architecture and Pragmatism: Design Objects Made Moral. In *International Society for the Philosophy of Architecture*, [blog]. Available from <<http://isparchitecture.com>> (accessed 15 May 2017).
- Lefebvre, P., 2016. From Autonomy To Pragmatism: Objects Made Moral. In *The Journal for the International Society for the Philosophy of Architecture*, 2(1), pp. 23-37.
- Liekens, J., and Janssens, N., 2011. Matter Matters: Designing Material Encounters as Triggers of Negotiation. In *Nordic Design Research*, [blog]. Available from <<https://archive.nordes.org/index.php/n13/article/view/122>> (accessed on 12 September 2015).
- Maier, J.R.A., Fadel, G.M., and Battisto, G.D., 2009. An Affordance-based Approach to Architectural Theory, Design and Practice. In *Design Studies*, 30(4), pp. 393-414.
- Margolles, T., 2004. Santiago Sierra by Teresa Margolles. In *BOMB Magazine, Section Artists in Conversation*, [blog]. Available from <<http://bombmagazine.org/article/2606/santiago-sierra>> (accessed 15 June 2016).
- Martin, R., 2007. Critical of What? Towards a Utopian Realism. In W. S. Saunders, ed. *The new Architectural Pragmatism*. Minnesota: University of Minnesota Press, pp. 150-161.
- Maturana, H., and Varela, F., 1998. *The Tree of Knowledge*, Boston: Shambhala.
- Macarthur, J., and Stead, N., 2006. The Judge Is Not an Operator: Historiography, Criticality and Architectural Criticism. In *OASE*, Vol. 69, pp. 116-138.
- McNeill, W., 2006. Design and the Enigma of the World. In A. -M. Willis, ed. *Design Philosophy Papers*, Issue 2.
- Meisenheimer, W., 1984. Of the Hollow Spaces in the Skin of the Architectural Body. In *Deados*, Issue 13, pp. 103-111.
- Miessen, M., 2010. *The Nightmare of Participation*, Berlin: Sternberg

- Press.
- Mostafavi, M., and Leatherbarrow, D., 1993. *On Weathering: The Life of Buildings in Time*, Cambridge MA: The MIT Press.
- Mouffe, C., 2010. Democracy Revisited (In Conversation with Chantal Mouffe). In M. Miessen. *The Nightmare of Participation*. Berlin: Sternberg Press, pp. 105-160.
- Mouffe, C., 2012. Democratic Politics and Agonistic Public Spaces. In *Harvard Graduate School of Design Lectures*, [Video]. Available from <<http://www.youtube.com/watch?v=4Wpwwc25JRU>> (accessed 14 March 2015).
- Mouffe, C., 2013. *Agnostics: Thinking the World Politically*, London and New York: Verso.
- Nancy, J. -L., 2007. *The Creation of the World or Globalization*, Albany: The State University of New York Press.
- Nilsson, F., 2013. Making, Thinking, Knowing Architecture: Notes on Architecture as a Making Discipline and Material Practice. In J. Dehs, M. W. Esbensen, and C P. Pedersen, eds. *When Architects and Designers Write / Draw / Build / ? - Essays on Architecture and Design Research*. Aarhus: Arkitektskolens Forlag, pp.126-147.
- Nilsson, F., 2014. Making as Architectural Thinking and Practice. In A. Beim, and U. S. Madsen, eds. *Towards an Ecology of Tectonics: The Need for Rethinking Construction in Architecture*. Fellbach: Edition Axel Menges, pp. 82-97.
- Parr, A., 2005. *The Deleuze Dictionary*, Edinburgh: Edinburgh University Press.
- Perec, G., 1974., *Espèces d'Espaces*, Paris: Galilée.
- Pickering, A., 1995. *The Mangle of Practice: Time, Agency and Science*, Chicago: The University of Chicago Press.
- Rajchman, J., 1998. *Constructions*, London: The MIT Press.
- Rajchman, J., 2000. *The Deleuze Connections*, Cambridge MA: The MIT Press.
- Rancière, J., 1992. Politics, Identification, and Subjectivization. In J. Rajchman, ed. *The Identity in Question*. Cambridge MA: The MIT Press, pp. 58-64.
- Rancière, J., 2010. *Dissensus: On Politics and Aesthetics*, London: Continuum International Publishing Group.
- Rancière, J., 2011. The Thinking of Dissensus: Politics and Aesthetics, In P. Bowman, and R. Stamp, eds. *Reading Rancière*. London and New York: Continuum, pp. 1-17.
- Rendell, J., 1998. Doing it, (Un)Doing it, (Over)Doing it Yourself. In J. Hill, ed. *Occupying Architecture: Between the Architect and the User*. London: Routledge, pp. 229-246.
- Rendell, J., 2004. Architectural Research and Disciplinarity. In *Architectural Research Quarterly*, 8(2), pp. 141-147.
- Rendell, J. et al., 2007. *Critical Architecture*, London: Routledge.
- Robinson, R., 1994. Things that Make us Smart: Defending Human Attributes in the Age of the Machine. In *Design Issues*, 10(1). The MIT Press, pp. 77-79.

- Rossi, A., 1984. *A Scientific Autobiography*, Cambridge MA: The MIT Press.
- Rust, C., Mottram, J., and Till, J., 2007. *Review of Practice-led Research in Art, Design & Architecture*, Bristol: Arts and Humanities Research Council.
- Sassen, S., 2006. Making Public Interventions in Today's Massive Cities. In *Static*, Issue 04. Available from <http://static.londonconsortium.com/issue04/sassen_publicinterventions.php> (accessed 1 November 2014).
- Sassen, S., 2015. Public Interventions: The shifting Meaning of the Urban Condition. In *Archive Public*, [blog]. Available from <<https://archivepublic.wordpress.com/texts/saskia-sassen>> (accessed 3 March 2015).
- Schneider, T., and Till, J., 2009. Beyond Discourse: Notes on Spatial Agency. In I. Doucet, and K. Cupers, eds. *Agency in Architecture: Reframing Criticality in Theory and Practice*. Delft: Footprint, pp. 97-111.
- Schön, D. A., 1983. *The Reflective Practitioner: How Professionals Think in Action*, New York: Basic Books.
- Sennet, R., 2008. *The Craftsman*, London: Penguin Books.
- Shotter, J., 1993. *Cultural Politics of Everyday Life: Social Constructionism, Rhetoric and Knowing of the Third Kind*, Buckingham: Open University Press.
- Shusterman, R., 2010. *Soma-Esthétique et Architecture: Une Alternative Critique*, Genève: Haute Ecole d'Art et de Design.
- Simon, H. A., 1981. *The Sciences of the Artificial*, Cambridge MA: The MIT Press.
- Solà-Morales, M. de, Frampton, K., and Ibelings, K., 2008. *A Matter of Things*, Rotterdam: NAI 010 Publishers.
- Somol, R., and Whiting, S., 2007. Notes around the Doppler Effect and Other Moods of Modernism. In *Perspecta: Mining Autonomy*, Vol. 33. The MIT Press, pp. 72-77.
- Speaks, M., 2007. Design Intelligence. In M. Shamiyeh, ed. *Organizing for Change: Integrating Architectural Thinking in Other Fields*. Switzerland: Birkhäuser Architecture, pp. 11-18.
- Stagoll, C., 2005. Becoming. In A. Parr, ed. *The Deluze Dictionary*. Edinburgh: Edinburgh University Press, pp. 25-27.
- Sturrock, J., 1986. *Structuralism*, London: Paladin.
- Susani, M., 1992. The Fourth Kingdom. In *Ottogone Industrial Design Quarterly*, Issue 105, pp. 37-42.
- Teal, R., 2008. Immaterial Structures. In *Journal of Architectural Education*, 62(2), pp. 14-23.
- Teal, R., 2009. Residual Meaning: Assembling Thick Urbanism. In *Berkeley Planning Journal*, 22(1), pp. 126-137.
- Till, J., 2009. *Architecture Depends*, Cambridge MA: The MIT Press.
- Unger, R. M., 1987. *Social Theory: Its Situation and Its Task*, Cambridge: Cambridge University Press.
- Van Synghel, K., 2017. Leven Na de Betonstop. In *De Standaard: De Architect*, [newspaper article]. Available from <<https://www>>

- standaard.be/cnt/dmf20161211_02621381> (accessed 20 January 2018).
- Van Toorn, R., 2006. Aesthetics as a Form of Politics. In J. Seijdel, and L. Melis, eds. *Open! Art, Culture & the Public Domain*. Rotterdam: NAI 010 Publishers, pp. 54-61.
- Van Toorn, R., 2007. After Criticism: The Passion for Extreme Reality in Recent Architecture ... and its Limitations. In M. Shamiyeh, ed. *Organizing for Change: Integrating Architectural Thinking in Other Fields*. Switzerland: Birkhäuser Architecture, pp. 19-40.
- Varela, F., 1999. *Ethical Know-how: Action, Wisdom and Cognition*, Palo Alto, CA: Stanford University Press.
- Verbeke, J., 2006. The Sint-Lucas Research Training Sessions. In *Reflections*, Issue 3. Brussels and Ghent: Sint-Lucas School of Architecture.
- Vièrin, P., 2016. Hoekstenen. In C. Grafe, ed. *Architectuurboek Vlaanderen N°12: Architectuur op Maat*. Antwerpen: Vlaams Architectuurinstituut, pp. 51-58.
- Virilio, P., 1995. *The Art of the Motor*, Minneapolis: Minnesota University Press.
- Von Bush, O., 2009. Revisiting Affirmative Design. In *XXI magazine*, Issue 80. Available from <<http://selfpassage.org/XXI/XXI-0904/0904.htm>> on 03/03/2017> (accessed 2 May 2016).
- Von Busch, O., 2010. *Neighbourhoodies: Courageous Community Colours, Blazing Bling and Defiant Delight*, London: University of the Arts, College of Fashion.
- Wang, D., 2007. Diagramming Design Research. In *Journal of Interior Design*, 33(1), pp. 33-43.
- Wang, W. (director), and Auster, P. (writer/director), 1995. *Smoke*, [motion picture]. United States: Miramax.
- Williams, R., 1979. *Politics and Letters: Interview with New Left Review*, London: New Left Books.
- Yaneva, A., 2012. *Mapping Controversies in Architecture*, London: Routledge.
- Zeeuw, G. de, 2011. Improving Non-observational Experiences: Channelling and Ordering. In *Journal of Research Practice*, 7(2), Article M2. Available from <<http://jrp.icaap.org/index.php/jrp/article/view/273/242>> (accessed 14 October 2017).
- Ziman, J., 2000. *Real Science: What It Is, and What It Means*, Cambridge: Cambridge University Press.
- Žižek, S., 2011. Architecture and Aesthetics. In *University of Ljubljana Lectures*, [Video]. Available from <<https://www.youtube.com/watch?v=xdbiN3YcuEI>> (accessed 03 March 2017).

