

Modelling of non-uniform washcoat in catalytic monolith reactors

M. Walander^{1*}, J. Sjöblom^{1**}, D. Creaser², B. Lundberg³, S. Tamm⁴ and J. Edvardsson⁴

1: Mechanics and Maritime Sciences, Chalmers University of Technology, SE-412 96, Göteborg (Sweden)

2: Chemistry and Chemical Engineering, Chalmers University of Technology, SE-412 96, Göteborg (Sweden)

3: Volvo Car Corporation, SE-418 78, Göteborg (Sweden) 4: Johnson Matthey, SE-421 31, Göteborg (Sweden)

*magwal@chalmers.se, +4676 - 833 53 20, **jonas.sjoblom@chalmers.se

WASHCOAT CHARACTERIZATION

- Most 1+1d models assume uniform washcoat with global properties
- SEM (Scanning Electron Microscope) to approximate *global* and *local* porosity using *imageJ*
- IGA (Intelligent Gravimetric Analysis) to measure washcoat diffusivity [1]
- Input for parallel simulations to account for non-uniformity and tangential variations in properties

Sectionalizing principle, 3 sections

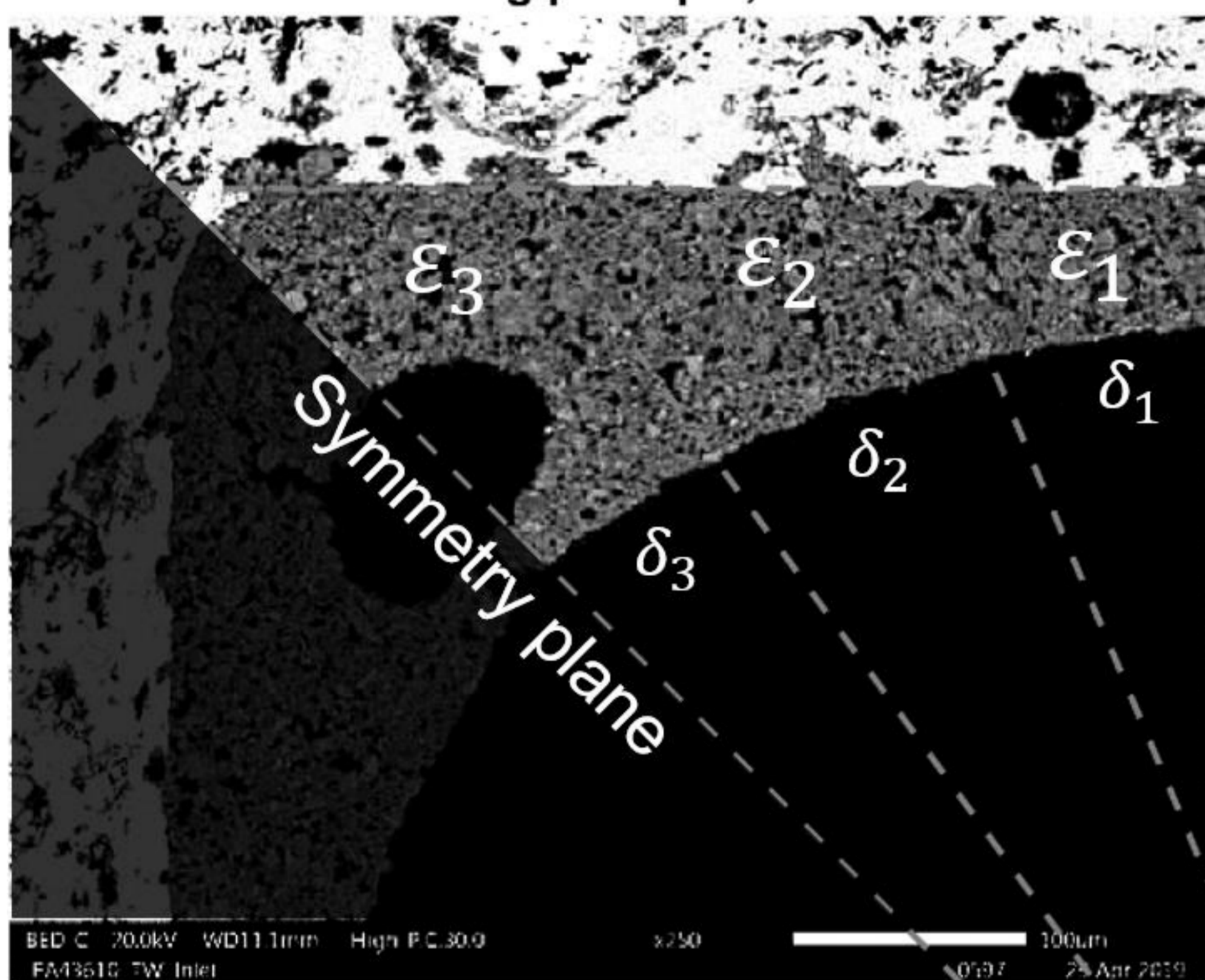

- Tortuosity, $\tau \approx 4$
- Porosity, $\epsilon \approx [0.81 \ 0.83 \ 0.86]$
- Unused washcoat showed up to 6.2 % higher local porosity in corners

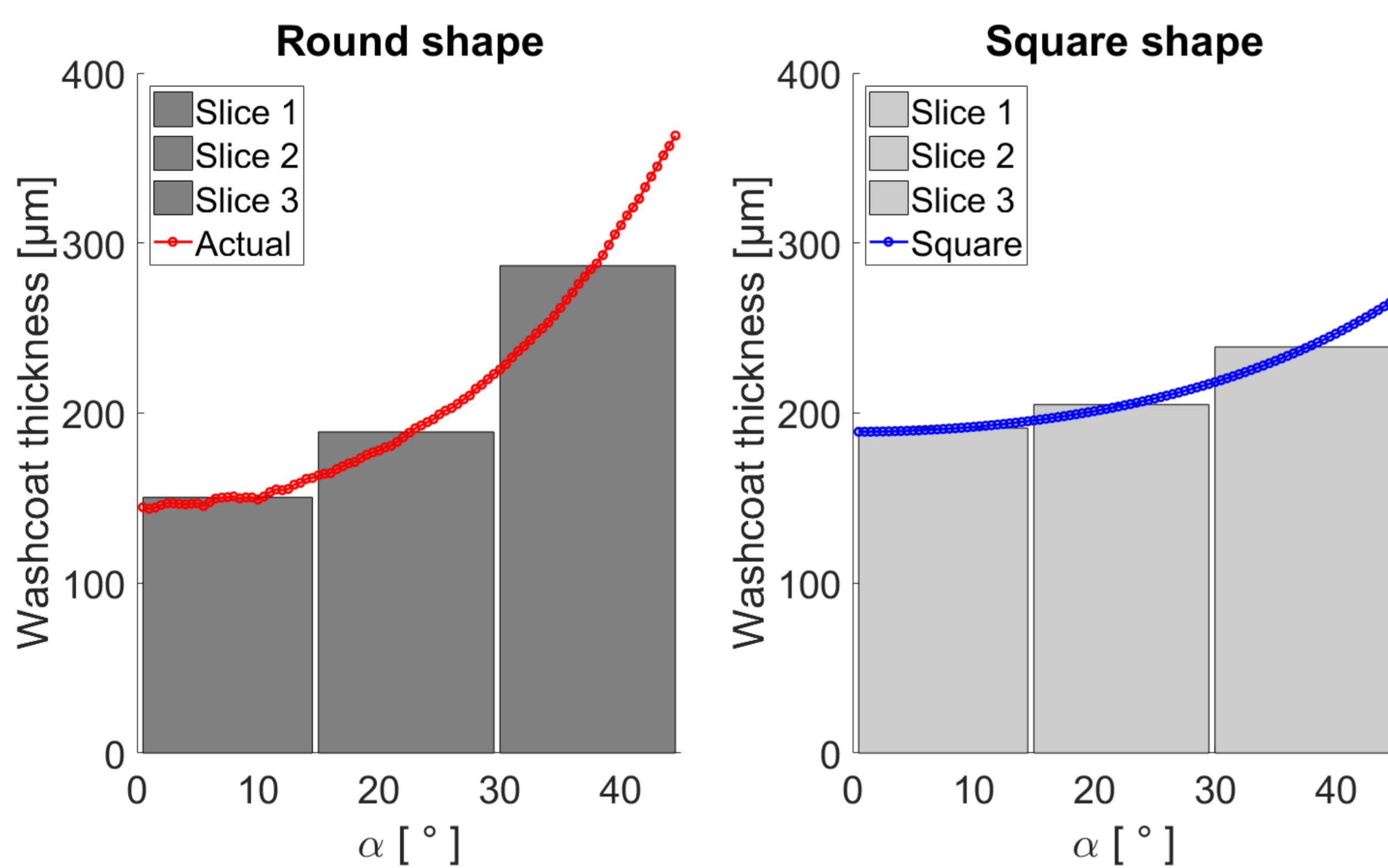

- Washcoat thickness, d_{wsc} 92 % higher in corners
- $N = 3$ slices gives good tradeoff

Acknowledgements: All project members along with the technical support at Johnson Matthey are deeply acknowledged for their help with performing and analyzing the experiments. The Swedish Energy Agency (FFI project 42814-1) is acknowledged for financial support.

PARALLEL 1+1D MODEL

- Sectioning principle based on equal angle
- Assumes no tangential mass transfer (between slices)

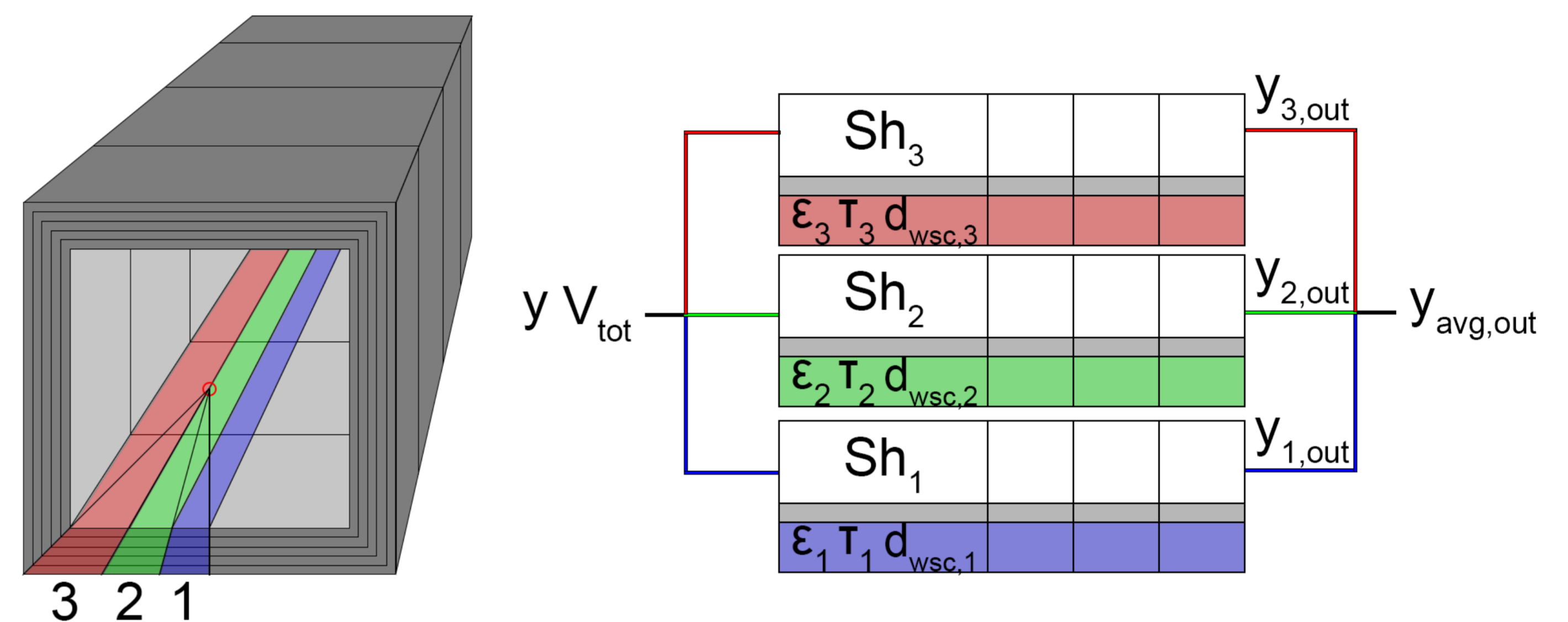

Light-off simulation 100 ppm NO

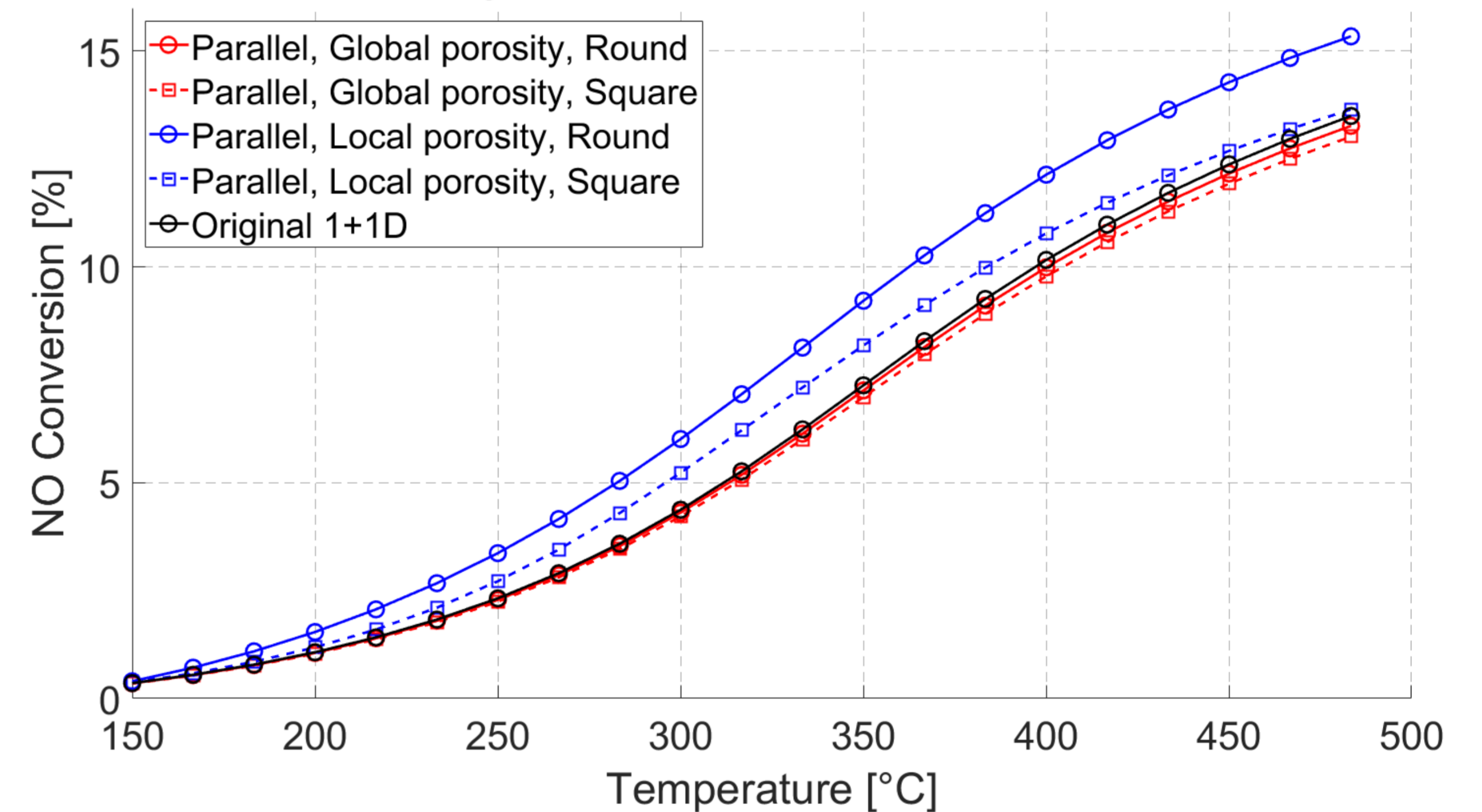

Tangential mass transfer

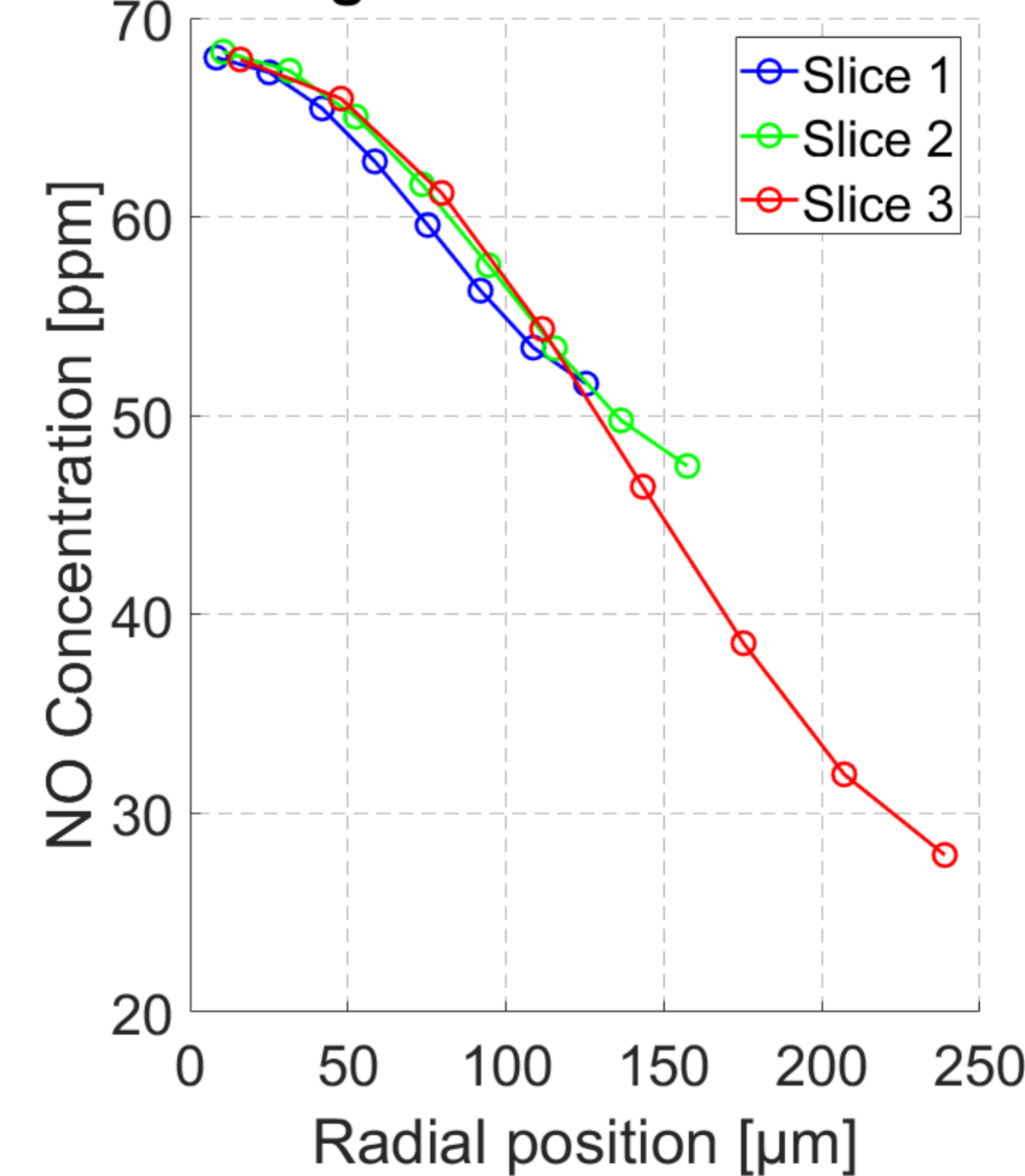

- Tangential concentration profiles are similar
- Ratio Radial : Tangential = 83
- Ratio Radial : Axial = 14 000

CONCLUSIONS

- IGA and SEM enabled tangentially resolved washcoat diffusivities – important for highly predictive reactor models.
- With global porosity, conversion decreases due to slightly thicker washcoat.
- With local porosity, conversion increases due to higher diffusivity in corners.

References:

[1] – Ruthven DM. Diffusion in type A zeolites: New insights from old data. Microporous and Mesoporous Materials. 2012;162:69-79.