

THESIS FOR THE DEGREE OF DOCTOR OF PHILOSOPHY

Environmental, Resource and Health Assessments of Hard Materials and
Material Substitution

The Cases of Cemented Carbide and Polycrystalline Diamond

ANNA FURBERG

Division of Environmental Systems Analysis

Department of Technology Management and Economics

CHALMERS UNIVERSITY OF TECHNOLOGY

Gothenburg, Sweden 2019

Environmental, Resource and Health Assessments of Hard Materials and
Material Substitution

The Cases of Cemented Carbide and Polycrystalline Diamond

ANNA FURBERG

ISBN 978-91-7905-236-2

© ANNA FURBERG, 2019.

Doktorsavhandlingar vid Chalmers tekniska högskola

Ny serie nr 4703

ISSN 0346-718X

Division of Environmental Systems Analysis

Department of Technology Management and Economics

Chalmers University of Technology

SE-412 96 Gothenburg

Sweden

Telephone + 46 (0)31-772 1000

Cover:

Picture illustrating the potential to substitute cemented carbide with polycrystalline diamond by comparing these materials from an environmental and resource perspective in a balance scale.

© Anna Furberg, 2019.

Chalmers Reproservice

Gothenburg, Sweden 2019

Environmental, Resource and Health Assessments of Hard Materials and
Material Substitution

The Cases of Cemented Carbide and Polycrystalline Diamond

ANNA FURBERG

Division of Environmental Systems Analysis

Department of Technology Management and Economics

Chalmers University of Technology

ABSTRACT

The conventional hard material used in manufacturing industry, cemented carbide (WC-Co), mainly consists of the geochemically scarce elements tungsten and cobalt. This use of scarce resources could potentially be avoided by a material substitution to the more abundant and largely carbon-based material polycrystalline diamond (PCD). The aims of this thesis are to (i) assess environmental, resource and health impacts of WC-Co, (ii) assess environmental and resource impacts of PCD and (iii) assess the environmental and resource potential of substituting WC-Co with PCD. For fulfilling these aims, life cycle assessment (LCA) and material flow analysis (MFA) are applied.

Papers I-III show that WC-Co has notable environmental, resource and health impacts. LCA results for non-Chinese WC-Co production show that most environmental impacts are dominated by a limited number of inputs and outputs (e.g. kerosene, sulfidic tailings and electricity) (Paper I). MFA results for flows of tungsten in the specific product of passenger car tire studs made from WC-Co show that the recycling of tungsten in this product is non-existing (0%) and thus considerably lower than the global average (10-25%) (Paper II). Net health impact results for tire studs in a studded Scandinavian passenger car show that the purpose of tire studs – to prevent injuries – is not justified since the negative health impacts, mainly due to emissions of road particles during use, outweigh the positive health impacts from accident reduction (Paper III).

Paper IV provides LCA results for PCD production and compares WC-Co and PCD tools regarding environmental and resource impacts in the specific applications of wood working and titanium machining. The results show that PCD is preferable in wood working but not in titanium machining. In Paper V, a framework for defining functional units in comparative LCAs of materials is presented. The framework outlines three functional unit types: the reference flow, material property and product performance types. The selected functional unit greatly affects the result when comparing WC-Co to PCD. The main methodological contributions of this thesis are the inclusion of negative health impacts associated with conflict minerals in Paper III and the framework for comparative LCAs of materials in Paper V.

Keywords: Life cycle assessment, material flow analysis, disability-adjusted life years, cemented carbide, polycrystalline diamond, machining tools

Miljö-, resurs- och hälsobedömningar av hårda material samt materialsubstitution
Exemplen hårdmetall och polykristallin diamant
ANNA FURBERG
Avdelningen för miljösystemanalys
Institutionen för teknikens ekonomi och organisation
Chalmers tekniska högskola

SAMMANFATTNING

Det konventionella hårda materialet inom tillverkningsindustrin är hårdmetall (WC-Co), vilket huvudsakligen består av de knappa materialen volfram och kobolt. Denna användning av knappa resurser skulle potentiellt kunna undvikas genom materialsubstitution från WC-Co till mer vanligt förekommande och till stor del kolbaserade material såsom polykristallin diamant (PCD). Målen med denna avhandling är att (i) utvärdera miljö-, resurs-, och hälsopåverkan av WC-Co, (ii) utvärdera miljö- och resurspåverkan av PCD samt (iii) utvärdera miljö- och resurspotentialen av att substituera WC-Co mot PCD. För att uppfylla dessa mål används metoderna livscykelanalys (LCA) och materialflödesanalys (MFA).

Artikel I-III visar att WC-Co har betydande miljö-, resurs- och hälsopåverkan. LCA-resultat för produktion av WC-Co utanför Kina visar att de flesta miljöpåverkans-kategorier domineras av ett begränsat antal in- och utflöden (såsom fotogen, sulfidinnehållande anrikningssand och elektricitet) (Artikel I). MFA-resultat för flöden av volfram i den specifika produkten personbilsdubbar, som innehåller WC-Co, visar att återvinning av volfram för denna produkt är icke-existerande (0%) och därför betydligt lägre än det globala genomsnittet för återvinning av volfram (10-25%) (Artikel II). Resultat för netto-hälsopåverkan kopplat till användningen av dubbar i en skandinavisk personbil med dubbdäck visar att dubbarnas syfte – att förhindra olyckor – inte uppfylls eftersom den negativa hälsopåverkan, främst kopplad till slitage av vägpartiklar vid användning, överstiger den positiva hälsopåverkan från olycksminskning (Artikel III).

Artikel IV innehåller LCA-resultat för PCD-produktion samt jämför miljö- och resurspåverkan från WC-Co- och PCD-verktyg för de specifika applikationerna trä- och titanbearbetning. Resultaten visar att PCD är att föredra vid bearbetning av trä men inte titan. Artikel V presenterar ett ramverk för definition av funktionella enheter i LCA vid jämförelser av material. Ramverket specificerar tre typer av funktionella enheter: referensflöde, materialegenskaper och produktprestanda. Valet av funktionell enhet påverkar i hög grad resultatet vid en jämförelse mellan WC-Co och PCD. Denna avhandlingens huvudsakliga metodologiska bidrag är inkludandet av negativ hälsopåverkan från konfliktmineraler i Artikel III och ramverket i Artikel V.

Nyckelord: Livscykelanalys, materialflödesanalys, funktionsjusterade levnadsår, hårdmetall, polykristallin diamant, bearbetningsverktyg

LIST OF PUBLICATIONS

This thesis is based on the work contained in the following papers:

- I. Furberg, Anna; Arvidsson, Rickard; Molander, Sverker. 2019. Environmental life cycle assessment of cemented carbide (WC-Co) production. *Journal of Cleaner Production* 209, 1126-1138
- II. Furberg, Anna; Arvidsson, Rickard; Molander, Sverker. 2019. Dissipation of tungsten and environmental release of nanoparticles from tire studs: A Swedish case study. *Journal of Cleaner Production* 207, 920-928
- III. Furberg, Anna; Arvidsson, Rickard; Molander, Sverker. 2018. Live and let die? Life cycle human health impacts from the use of tire studs. *International Journal of Environmental Research and Public Health* 15(8), 1774-1785
- IV. Furberg, Anna; Fransson, Kristin; Zackrisson, Mats; Larsson, Mikael; Arvidsson, Rickard. 2019. Environmental and resource aspects of substituting cemented carbide with polycrystalline diamond: The case of machining tools. Submitted to *Carbon*
- V. Furberg, Anna; Arvidsson, Rickard; Molander, Sverker. 2019. A framework for defining functional units in comparative life cycle assessments of materials. Submitted to *International Journal of Life Cycle Assessment*

Other related publications

1. Furberg, Anna; Arvidsson, Rickard; Larsson, Mikael; Zackrisson, Mats; Fransson, Kristin; Molander, Sverker. "What are the Life Cycle Environmental Impacts of Synthetic Diamond?" 30th International Conference on Diamond and Carbon Materials, Seville, Spain, 8-12 September 2019
2. Furberg, Anna; Arvidsson, Rickard; Larsson, Mikael; Zackrisson, Mats; Fransson, Kristin; Molander, Sverker. "Life Cycle Environmental Impacts of Synthetic Diamond Production". SETAC Europe 29th Annual Meeting. "One Environment. One Health. Sustainable Societies." Helsinki, Finland, 26-30 May 2019
3. Furberg, Anna; Arvidsson, Rickard; Molander, Sverker. "Societal flows of cemented tungsten carbide – the case of tire studs". Towards Nanotech Safety Mistra Environmental Nanosafety conference, Gothenburg, Sweden, 13-15 November 2018
4. Furberg, Anna; Arvidsson, Rickard; Molander, Sverker. "Using DALY for Assessing Human Health Impacts of Conflict Minerals". 6th International Conference on Social Life Cycle Assessment, Pescara, Italy, 10-12 September 2018
5. Furberg, Anna; Arvidsson, Rickard; Molander, Sverker. "Do tire studs in cars save or take lives? A life cycle assessment on human health impacts". 8th International Conference on Life Cycle Management, Luxembourg, Luxembourg, 3-6 September 2017
6. Furberg, Anna; Arvidsson, Rickard; Molander, Sverker. "Quantifying emissions and environmental risks of cemented carbide (WC-Co) nanoparticles from tire studs". 11th International Conference on the Environmental Effects of Nanoparticles and Nanomaterials, Golden, Colorado, 14-18 August 2016
7. Furberg, Anna; Arvidsson, Rickard; Molander, Sverker. "Towards circular flows of tungsten – Characterizing dissipation". Future Circular Materials Conference, Gothenburg, Sweden, 11-12 May 2016
8. Furberg, Anna; Arvidsson, Rickard; Molander, Sverker. "Assessing impacts of tungsten carbide: A substance and particle flow analysis". 8th Biennial Conference of the International Society for Industrial Ecology, Surrey, United Kingdom, 7-10 July 2015

ACKNOWLEDGEMENTS

I would like to gratefully acknowledge the support and encouragement provided by my supervisors Rickard Arvidsson and Sverker Molander during the work on this thesis. I would also like to thank all my colleagues at the division of Environmental Systems Analysis for a great workplace environment. The financial support from Mistra Environmental Nanosafety Phase I and II, funded by the Swedish Foundation for Strategic Environmental Research (Mistra), is gratefully acknowledged. At last, but definitely not least, a special thanks goes to my family and friends for their support and encouragement.

TABLE OF CONTENTS

1	INTRODUCTION.....	1
1.1	Material substitution.....	1
1.2	Hard materials.....	2
1.2.1	Cemented carbide (WC-Co).....	3
1.2.2	Polycrystalline diamond (PCD).....	5
1.2.3	Cemented carbide and polycrystalline diamond tools.....	5
1.3	Aims and research questions.....	6
2	METHODS.....	9
2.1	Life cycle assessment (LCA).....	9
2.1.1	Disability-adjusted life years (DALY).....	12
2.2	Material flow analysis (MFA).....	13
3	RESULTS AND DISCUSSION.....	17
3.1	Environmental, resource and health impacts of WC-Co.....	17
3.2	Environmental and resource impacts of PCD.....	22
3.3	Environmental and resource potential for substituting WC-Co with PCD.....	23
3.4	Reflections on data gathering.....	26
4	CONCLUSIONS AND RECOMMENDATIONS.....	29
4.1	Environmental, resource and health impacts of WC-Co.....	29
4.2	Environmental and resource impacts of PCD.....	29
4.3	Environmental and resource potential for substituting WC-Co with PCD.....	29
4.4	The importance of a life cycle perspective in material substitution.....	30
4.5	Early assessments of material substitution.....	31
4.6	Material substitution and social aspects.....	32
5	REFERENCES.....	35

1 INTRODUCTION

1.1 Material substitution

One of the most critical challenges facing humanity is the sustainable handling of the Earth's resources. The use of resources, such as materials in various technologies, have enabled the current state of life in contemporary societies, but is also associated with large impacts on the environment, long-term resource availability as well as human health (Lubchenco, 1998; Graedel et al., 2015). Thus, a question of utmost importance to address in the strive towards a more sustainable society is: *What materials should be used and how should these materials be used in order to reduce society's environmental and resource impacts?* Different strategies exist to obtain a sustainable handling of resources, with two major ones being dematerialization and transmaterialization (Figure 1). Dematerialization means a decline of material use per unit of service output, which can be achieved by e.g. reuse, recycling and/or reduced demand for materials (De Bruyn, 2002; Van Der Voet et al., 2005). Thus, energy as well as the amounts of material inputs and outputs associated with a specific product or service become reduced. In society, dematerialization can be a result of technological changes, such as increased efficiencies, and/or structural changes, such as altered consumption patterns due to life-style changes (De Bruyn, 2002). The concept of circular economy, which combines reduce, reuse and recycle activities (Kirchherr et al., 2017), lies close to the concept of dematerialization.

Transmaterialization, on the other hand, means that materials become substituted with other materials (Labys, 2002). Typically, conventional materials are substituted by novel materials that might bring increased quality or more advanced technological features. Thus, applying the strategy of transmaterialization, conventional materials associated with higher impacts can be substituted with novel, lower-impact materials. This differs from the strategy of dematerialization, where the focus commonly lies at optimizing the process system, typically via recycling, of the conventional material. Chemical risk assessment (van Leeuwen and Vermiere, 2007), when applied to compare chemicals and provide information on substitution potentials, and the concept of substituting toxic chemicals with less toxic ones (Löfstedt, 2014), both lie close to transmaterialization. However, substitution might not only occur to reduce toxicity, but also to reduce the use of scarce resources (Graedel et al., 2015; Arvidsson and Sandén, 2017). While dematerialization focuses on *how* materials should be used, transmaterialization focus more on *what* materials should be used. Although the *what* question logically precedes the *how* question, the main strategy applied for obtaining a sustainable handling of resources today is typically via dematerialization. This thesis is instead about material substitution and the question of what materials should be used in order to reduce environmental and resource impacts. The specific focus is on hard materials, which are utilized in society because of their high toughness and hardness. In Section 1.2, the case of comparing WC-Co and PCD hard materials is motivated, knowledge gaps are described, and the research questions answered in this thesis are then presented in Section 1.3.

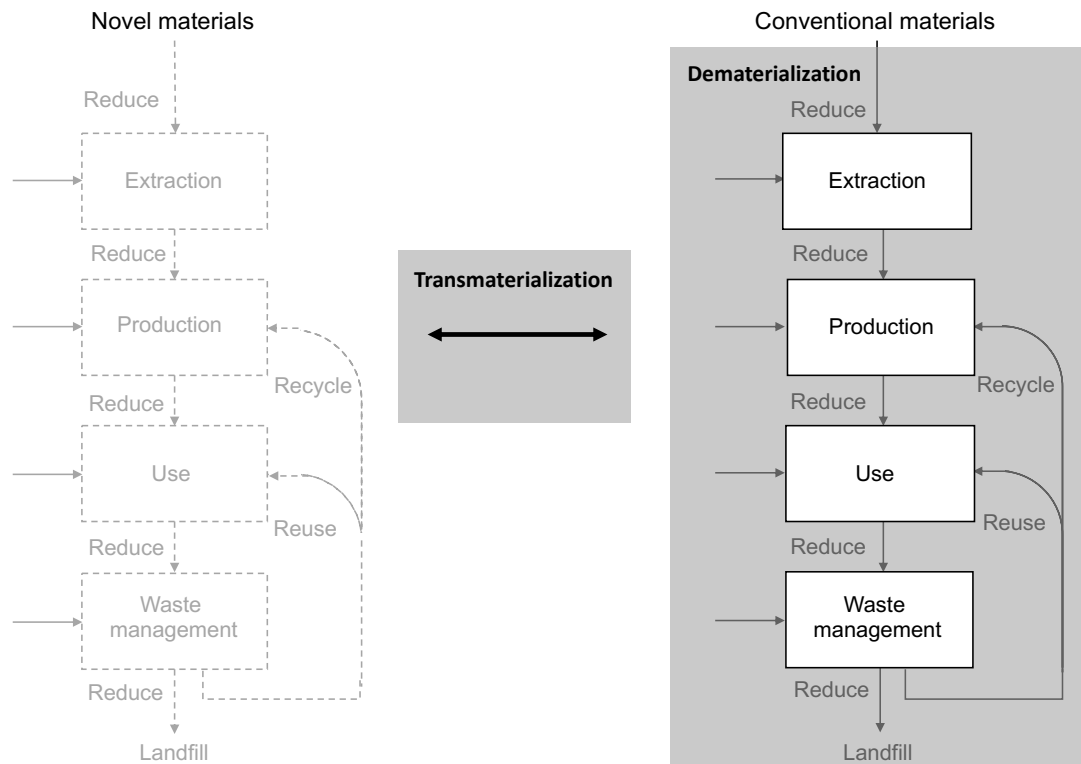

Figure 1. Illustration of the life cycles of novel and conventional materials and the strategies of dematerialization and transmaterialization for sustainable handling of resources. The typical focuses of these strategies are highlighted in grey

1.2 Hard materials

The importance of hard materials for society is reflected by the fact that entire civilizations have been shaped by, and historical time periods have been named after, the predominant hard material being used at that time (e.g. the stone, bronze and iron ages) (Hummel, 2004). Hard materials are of crucial importance for manufacturing and the hard materials applied in today's society include, in addition to the more conventional steels, cemented carbides, cermets and so-called superhard materials (Sarin, 2014). Some examples of contemporary hard materials are provided in Table 1. Cemented carbides, also called hard metals, combine a hard and wear-resistant phase, mainly tungsten carbide, with a metallic phase, typically cobalt (Prakash, 2014). Cermets, i.e. ceramic particles bonded with a metal matrix, include for example carbides, nitrides and carbonitrides of titanium, tantalum and molybdenum (Ettmayer et al., 2014). The hardest materials of these hard material groups are the superhard materials, which include for example diamond and cubic boron nitride (Lowther, 2014). Cemented carbide is the dominating hard material today while the use of cermets and superhard materials is currently limited to niche markets (Prakash, 2014; Konstanty, 2005). However, the trend is towards an increased use of superhard materials and specifically diamond in the form of polycrystalline diamond (PCD) in cutting tools (Bobzin, 2017).

In general, diamond tools enable faster cutting, more accurate and less costly operations and have therefore been adopted in industries such as wood working, stone cutting, metal cutting and machining of ceramics (Konstanty, 2005; USGS, 2018b). PCD, specifically, competes with conventional cutting tools, including cemented carbides, in applications where high hardness is of utmost importance (Konstanty, 2014a; Konstanty, 2005).

Table 1. Hardness, typically determined by ISO standardized tests such as the Vickers hardness (HV) test, and compressive strength for a number of hard materials (Fang et al., 2014; Prakash, 2014). WC-Co=cemented tungsten carbide with cobalt, TiC= titanium carbide, SiC=silicon carbide, c-BN=cubic boron nitride

Material group	Material	Hardness (Vickers hardness) [HV]	Compressive strength (Young's modulus) [GPa]
Steels	Steel	240-300	150-200
	High-speed steel	750-800	210
Cemented carbide	WC-Co	700-2200	400-650
	TiC	1500-2200	460
Cermets	SiC	2300-2600	400-460
	c-BN	4000	~400
Superhard materials	Diamond	8000-10 000	1220

1.2.1 Cemented carbide (WC-Co)

The conventional hard material of WC-Co is the typical choice in applications where wear resistance, toughness and strength are required at higher temperatures (Prakash, 2014). WC-Co constitutes the backbone of today's tool manufacturing industry and the importance of this material for the manufacturing industry is demonstrated by the fact that about 70% of metal cutting tools are made from this material (Fang et al., 2014). The applications of WC-Co are found in a broad range of areas, including cutting tools, rock drilling tools, mining and construction and wear parts (Fang et al., 2014). However, at the same time, WC-Co is marked with environmental and resource issues. Globally, China dominates the tungsten production, but partly due to poor tungsten carbide quality (Ma et al., 2017), the WC-Co that is purchased outside China is more likely to originate from non-Chinese production. Existing life cycle inventory (LCI) data for WC-Co was previously limited to a few studies. Ma et al. (2017) considered WC production in China, where other production technologies are applied compared to non-Chinese WC-Co production (Wolfe et al., 2014). Syrrakou et al. (2005) considered non-Chinese production but only included input materials, while energy requirements, emissions and waste were omitted. Xiong et al. (2008) only included a few processes of the whole life cycle in their study on laboratory-scale production of a WC-Co component. Despite a

still notable global recycling of tungsten at the rate of 10-25% globally (Graedel et al., 2011), none of these LCI data sets included recycling. Other available LCA studies with tungsten as an important input material are largely based on these previously-mentioned, limited datasets (Bobba et al., 2016; Wigger et al., 2017). Thus, existing LCI data on WC-Co production was, prior to the work within this thesis, limited and did not adequately represent non-Chinese WC-Co production.

The main constituents of WC-Co, being tungsten and cobalt, are geochemically scarce (1 and 24 ppm in the Earth's crust, respectively (Wedepohl, 1995)). Their global production is dominated by single countries: China (>80% for tungsten (USGS, 2018a)) and the Democratic Republic of the Congo (DRC) (50% for cobalt (USGS, 2017)). These metals have furthermore been identified as critical raw materials for the European Union (EU) due to their supply risk and economic importance (European Commission, 2017). It is not only the limited availability of its constituents that causes resource issues related to the use of WC-Co. The use of tungsten, which is the main element by mass in WC-Co, is largely dissipative (>60% globally), implying that tungsten is lost, e.g. released to the environment, landfilled or diluted in other material flows, in ways that makes it technically or economically unfeasible to recover (Zimmermann and Gößling-Reisemann, 2013). At the same time, the functional recycling rate of tungsten, i.e. the rate at which tungsten is returned to a product or material where it has a specific function to fulfil (Guinée et al., 1999), is limited to 10-25% globally (Graedel et al., 2011). In order to be able to identify and implement measures to reduce dissipative losses, it is important with information on product-specific material flows (Zimmermann, 2015; Zimmermann, 2017). This is especially important since the dissipation of specific products might vary significantly from average values for the material. However, available studies on tungsten's societal metabolism prior to the work within this thesis typically did not focus on specific products but on the national or global level (Leal-Ayala et al., 2015; Harper and Graedel, 2008; Wang et al., 2018).

In addition to the aforementioned environmental and resource issues, the mining of tungsten, together with tin, titanium and gold (together referred to as the 3TGs) have been associated with the conflict in the DRC since revenues from such mining finance civil warfare in the region and are therefore denoted as conflict minerals (Young, 2018). Cobalt mined in the DRC is also associated with the conflict (Sovacool, 2019). DRC's share of the global mine production of tungsten is limited (USGS, 2018a), while the global mining of cobalt is dominated by the DRC (USGS, 2017), where artisanal miners work under harsh conditions (Elenge et al., 2013). Artisanal mining is in general a very dangerous activity and fatal accidents are commonly occurring (ILO, 1999). Previous studies on net health impacts of products included an airbag system (Baumann et al., 2013), nano-enabled chemical gas sensors (Gilbertson et al., 2014) and infrastructure for air pollution emission reduction (Kobayashi et al., 2017). These studies made use of the

disability-adjusted life years (DALY) indicator to quantify net human health impacts. The net impacts of WC-Co products, including both positive human health impacts, e.g. from avoiding injuries, and negative human health impacts, e.g. from occupational accidents and life cycle production emissions, had not been assessed prior to the work within this thesis.

1.2.2 Polycrystalline diamond (PCD)

Commercial production of PCD is conducted by consolidating synthetic diamond powder, i.e. crushed diamond grit, and cobalt powder at high temperatures and pressures (Konstanty, 2005). Diamond grit is typically produced via high-pressure high-temperature (HPHT) synthesis (Kasu, 2016; Kesler and Simon, 2015). In contrast to the main constituent in WC-Co of tungsten, the main constituent in PCD, being carbon, is comparatively abundant (1990 ppm in Earth's crust) (Wedepohl, 1995). Cobalt is present in both WC-Co and PCD, although not as their main constituent. LCA results for the industrial production of PCD and for conventional synthetic diamond production of diamond grit via high-pressure high-temperature (HPHT) synthesis were previously missing. LCA results were presented for laboratory synthetic diamond production via the hot filament chemical vapor deposition (HF-CVD) synthesis route (Wilfong et al., 2012). Ferreira et al. (2019) furthermore presented LCI data for a master alloy containing detonation nanodiamonds but not for the production of nanodiamonds, specifically. However, these previous LCA results did not represent industrial diamond grit production but the production of other types of diamond, i.e. diamond layer and nanodiamond. Thus, LCA results for industrial PCD production and for the HPHT production of its precursor, diamond grit, had been missing prior to the work within this thesis.

1.2.3 Cemented carbide and polycrystalline diamond tools

There are indications that diamond tools could constitute an environmentally more sustainable alternative compared to conventional tools beyond the use of the geochemically abundant carbon, since they also tend to have longer lifetime and provide improved machining properties (Aurich et al., 2013; Mendoza et al., 2014). However, the scope of previous studies suggesting this have been limited to the use phase and not considering the whole life cycle of the tools. Thus, there are indications that PCD could be preferable, both considering environmental and resource aspects, compared to WC-Co, but whether this is true from a life cycle perspective had not been investigated prior to the work within this thesis. A comparative LCA of the use of PCD and WC-Co tools in specific machining applications had not been provided previously. Thus, the environmental and resource prospects of substituting WC-Co tools with PCD tools also remained to be assessed. In comparative LCAs of materials, the definition of the functional unit, which is a measure of the performance of the functional outputs of the product system (ISO, 2006), is important. For some types of products, specifying a functional unit can be challenging. In studies guiding material selection, specifically, the

compared materials are seldom fully identical as they commonly differ in their qualities or functions. General recommendations on the definition of functional units in comparative LCAs were previously provided by international standards (ISO, 2006) and other LCA guidelines (European Commission, 2010), as well as the scientific literature on LCA methodology (Cooper, 2003; Reap et al., 2008; Hetherington et al., 2014). These general recommendations included defining multiple functional units that focus on different functions and having a clarity in the study's goal. However, concrete recommendations on how to define the functional unit, or what type of functional unit to apply in different situations, had not been provided previously. At the same time, functional equivalence is sometimes stated as a prerequisite for comparative LCAs since the lack of equal functions might cause product comparisons to be unreasonable and unfair (European Commission, 2010). However, it is not possible to have complete functional equivalence in comparative LCAs of materials since different materials always have at least slightly different properties and product performances. Consequently, concrete recommendations on how to specify functional units in comparative LCAs of materials, as well as recommendations on when the application of different types of functional units are relevant, would be useful in order to handle the ever-present (although sometimes slight) differences between materials. Such concrete recommendations had not been provided prior to the work within this thesis.

1.3 Aims and research questions

While information about the price and technical performance of materials are commonly known and acknowledged, as exemplified by statements on the exceptional compromise between price and performance of tungsten (European Commission, 2017), environmental and resource impacts have not been equally considered. For hard materials, there is a trend towards substituting the conventional WC-Co with PCD but previously, potential trade-offs between environmental and resource impacts of WC-Co and PCD in such a substitution have not been assessed. Additionally, information on environmental and resource impacts of WC-Co and PCD, which is a prerequisite for such assessments, has been missing prior to the work within this thesis. The overarching theme of this thesis is the assessment of material substitution, focusing on WC-Co and PCD hard materials. The first aim of this thesis is to assess environmental, resource and human health impacts related to the currently dominating hard material WC-Co. The second aim is to assess environmental and resource impacts related to the novel, and largely carbon-based hard material PCD. The third aim is to assess the environmental and resource potential for substituting WC-Co with PCD. In such assessments of substitutions, comparability in terms of properties and performance is a particularly important yet challenging issue. In order to fulfill these aims, this thesis answers three specific research questions (corresponding to the knowledge gaps identified in Section 1.2.1-1.2.3):

1. What are the environmental, resource and human health impacts of the conventional hard material WC-Co?

2. What are the environmental and resource impacts of the novel hard material PCD?
3. What is the environmental and resource potential for substituting WC-Co with PCD?

The overarching approach to the assessment of material substitution in this thesis, the research questions and their connection to the appended Papers I-V are illustrated in Figure 2. The need for an environmental systems perspective is clear considering the numerous environmental and resource issues discussed in Section 1.2. An environmental systems perspective thus constitutes the point of departure in this thesis, why the environmental systems analysis methods life cycle assessment (LCA) and material flow analysis (MFA) (Finnveden and Moberg, 2005) are applied. These methods are further described in Section 2.

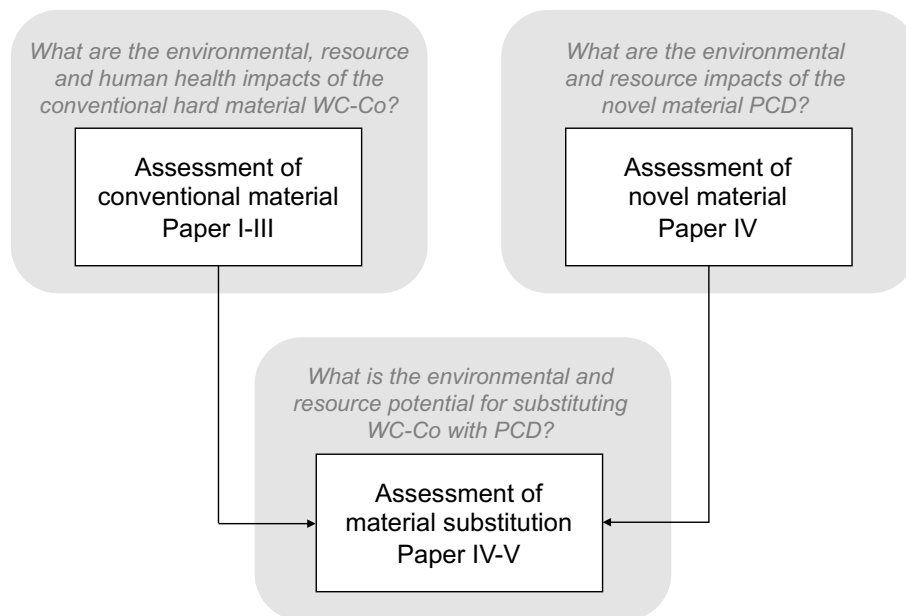

Figure 2. Overarching approach to assess environmental and resource impacts of material substitution in this thesis, illustrating the connections between the research questions and the appended papers

2 METHODS

The two main methods used in this thesis are LCA and MFA, which are two methods belonging to the family of environmental systems analysis methods (Finnveden and Moberg, 2005) and also to the larger family of sustainability assessment methods (Ness et al., 2007). They are furthermore part of the industrial ecology toolbox (Ayres and Ayres, 2002). The LCA and MFA methods are described below. In addition, the concept of DALY, which has been borrowed into the LCA field from global burden of disease studies, is central to Paper III and therefore described in more detail as well.

2.1 Life cycle assessment (LCA)

In a comparison of materials, it is important to identify which materials that perform better from an environmental and resource perspective and to clarify potential trade-offs. For example, a substitution from a material based on scarce elements to an energy-intensive material might cause an undesired trade-off between resource and environmental impacts. The method of LCA can be used to assess life-cycle environmental impacts of products and services, and is commonly applied in order to avoid sub-optimization and to identify trade-offs (Finnveden et al., 2009). The method was developed much through work within the Society of Environmental Toxicology and Chemistry (SETAC), leading up to the publication of their “code of practice” (Consoli et al., 1993). An ISO standard was constructed for LCA in 1997 and it was updated in 2006 to approximately describe the method as it is put into practice today (ISO, 2006). The use of LCA has much increased since the days of its early development (Guinée et al., 2011). Typical applications of LCA include to aid in environmental impact reductions of products and services as well as the provision of support for marketing and strategic decisions. In addition to assessing products and services, LCA can have other scopes as well, including processes, organizations, consumer lifestyles and countries (Hellweg and Milà i Canals, 2014). LCA studies can furthermore cover various parts of the life cycle, e.g. the raw material extraction phase to the production phase (cradle-to-gate) or the raw material extraction phase over production and use to the waste management phase (cradle-to-grave) (Baumann and Tillman, 2004).

The LCA framework consists of four steps, including the goal and scope definition, inventory analysis, impact assessment and interpretation (Figure 3) (ISO, 2006). These steps are interconnected and typically conducted in an iterative manner as illustrated in Figure 3. Note that substantial development of LCA has taken place over the last three decades, which has widened the focus on environmental impacts into also considering economic (in the method life cycle costing (LCC)) and social impacts (in the method social life cycle assessment (SLCA)) (Guinée et al., 2011). The focus in this section, however, lies on LCA of environmental impacts.

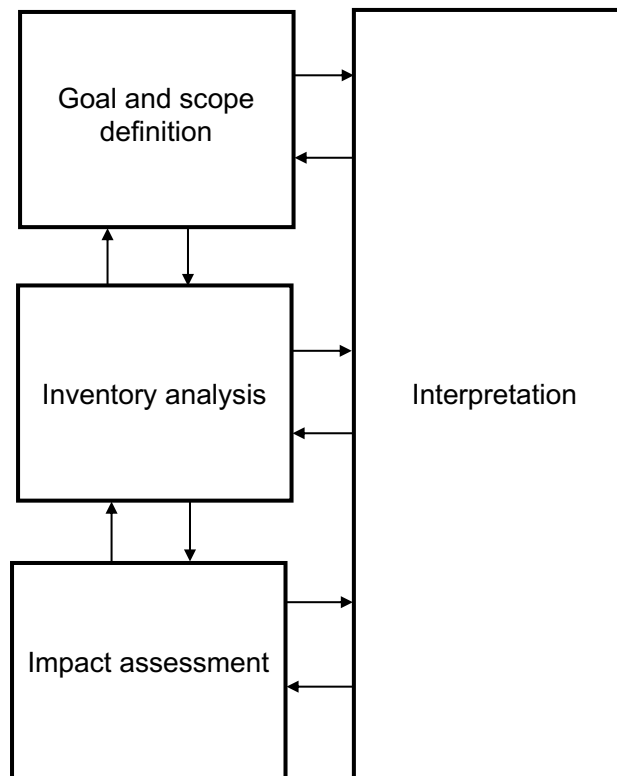

Figure 3. The four steps in the LCA framework (ISO, 2006)

The *goal and scope definition* includes deciding upon the study's purpose, the object of the study (e.g. a specific product), the functional unit, system boundary, the included environmental impacts and specifying the intended audience. The functional unit describes the function of the studied products. A functional unit could, for example, be 1 kg steel or 1 kg workpiece material removed by a tool and should be selected to allow for a relevant and fair comparison to other products. The selection of the system boundary is about deciding which processes to include in the product system of the study. All subsequent methodological choices in an LCA should be guided by the decisions made in the goal and scope definition step (Tillman, 2000). In the *inventory analysis*, a set of life cycle inventory (LCI) data for the studied system is obtained by relating data on material and energy inputs, by-products as well as outputs, in the form of emissions and waste, to the functional unit. This is done via mass and energy balance calculations. Furthermore, a flowchart is constructed, which illustrates the system studied and the included processes according to the selected system boundary. LCI data compilation can be conducted in different ways, including the application of a process-flow diagram and algebra to link data on amounts of inputs and outputs to the functional unit, which is the most common way, but matrix representation of the product system and input-output analysis can also be applied (Suh and Huppel, 2005). It is furthermore in this step that allocation of flows between different products (the main product and by-products) is conducted, typically by any of the following approaches:

- Avoiding allocation by system expansion, which might involve substitution (or displacement) of other products (Vadenbo et al., 2017)
- Allocation based on physical properties, such as mass or energy content
- Allocation based on economic value, such as market prices (Guinée et al., 2004)

Impact assessment involves the quantification of the impacts associated with the inventory data. To enable this quantification, impact categories need to be selected already in the goal and scope definition phase, with examples including global warming, ozone depletion, acidification, eutrophication, energy use and abiotic resource depletion. An impact category should be linked to damage on the natural environment, natural resources and/or human health (Finnveden et al., 2009), which are the three main areas of protection considered in LCA. In the impact assessment, the LCI data is then classified into the selected impact categories. The translation (specifically called characterization) from LCI data, e.g. elementary input and output flows, to midpoint impact categories is conducted by the application of characterization factors (CF) according to (Hauschild and Huijbregts, 2015):

$$IS = \sum_i CF_i \cdot q_i \quad \text{Eq. 1}$$

where IS is the final impact score [e.g. CO₂ eq], CF_i is the midpoint characterization factor for impact category i [e.g. kg CO₂ eq/kg substance] and q_i is the quantity of an input or output [e.g. kg substance]. Impact scores can also be obtained for damages on areas of protection if endpoint characterization factors are instead applied. DALY is an example of an endpoint impact category covering the area of protection human health, see further Section 2.1.1. The characterization factors are often based on environmental models, which model environmental mechanisms including fate, exposure and effects of substances, and are aimed at the provision of best estimates for impacts given limited knowledge (Hauschild, 2005). Some examples of life cycle impact assessment (LCIA) methods include ReCiPe (Goedkoop et al., 2013; Huijbregts et al., 2017), CML (Guinée et al., 2002) and IMPACT World+ (Bulle et al., 2019). It is furthermore possible to obtain a total score representing the total environmental and resource impact by weighting the impact assessment results based on economic values or other principles (Pizzol et al., 2017). In the *interpretation* step, the results are interpreted from the perspective of the study's goal and scope, conclusions are drawn, and sensitivity as well as uncertainty are assessed. Often, dominance and contribution analysis are conducted (Heijungs and Kleijn, 2001). Dominance analysis means the identification of life cycle processes that dominate various impact categories while a contribution analysis identifies the inputs and outputs that contribute the most to various impact categories.

Conventionally, LCA studies assess the environmental impacts associated with the product system. This type of LCA can be referred to as attributional, or accounting, LCA. Another type of LCA study is to assess consequences of an action or a decision, which is referred to as consequential, or change-oriented, LCA. Two main features of

consequential LCA is the use of marginal rather than average data for electricity and other input flows, as well as the use of substitution rather than allocation by mass or economic value when accounting for by-products (Ekvall and Weidema, 2004). The distinction between attributional and consequential LCA was suggested already by Tillman (2000) and the choice between these two types of LCA have emerged as the perhaps most discussed methodological topic in the LCA field, see e.g. Plevin et al. (2014) and Brandão et al. (2014). With consequential LCA being the more recent variant, there is still much room for methodological development of consequential LCA, in particular regarding which processes should be seen as affected by the decision and thus included in the product system (Zamagni et al., 2012). Recently, the idea that attributional and consequential LCA are actually not so different, but rather represent two sides of the same coin, has been put forward (Yang, 2016). For example, it is argued that consequential LCA can be conducted by considering different attributional LCAs as possible scenarios occurring due to a decision.

A more recent distinction is between conventional LCA, which considers products produced approximately at the time when the assessment is conducted, and a more future-oriented type of LCA called prospective or ex-ante (Arvidsson et al., 2018b; Cucurachi et al., 2018; Villares et al., 2017). In that type of LCA, a future state of product system is envisioned for a product still in an early stage of technological development, typically not commercialized yet. Commonly, predictive and/or explorative what-if scenarios reflecting different likely or possible futures are employed for assessing environmental and resource impacts at large-scale production and use. The purpose of prospective LCA is to conduct assessments of products at an early stage of technological development and commercialization, when there is more room for changes in the design at relatively modest efforts. In addition to social, attributional, consequential and prospective LCA, other variants of LCA also exist, see further Guinée et al. (2018).

2.1.1 Disability-adjusted life years (DALY)

The DALY indicator was applied as an endpoint indicator for the area of protection human health in Paper III and is therefore described in more detail in this section. DALY provides a measure for the number of years lost due to disability and/or premature death (Murray, 1994; Devleeschauwer et al., 2014):

$$\text{DALY} = \text{YLL} + \text{YLD} \quad \text{Eq. 2}$$

$$\text{YLL} = N \cdot L_{\text{death}} \quad \text{Eq. 3}$$

$$\text{YLD} = I \cdot D \cdot L \quad \text{Eq. 4}$$

where YLL is the years lost due to premature death [year], YLD is the years lost due to disability [year], N is the number of deaths [-], L_{death} is the standardized life time at the age of death and provides a measure of the number of years that the person could have lived but lost due to premature death [year], I is the number of incidents [-], D is the disability weight used to compare the time lived with a disability with years lost due to

premature death [-] and L is the average time spent with a disability until the severity of the disease is changed or the person dies [year]. DALY was developed for the World Health Organization and the World Bank in the 1990s (Murray and Lopez, 1996) and is commonly applied to quantify the burden of disease in a population such as in global burden of disease studies (Abajobir et al., 2017). The use of DALY in LCIA models include, for example, the older Ecoindicator99 method (Goedkoop and Spriensma, 2001) and more recently the ReCiPe method (Huijbregts et al., 2017). DALY can also be applied to assess occupational health impacts in LCA (Scanlon et al., 2015).

A number of social preferences are incorporated in DALY, which have consequences for the indicator's construction (Murray, 1994). These social preferences include: (i) the use of a standardized lifetime (L_{death}), (ii) age weighting, which implies that the time lived at different ages are valued differently, (iii) disability weighting (D) and (iv) discounting, implying the inclusion of time preferences. The incorporation of the social preferences of age weighting and discounting are eligible while the inclusion of a standard life expectancy and disability weighting are required in order to calculate DALY. Critique has been raised against the use of disability weighting, since this weighting is conducted independently from the social context, implying for example that no consideration is taken to the varying ability of people to handle the same disability (Anand and Hanson, 1998). For example, becoming disabled in a country with high-quality health care and services can be seen as less problematic than becoming disabled in a poor country with non-existing health care and services. Thus, methodological choices in the application of DALY need to be carefully considered and presented in a transparent manner.

2.2 Material flow analysis (MFA)

MFA is applied to study the societal metabolism, i.e. stocks and flows of materials and energy through the economy, from a systems perspective (Brunner and Rechberger, 2004). The societal metabolism can be compared with the movement of materials through the ecosystem, which constitutes a desirable metaphor for the former since the ecosystem has the capability of having a sustained development compared to many anthropogenic systems (Husar, 1994). The main difference between these systems are that anthropogenic systems lack efficient recyclers. Due to inefficient recycling or the lack of recycling, human-induced flows might lead to the accumulation of unwanted materials in the environment in turn causing pollution. The first material flow studies on resource conservation and environmental management appeared in the 1970s, examining the metabolism of cities and the pathways of pollutants in certain regions (Brunner and Rechberger, 2004). In 1996, the ConAccount network was established in order to provide a platform for exchanging information on MFA (Bringezu and Moriguchi, 2002). Today, the scope of materials being addressed using MFA include a wide range of materials, such as metals, fibers, construction materials, composite materials and water (Graedel, 2019). Material-flow related analysis with a focus on

specific substances, such as heavy metals and nutrients, is called substance flow analysis (SFA) (van der Voet, 2002). MFA and SFA are similar in many ways, and the latter can be considered a specific type of the former, but their applications differ. While MFA typically provides macroeconomic indicators for bulk flows, SFA is commonly used to provide information for chemical pollutant or scarce resource policies.

MFA is based on the principle of mass conservation (Lavoisier, 1789), which states that mass cannot be created nor destroyed but only transformed into other forms. The application of the principle of mass conservation makes MFA attractive as decision-support in environmental management since the results become possible to validate (Brunner and Rechberger, 2004). MFA is applied in diverse fields including resource conservation, environmental management, waste handling, product design and LCA (Brunner and Rechberger, 2004). The system boundaries applied in MFA studies can include certain materials or substances, industrial sectors and/or geographical areas (Bringezu and Moriguchi, 2002). The general procedure for MFA can be described by three steps: problem and scope formulation, flows and stocks quantification, and presentation and evaluation of results (Figure 4) (Brunner and Rechberger, 2004; Bringezu and Moriguchi, 2002; van der Voet, 2002). As Figure 4 indicates, these steps should be conducted iteratively.

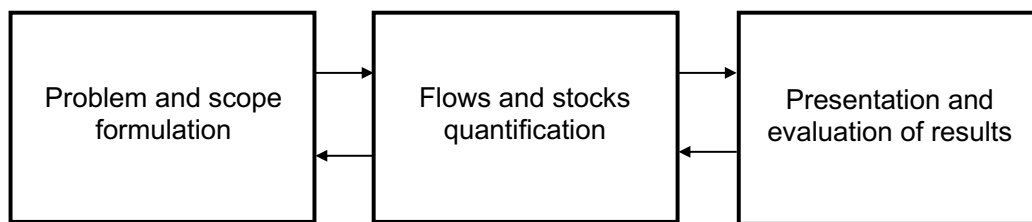

Figure 4. Steps in the general procedure for MFA (Brunner and Rechberger, 2004; Bringezu and Moriguchi, 2002; van der Voet, 2002)

In the *problem and scope formulation*, the study objectives and the study scope are defined. What materials, what flows and stocks to include in the study as well as the geographical and temporal boundaries are decided upon. The materials studied in MFA include goods, waste and chemical substances. In the *flows and stocks quantification* step, the principle of mass conservation is applied according to:

$$\sum_i m_i = \sum_o m_o + m_s \quad \text{Eq. 5}$$

where the sum of the mass (m_i) for all inputs i to a system equals the sum of the mass (m_o) for all outputs o from the system plus the stock (m_s). The stock is a reservoir of materials stored within the system, which can increase via accumulation of materials or decrease via depletion of materials in the system. Thus, the principle of mass

conservation is used to balance inputs and outputs of the studied system, and its processes, and it is applied to validate data as well as to quantify missing data. Static or dynamic modelling can be applied for the quantification depending on whether time variations in stocks are to be considered or not. In static modelling, the quantification is done by applying a steady state for flows and stocks while dynamic modelling considers the variations of stocks with time. The last step of *presentation and evaluation of results* involves an evaluation and presentation of the quantified flows and stocks together with, for example, MFA experts and stakeholders in policy- and decision-making processes. Results can be presented using for example Sankey diagrams, where arrows represent flows and the arrow's width typically indicate the quantity of the flows (Schmidt, 2008). In recent years, developments have been made, for example, to link MFA with environmental input-output assessment, scenario development and LCA in increasingly comprehensive assessments of future resource supply, demand as well as environmental impacts (Graedel, 2019).

3 RESULTS AND DISCUSSION

The methods applied in the appended papers and the main contributions of the appended papers are summarized in Table 2. The main findings are described in more detail in Section 3.1-3.3, which also provide the answers to the specific research questions outlined in Section 1.3. In addition, some reflections on data gathering are presented in Section 3.4.

Table 2. Overview of the papers included in this thesis

Paper	Method applied	Main contributions
I	LCA	LCI data and LCA results for non-Chinese WC-Co production
II	MFA	Dissipation and functional recycling rates of tungsten in the specific product of tire studs
III	LCA	Net health impacts of tire studs in a Scandinavian passenger car. A method for assessing negative human health impacts of conflict minerals
IV	LCA	LCI data and LCA results for synthetic diamond grit and PCD production. Comparison of WC-Co and PCD tools in two applications
V	Literature review	A framework for defining functional units in comparative LCAs of materials together with recommendations on its use

3.1 Environmental, resource and health impacts of WC-Co

Paper I, II and III show that WC-Co is marked by high environmental, resource and human health impacts. LCA results, as well as LCI data for non-Chinese WC-Co production, are provided in Paper I. A general flowchart for non-Chinese WC-Co production is presented in Figure 5. The paper presents a cradle-to-gate attributional LCA for the functional unit of 1 kg non-Chinese WC-Co with a typical cobalt content (6-16%) and tungsten carbide grain size ($>0.2 \mu\text{m}$). WC-Co properties, such as hardness and toughness, are affected by the cobalt content and tungsten carbide grain size. The system studied was divided into a foreground system, modelled mainly based on data from the technical literature on WC-Co, and a background system, modelled mainly based on generic data from the Ecoinvent database version 3.4 (2017). The foreground system included the phases of mining, hydrometallurgy and pyrometallurgy, which are responsible for the production of the WC-Co precursors of tungsten concentrates, ammonium paratungstate (APT) and tungsten carbide powder, respectively. It also included transport of scheelite and wolframite concentrates and the final step of WC-Co

production, called the powder metallurgy phase. The background system included the production of inputs and generation of energy to the foreground system as well as treatment of waste leaving the foreground system. Allocation by cut-off was applied for recycled products, meaning that only direct impacts associated with the recycled materials are attributed to the materials, thus they are “cut off” from the product system from which they are generated (Ekvall and Tillman, 1997). The impact assessment methods were selected based on recommendations for what impact categories to include in LCAs of metals (Santero and Hendry, 2016) and included climate change, terrestrial acidification, freshwater eutrophication, photochemical oxidant formation, ozone depletion and water depletion modeled by the ReCiPe method (version 2008) with the hierarchist scenario (Goedkoop et al., 2013), as well as primary energy requirement modeled by the cumulative energy demand (CED) indicator (Frischknecht et al., 2015) and waste generation modeled by the EDIP2003 method (Wenzel et al., 1998). Scenarios with varying recycling rates and types of tungsten ore (scheelite and wolframite) to assess model uncertainty, as well as baseline, low and a high environmental impact cases to assess parameter uncertainty, were constructed. The LCIA results together with a dominance and contribution analysis show that the mining, hydrometallurgy and powder metallurgy phases dominated most of the impact categories. A limited number of inputs and outputs, including e.g. diesel, tannin and sulfidic tailings in the mining phase, kerosene and electricity to hydrometallurgy, as well as cobalt and electricity to powder metallurgy, were the main contributors to the impact categories. A comparison of direct energy requirements to the foreground system furthermore shows that non-Chinese production of the tungsten carbide powder precursor (58 MJ eq/kg) is more energy-efficient than Chinese production (170 MJ eq/kg) as assessed by another study (Ma et al., 2017). The scenario analysis shows that increased recycling of tungsten greatly reduced the impacts, in particular for freshwater eutrophication (mainly due to avoided tailings from mining) and waste generation (mainly due to avoided mining waste). The LCI and LCIA results in Paper I can be subsequently used in cradle-to-grave LCAs of products including WC-Co or any of its precursors (as was the case in Paper IV – see Section 3.2 and 3.3).

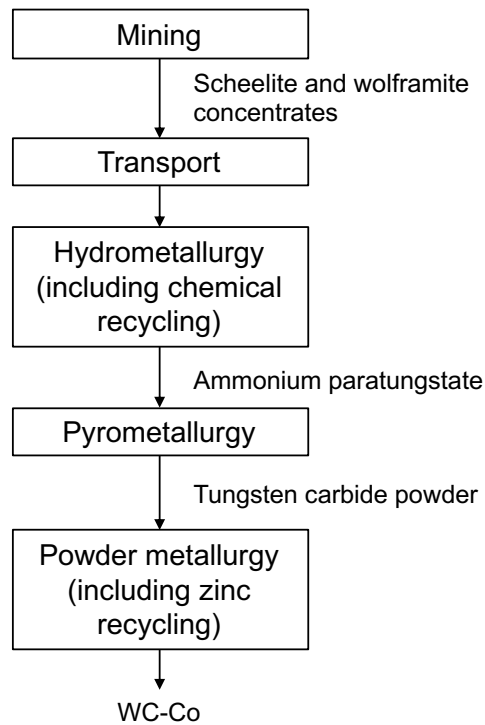

Figure 5. General flowchart for non-Chinese cemented carbide (WC-Co) production (based on Paper I)

Measures to reduce the dissipation of tungsten related to the use of the specific product tire studs with WC-Co pins (Figure 6) are presented in Paper II. Tire studs are used in passenger cars during winter in a number of countries, including Sweden, Norway, Finland, Canada, Russia and the United States (Tuononen and Sainio, 2014). Paper II assess resource implications by quantifying the dissipation and functional recycling rate of tungsten in tire studs (tungsten constitutes approximately 90 weight-% of the tire stud pins). Life cycle flows of tungsten related to the use of tire studs in Sweden were quantified using MFA and steady-state modelling. The results show that losses of tungsten during mining and in the use phase are substantial and that the dissipation from tire stud manufacturing to waste management was 100%, dominated by the use-phase release in the form of worn particles from the tire studs (accounting for 67% of these tungsten outflows). A sensitivity analysis was also conducted, showing that although the tungsten release and total tungsten input were sensitive to a number of input parameters, the dissipation rate was highly insensitive. Although almost all scrapped studded tires were shown to be collected in the waste management phase, 0% of the tungsten in tire studs were functionally recycled and landfilling was the dominating waste management approach for tire studs. The dissipation and functional recycling figures for tungsten in tire studs were compared to the global dissipation rate (>60%) (Zimmermann and Gößling-Reisemann, 2013) and the global functional recycling rate (10-25%) (Graedel et al., 2011) of tungsten, showing that the specific product of tire studs have much higher

dissipation and lower functional recycling. The use phase dissipation of tungsten was identified to be effectively unavoidable. However, measures for reducing dissipation were identified in the waste management of tire studs and include the development of methods for removing the tire studs before entering tire waste treatments as well as to separate tire studs from other waste fractions to enable tungsten recovery.

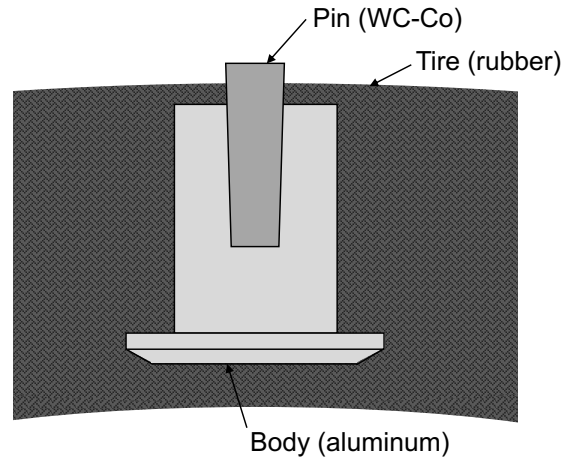

Figure 6. Schematic illustration of a tire stud with a cemented carbide (WC-Co) pin (from Paper II)

Net health impacts, including both positive and negative impacts, of the WC-Co containing product tire studs are presented in Paper III. Tire studs are applied to save lives by reducing the number of accidents, but their use is at the same time controversial and debated since it also causes an increased release of worn road particles in turn associated with negative human health impacts (Elvik et al., 2013). A cradle-to-grave LCA was conducted to study the net life cycle human health impacts of the use of tire studs in studded Scandinavian passenger cars. The DALY indicator and method for assessing human health impacts developed by Arvidsson et al. (2018a) was applied for this purpose:

$$DALY_X = \sum_p DALY_p - \sum_n DALY_n \quad \text{Eq. 6}$$

where p are positive health impacts and n are negative health impacts related to the product X . The functional unit was selected to be the number of tire studs in a studded passenger car, corresponding to 0.07-0.3 kg WC-Co and 0.31-0.65 kg aluminum in the tire stud pins and tire stud bodies, respectively (Figure 6). Three system boundaries were applied, focusing on (i) the use phase only, (ii) the product life cycle and (iii) a broader life cycle perspective including direct impacts related to the conflict financed by cobalt mining in the DRC. The health impacts included within the first system boundary were impacts saved in the use phase, e.g. based on accident reduction rates from using studded tires compared to other tires (Elvik, 1999), and negative impacts from use phase particle

emissions, e.g. based on emission factors (Ferm and Sjöberg, 2015). In the second system boundary, additional impacts from life cycle production emissions, e.g. for WC-Co from Paper I, and occupational accidents based on work environment characterization factors provided by Scanlon et al. (2015) and various data for occupational accidents in artisanal mining were included. The third system boundary included additional impacts caused by conflict-related causalities related to revenues in cobalt mining in the DRC. In order to be able to quantify these additional impacts, a method was developed by Furberg et al. (2018) and then applied in Paper III. The developed method provides per-kg results in terms of years lost due to direct premature deaths related to the extraction of conflict minerals in the DRC. This is achieved by distributing the deaths over the different conflict minerals i (applying the inclusive scenario used in Paper III, with all of tin, tantalum, tungsten, gold, copper, cobalt and diamond as conflict minerals) based on their economic value and the amount produced in the DRC during the time period j :

$$DALY_{ij} = \frac{N_j \cdot (LEX_j - L_j) \cdot P_{ij}}{\sum_i P_{ij} \cdot m_{ij}} \quad \text{Eq. 7}$$

where $DALY_{ij}$ is the number of years lost due to premature deaths related to the conflict in the DRC for the time period j and the conflict mineral i [years/kg], N is the number of premature direct deaths in the DRC due to the conflict [-], LEX is the national life expectancy [year], L is the average age at death [year], P is the average global market price [USD/kg] and m is the virgin production in the DRC [kg]. Cases of disability was not included due to limited data availability. Based on Furberg et al. (2018), the value applied in Paper III was $1.1 \cdot 10^{-4}$ and $3.2 \cdot 10^{-4}$ year/kg cobalt in the low and high impact scenarios, respectively.

The results from Paper III show that the use of tire studs in a studded passenger car is not justified from a life cycle perspective as the health benefits in the use phase are outweighed by the negative impacts during the life cycle. Use-phase particle emissions and occupational accidents during artisanal cobalt mining had the largest contribution to the negative human health impacts with 67–77% and 8–18%, respectively. A notable share of about 23–33% of the negative impacts occurs outside Scandinavia, where the benefits occur, implying a partly unfair distribution of health impacts along the life cycle of tire studs. A number of additional contributions to positive or negative human health impacts would have been interesting to include in this study, e.g. human health improvements from increased income in a population (Feschet et al., 2013), impacts from noise caused by studded tires (Johnsson and Nykänen, 2013) and indirect deaths associated with the conflict in the DRC (Checchi et al., 2017). The applicability of the method developed by Feschet et al. (2013) requires two conditions to be fulfilled: (i) the included processes should be located in poor countries and (ii) the wealth generated should become well spread over the countries' economic sectors. These requirements were not expected to be fulfilled in Paper III because most countries in the production system are not poor enough and wealth is not expected to become well spread over the

DRC's economic sectors due to corruption. In addition, the inclusion of the other aspects would only increase the negative human health impacts and thus only strengthen the conclusion from Paper III even more.

The resource impacts and net negative human health impacts of tire studs shown in Paper II and III indicate that assessments of alternatives to studded tires are required. Alternatives have been proposed, such as electronic stability control (Elvik, 2015), which is already applied in passenger cars to a large extent, and wear-resistant asphalt (Wen and Bhusal, 2014), but whether these alternatives provide the same function at lower net impacts remain for future studies to investigate. In addition, the alternative to shift to non-studded winter tires was raised in Paper II but it was also noted that these might not provide the same function in terms of accident reduction as studded ones do (Malmivuo et al., 2017). The results from Paper II and III on tire studs, highlighting the resource impacts and net negative human health impacts of this product, furthermore lead to the more basic question whether the use of certain materials, such as WC-Co, in specific applications perhaps should be avoided?

3.2 Environmental and resource impacts of PCD

In Paper IV, LCA results for industrial PCD production as well as for the production of diamond grit, which is a precursor to PCD consisting of a coarse powder, via HPHT synthesis are provided. Figure 7 illustrates a general flowchart for PCD production. A cradle-to-gate LCA is provided for the production of micron-sized diamond grit via HPHT synthesis with the functional unit of 1 g diamond grit. A comparative cradle-to-grave LCA for PCD and WC-Co tools in titanium alloys machining and wood working are also provided in Paper IV, see further Section 3.3. Impact categories were selected to represent both environmental as well as resource impacts and included climate change, terrestrial acidification, freshwater eutrophication, mineral resource scarcity (Huijbregts et al., 2017), cumulative energy demand (CED) (Frischknecht et al., 2015) and abiotic depletion with reserve base (Guinée et al., 2002; van Oers, 2016; van Oers and Guinée, 2016). Background system data was obtained from the Ecoinvent database version 3.5 (2018) and calculations were conducted applying the OpenLCA software (GreenDelta, 2019). Model uncertainties were assessed by the construction of a current scenario and three corner-stone scenarios, including the solar, full recycling and solar-full recycling scenarios, varying the WC-Co recycling rate and the type of electricity input to the foreground system. The scenarios thus reflect variations in impacts related to decisions that lie within the power of the foreground system actors, including diamond powder producers and tool makers. The LCIA results show that the main hotspot in diamond grit production via HPHT synthesis is the use of WC-Co in the high-pressure apparatus, which is required to obtain the high pressures and temperatures needed for the diamond formation. The process of producing the WC-Co required for the high-pressure apparatus dominated most impact categories, while the use of tungsten resources contributed the most to the impacts of mineral resource scarcity and abiotic

depletion with about 57-94% and 96-100%, respectively. Full recycling of WC-Co reduced the impacts with 23-91% compared to the current scenario depending on the impact category.

LCIA results for the PCD tool show that the largest contributor to climate change, for all scenarios, was the electricity required in PCD production. In terms of resource impacts, the largest contributors to mineral resource scarcity and abiotic depletion were tungsten and molybdenum. Main contributors to climate change for the WC-Co tool varied between the scenarios but included the input of electricity and tannin in WC-Co production, while the use of tungsten resources was the main contributor to mineral resource scarcity and abiotic depletion for the WC-Co tool. Increased recycling of WC-Co greatly reduces environmental and resource impacts of the WC-Co tool with 55-92% while the application of solar direct electricity greatly reduces the environmental impacts of the PCD tool with 31-65% compared with the current scenario.

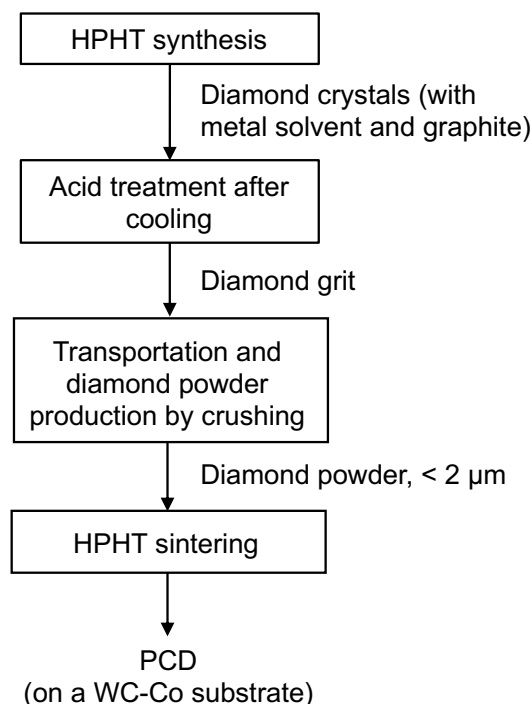

Figure 7. General flowchart for polycrystalline diamond (PCD) production (based on Paper IV). HPHT=high-pressure and high-temperature

3.3 Environmental and resource potential for substituting WC-Co with PCD

Paper IV and V provide a comparative LCA of WC-Co and PCD tools and a framework for defining functional units in comparative LCAs of materials, respectively. The comparative LCA of WC-Co and PCD tools in Paper IV was conducted for the specific applications of titanium alloys machining and wood working. The LCI data for the production of PCD and WC-Co tools in these specific applications were provided by collaborators as well as from the technical literature related to these materials and tools

made thereof. The comparison was based on performance data from collaborators for finishing operations in titanium alloys machining and fine-precision machining in wood working. The functional units applied were the surface area generated by one WC-Co tool during its lifetime in titanium alloys machining and the amount of workpiece material removed by one WC-Co tool during its lifetime in wood working. A break-even analysis was furthermore conducted to provide information on the in general required performance of one PCD tool in order to be environmentally and resource preferable compared to one WC-Co tool. The results show that there are both environmental and resource prospects for substituting WC-Co tools with PCD tools in the application of wood working. This was true for all included impact categories except for climate change, terrestrial acidification, freshwater eutrophication and CED in the full recycling scenario and climate change, terrestrial acidification and CED in the solar-full recycling scenario, which then was higher for PCD. This is since the impacts of WC-Co become greatly reduced in the full and solar-full recycling scenarios due to the 95% WC-Co recycling rate applied. In titanium alloys machining, the results show no environmental benefits, while the results for resource impacts are inconclusive. In the current and solar scenario, the resource impact category of mineral resource scarcity indicates that WC-Co is preferable while the abiotic depletion indicate that PCD is preferable. Thus, the results from Paper IV show that PCD can be preferable from a life cycle perspective compared to WC-Co in specific applications, both considering environmental and resource aspects. The results from the break-even analysis show that the environmental and resource targets to be reached by PCD in order to be beneficial in comparison to WC-Co in specific applications is >78 and >52 times the WC-Co tool's performance in the current and solar scenario, respectively. If PCD should constitute a preferable alternative to WC-Co in the full recycling and solar-full recycling, scenarios then it need a performance >570 and >380 times the WC-Co tool's performance, respectively. This is again since the WC-Co impacts are greatly reduced when a high WC-Co recycling rate is applied, reflecting the maximum technical recycling potential.

Paper IV shows that it is important to have a life cycle perspective in assessments of material substitution in order to avoid trade-offs between different types of impacts. The paper also shows that the scenarios constructed can affect the results to a large extent and this is important to have in mind in the development of scenarios as it relates to what the results represent as well as the message that is provided. Should the study represent the realistic, current state or a future desired state from an environmental and resource point of view? That should be carefully considered in the formulation of the study goal. In Paper IV, PCD is shown to be better than WC-Co in the specific application of wood working, however, PCD still contributes to resource depletion mainly through the use of WC-Co in the high-pressure apparatus required for PCD production. High-pressure apparatus parts can also be made out of synthetic diamond, which are applied for example in the fields of mineralogy and geophysics (Zhai and Ito, 2011). Including the

use of diamond anvils as a potential future scenario for PCD production would not describe the current situation but might still be relevant to consider as a future scenario.

A framework for defining functional units in comparative LCAs of materials was developed and is provided in Paper V. Based on a literature review, three different types of functional units are outlined: reference flow functional unit, material property functional unit and product performance functional unit (Table 3). The framework provides concrete recommendations on how to define functional units of different types by providing the characteristics of the functional unit types, including the method for functional unit construction and typical goals of different comparisons. Results from an illustration of the framework for the comparison between WC-Co and PCD hard materials show that the LCIA results largely depend on the type of functional unit that is selected. The degree of functional equivalence increases from the reference flow functional unit over the material property functional unit to the product performance functional unit, although complete functional equivalence can hardly be attained. The increased functional equivalence is accompanied by an increased data requirement and application-specificity, which in turn have implications for when the different functional unit types can be used. The reference flow functional unit could be used in screening assessments of materials within the same application areas. The material property type functional unit is recommended to be used in comparisons where it is known in more detail which material properties that are relevant in the foreseen applications and where there is a desire to conduct a somewhat generic comparison, not focusing on a specific product. When a certain product's function and application is known and well-defined, the product performance functional unit is recommended.

In comparative LCAs of materials, it is important to clarify what the functional unit represents since it constitutes the basis for the comparison. Still, the representation of the functional unit was unclear in some studies identified in the literature review in Paper V. The developed framework in Table 3 can aid in the clarification of what the functional unit represents by guiding the functional unit specification in a study and providing recommendations on when to apply the different functional unit types. Additional actions that can be made to clarify what it is that the material property or product performance functional unit type represents can be to split the information behind the functional unit into property and performance parameters, respectively.

Table 3. Parts of the framework for defining functional units in comparative LCAs of materials developed in Paper V. The upper part (description) of the framework specifies the functional unit types. The lower part (typical goal, data requirement and recommendations) shows some characteristics of studies applying these functional unit types as well as recommendations on the use of these types

<i>Aspect</i>	<i>Reference flow functional unit</i>	<i>Material property functional unit</i>	<i>Product performance functional unit</i>
<i>Description</i>	Represent a certain amount of materials with at least one common application area	Represent the main relevant properties of the material for certain applications	Represent the performance of the product in a specific application
<i>Typical goal</i>	Roughly compare the environmental impacts of materials in a broader application area	Compare the environmental impacts of materials based on some relevant properties	Compare the environmental impacts of materials in specific applications
<i>Data requirement*</i>	Low: requires data on material amounts	Medium: requires quantitative data about the material's main relevant properties	High: requires quantitative data related to the product's performance in the intended application
<i>Recommendations</i>	Use for screening comparisons of materials sharing an application area and be transparent about the lack of explicit property and performance considerations	Use for generic comparisons in applications where the main relevant properties are known and available	Use when a specific application is studied, and corresponding performance data is available

* Data requirement should here be interpreted from a fundamental perspective, not necessarily from an LCA analyst's perspective; product performance data might be easily available from information sources, but might have taken the sources years to obtain through multiple tests

3.4 Reflections on data gathering

Paper I and IV depended on an extensive gathering of data from various sources in order to construct the LCI data for WC-Co and PCD, respectively. A large amount of information is available from various sources, however, the information is not always publicly available and not always in the form suitable for LCA studies, why the work of gathering such data can be quite time-consuming. It is furthermore not always clear what the data represents, e.g. what processes are included, the scale of production, whether it represents conventional or specific procedures or whether the data is representative for one company or an entire industry. Thus, several sources typically need to be consulted and successful data gathering thus becomes a true craftsmanship. A lot of knowledge about the technology under study is required to be successful in the data gathering, which perhaps can be described as a process of encircling the proper type of information

one step at a time. Attending technical-oriented conferences can be helpful in this context by providing the possibility to discuss various aspects with researchers having a vast knowledge about the specific technology of interest. Graedel (2019) describes the character of a MFA specialist required in the sometimes difficult procedure of information gathering: “The MFA specialist must therefore be part detective, part archivist, part extractor of information from experts, and part bold estimator, in order to build the internally consistent database needed to achieve a useful material flow analysis.” This description is in good agreement with the experiences from data gathering and the creation of LCI data in Paper I and IV.

4 CONCLUSIONS AND RECOMMENDATIONS

The focus of this thesis is on material substitution and what materials that should be used in order to reduce environmental and resource impacts, applying the case of comparing WC-Co and PCD hard materials.

4.1 Environmental, resource and health impacts of WC-Co

The first aim of this thesis was to assess environmental, resource and human health impacts related to the currently dominating hard material WC-Co. Paper I-III show that the use of WC-Co is associated with environmental and resource as well as human health impacts. The main conclusions include:

- Environmental life cycle impact results of typical non-Chinese WC-Co production are dominated by a limited number of inputs and outputs (e.g. kerosene inputs, sulfidic tailings from tungsten mining and electricity use), as shown in Paper I
- All tungsten in the specific product of passenger car tire studs becomes dissipated and this dissipation is dominated by the effectively unavoidable use-phase particle release, as shown in Paper II
- The purpose of tire studs in a studded Scandinavian passenger car to prevent injuries is not justified since the negative human health impacts outweigh the positive health impacts, as shown in Paper III
- The developed framework applied in Paper III enables the inclusion of negative impacts associated with conflict minerals in assessments of human health impacts

4.2 Environmental and resource impacts of PCD

The second aim was to assess environmental and resource impacts related to the novel, and largely carbon-based hard material, PCD. The main conclusions include:

- LCA results for PCD production show that the electricity required in PCD production contribute greatly to the environmental impacts, while the use of tungsten and molybdenum largely contribute to resource impacts, as shown in Paper IV
- The application of solar direct electricity in PCD production can greatly reduce the environmental impacts with 31-65% compared to the current scenario, as shown in Paper IV

4.3 Environmental and resource potential for substituting WC-Co with PCD

The third aim was to assess the environmental and resource potential for substituting WC-Co with PCD. The main conclusions include:

- The comparison of WC-Co and PCD tools in the specific applications of wood working and titanium alloys machining in Paper IV shows that PCD can be

preferable to WC-Co in the application of wood working both in terms of environmental and resource impacts

- Applying the developed framework for defining functional units in comparative LCAs in Paper V to the case of hard materials shows that the functional unit applied clearly affect the impact results and the outcome of such comparisons

4.4 The importance of a life cycle perspective in material substitution

Some appraisals of material substitution arguably adapt a limited perspective. For example, some studies tend to focus mainly on price and performance while environmental and resource issues are not considered. The report by European Commission (2017), on critical materials for the EU, stated that the replaceability of tungsten is low in the majority of cases since it offers an excellent compromise between performance and price while tungsten's potential substitutes come with lower performance and/or higher price. Some suggested substitutes for WC-Co, or its tungsten carbide part, include molybdenum carbides, tantalum carbides and silicon in ceramic-metallic composites as well as diamond and cubic boron-nitride (European Commission, 2017; Prakash, 2014). If the purpose is to reduce society's resource impacts and dependence on scarce metals, however, the focus on price and performance is inadequate. This is especially since some of these suggested substitutes, including molybdenum and tantalum, are similar in terms of geochemical scarcity as tungsten (Wedepohl, 1995). In addition, the potential of PCD in several important cemented carbide applications (Konstanty, 2014b; Konstanty, 2005) does not seem to have been given a high credibility.

A more logical approach for reducing society's resource impacts would be to substitute a scarce material with a less scarce material. However, materials can also be indirectly related to the use of scarce materials upstream in their production system. For example, scarce elements might be required for the production of materials. In the case of comparing PCD and WC-Co, PCD might at a first glance seem clearly advantageous to WC-Co from a resource perspective, since it is largely carbon-based with about 90 weight-% carbon. WC-Co, on the other hand, mainly consists of the scarce materials tungsten and cobalt. However, as shown in Paper IV, the current production system of PCD is quite dependent on WC-Co for the high-pressure apparatus parts. Furthermore, the PCD tool tips, assessed in Paper IV, are placed onto WC-Co substrates. This illustrates that from a life cycle perspective, PCD is not independent of scarce materials. It is thus not only the content of the studied material itself that matters but also the use of scarce materials elsewhere in the life cycle. Such resource impact contributions are also important to consider in assessments of material substitution. This is illustrated by the results in Paper IV as the resource potential to substitute WC-Co with PCD was inconclusive for titanium alloys machining.

Other studies are limited by only considering certain life cycle processes, such as the studies by Mendoza et al. (2014) and Aurich et al. (2013). They suggest that diamond tools constitute a more environmentally sustainable alternative compared to conventional tool materials based on the longer lifetimes and improved machining performances of diamond tools. Although such studies can provide early indications, they are limited since the potential risk of trade-offs between impacts when substituting one material for another is overlooked. Although the PCD tool is less dependent on tungsten, it requires large amounts of electricity for its production that could cause a trade-off between resource and environmental impacts, which was the case for the application of titanium alloys machining and wood working in the full recycling and solar-full recycling scenarios in Paper IV. In summary, this thesis shows that a life-cycle perspective is required in order to avoid a situation where material substitution results in “going out of the ashes and into the fire” and the application of a life-cycle perspective in assessments of material substitution is therefore highly recommended.

4.5 Early assessments of material substitution

One way to inform the transition towards a more sustainable use of resources could be to conduct early assessments of material substitution to abundant materials through the adoption of emerging technologies. This might pave the way for less incremental solutions for the reduction of resource impacts, such as the use of tantalum carbide instead of tungsten carbide discussed in Section 4.4. Early LCAs of novel materials in emerging technologies could apply either the reference flow or material property functional units described in Paper V. The functional unit type applied depends on the data availability and application-specificity. The requirements of the reference flow functional unit in terms of data availability and the existence of a specific application is lower compared with the material property functional unit, which in turn has lower requirements than the product performance functional unit. At the same time, applying the two former functional unit types comes at the cost of a lower degree of functional equivalence, and thus a lower relevance, compared to applying the product performance functional unit, for which the data demand is high, and a specific application must have been identified. Early LCAs of material substitution might require somewhat different methodology, as provided by prospective, or ex-ante, LCA (Arvidsson et al., 2018b; Villares et al., 2017; Cucurachi et al., 2018) due to the emerging nature of the novel material technologies.

Some examples of other carbon-based novel hard materials that could be studied in such early assessments include various diamond types produced via chemical vapor deposition (CVD) and detonation nanodiamond (NDN) synthesis (Kumar et al., 2019; Palyanov et al., 2015). The resulting diamond materials produced from these processes include, for example, diamond films and nanodiamond, which have emerging production routes that have been extensively developed in recent years and continue to develop (Kumar et al., 2019; Palyanov et al., 2015). They also have several potential applications

as hard materials, including cutting, drilling and polishing, as well as other types of applications (Kumar et al., 2019; Schwander and Partes, 2011). For example, Kumar et al. (2019) stated that nanodiamonds might be used in energy storage devices, photovoltaic devices and water treatment. Thus, novel hard materials, as well as materials promising for other applications, which might substitute scarcer materials, are continuously being developed. It is recommended to conduct early assessments of such novel materials in order to investigate their potential to reduce environmental and resource impacts of various applications.

4.6 Material substitution and social aspects

Social aspects, such as human health impacts, are also important to consider in assessments of hard materials. Paper III shows that assessments of human health can sometimes lead to the questioning of the very purpose of certain materials in specific products. In addition to the various negative human health impacts assessed in Paper III, positive impacts associated with the fact the mining of cobalt generate an income to artisanal DRC miners could potentially be expected. Currently, however, the available methods to include positive human health impacts associated with increased income, such as the Preston pathway (Feschet et al., 2013), are not applicable to artisanal mining in the DRC (see furthermore Section 3.1). This method is limited to poor countries where the generated wealth become spread over the countries' economic sectors (Feschet et al., 2013). However, this is probably not the case in the DRC due to high corruption – it was ranked as 161 out of 180 countries in the corruption perception index in 2017 (Transparency International, 2019). At the same time, there are studies, such as the one by Sovacool (2019), indicating that although artisanal cobalt mining in the DRC is associated with negative health impacts related to for example occupational accidents and violent conflicts, artisanal mining can also offer an economic lifeline out of poverty for the miners, evidently despite the prevailing corruption. Thus, artisanal mining can in addition to negative health impacts potentially be accompanied with positive health impacts for artisanal miners from having an income. There is therefore a need to develop a new approach or method for assessing this positive contribution to human health impacts. Such method development for social aspects in general is currently ongoing in the field of social LCA, see for example Di Cesare et al. (2018).

An interesting case to apply for the illustration of such a developed approach or method would be the comparison between natural and synthetic diamond in jewelry. Today, about one tenth of the global natural diamond production comes from artisanal mining in the DRC (USGS, 2018b) and artisanal mining is commonly associated with other social aspects as well, such as child labor (Sovacool, 2019). Synthetic diamond is potentially free from that type of impacts, but might involve other negative social impacts, such as health impacts from energy use-related emissions during production. The development of methods for considering positive human health and other social

impacts of hard materials, for example associated with an increased income for artisanal miners, is thus recommended.

5 REFERENCES

- Abajobir AA, Abate KH, Abbafati C, et al. (2017) Global, regional, and national disability-adjusted life-years (DALYs) for 333 diseases and injuries and healthy life expectancy (HALE) for 195 countries and territories, 1990–2016: a systematic analysis for the Global Burden of Disease Study 2016. *The Lancet* 390(10100): 1260-1344.
- Anand S and Hanson K (1998) DALYs: efficiency versus equity. *World Development* 26(2): 307-310.
- Arvidsson R, Hildenbrand J, Baumann H, et al. (2018a) A method for human health impact assessment in social LCA: lessons from three case studies. *International Journal of Life Cycle Assessment* 23(3): 690-699.
- Arvidsson R and Sandén BA (2017) Carbon nanomaterials as potential substitutes for scarce metals. *Journal of Cleaner Production* 156: 253-261.
- Arvidsson R, Tillman AM, Sandén BA, et al. (2018b) Environmental Assessment of Emerging Technologies: Recommendations for Prospective LCA. *Journal of Industrial Ecology* 22(6): 1286-1294.
- Aurich JC, Linke B, Hauschild M, et al. (2013) Sustainability of abrasive processes. *CIRP Annals - Manufacturing Technology* 62(2): 653-672.
- Ayres RU and Ayres LW (2002) *A Handbook of Industrial Ecology*. Cheltenham, UK: Edward Elgar.
- Baumann H, Arvidsson R, Tong H, et al. (2013) Does the production of an airbag injure more people than the airbag saves in traffic?: Opting for an empirically based approach to social life cycle assessment. *Journal of Industrial Ecology* 17(4): 517-527.
- Baumann H and Tillman A-M (2004) *The Hitchhiker's Guide to LCA: An Orientation in Life Cycle Assessment Methodology and Application*. Lund, Sweden: Studentlitteratur.
- Bobba S, Deorsola FA, Blengini GA, et al. (2016) LCA of tungsten disulphide (WS₂) nano-particles synthesis: state of art and from-cradle-to-gate LCA. *Journal of Cleaner Production* 139: 1478-1484.
- Bobzin K (2017) High-performance coatings for cutting tools. *CIRP Journal of Manufacturing Science and Technology* 18: 1-9.
- Brandão M, Clift R, Cowie A, et al. (2014) The Use of Life Cycle Assessment in the Support of Robust (Climate) Policy Making: Comment on “Using Attributional Life Cycle Assessment to Estimate Climate-Change Mitigation ...”. *Journal of Industrial Ecology* 18(3): 461-463.
- Bringezu S and Moriguchi Y (2002) Material flow analysis. In: Ayres RU and Ayres LW (eds) *A Handbook of Industrial Ecology*. Cheltenham, U.K: Edward Elgar, pp.79-90.
- Brunner PH and Rechberger H (2004) *Practical Handbook of Material Flow Analysis*. Boca Raton, U.S: Lewis Publishers.

- Bulle C, Margni M, Patouillard L, et al. (2019) IMPACT World+: a globally regionalized life cycle impact assessment method. *International Journal of Life Cycle Assessment* 24(9): 1653-1674.
- Checchi F, Warsame A, Treacy-Wong V, et al. (2017) Public health information in crisis-affected populations: a review of methods and their use for advocacy and action. *The Lancet* 390(10109): 2297-2313.
- Consoli F, Allen D, Boustead I, et al. (1993) *Guidelines for Life-Cycle Assessment: A Code of Practice*. Brussels: Society of Environmental Toxicology and Chemistry (SETAC).
- Cooper JS (2003) Specifying Functional Units and Reference Flows for Comparable Alternatives. *International Journal of Life Cycle Assessment* 8(6): 337-349.
- Cucurachi S, Van Der Giesen C and Guinée J (2018) Ex-ante LCA of Emerging Technologies. *Procedia CIRP* 69: 463-468.
- De Bruyn S (2002) Dematerialization and rematerialization as two recurring phenomena of industrial ecology. In: Ayers RU and Ayers LW (eds) *A Handbook of Industrial Ecology*. Cheltenham: Edward Elgar, pp.209-222.
- Devleeschauwer B, Havelaar A, Maertens de Noordhout C, et al. (2014) DALY calculation in practice: a stepwise approach. *International Journal of Public Health* 59(3): 571-574.
- Di Cesare S, Silveri F, Sala S, et al. (2018) Positive impacts in social life cycle assessment: state of the art and the way forward. *International Journal of Life Cycle Assessment* 23(3): 406-421.
- Ecoinvent database version 3.4 (2017). <http://www.ecoinvent.org> (2017-11-10).
- Ecoinvent database version 3.5 (2018). <http://www.ecoinvent.org> (2019-05-20).
- Ekvall T and Tillman A-M (1997) Open-loop recycling: Criteria for allocation procedures. *International Journal of Life Cycle Assessment* 2(3): 155.
- Ekvall T and Weidema BP (2004) System boundaries and input data in consequential life cycle inventory analysis. *The International Journal of Life Cycle Assessment* 9(3): 161-171.
- Elenge M, Leveque A and De Brouwer C (2013) Occupational accidents in artisanal mining in Katanga, D.R.C. *International Journal of Occupational Medicine and Environmental Health* 26(2): 265-274.
- Elvik R (1999) The effects on accidents of studded tires and laws banning their use: a meta-analysis of evaluation studies. *Accident Analysis and Prevention* 31(1): 125-134.
- Elvik R (2015) Can electronic stability control replace studded tyres? *Accident Analysis and Prevention* 85: 170-176.
- Elvik R, Fridstrøm L, Kaminska J, et al. (2013) Effects on accidents of changes in the use of studded tyres in major cities in Norway: A long-term investigation. *Accident Analysis and Prevention* 54: 15-25.
- Ettmayer P, Kolaska H and Ortner HM (2014) History of Hardmetals. In: Sarin VK, Mari D and Llanes L (eds) *Comprehensive Hard Materials*. Oxford, U.K: Elsevier, pp.3-27.

- European Commission (2010) International Reference Life Cycle Data System (ILCD) Handbook - General guide for Life Cycle Assessment - Detailed guidance. First edition March 2010. Luxembourg: Publications Office of the European Union.
- European Commission (2017) Study on the review of the list of Critical Raw Materials. Critical Raw Materials Factsheets. June 2017. Luxembourg: Publications Office of the European Union.
- Fang ZZ, Koopman MC and Wang H (2014) Cemented Tungsten Carbide Hardmetal - An Introduction. In: Sarin VK, Mari D and Llanes L (eds) *Comprehensive Hard Materials*. Oxford, U.K: Elsevier, pp.123-137.
- Ferm M and Sjöberg K (2015) Concentrations and emission factors for PM_{2.5} and PM₁₀ from road traffic in Sweden. *Atmospheric Environment* 119: 211-219.
- Ferreira V, Egizabal P, Popov V, et al. (2019) Lightweight automotive components based on nanodiamond-reinforced aluminium alloy: A technical and environmental evaluation. *Diamond and Related Materials* 92: 174-186.
- Feschet P, MacOmbe C, Garrabé M, et al. (2013) Social impact assessment in LCA using the Preston pathway: The case of banana industry in Cameroon. *International Journal of Life Cycle Assessment* 18(2): 490-503.
- Finnveden G, Hauschild MZ, Ekvall T, et al. (2009) Recent developments in Life Cycle Assessment. *Journal of Environmental Management* 91(1): 1-21.
- Finnveden G and Moberg Å (2005) Environmental systems analysis tools – an overview. *Journal of Cleaner Production* 13(12): 1165-1173.
- Frischknecht R, Wyss F, Büsser Knöpfel S, et al. (2015) Cumulative energy demand in LCA: the energy harvested approach. *International Journal of Life Cycle Assessment* 20(7): 957-969.
- Furberg A, Arvidsson R and Molander S (2018) Using DALY for Assessing Human Health Impacts of Conflict Minerals. *S-LCA conference*. Pescara, Italy.
- Gilbertson LM, Busnaina AA, Isaacs JA, et al. (2014) Life cycle impacts and benefits of a carbon nanotube-enabled chemical gas sensor. *Environmental Science & Technology* 48(19): 11360-11368.
- Goedkoop M, Heijungs R, Huijbregts M, et al. (2013) ReCiPe 2008. A life cycle impact assessment method which comprises harmonised category indicators at the midpoint and endpoint level. First edition (version 1.08). Report I: Characterisation. The Hague: Dutch Ministry of Housing, Spatial Planning and Environment (VROM).
- Goedkoop M and Spriensma R (2001) The Eco-indicator 99. A damage oriented method for Life Cycle Impact Assessment. Methodology Annex. Third edition. PRé consultants Amersfoort.
- Graedel TE (2019) Material Flow Analysis from Origin to Evolution. *Environmental Science & Technology* 53(21): 12188-12196.
- Graedel TE, Allwood J, Birat JP, et al. (2011) What do we know about metal recycling rates? *Journal of Industrial Ecology* 15(3): 355-366.

- Graedel TE, Harper EM, Nassar NT, et al. (2015) On the materials basis of modern society. *Proceedings of the National Academy of Sciences of the United States of America* 112(20): 6295-6300.
- GreenDelta (2019) OpenLCA software version 1.8. Released February, 2019.
- Guinée JB, Cucurachi S, Henriksson PJG, et al. (2018) Digesting the alphabet soup of LCA. *International Journal of Life Cycle Assessment* 23(7): 1507-1511.
- Guinée JB, Gorrée M, Heijungs R, et al. (2002) *Handbook on life cycle assessment. Operational guide to the ISO standards. I: LCA in perspective. Iia: Guide. Iib: Operational annex. III: Scientific background.* Dordrecht: Kluwer Academic Publishers.
- Guinée JB, Heijungs R and Huppes G (2004) Economic allocation: Examples and derived decision tree. *The International Journal of Life Cycle Assessment* 9(1): 23.
- Guinée JB, Heijungs R, Huppes G, et al. (2011) Life cycle assessment: Past, present, and future. *Environmental Science & Technology* 45(1): 90-96.
- Guinée JB, Van Den Bergh JCJM, Boelens J, et al. (1999) Evaluation of risks of metal flows and accumulation in economy and environment. *Ecological Economics* 30(1): 47-65.
- Harper EM and Graedel TE (2008) Illuminating tungsten's life cycle in the United States: 1975-2000. *Environmental Science & Technology* 42(10): 3835-3842.
- Hauschild MZ (2005) Assessing environmental impacts in a life-cycle perspective. *Environmental Science & Technology* 39(4): 81A-88A.
- Hauschild MZ and Huijbregts MAJ (2015) *LCA Compendium - The Complete World of Life Cycle Assessment. Life Cycle Impact Assessment.* Dordrecht: Springer.
- Heijungs R and Kleijn R (2001) Numerical approaches towards life cycle interpretation five examples. *International Journal of Life Cycle Assessment* 6(3): 141-148.
- Hellweg S and Milà i Canals L (2014) Emerging approaches, challenges and opportunities in life cycle assessment. *Science* 344(6188): 1109.
- Hetherington AC, Borrión AL, Griffiths OG, et al. (2014) Use of LCA as a development tool within early research: Challenges and issues across different sectors. *International Journal of Life Cycle Assessment* 19(1): 130-143.
- Huijbregts MAJ, Steinmann ZJN, Elshout PMF, et al. (2017) ReCiPe2016: a harmonised life cycle impact assessment method at midpoint and endpoint level. *International Journal of Life Cycle Assessment* 22(2): 138-147.
- Hummel RE (2004) *Understanding Materials Science: History, Properties and Applications. Second edition.* New York: Springer.
- Husar RB (1994) Ecosystem and the biosphere: Metaphors for human-induced material flows. In: Ayres RU and Simonis UE (eds) *Industrial Metabolism – Restructuring for Sustainable Development.* Tokyo: United Nations University Press, pp.21-30.
- ILO (1999) (International Labour Organization) *Social and labour issues in small-scale mines.* Geneva; OIT.

- ISO (2006) Environmental Management - Life Cycle Assessment - Principles and Framework. International Organization for Standardization, Geneva, Switzerland.
- Johnsson R and Nykänen A (2013) Stud Noise Auralization. *SAE International Journal of Passenger Cars - Mechanical Systems* 6(3): 1577-1585.
- Kasu M (2016) Diamond epitaxy: Basics and applications. *Progress in Crystal Growth and Characterization of Materials* 62(2): 317-328.
- Kesler SE and Simon AC (2015) *Mineral Resources, Economics and the Environment*. Cambridge, United Kingdom.: Cambridge University Press.
- Kirchherr J, Reike D and Hekkert M (2017) Conceptualizing the circular economy: An analysis of 114 definitions. *Resources, Conservation and Recycling* 127: 221-232.
- Kobayashi Y, Peters GM, Ashbolt NJ, et al. (2017) Aggregating local, regional and global burden of disease impact assessment: detecting potential problem shifting in air quality policy making. *International Journal of Life Cycle Assessment* 22(10): 1543-1557.
- Konstanty J (2005) *Powder Metallurgy Diamond Tools*. Amsterdam: Elsevier Science.
- Konstanty J (2014a) Applications of powder metallurgy to cutting tools. In: Chang I and Zhao Y (eds) *Advances in powder metallurgy - properties, processing and applications*. Woodhead Publishing.
- Konstanty J (2014b) Applications of powder metallurgy to cutting tools. In: Chang I and Zhao Y (eds) *Advances in powder metallurgy - properties, processing and applications*. Woodhead Publishing, pp.555-585.
- Kumar S, Nehra M, Kedia D, et al. (2019) Nanodiamonds: Emerging face of future nanotechnology. *Carbon* 143: 678-699.
- Labys WC (2002) Transmaterialization. In: Ayers RU and Ayers LW (eds) *A Handbook of Industrial Ecology*. Cheltenham: Edward Elgar, pp.202-208.
- Lavoisier A (1789) *Traité élémentaire de chimie, présenté dans un ordre nouveau et d'après les découvertes modernes*. Paris: Chez Cuchet.
- Leal-Ayala DR, Allwood JM, Petavratzi E, et al. (2015) Mapping the global flow of tungsten to identify key material efficiency and supply security opportunities. *Resources, Conservation and Recycling* 103: 19-28.
- Löfstedt R (2014) The substitution principle in chemical regulation: A constructive critique. *Journal of Risk Research* 17(5): 543-564.
- Lowther JE (2014) From Diamond to Superhard Borides and Oxides. In: Sarin VK, Mari D and Llanes L (eds) *Comprehensive Hard Materials*. Oxford, U.K: Elsevier, pp.3-27.
- Lubchenco J (1998) Entering the century of the environment: A new social contract for science. *Science* 279(5350): 491-497.
- Ma X, Qi C, Ye L, et al. (2017) Life cycle assessment of tungsten carbide powder production: A case study in China. *Journal of Cleaner Production* 149: 936-944.
- Malmivuo M, Luoma J and Porthin M (2017) Studded and unstudded winter tires in fatal road accidents in Finland. *Traffic Injury Prevention* 18(5): 550-555.

- Mendoza JMF, Capitano C, Peri G, et al. (2014) Environmental management of granite slab production from an industrial ecology standpoint. *Journal of Cleaner Production* 84(1): 619-628.
- Murray CJL (1994) Quantifying the burden of disease: The technical basis for disability-adjusted life years. *Bulletin of the World Health Organization* 72(3): 429-445.
- Murray CJL and Lopez AD (1996) *The global burden of disease: A comprehensive assessment of mortality and disability from diseases, injuries and risk factors in 1990 and projected to 2020*. Cambridge: Harvard University Press.
- Ness B, Urbel-Piirsalu E, Anderberg S, et al. (2007) Categorising tools for sustainability assessment. *Ecological Economics* 60(3): 498-508.
- Palyanov YN, Kupriyanov IN, Khokhryakov AF, et al. (2015) Crystal Growth of Diamond. In: Rudolph P (ed) *Handbook of Crystal Growth (Second Edition)*. Boston: Elsevier, pp.671-713.
- Pizzol M, Laurent A, Sala S, et al. (2017) Normalisation and weighting in life cycle assessment: quo vadis? *22(6)*: 853-866.
- Plevin RJ, Delucchi MA and Creutzig F (2014) Using Attributional Life Cycle Assessment to Estimate Climate-Change Mitigation Benefits Misleads Policy Makers. *Journal of Industrial Ecology* 18(1): 73-83.
- Prakash L (2014) Fundamentals and General Applications of Hardmetals. In: Sarin VK, Mari D and Llanes L (eds) *Comprehensive Hard Materials*. Oxford: Elsevier, pp.29-90.
- Reap J, Roman F, Duncan S, et al. (2008) A survey of unresolved problems in life cycle assessment. Part 1: Goal and scope and inventory analysis. *International Journal of Life Cycle Assessment* 13(4): 290-300.
- Santero N and Hendry J (2016) Harmonization of LCA methodologies for the metal and mining industry. *International Journal of Life Cycle Assessment* 21(11): 1543-1553.
- Sarin VK (2014) *Comprehensive Hard Materials*, volume I-III. Oxford, U.K: Elsevier.
- Scanlon KA, Lloyd SM, Gray GM, et al. (2015) An Approach to Integrating Occupational Safety and Health into Life Cycle Assessment: Development and Application of Work Environment Characterization Factors. *Journal of Industrial Ecology* 19(1): 27-37.
- Schmidt M (2008) The Sankey Diagram in Energy and Material Flow Management. *Journal of Industrial Ecology* 12(2): 173-185.
- Schwander M and Partes K (2011) A review of diamond synthesis by CVD processes. *Diamond and Related Materials* 20(9): 1287-1301.
- Sovacool BK (2019) The precarious political economy of cobalt: Balancing prosperity, poverty, and brutality in artisanal and industrial mining in the Democratic Republic of the Congo. *The Extractive Industries and Society* 6(3): 915-939.
- Suh S and Huppes G (2005) Methods for life cycle inventory of a product. *Journal of Cleaner Production* 13(7): 687-697.

- Syrrakou E, Papaefthimiou S and Yianoulis P (2005) Environmental assessment of electrochromic glazing production. *Solar Energy Materials & Solar Cells* 85(2): 205-240.
- Tillman AM (2000) Significance of decision-making for LCA methodology. *Environmental Impact Assessment Review* 20(1): 113-123.
- Transparency International (2019) *Corruptions perceptions index 2017*. Available at: https://www.transparency.org/news/feature/corruption_perceptions_index_2017 (2019-12-05).
- Tuononen AJ and Sainio P (2014) Optimal proportion of studded tyres in traffic flow to prevent polishing of an icy road. *Accident Analysis and Prevention* 65: 53-62.
- USGS (2017) (United States Geological Survey) 2015 Minerals Yearbook Cobalt [Advanced release]. September, 2017.
- USGS (2018a) (United States Geological Survey) 2015 Minerals Yearbook Tungsten [Advanced release]. January 2018.
- USGS (2018b) (United States Geological Survey) Minerals yearbook, Diamond, Industrial 2015, May 2018.
- Vadenbo C, Hellweg S and Astrup TF (2017) Let's Be Clear(er) about Substitution: A Reporting Framework to Account for Product Displacement in Life Cycle Assessment. *Journal of Industrial Ecology* 21(5): 1078-1089.
- van der Voet E (2002) Substance flow analysis methodology. In: Ayres R and Ayres LW (eds) *A Handbook of Industrial Ecology*. Cheltenham: Edward Elgar, pp.91-101.
- Van Der Voet E, Van Oers L and Nikolic I (2005) Dematerialization: Not just a matter of weight. *Journal of Industrial Ecology* 8(4): 121-137.
- van Leeuwen CJ and Vermiere TG (2007) *Risk Assessment of Chemicals: An Introduction*. 2nd edition. Dordrecht: Springer.
- van Oers L (2016) *CML-IA database, characterisation and normalisation factors for midpoint impact category indicators. Version 4.8, August 2016*. Available at: <https://www.universiteitleiden.nl/en/research/research-output/science/cml-ia-characterisation-factors> (2019-08-20).
- van Oers L and Guinée J (2016) The abiotic depletion potential: Background, updates, and future. *Resources* 5(1): 16-27.
- Villares M, Işıldar A, van der Giesen C, et al. (2017) Does ex ante application enhance the usefulness of LCA? A case study on an emerging technology for metal recovery from e-waste. *International Journal of Life Cycle Assessment* 22(10): 1618-1633.
- Wang P, Li W and Kara S (2018) Dynamic life cycle quantification of metallic elements and their circularity, efficiency, and leakages. *Journal of Cleaner Production* 174: 1492-1502.
- Wedepohl KH (1995) The composition of the continental crust. *Geochimica et Cosmochimica Acta* 59(7): 1217-1232.
- Wen H and Bhusal S (2014) Toward development of asphaltic materials to resist studded tire wear. *Transportation Research Record* 2446: 78-88.

- Wenzel H, Hauschild M and Alting L (1998) *Environmental assessment of products. Volume 2: Scientific background*. London: Chapman & Hall.
- Wigger H, Steinfeldt M and Bianchin A (2017) Environmental benefits of coatings based on nano-tungsten-carbide cobalt ceramics. *Journal of Cleaner Production* 148: 212-222.
- Wilfong C, Gomez H and Durham D (2012) Life cycle analysis of diamond coating of machining tools. *ASME 2012 International Manufacturing Science and Engineering Conference Collocated with the 40th North American Manufacturing Research Conference and in Participation with the Int. Conf., MSEC 2012*. 1049-1056.
- Wolfe TA, Jewett TJ and Singh Gaur RP (2014) Powder Synthesis. In: Sarin VK, Mari D and Llanes L (eds) *Comprehensive Hard Materials*. Oxford, U.K: Elsevier, pp.185-212.
- Xiong Y, Lau K, Zhou X, et al. (2008) A streamlined life cycle assessment on the fabrication of WC-Co cermets. *Journal of Cleaner Production* 16(10): 1118-1126.
- Yang Y (2016) Two sides of the same coin: consequential life cycle assessment based on the attributional framework. *Journal of Cleaner Production* 127: 274-281.
- Young SB (2018) Responsible sourcing of metals: certification approaches for conflict minerals and conflict-free metals. *International Journal of Life Cycle Assessment* 23(7): 1429-1447.
- Zamagni A, Guinée J, Heijungs R, et al. (2012) Lights and shadows in consequential LCA. *The International Journal of Life Cycle Assessment* 17(7): 904-918.
- Zhai S and Ito E (2011) Recent advances of high-pressure generation in a multianvil apparatus using sintered diamond anvils. *Geoscience Frontiers* 2(1): 101-106.
- Zimmermann T (2015) *Cycles of Critical Metals: Dissipative Losses and Potential Optimizations*. Ph.D., Thesis, University of Bremen.
- Zimmermann T (2017) Uncovering the Fate of Critical Metals: Tracking Dissipative Losses along the Product Life Cycle. *Journal of Industrial Ecology* 21(5): 1198-1211.
- Zimmermann T and Gößling-Reisemann S (2013) Critical materials and dissipative losses: A screening study. *Science of the Total Environment* 461-462: 774-780.