



## **Numerical Simulations and Empirical Data for the Evaluation of Daylight Factors in Existing Buildings in Sweden**

Downloaded from: <https://research.chalmers.se>, 2026-04-03 12:36 UTC

Citation for the original published paper (version of record):

Eriksson, S., Waldenstrom, L., Tillberg, M. et al (2019). Numerical Simulations and Empirical Data for the Evaluation of Daylight Factors in Existing Buildings in Sweden. *Energies*, 12(11). <http://dx.doi.org/10.3390/en12112200>

N.B. When citing this work, cite the original published paper.

Article

# Numerical Simulations and Empirical Data for the Evaluation of Daylight Factors in Existing Buildings in Sweden

Sara Eriksson <sup>1</sup>, Lovisa Waldenström <sup>1</sup>, Max Tillberg <sup>1,\*</sup>, Magnus Österbring <sup>2</sup> and Angela Sasic Kalagasidis <sup>3</sup> 

<sup>1</sup> Bengt Dahlgren AB, Kroksläotts Fabriker 52, 431 37 Gothenburg, Sweden;

sara.eriksson@bengtdahlgren.se (S.E.); lovisa.waldenstrom@bengtdahlgren.se (L.W.)

<sup>2</sup> NCC Sweden, Gullbergs Strandgata 2, 411 04 Gothenburg, Sweden; magnus.osterbring@ncc.se

<sup>3</sup> Chalmers University of Technology, Department of Architecture and Civil Engineering, Sven Hultins gata 6, SE-41296 Gothenburg, Sweden; angela.sasic@chalmers.se

\* Correspondence: max.tillberg@bengtdahlgren.se

Received: 26 April 2019; Accepted: 5 June 2019; Published: 10 June 2019



**Abstract:** Point Daylight Factor ( $DF_P$ ) has been used for daylighting design in Sweden for more than 40 years. Progressive densification of urban environments, in combination with stricter regulations on energy performance and indoor environmental quality of buildings, creates complex daylight design challenges that cannot be adequately solved with  $DF_P$ . To support a development of the current and future daylight indicators in the Swedish context, the authors have developed a comprehensive methodology for the evaluation of daylight levels in existing buildings. The methodology comprises sample buildings of various use and their digital replicas in 3D, detailed numerical simulations and correlations of diverse DF metrics in existing buildings, a field investigation on residents' satisfaction with available daylight levels in their homes, and a comparison between the numerical and experimental data. The study was deliberately limited to the evaluation of DF metrics for their intuitive understanding and easy evaluation in real design projects. The sample buildings represent typical architectural styles and building technologies between 1887 and 2013 in Gothenburg and include eight residential buildings, two office buildings, two schools, two student apartment buildings, and two hospitals. Although the simulated  $DF_P$  is 1.4% on average, i.e., above the required 1%, large variations have been found between the studied 1200 rooms. The empirical data generally support the findings from the numerical simulations, but also bring unique insights in the residences' preferences for rooms with good daylight. The most remarkable result is related to kitchens, typically the spaces with the lowest DF values, based on simulations, while the residents wish them to be the spaces with the most daylight. Finally, the work introduces a new DF metric, denoted  $DF_W$ , which allows daylighting design in early stages when only limited data on the building shape and windows' arrangement are available.

**Keywords:** daylight; existing buildings; daylight factor; daylight simulations; daylight survey

## 1. Introduction

Point Daylight Factor ( $DF_P$ ) is an official criterion for daylighting design of buildings in Sweden. It was introduced after the 1970's energy crisis to secure a minimum daylight quantity in indoor environments and, thereby, to counterbalance stricter regulations on limited energy use for space heating [1]. The minimum requirement for  $DF_P$  has been set to 1% at a specified point in an indoor space where people stay for a longer time and where the nature of their activities requires access to daylight. Despite its known limitations, such as the inability to describe temporal variations and

perceived quality of daylight in a space, where the latter according to [2–4] is composed of both physical metrics and psychological criteria, its simple definition and resource-efficient evaluation during the building design have determined its decades long presence in the Swedish building regulations [5].

DF<sub>P</sub> may be pragmatic, but it is also a rather rigid design criterion, which creates various indecisive situations during a building's design. As pointed by national experts in daylighting design [6], the 1% target is challenging to achieve in buildings located in densified urban areas, in situations where architectural appearance and functional aspects of a building are differently valued in the building's design, or in indoor spaces of irregular shapes. Sweden experiences a positive internal migration of population to larger cities [7], which, in combination with high prices of municipal land and a need for better techno-economic utilization of the existing infrastructure, leads to an increased densification of urban areas [8]. Placement of new buildings among the existing ones, rather than in the outskirts of a city, decreases the amount of available daylight in these areas over time. Similar outcomes are noticeable after buildings' refurbishment projects, when the addition of new floors on tops of the existing buildings is needed to balance the costs of the refurbishment. Furthermore, trends in architecture that favor vertical window shapes, deep volumes, and less reflective interior finishes are more likely to create larger contrasts and uneven daylight distribution indoors [9], which are difficult to describe by DF<sub>P</sub>. Moreover, DF<sub>P</sub> is subjective to different interpretations in rooms with irregular, e.g., polygon-type layouts [10]. Finally, the current DF<sub>P</sub> requirement, or any other daylight metrics, is literally not achievable in northern parts of the country during the several-months-long periods of total darkness at high geographical latitudes. These everyday design challenges have encouraged national experts in daylighting design to review the current and future development needs for daylight indicators in the Swedish context [6,11].

Since the late 1990s, climate-based modelling software has provided fairly accurate predictions of daylight distribution in interiors by taking into account realistic sun and sky conditions [12]. This has allowed various spatial and temporal averaging of daylight availability in a space and definitions of new daylight criteria such as daylight coefficient (DC), useful daylight illuminance, etc. [13–17]. Prior to choosing one or another refined daylight indicator, at least the following two practical aspects need to be carefully considered: Resources needed for the implementation of new criteria in real projects and satisfaction of end-users (residents) with the available daylight levels in existing buildings. The former is of a large importance in the early design stages, when the building geometry and fenestration are reconfigured many times before a satisfactory architectural solution is found. If energy and daylighting design of the building cannot follow the other design activities due to, e.g., time-consuming simulations, the targeted energy and daylight performances will be coarsely estimated, and any mistakes made thereby will be difficult to correct during the detailed building design. As for the daylight levels in existing buildings, a common sense would say the more the better. At the same time, the most densified urban areas in Sweden, like in many other parts of the world, are the most attractive for habitation and work despite a generally low availability of daylight. This indicates that residents adapt to a range of daylight metrics instead of just a single value, as it is commonly defined in building regulations and certification systems. This paper aims to clarify these practical aspects based on the results of a comprehensive study conducted by [10].

### 1.1. Daylighting Indicators and Calculation Techniques in Use

Along with introducing DF<sub>P</sub> in the Swedish building regulations, daylight protractors were recommended for the quantification of DF<sub>P</sub>. The manual reading of daylight components and correction factors for various design situations was shown to be time-consuming, i.e., expensive in respect to the projects' costs and, thus, not used by practitioners in a desired extent [6]. To simplify the daylighting design, the so called 'AF method' was introduced in 1988, with 'AF' referring to the window-to-floor ratio [18].

$$A_{\text{glazing}} \geq f \cdot A_{\text{floor}}, \quad (1)$$

where  $A_{\text{glazing}}$  and  $A_{\text{floor}}$  are the window and the floor area in  $[\text{m}^2]$ , respectively, and  $f$  is a constant to be chosen with respect to obstructions in front of the window. To reach a  $\text{DF}_P$  of about 1% in a room, the values for  $f$  should be chosen between 0.075 to 1.5, for low to high obstruction angles.

Since the AF method was introduced, only small adjustments in the daylight design were made. Both  $\text{DF}_P$  and AF are still in use, with the difference being that  $\text{DF}_P$  is considered a more precise criterion whose value should be quantified by means of validated software such, as Daylight visualizer [19] and Radiance [20], while AF is adequate for simpler design situations [18]. For example, the Swedish environmental certification method Miljöbyggnad (Green building) provides target values for both  $\text{DF}_P$  and AF for the basic grade, 'bronze', which indicates a compliance with ruling building regulations, as well as for the medium grade, 'silver', while only  $\text{DF}_P$  is accepted for the highest grade, 'gold' [21]. The Nordic Swan Ecolabel aims at stringent environmental and functional qualities and thus approves only  $\text{DF}_P$  [22].

Sweden has systematically worked on the regulatory policies on energy use in buildings over the past decades, which has resulted in low energy use in buildings despite the cold climate [23]. Similar positive outcomes on indoor environmental quality can be expected from the stricter national regulations and standards related to daylighting design. However, new demands will be challenged by budget constraints in a design process. With the prevailing performance-based design, i.e., the lack of formative standards on how the buildings' energy design should be conducted, one can expect that stricter regulations on daylighting design will, sooner or later, trigger the invention of simplified design indicators and calculation methods.

### 1.2. Daylight Availability in Existing Buildings

Despite affordable daylight simulation tools and a satisfactory accuracy between the simulated and measured daylight levels in buildings [24], comprehensive studies on actual daylight levels in existing buildings are rare. Most of the available studies are performed on representative models of rooms or buildings, e.g., [25–29]. In that sense, the study done by [30], who considered  $\text{DF}_P$  in several apartments of an existing residential building in Hong Kong, was rather unique. To the best of the authors' knowledge, comparable results for Sweden were produced for the first time by [10], who calculated different daylight metrics in 16 sample buildings of various purposes in the city of Gothenburg. By using different techniques, including the AF method and detailed numerical simulations in Radiance, both point and area averaged DF (mean and median) were quantified in about 1200 rooms in the sample buildings. Furthermore, a qualitative assessment of the daylight availability was obtained from interviews with tenants in selected sample buildings. Moreover, a new DF metric,  $\text{DF}_W$ , has been proposed for daylighting design in the early stages. The numerical approach of [10] was adopted by [31], who quantified the same daylight metrics, i.e., the point and area averaged DF, in the 54 sample buildings of the city of Stockholm, expanding the pool of numerical results for Sweden. For supporting future studies on daylight availability in existing buildings by using DF metrics, this paper introduces the methodology of [10] in a full extent, including both simplified and detailed numerical calculations, questionnaires and results from the field survey, and suggestions on how  $\text{DF}_W$  can be used in early stages. To the best of the authors' knowledge, the only example of DF metrics like  $\text{DF}_W$  can be found in the work by [32] which is one of the follow-up studies of [10].

### 1.3. The Layout of the Paper

This paper presents two types of results, as follows: The calculated, i.e., theoretically possible indoor illuminance levels in Swedish buildings, and a qualitative assessment of the resident's satisfaction with the available indoor illuminance in selected sample buildings. Section 2 presents the overall research methodology and starts with a rationale behind the sample buildings, including a brief description of their morphology and technical characteristics. Thereafter, the procedure of constructing CAD replicas of the sample buildings is introduced together with the calculation settings. A definition of the used DF metrics, reference calculation points with examples of situations where intentional

adjustments of the reference points were made is presented in the continuation. Finally, an in-house questionnaire that was used in the field studies is presented at the very end of Section 2. Results of numerical simulations of  $DF_p$  in the sample buildings are enclosed in Section 3. Correlations between various point and area averaged DF metrics are presented and discussed in Section 4. At the very end of Section 4, a correlation between the calculated  $DF_p$  levels and those from the field study is shown. Conclusions from the entire work are shown in Section 5.

## 2. Research Methodology

To get good insight into the available amounts of daylight in buildings, it was decided the study would be performed on existing buildings and by using DF metrics that were known to daylight designers in Sweden. Since all authors of this work are from Gothenburg, the sample buildings were selected in the same city for purely practical reasons, namely a good insight in daylight challenges in the city and an easy access to the buildings' documentation from the city administration and private archives.

A substantial part of the work was spent on creating computer aided drawings (CAD) of the sample buildings and their surroundings, in three-dimensions (3D). Generally, floor plans were created in AutoCAD (2014), while 3D drawings were done in Rhinoceros 5. The latter was chosen strategically for its compatibility with the daylight simulation software Daysim, which was used for outdoor daylight simulations, and Radiance, for indoor daylight distributions. Daysim and Radiance are accessed through Diva and used in conjunction with the Grasshopper plugin [33]. The buildings surrounding the sample buildings were reconstructed as simpler 3D objects by using a digital 3D map of the city [34].

Since the aim of this study was to get an insight in theoretically possible indoor illuminance in the sample buildings, rather than to quantify the actual indoor illuminance, no specific validation of the calculated results was performed. The daylight simulations used in this work are well-known and widely used for daylight design investigations, and for which a variety of validation results exist. Based on the results from the reported validation studies, such as [13,25,33,35–37] it was concluded that the accuracy of Diva is sufficient for the complexity of the daylighting design investigations enclosed in the study.

Definitions and a practical assessment of the used DF metrics for various daylight situations in the studied buildings is presented by means of illustrative examples. The survey on residents' satisfaction with the daylight availability in their homes was limited to three residential buildings due to a short time frame (about three months). The average response rate was 67%, which was found satisfactory for making comparisons with the results of numerical studies.

### 2.1. Sample Buildings and Their CAD Replicas

Given that this numerical study was the first of its kind in Sweden, the sample buildings were selected in a close cooperation with local daylight experts to assure a good representation of daylighting design challenges. The available buildings' documentation and the limited time for the study, six months in total, also influenced the choice of buildings. In total, sixteen existing multistore buildings were included in the study, wherein eight were residential, while the remaining types included student apartments, offices, schools, and hospitals, each represented by two samples.

When selecting the buildings, their primary use and age were considered together, as a compound criterion reflecting the buildings' architectural and technical standards, as well as their location in the city. It should be noted that Gothenburg is a medium size city (the second largest in the country) with about 600,000 inhabitants and a rather fragmented urban fabric. Although all studied buildings are in the city area (see Figure 1), those grouped at the south bank of the river (ID 1, 3, 2, 10, 12, and 16) are in the oldest, somewhat more densified area than the other buildings. Further details about the sample buildings are summarized in Table 1 and complementary street photos can be found in Section 4.

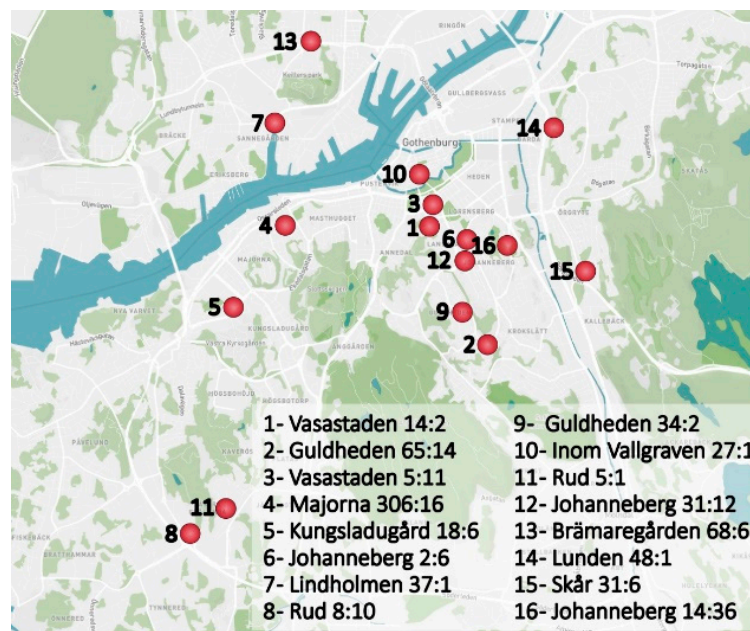

**Figure 1.** Location of the studied buildings in Gothenburg. The cadastral numbers are shown next to the ID.

**Table 1.** Main characteristics of the studied buildings. Year = year of construction. Use: R-residential, S-school, O-office, H-hospital, SA-student apartment (micro apartment). Only the floors with the same layout were used, in accordance with the main use of the building.

ID	Characteristics	Year	Use	Total Number of Floors	Number of Evaluated Floors	Number of Evaluated Rooms
1	Elongated apartment block	1972	R	6	4	36
2	Tower block	1960	R	12	8	200
3	Townhouse with a courtyard	1887	R	4	4	42
4	Governor's house with a courtyard	1897	R	4	3	140
5	Governor's house with a courtyard	1923	R	3	3	37
6	L-shaped apartment block	1928	R	6	5	70
7	Compact tower block	2013	R	11	4	68
8	Compact tower block	1960	R	10	4	100
9	Compact block	2004	SA	5	3	97
10	Townhouse with two street sides	1863	O	5	4	47
11	Low-rise, elongated	1962	S	2	2	14
12	L-shaped compact block	2006	SA	13	5	230
13	Low-rise compact block	1966	H	4	4	38
14	Low-rise, indented top floor	2006	O	3	3	36
15	U-shaped, low-rise with a school yard	2001	S	2	2	30
16	Block with a tower on one side	1927	H	4	3	52
Total						1237

Typical features of the buildings built around the turn of the 20th century (IDs 3, 4, 5, 6, 10 and, 16 in Table 1.) are brick masonry, deep floor plans, low window-to-floor ratios, and sides facing courtyards. The buildings built between the years 1960 and 1972 (IDs 1, 2, 8, 11, and 13) are typically high-rise or elongated tower blocks of pre-fabricated concrete elements, with shallow floor plans and rather large windows, often arranged in serials. Finally, the new buildings built after the year 2000 (IDs 7, 12, 14, and 15) are of higher energy standards compared to the other sample buildings, which is reflected in deeper window niches due to thick thermal insulation in walls. Other features of the modern buildings include energy windows, with U-values around  $1 \text{ W/m}^2\text{K}$ , and deep and open floor plans.

To optimize the drawing process, only floors with the same layout were considered, following the main purpose of a building. Floors excluded from the study were those with storage or rentable spaces,

i.e., of another purpose than the main use of a building in question. In total, more than 1200 spaces were evaluated.

As mentioned earlier, the quality of available blueprints was also an influential criterion, when selecting the sample buildings, in order to enable the creation of precise CAD drawings of the buildings' interiors and exteriors for the daylight simulations. The blueprints were mostly obtained as scanned floor plans and sections from the City Planning Authority of Gothenburg. If several blueprints from different periods were available for a building, the newest ones were used for its CAD replica. Older blueprints were consulted in cases where some information was missing in the newer blueprints. The process of creating CAD drawings of the studied buildings is depicted in Figure 2. Two-dimensional floorplans were drawn in AutoCAD 2014, using the available blueprints as templates. These were then imported to Rhinoceros 5 to create three dimensional drawings by adding sections and facades.

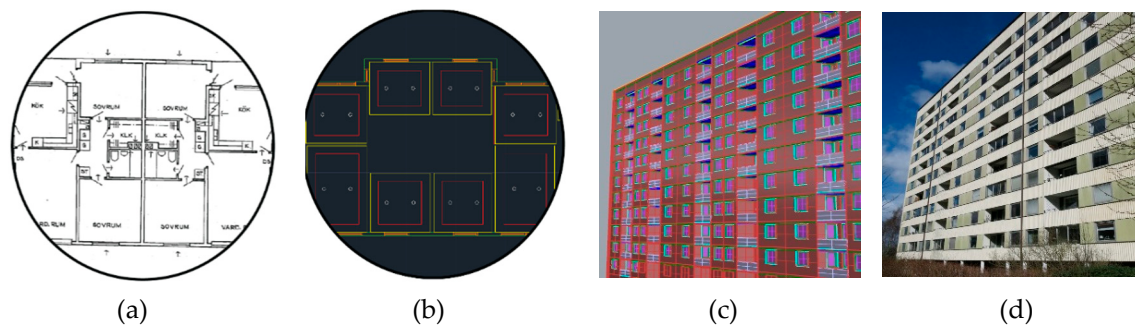

**Figure 2.** Creating CAD replicas of a building: (a) the original (scanned) blueprint of a floor plan; (b) the same floor plan redrawn in AutoCAD; (c) a 3D model of the building in Rhino, reconstructed from the floor plans; and (d) a photo of the actual building (ID 2).

## 2.2. Optical Properties of Surfaces

Since the aim of the study was to show the access to daylight in the existing buildings, rather than the exact levels of daylight, two major simplifications were made in the simulations. The first relates to the optical properties of interior and exterior surfaces. The light transmission of glass is assumed to be 0.70 since the window glass currently used in Swedish housing is normally between 0.65 and 0.75 [11]. Reflectance of specific interior and exterior surfaces was decided in consultations with the daylight designers [6], as presented in Table 2, and used as set of constants throughout the daylight simulations. This simplification was found necessary for both practical and methodological reasons. At the time of the study, exact data about the optical properties of the surfaces were not available. By assigning different yet assumed optical properties, the calculated DF metrics would be systematically biased from the presented results, but the relative difference between the studied rooms would remain the same. Another advantage of using the same optical properties was in reducing the number of possible causes for differences between the studied rooms. An exception was made for balcony railings, since their optical properties vary greatly with their opacity. For completely opaque balcony railings, a reflectance of 0.3 was assumed, i.e., the same as for external facades. For semi-transparent and transparent balcony railings, the reflectance and transmittance were assumed in the range 0.3 to 0.7. The second simplification refers to the interior geometrical objects, such as furniture. These were neglected in the simulations for the sake of simplicity.

**Table 2.** Reflectance of different objects as used in this study. Reproduced with permission from [6].

Object	Reflectance	Object	Reflectance
Outside ground	0.2	Window frame	0.8
External façades	0.3	Side of window	0.5
Surrounding buildings and objects	0.2	Balcony	0.3
Floor	0.3	Balcony bottom	0.7
Walls	0.7	Water	0.5
Ceiling	0.8	Roof	0.3

### 2.3. Calculation of Indoor and Outdoor Illuminance

When quantifying DF metrics, the illuminance from the overcast sky reaching a surface or a point on a building was calculated by the sky view factor (SVF) and sky exposure factor (SEF), respectively. For all sample buildings, SEF and SVF were calculated in Grasshopper by considering the buildings' surroundings (neighboring buildings, streets, ground, and sky), and by using the same calculation points and grids as used for the definition of area-averaged DFs. As mentioned earlier, the shape of surrounding buildings was based on a 3D digital map of the city [34] and introduced in Grasshopper as three-dimensional CAD-drawings (see 'Surroundings' in Figure 3). Based on the analysis in Section 2.6, SVF and SEF produced similar results.

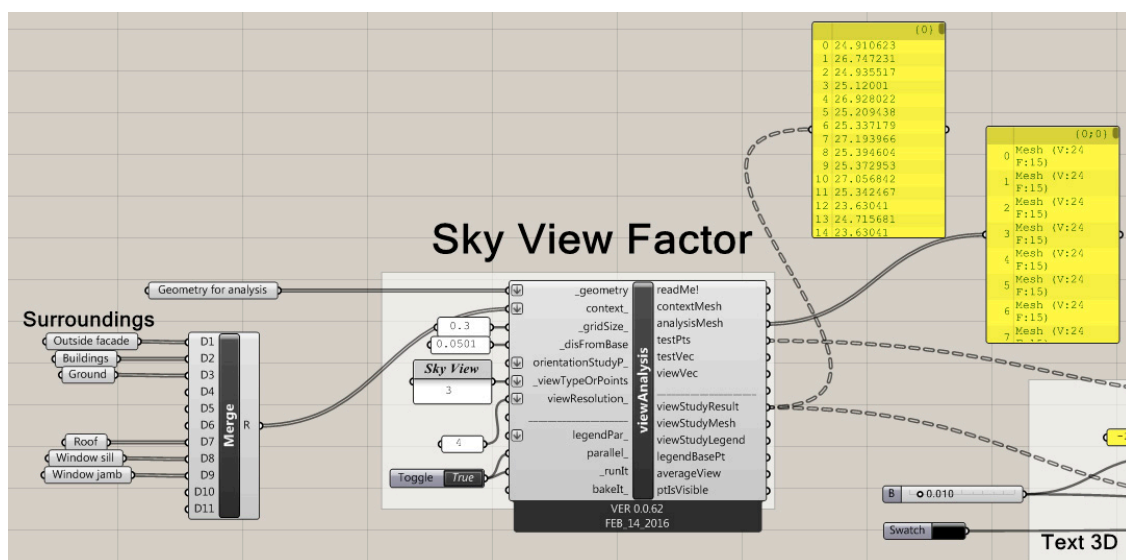
**Figure 3.** Calculation of the sky view factor in Grasshopper.

For the grid-based simulations of indoor illuminance in Radiance, the following five settings were used: The number of ambient bounces (-ab 7), the ambient divisions (-ad 2048), the ambient super-samples (-as 512), the ambient resolution (-ar 256), and the accuracy (-aa 0.1). These settings were found in an iterative manner, by optimizing results' convergence in relation to the simulation time. It is worth noting that all calculation points and grids were defined in two-dimensional models in AutoCAD to simplify the creation of computational grids in the three-dimensional models in Radiance.

### 2.4. Control Points for $DF_p$ in Complex Rooms

Based on the instructions in standard [38], the control point for  $DF_p$  calculations should be placed at half of the room depth, one meter from the darkest inner wall and 0.85 m above the floor. While this rule is easily applied on rectangular, single-purpose rooms, it requires certain interpretations for rooms with complex layouts or in multi-purpose rooms. During this work, these challenges were encountered numerous times and examples on how these were solved are provided below.

A rectangular multi-purpose room, composed of a kitchen and a dining room, is shown in Figure 4. By following the instructions factually, the control point for this room should be placed between these two partitions where it would not have any practical value. Instead, a fictitious wall was added between the kitchen and the dining room in the daylight simulations. The two new control points were defined in accordance with the standard, each better describing the areas where people would stay for an extended time.

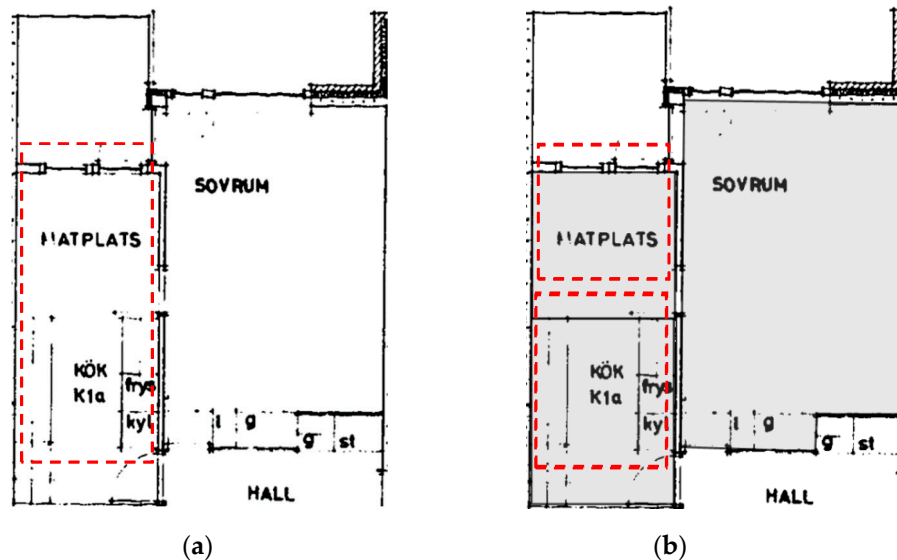

**Figure 4.** Separation of an open floor plan into two entities: (a) The original plan with a kitchen and a dining room (within the dashed line) and (b) a wall added between these two rooms for  $DF_p$  calculations.

Single-purpose rooms of polygonal shape typically have an unclear definition of room depth, as shown in Figure 5a, or a clear direction of the room depth but variable depths, as in Figure 5b. In these and similar cases,  $DF_p$  was evaluated at an average room depth, calculated from the viable options.

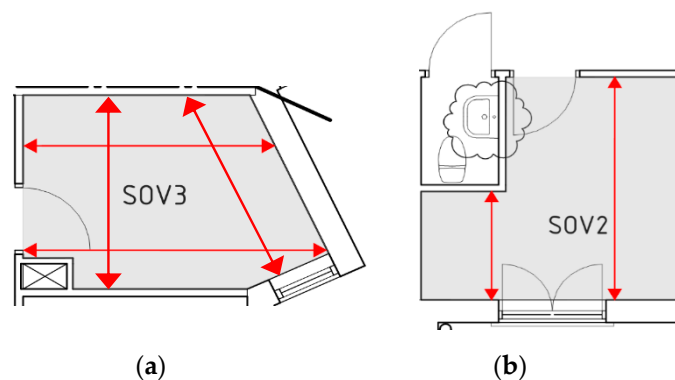

**Figure 5.** Rooms with varying room depths in: (a) Different directions and (b) one direction.

In multi-purpose rooms with a polygonal layout, typically found in new buildings where a kitchen and a living room are combined into one open space, as shown in Figure 6,  $DF_p$  was calculated at several control points (marked in red circles), all fulfilling the requirement presented in the standard. The point with the lowest  $DF_p$  value was then chosen as the final control point (red dots).



**Figure 6.** Examples of combined kitchens and living rooms that result in complex floor layouts. Acceptable positions for the evaluation of single-point DF are indicated with circles. Positions with the lowest calculated single-point DF are shown by dots.

### 2.5. Control Surfaces and Grids for Area-Averaged DF

Due to the uncertainties in finding a control point for the evaluation of  $DF_P$  in complex rooms, described above, complementary calculations of area-averaged DF-values were conducted for all the studied rooms. The two following types of control surfaces were used, as shown in Figure 7: A whole horizontal section at 0.85 m from the floor and a horizontal area at the same height, but retracted 0.5 m from each wall. The rationale behind the retracted control surface was to focus on the area wherein people would spend longer times.

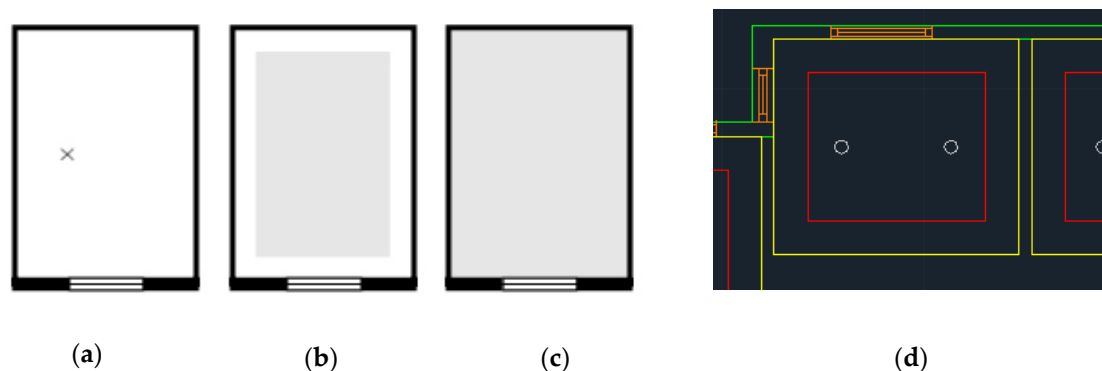

**Figure 7.** Control points and control surfaces for DF calculations in a room: (a) The control point for  $DF_P$ ; (b), and the retracted and (c) whole control surface for  $DF_A$  and  $DF_M$ . (d) A drawing of a floor plan in AutoCAD with the control points (white circles) and the retracted and the whole control surfaces, enclosed by the red and yellow rectangles, respectively.

When calculating the indoor illuminance, calculation points in each control surface were placed in a uniform rectangular grid, at 0.3 m distance. From the grid-point values, the mean  $DF_A$  and median  $DF_M$  were calculated. For each room, four area-averaged DF values, namely  $DF_A$  and  $DF_M$  for both the full and the retracted control surface, and one  $DF_P$  were found.

### 2.6. New Daylight Metrics: $DF_W$

Traditionally, DF metrics are calculated for buildings' interiors. However, in early stage designs, only a rough building shape and window arrangements are known, but not the floor layouts. To avoid conflicting situations between the energy and daylight performance of a building, which are typically revealed during the detailed design stage, i.e., after the architectural design is finalized, a new daylight design criterion was introduced, reading as follows:

$$DF_W = \frac{\text{Area averaged outdoor illuminance in front of a window}}{\text{Outdoor illuminance (unobstructed)}} \times 100 [\%]. \quad (2)$$

This definition is based on a hypothesis that it is possible to establish a unique and predictive correlation between  $DF_W$  and  $DF_P$  for a room. To calculate the area-averaged illuminance in front of a window, a control surface was defined at 0.05 m distance from the vertical plane on the exterior side of the window. As in the case of area-averaged DF inside a room, calculation points were placed in a rectangular grid at 0.3 m distance. An example of the calculation grid is shown in Figure 8. The correlation of  $DF_W$  and  $DF_P$  is evaluated in Section 3, by using the residential buildings as case studies. From the obtained correlations, the usefulness of  $DF_W$  is evaluated.

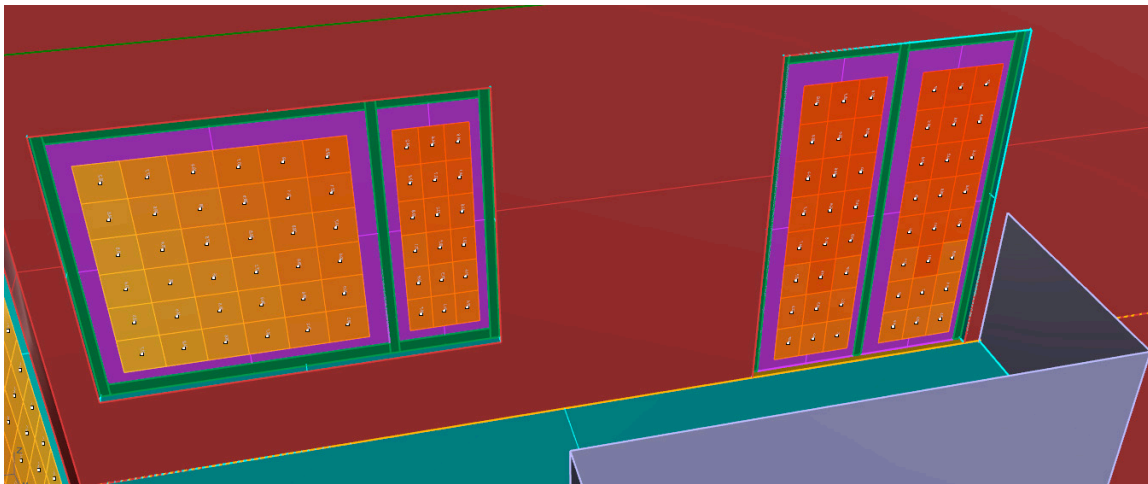

**Figure 8.** Calculation grids outside the windows in Rhinoceros.

When calculating  $DF_W$ , it is of large importance that the outdoor illuminance is correctly modelled. For that purpose, the illuminance from the overcast sky reaching a surface or a point on a building was calculated by the sky view factor (SVF) and the sky exposure factor (SEF), and compared to  $DF_W$  from Equation (2). The result of this comparison is presented in Figure 9 for buildings with ID 1, 2, and 3. The values are organized in ascending order, after  $DF_W$ . As it can be seen, these three methods give nearly the same values. The somewhat larger difference between  $DF_W$  and the other two metrics for the lower percentages on the y-axis can be explained by external reflections from the surroundings, which are only considered when calculating  $DF_W$ . In the higher range, all three indicators almost coincide since there are nearly no external reflections.

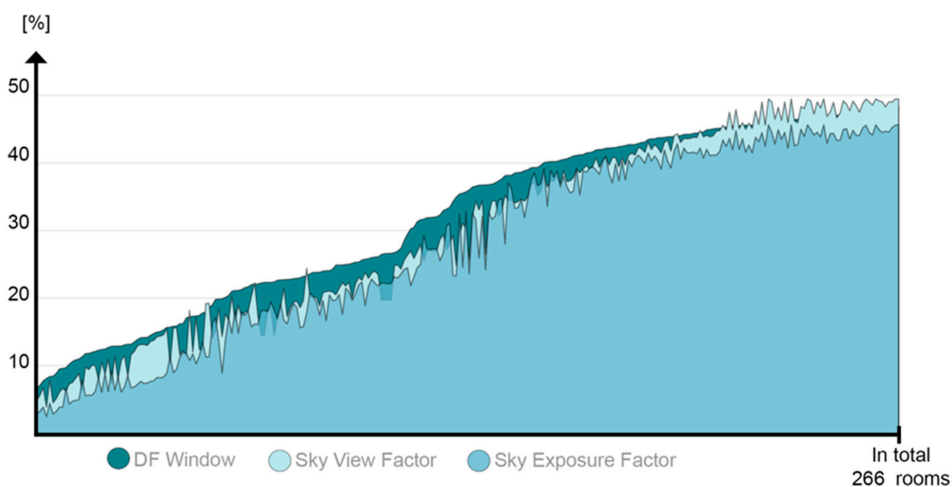

**Figure 9.** Daylight factor, sky view factor, and sky exposure factor measured outside the windows. The values are organized after the size of the daylight factor.

## 2.7. Field Surveys

To gain a better understanding of the calculation results, a survey for the residents of three residential buildings of substantially different age and design was distributed, with IDs 2 (tower block from 1960), 6 (L-shaped apartment block from 1928), and 7 (compact tower from 2013). More details about the buildings can be found in Table 1 and Figure 1.

The survey was composed of nine questions focusing on the residents' satisfaction with the amount of available daylight in specific rooms. Answers were collected as grades and then compiled and compared to the simulated results, as shown in Section 4.4. Answers were received from 45 out of 67 apartments, corresponding to an average response rate of 67% (see Table 3).

**Table 3.** Number of distributed and collected surveys for the selected residential buildings.

ID	Number of Distributed Surveys	Number of Collected Surveys	Response Rate
2	36	24	67%
6	15	8	53%
7	16	13	81%
All	67	45	67%

The questions were asked in Swedish and their provisional translations to English read as follows:

- Q1. How do you perceive the access to daylight in the following rooms?
- Q2. Would you prefer more or less daylight in these following rooms?
- Q3. Which room type do you think is the most important room to have the greatest access to daylight?
- Q4. Do you normally use electrical lighting daytime in the following rooms?
- Q5. Do you have access to direct sunlight in the following rooms?
- Q6. Do you often use curtains, blinds or other sun shadings in the following rooms?
- Q7. In case of using a sun shading, why is it used?
- Q8. Do you consider the view out to be interesting in the following rooms? (Quantity)
- Q9. Do you consider the view out to be enough in the following rooms? (Quality)

Except for questions Q3 and Q7, all other questions were to be answered with a scaled answer and for a specific room, to allow comparisons with the simulated daylight factors in the room.

## 3. Results: Simulated $DF_p$ in the Sample Buildings

A selection of the most indicative results and data analysis is presented hereafter. As DF is commonly calculated at a single point in Sweden, the calculated single-point DF values are firstly presented and grouped per the building use. Comparisons between the single-point and area-averaged DF values is shown in the next section.

### 3.1. Residential Buildings (IDs 1–8)

The distribution of the calculated single-point  $DF_p$  in all considered rooms in the residential buildings with the IDs 1–8 is shown in Figure 10. The current threshold value on 1% is shown by the vertical dashed line. Only the habitable rooms, i.e., bedrooms, kitchens, living rooms, and dining rooms in the residential buildings, were simulated. The results indicate a significant difference between the buildings, but also within the same building. The most striking are the results for building number 3, without a single room fulfilling the current requirement on  $DF_p$ . This is a direct consequence of large room depths and ceiling heights in comparison to the position and size of the windows. Narrow buildings, such as IDs 2, 4, and 8, have a significant percentage of rooms fulfilling the current daylight requirement. However, none of the buildings meet the requirement in all the studied rooms, not even in the newest building from 2013 (ID 7).

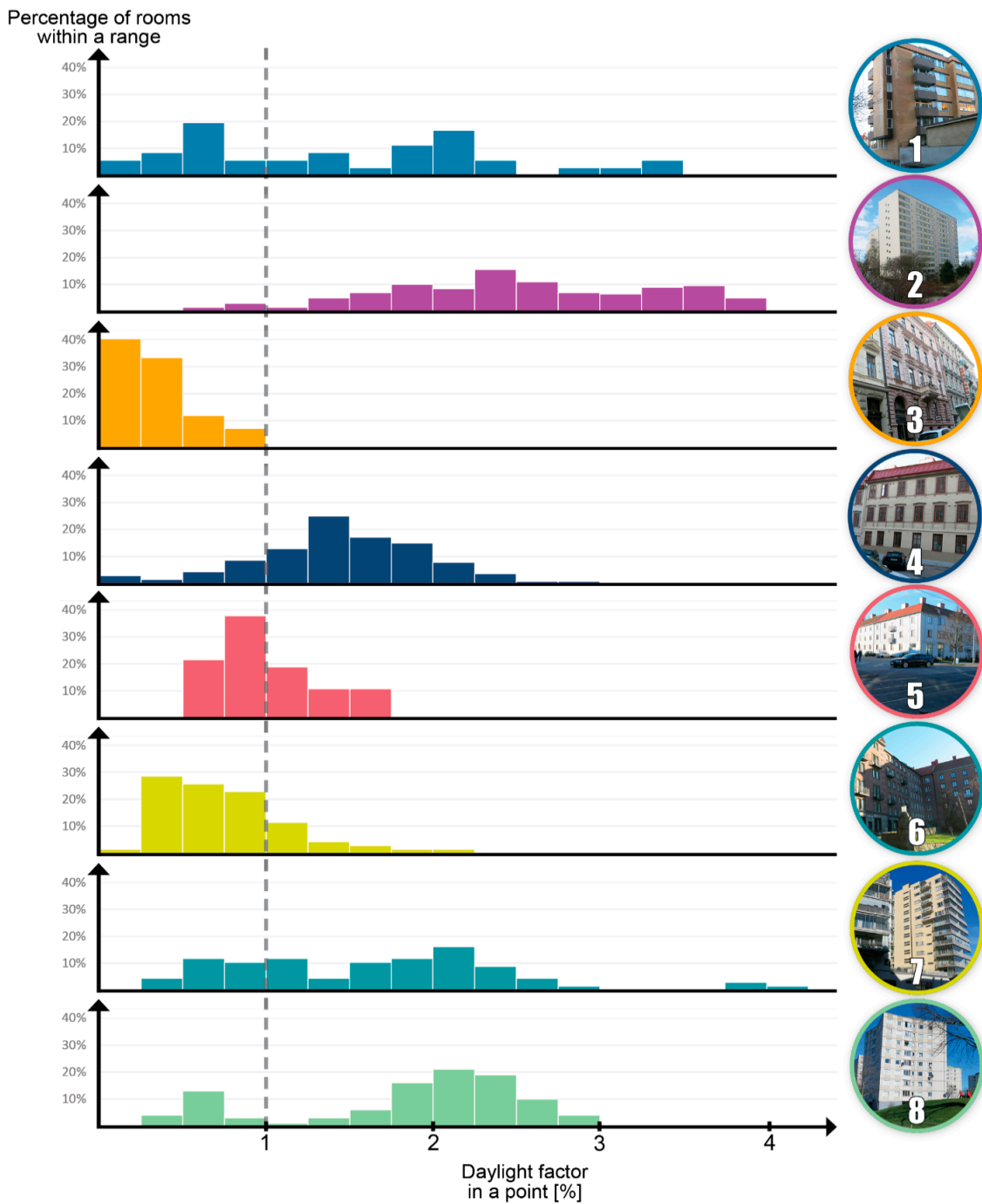
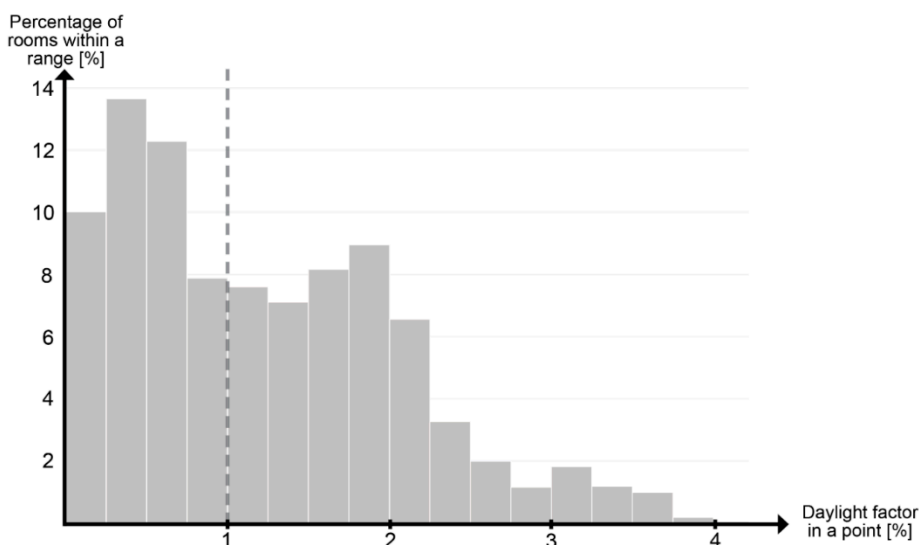

**Figure 10.** Distribution of  $DF_p$  in all the simulated rooms in the residential buildings.

The percentage of the studied rooms with a  $DF_p$  greater than 1% and the average  $DF_p$  for each studied building is shown in Table 4. The total averages are also included, showing that the requirement is fulfilled in 71% of the studied rooms at the average  $DF_p$  of 1.67%. However, given that the number of rooms varies largely between the buildings (see Table 1), these simple averages can be biased in favor of the buildings with larger number of rooms. This is confirmed by the weighted averages in Figure 11, which show that 56% of rooms fulfil the requirement of 1% and that weighted average  $DF_p$  is about 1.4%.

**Table 4.** The percentage of rooms with the single-point DF greater than 1% in the residential buildings.

Building ID	Percentage of All Rooms with a DF > 1%	Average DF for a Building
1	61%	1.47%
2	96%	2.50%
3	0%	0.31%
4	83%	1.45%
5	41%	1.01%
6	21%	0.74%
7	74%	1.65%
8	80%	1.85%
Average for all rooms/buildings	71%	1.67%



**Figure 11.** Distribution of the weighted single-points DF in the residential buildings.

The  $DF_p$  results have been further split per room type and are shown in Figure 12. Since the studied rooms have different names in the original drawings, they have been grouped into four main types, namely bedroom, living room, kitchen, and dining room, as presented in Table 5. Based on the calculations, kitchen is the room type that has the least amount of daylight in general. A reasonable explanation for this can be found in the kitchen placement, which is often further inside the building, sometimes behind other rooms. There are few results for the dining rooms, mainly because there were very few distinct rooms of this type in the analysis.

**Table 5.** Shows all the different room types studied, divided into the four main categories.

Bedroom	Living Room	Kitchen	Dining Room
Bedroom	Living room	Kitchen	Dining room
Small room	Family room	Divided kitchen	Divided dining
	Living room/Bedroom	Divided kitchenette	
	Living room/Kitchen	Living room/Kitchen	

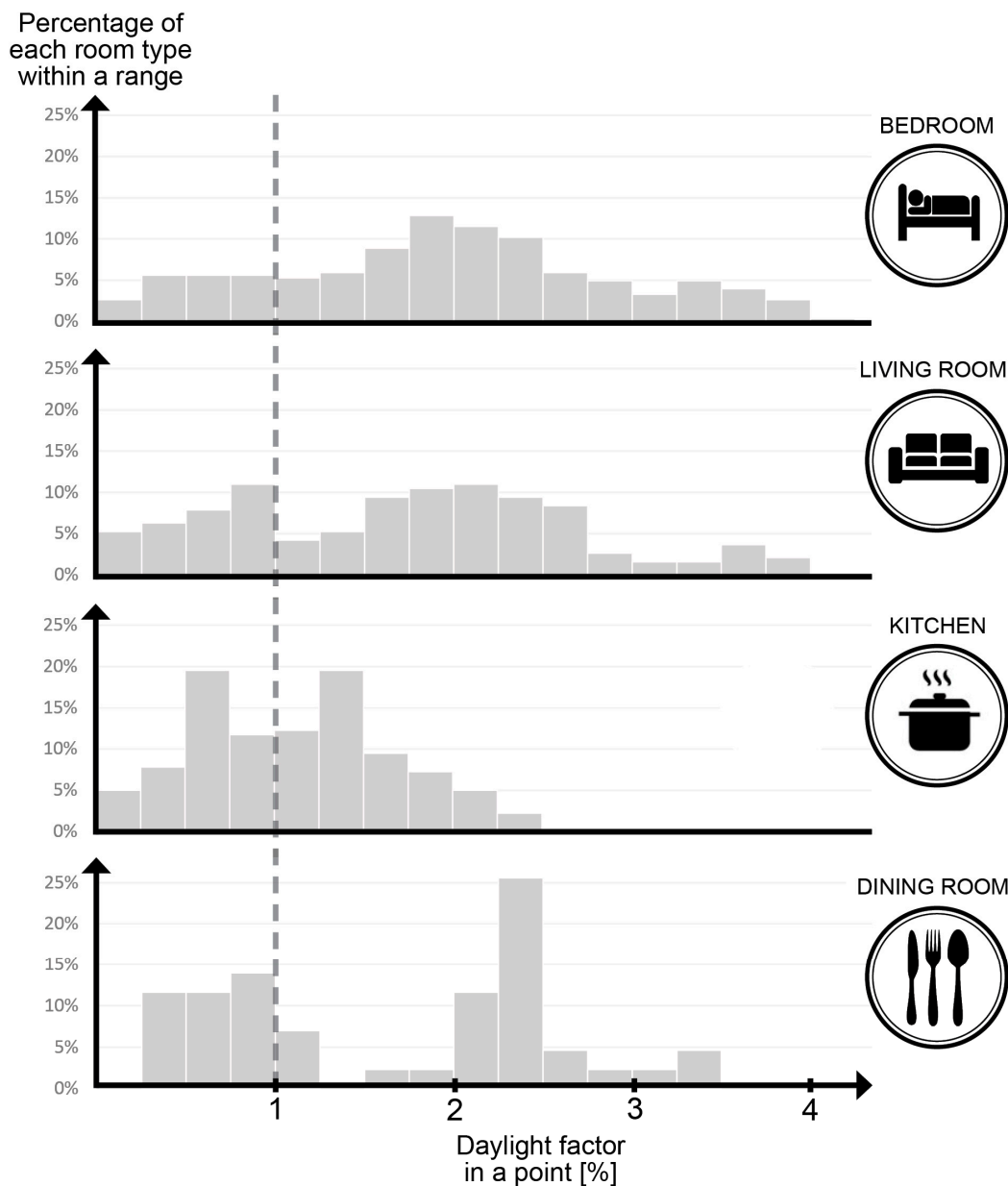
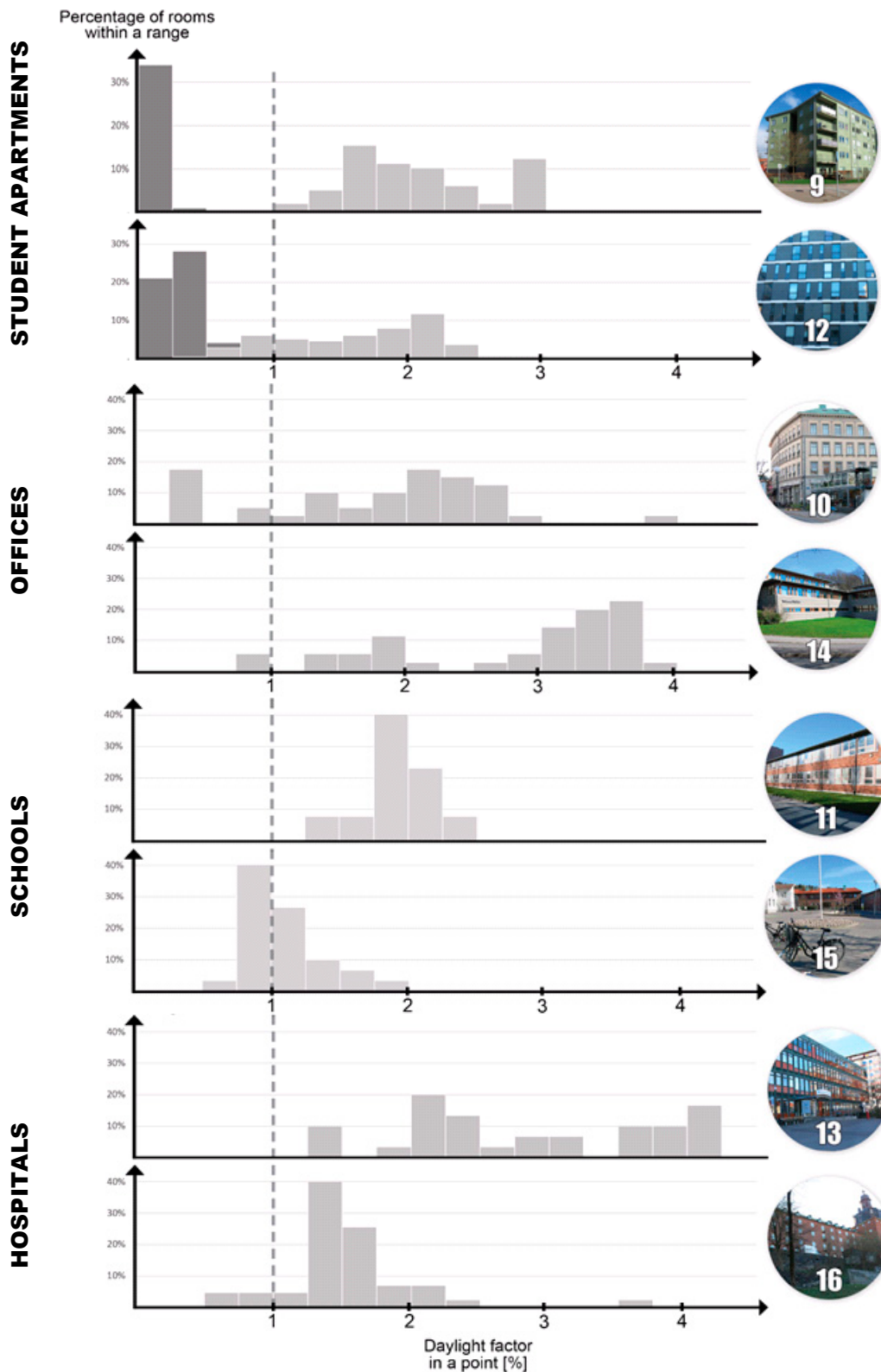

Figure 12. Distribution of  $DF_p$  per room type.

### 3.2. Non-Residential Buildings (ID 9 to ID 16)

The distribution of  $DF_p$  in the non-residential buildings is shown in Figure 13. It is worth noting that the requirement for  $DF_p$  in student apartment buildings (ID 9 and ID12) is basically the same as in residential buildings, except in rooms intended for cooking, where it is enough to have access to indirect daylight. Regardless, the kitchenettes were also included in this study for comparisons. The dark grey bars represent kitchenettes and the light grey ones are for other rooms, such as bedrooms, living rooms, and combined rooms (bedroom and living room). Based on the results,  $DF_p$  in the bedrooms, living rooms, and combined rooms is mostly above the requirement. All kitchenettes, on the other hand, have  $DF_p$  below 0.75% because they are typically placed further into the building, behind other rooms.



**Figure 13.** Distribution of  $DF_p$  in the student non-residential buildings. For the student apartment buildings, the kitchenettes are marked in dark grey and all other rooms in light grey.

Moving on to the office buildings with IDs 10 and 14, the results indicate that the most of the rooms have a rather high  $DF_p$ . An explanation for this can be found in the small size of the cell-type offices and, particularly, their small depth in comparison to the size of the windows. In both schools

(ID 11 and ID 15), merely the classrooms have been studied. In building 11, the daylight factor is around 2% while, in building 15, the daylight factor is a bit lower in general, around 1%. Finally, the majority of studied rooms in the hospitals (ID 13 and ID 16), i.e., examination rooms, patient rooms, and offices, have a daylight factor within a range. In contrast to the student apartment buildings, offices, and hospitals, none of the rooms in the schools have a daylight factor above 2.5%. A reasonable explanation for this is that the depths of the classrooms are generally greater, in comparison to other room types, and, therefore, the point where the daylight factor is measured is placed further into the buildings.

#### 4. Results – Correlation Between Different DF Metrics

##### 4.1. Correlation Between $DF_P$ , $DF_A$ and $DF_M$

The area-averaged DFs from Section 2.4, i.e.,  $DF_A$  and  $DF_M$  are alternative metrics for describing the daylight availability in rooms. Therefore, the correlations between the single-point DFs for the residential buildings, from Section 3, and their area-averaged equivalents are shown in Figure 14. The latter comprise the following four values: An average or a median value, over a whole or a retracted horizontal area. Only the rooms (more than 95%, approximately) where the position of a control-point for  $DF_P$  could be clearly defined were included in the comparisons.

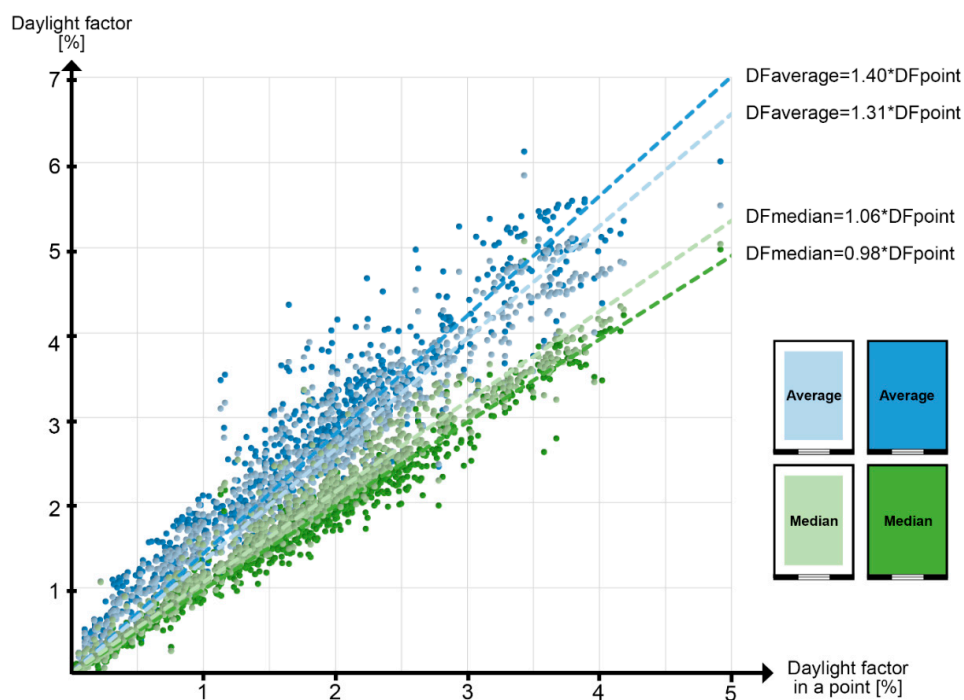

**Figure 14.** Comparison between the point-value  $DF_P$  (horizontal axis) and area-averaged DFs ( $DF_A = DF_{average}$ ,  $DF_M = DF_{median}$ , vertical axis), for both full and retracted control surfaces.

As it can be seen, there is almost a 1:1 correlation between the  $DF_P$  and  $DF_M$  for both control surfaces, while  $DF_A$  is about 30–40% larger than  $DF_P$ . This is because the smaller (retracted) control surface affects  $DF_A$  and  $DF_M$  differently;  $DF_M$  generally increases while  $DF_A$  decreases. This trend can be explained by the example in Figure 15, which shows a DF distribution in a simple rectangular room with a window. When retracting the control surface by 0.5 m from each wall, a greater part of the values below the median value is removed. Consequently, the median value for the retracted control surface increases.

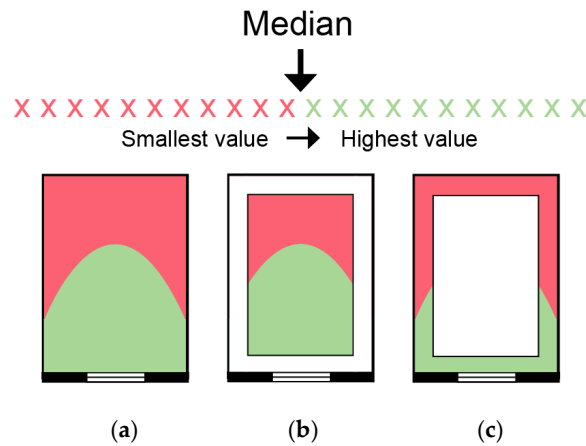

**Figure 15.** Impact of the size of a control area on the results of ordinary mean and median DF: (a) the control area covers the whole horizontal section; (b) the control area is retracted 0.5 m from the inner walls; (c) the difference between (a) and (b). The green zone represents the area in the room were the daylight factor is above the median value, while the red zone represents the area in the room were the daylight factor is below the median value.

One needs to look at DF values at each point in the grid to understand the effects of the control surface retraction on the DF-averages. This has been done for four different room types, as shown in Figure 16. Each graph in the figure shows the calculated grid-points DFs in ascending order. The points with the highest DFs, placed closest to the windows, are basically truncated when the control surface is reduced. This applies also to the points with the lowest DFs, which are furthest from the windows. In the rooms with non-linear distributions of DFs, the truncation of the highest DF-values has a greater impact on the average DF (i.e., it decreases) then in the rooms with a linear distribution of DFs.

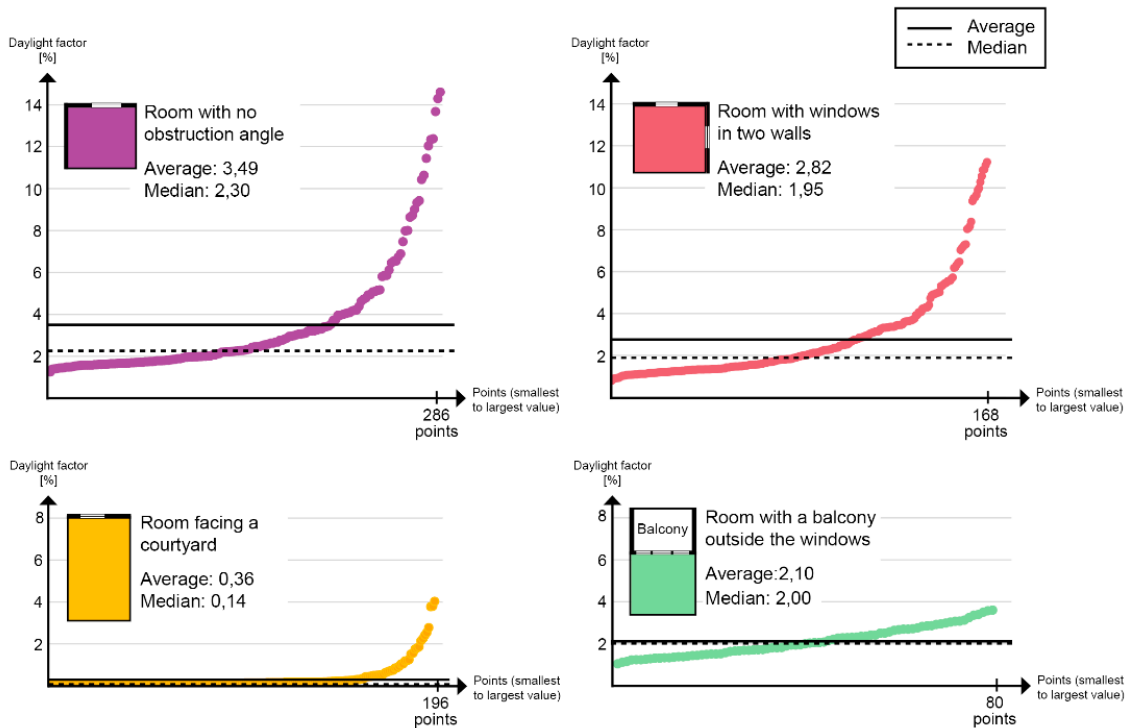

**Figure 16.** Grid-point values of DF arraigned in ascending order, for four different room types. The corresponding average and median values for the same control surfaces are also included.

#### 4.2. Correlation Between $DF_p$ and AF

As presented in the introductory section, the AF method is a simpler and, thus, widely used method for the daylight design of buildings. To evaluate its reliability, the AF method was applied to the studied buildings and the results were compared to the single-point DF calculations presented in Section 3. It is worth noting that the AF method only indicates a probability that the DF in a room will be greater than 1%, rather than the actual amount of daylight indoors.

Based on the instructions in [38], the AF method can be applied to simpler room geometries and shading situations, which, in this study, stands for about 61% of the studied rooms. Among those, in 78% of cases there was an agreement between the calculated single-point DF and the assessment by the AF-method; 70% with good daylight (both  $DF \geq 1\%$  and the requirement in equation 2 fulfilled) and 8% with poor daylight. In the remaining 22%, there was a disagreement between these two methods as presented in Table 6.

**Table 6.** Comparison between the results from the AF-method and single-point DF calculations.

Results for AF	Results for $DF_p$	Percentage of the Studied Rooms	Agreement between the Methods
$A_{\text{glazing}} \geq f \cdot A_{\text{floor}}$	$DF_p \geq 1\%$	70%	Yes
$A_{\text{glazing}} < f \cdot A_{\text{floor}}$	$DF_p < 1\%$	8%	Yes
$A_{\text{glazing}} \geq f \cdot A_{\text{floor}}$	$DF_p < 1\%$	12%	No
$A_{\text{glazing}} < f \cdot A_{\text{floor}}$	$DF_p \geq 1\%$	10%	No

The main reason for this disagreement can be found in the limitations of the AF method. The AF method works only in two dimensions, i.e., in a vertical section, without considering lateral objects and situations, as shown in Figure 17. In addition, rooms with windows with different directions and heights, or rooms placed behind other rooms, are basically not possible to evaluate using this method.

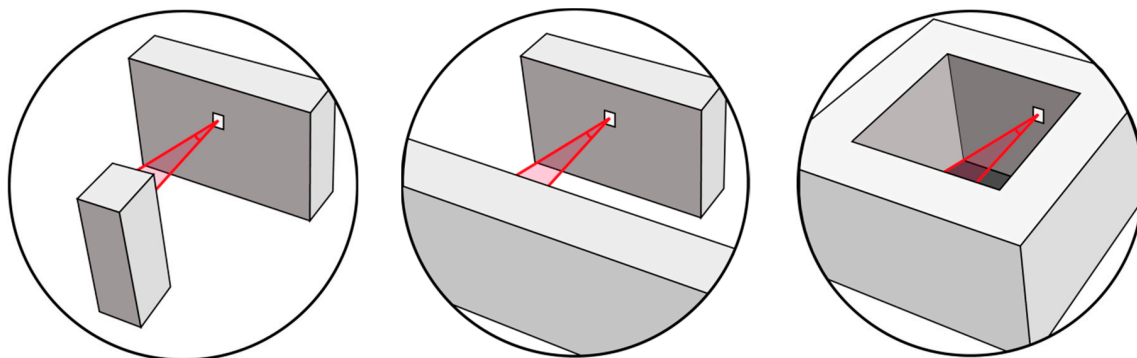

**Figure 17.** Three situations for which the AF-method gives the same results (by anticipating the same obstruction angle in front of the window), while the  $DF_p$  method gives the different results.

#### 4.3. Correlation Between Daylight Factors Indoors and $DF_W$

The available daylight in front of windows, described by Equation (3),  $DF_W$ , was calculated for the residential buildings with IDs 2, 3, and 6, with the largest, medium, and lowest  $DF_p$  metrics indoors, respectively (see Figure 10). Examples of  $DF_W$  for selected windows are shown in Figure 18. As expected,  $DF_W$  reaches much higher values than DF inside the rooms. The range of calculated values was between 7% and 46%.

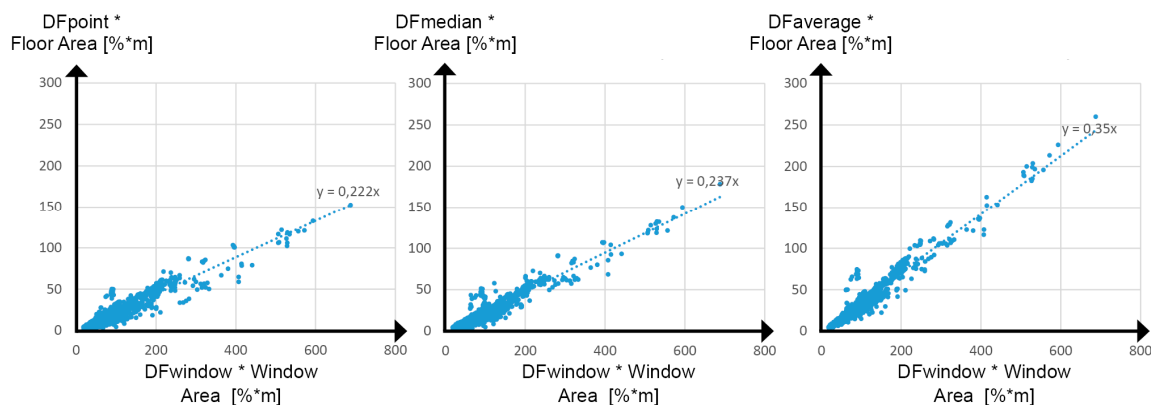

**Figure 18.** Examples of different daylight factors outside selected windows in buildings 2, 3, and 6.

Amounts of daylight inside a room and in front of windows are strongly correlated to the floor and window size. When multiplying  $DF_W$  and the area of windows, the resulting value (in  $\% \cdot m^2$ ) can be interpreted as an indication of the available daylight entering a room. A similar result can be obtained when  $DF_P$  and the area-averaged DFs are multiplied with the full floor area in the room. The corresponding products are compared in Figure 19. Based on the results of the regression analyses, the following relations can be established:

$$\begin{aligned} DF_P \cdot A_{\text{floor}} &\approx 0.22 \cdot DF_W \cdot A_{\text{window}}, \\ DF_M \cdot A_{\text{floor}} &\approx 0.24 \cdot DF_W \cdot A_{\text{window}}, \\ DF_A \cdot A_{\text{floor}} &\approx 0.35 \cdot DF_W \cdot A_{\text{window}}. \end{aligned} \quad (3)$$

Although the established relations are rough, with the coefficient of determination about 0.8, they are also indicative and could be of use as guiding values in the early design stages, in the Swedish design context.



**Figure 19.** Correlation between the simulated amount of daylight outside the windows ( $DF_W$  multiplied by the window area) and indoors. The latter is given, for three DF indicators, each multiplied by the floor area.

#### 4.4. Correlation Between $DF_P$ and Results of the Field Survey

As mentioned in Section 2.7, answers on all questions but Q3 and Q7 were in form of grades, to allow comparisons with the simulated daylight factors in the room. An example of such a comparison can be found in Figure 20, which shows the  $DF_P$  (in ascending order) for all 124 evaluated rooms, together with the scaled answers from question Q1. These were further correlated by a polynomial trend line, included in the figure as a dashed line to indicate a general trend of the answers.

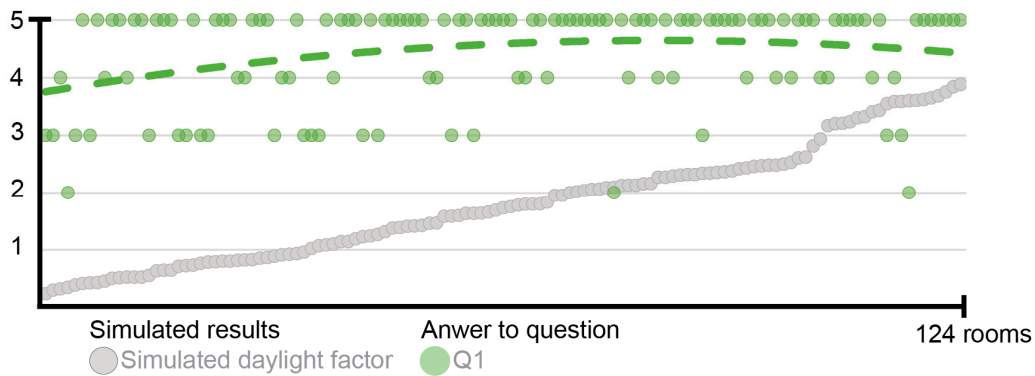

**Figure 20.** Simulated single-point DF and the scaled answers to question Q1 from the residents. The dashed line is a fitted polynomial to the answers from residents.

The same procedure was used to process and compare the results on questions Q2, Q4–Q6, and Q8–Q9 with the calculated DF, as shown in Figure 21. As can be seen in the figure, there is a general agreement between the perceived access to daylight (Q1) and the calculated DF; people give higher grades to the rooms with higher DF. A similar but stronger correlation can be found between the perceived access to direct sunlight (Q5) and the DF, which can be explained in two ways, as follows: People may find the access to daylight better in sunlit rooms because the rooms get brighter at these moments, or because the sunlit rooms are truly exposed to more daylight due to fewer shading objects in the surroundings.

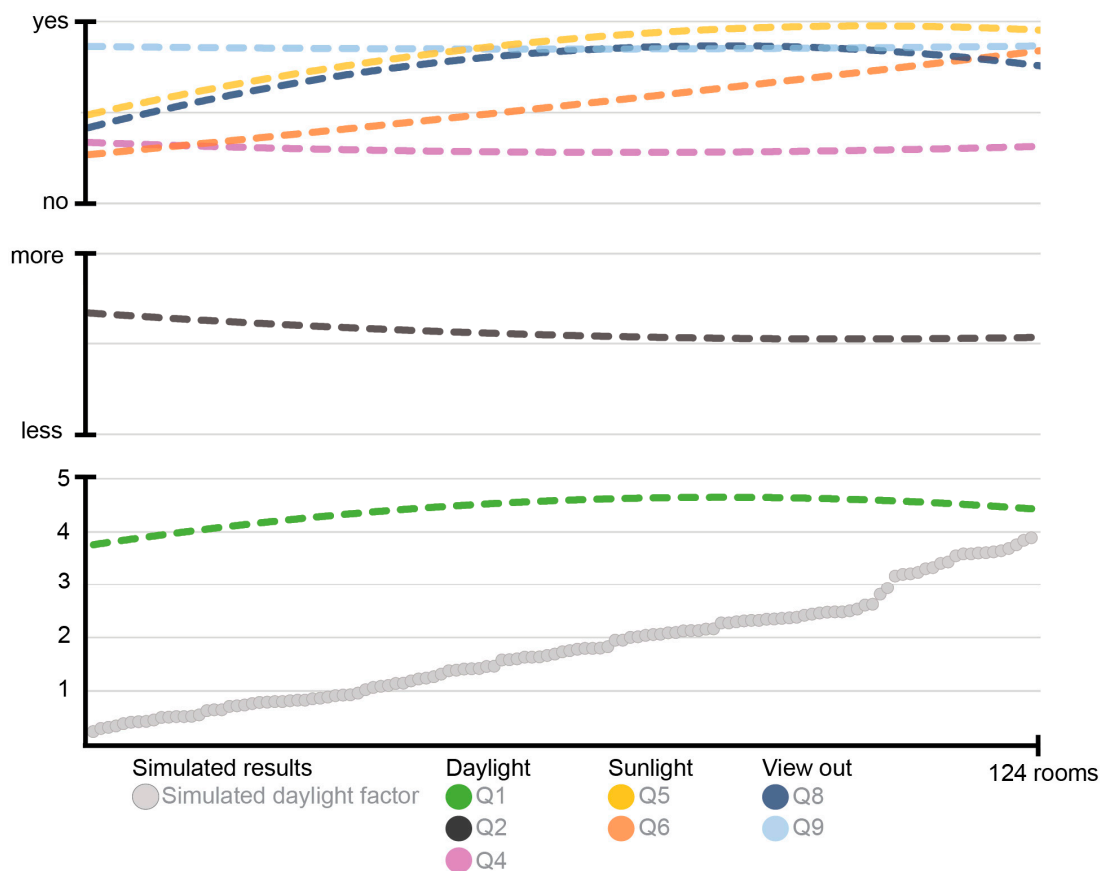

**Figure 21.** Trendlines (dashed lines) based on the scaled answers from the survey, compared to the calculated single-point DF for all 124 rooms.

Answers to question Q2 reveal how content the residents had been when assessing the access of daylight in their apartments. Most of respondents, i.e., 79%, were pleased with the current daylight levels, while 17% and 4% would like to have more and less daylight, respectively. These results are also in agreement with the answers to Q1.

Question Q3 showed in which rooms the residents would like to have the most daylight. Four different room types were considered (kitchen, living room, bedroom, and dining room) and the residents ranked them 1–4, where 1 was the most important room. The average grades for each room type, in Figure 22, show that the kitchen was ranked as the most important room to have access to a lot of daylight, while the bedroom as the least important one. These results are very interesting because they are in a direct contradiction with the findings from Figure 12, i.e., the kitchens normally have the least access to daylight (the lowest single-point DF), much lower than the bedrooms (the majority with a DF larger than 1%). The results from the surveys alone are not enough to make reliable conclusions about how the residents perceive the daylight in their homes. They can, however, indicate what people desire, in general.

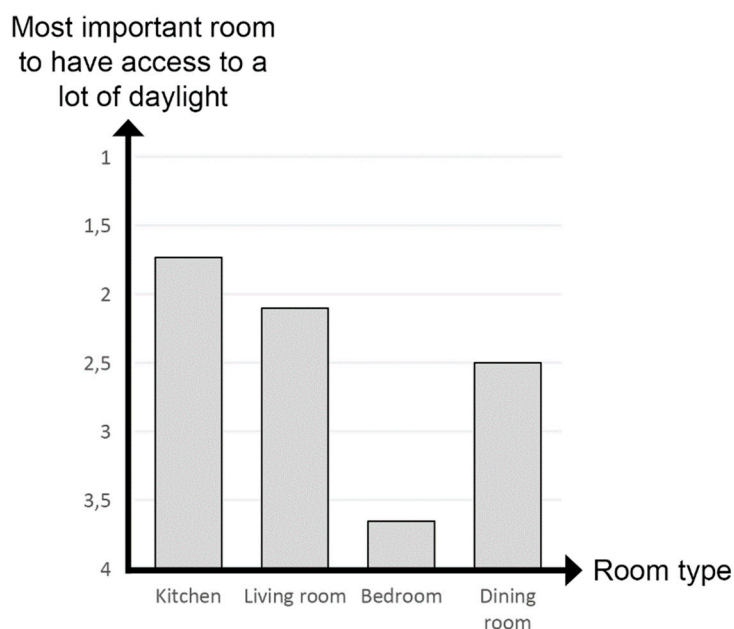

**Figure 22.** The residents' priorities regarding the most important room to have much access to daylight.

## 5. Conclusions

To evaluate daylight levels in existing buildings in the Swedish context and, thereby, to support an ongoing review of the current and future daylight indicators in Sweden, comprehensive numerical simulations of various DF metrics in more than 1200 rooms of 16 sample buildings were conducted. The study was deliberately limited to the evaluation of DF metrics for their intuitive understanding and easy evaluation in real projects. The sample buildings represent typical architectural styles and building technologies, from between 1887 and 2013, in Gothenburg and include eight residential buildings, two office buildings, two schools, two student apartment buildings, and two hospitals. Although the simulated point daylight factor  $DF_P$  is found to be 1.4% on average, which is above the required 1%, large variations were found between the studied rooms.

For overcoming various indecisive situations when evaluating  $DF_P$ , alternative DF metrics were introduced, i.e., the mean  $DF_A$  and median  $DF_M$ , both averaged over the same horizontal surface in a room, by considering either the full surface or the retracted area (by 0.5 m from all walls). Based on regression analyses, almost 1:1 correlation was found between  $DF_P$  and  $DF_M$ , while  $DF_A$  gave typically 30–40% larger amounts of daylight in the rooms, compared to  $DF_P$ . It was shown that this difference is a consequence of a non-linear distribution of the daylight over the control surface, for which  $DF_M$  is

more suitable. In addition, results for  $DF_p$  in selected sample buildings were compared to the ones obtained by the AF method, which is another broadly used daylight design method in Sweden. This comparison basically confirmed the known limitations of the AF method, i.e., that the AF method is suitable only for simpler daylight design tasks.

The field investigation, aimed at revealing the residents' satisfaction with available daylight levels in selected sample buildings by means of an in-house questionnaire, brought some further and unique insights in daylight design challenges. It was found that the empirical data generally supported the findings from the numerical simulations of  $DF_p$ . This is particularly valid for kitchens, the spaces with the lowest  $DF_p$  values, based on simulations. While the empirical data confirm that kitchens are the spaces with the lowest amounts of daylights, they also indicate that the residents would like kitchens to be the spaces with the most daylight.

A new DF metric, denoted  $DF_w$ , allowing for daylighting design in early stages, when only limited data on the building shape and windows arrangement are available, is introduced and evaluated. The latter was done through a regression analysis with the results based on the calculated  $DF_p$ ,  $DF_A$ , and  $DF_M$  values. Rough, but rather indicative, correlations were found between  $DF_w$  and other DF metrics, indicating that the former could be of use in the early design stages in the Swedish design context.

It is worth noticing that the findings may look different for different sample buildings and urban constellations, as was shown in [31], who used the methodology developed by the authors of this work. Yet, the developed methodology is general and can be applied for further studies. The combination of numerical and field studies is particularly important for spaces where lower DF levels are identified by simulations. In this regard, the future work should focus on field studies of perceived daylight levels in schools, since these were shown to be generally lower than in the other non-residential buildings studied.

**Author Contributions:** Conceptualization and methodology, all authors; formal analysis, investigation and visualization, L.W. and S.E.; validation, L.W., S.E., and M.T.; writing—original draft, L.W., S.E., A.S.K., and M.Ö.; writing—review and editing, A.S.K. and M.Ö.; supervision, M.T., M.Ö., and A.S.K.

**Funding:** This research received no external funding.

**Acknowledgments:** Anna Larsson and Mats-Inge Olsson from Bengt Dahlgren AB in Gothenburg are acknowledged for providing supervision and necessary drawings.

**Conflicts of Interest:** The authors declare no conflict of interest.

## References

1. Boverket. *SBN 1975 Svensk Byggnorm*. 1975. Available online: <https://www.boverket.se/contentassets/c4c3f9ae57294ae889bfaf710b08b125/sbn-1975-utg-3.pdf> (accessed on 30 May 2019).
2. Xue, P.; Mak, C.M.; Cheung, H.D. The effects of daylighting and human behavior on luminous comfort in residential buildings: A questionnaire survey. *Build. Environ.* **2014**, *81*, 51–59. [CrossRef]
3. Cheung, H.D.; Chung, T.M. A study on subjective preference to daylit residential indoor environment using conjoint analysis. *Build. Environ.* **2008**, *43*, 2101–2111. [CrossRef]
4. Cantin, F.; Dubois, M.-C. Daylighting metrics based on illuminance, distribution, glare and directivity. *Light. Res. Technol.* **2011**, *43*, 291–307. [CrossRef]
5. Boverket. *BBR Boverket's building regulations*. BFS 2011:6 with amendments up to 2018:4 (in Swedish). 2018. Available online: [https://www.boverket.se/globalassets/publikationer/dokument/2018/bbr-2018\\_konsoliderad-version.pdf](https://www.boverket.se/globalassets/publikationer/dokument/2018/bbr-2018_konsoliderad-version.pdf) (accessed on 30 May 2019).
6. Rogers, P.; Tillberg, M.; Bialecka-Colin, E.; Österbring, M.; Mars, P. *En Genomgång av Svenska Dagsljuskra*v 2015. Available online: <http://www.acc-glas.se/wp-content/uploads/2013/12/SBUF-12996-Slutrapport-Förstudie-Dagsljusstandard.pdf> (accessed on 30 May 2019).
7. Boverket. *Housing, Internal Migration and Economic Growth in Sweden*. (In Swedish). 2016. Available online: <https://www.boverket.se/globalassets/publikationer/dokument/2016/housing-internal-migration-and-economic-growth-in-sweden.pdf> (accessed on 30 May 2019).

8. Strømmand-Andersen, J.; Sattrup, P. The urban canyon and building energy use: Urban density versus daylight and passive solar gains. *Energy Build.* **2011**, *43*, 2011–2020. [[CrossRef](#)]
9. Robinson, A.; Selkowitz, S. Tips for Daylighting with Windows. Available online: [https://buildings.lbl.gov/sites/default/files/ellen\\_thomas\\_lbnl-6902e.pdf](https://buildings.lbl.gov/sites/default/files/ellen_thomas_lbnl-6902e.pdf) (accessed on 14 April 2019).
10. Eriksson, S.; Waldenström, L. Daylight in Existing Buildings A Comparative Study of Calculated Indicators for Daylight. Master's Thesis, Chalmers University of Technology, Gothenburg, Sweden, 2016.
11. Rogers, P.; Dubois, M.-C.; Tillberg, M.; Östbring, M. Moderniserad Dagsljusstandard. no. SBUF ID: 13209. 2018. Available online: <http://www.acc-glas.se/wp-content/uploads/2013/12/SBUF-12996-Slutrapport-Förstudie-Dagsljusstandard.pdf> (accessed on 30 May 2019).
12. Mardaljevic, J.; Christoffersen, J. A Roadmap for Upgrading National/EU Standards for Daylight. In Proceedings of the CIE Centenary Conference “Towards a New Century of Light”, Paris, France, 15–16 April 2013; pp. 1–10.
13. Reinhart, C.; Breton, P.-F. Experimental validation of 3DS MAX<sup>®</sup> DESIGN 2009 and DAYSIM 3.0 1 2. In Proceedings of the 11th International IBPSA Conference, Glasgow, Scotland, 27–30 July 2009.
14. Mardaljevic, J.; Andersen, M.; Roy, N.; Christoffersen, J. Daylighting metrics for residential buildings. In Proceedings of the 27th Session CIE, Sun City, South Africa, 11–15 July 2011; p. 18.
15. Hellinga, H.; Hordijk, T. The D&V analysis method: A method for the analysis of daylight access and view quality. *Build. Environ.* **2014**, *79*, 101–114.
16. Yu, X.; Su, Y. Daylight availability assessment and its potential energy saving estimation -A literature review. *Renew. Sustain. Energy Rev.* **2015**, *52*, 494–503. [[CrossRef](#)]
17. Tregenza, P. Uncertainty in daylight calculations. *Light. Res. Technol.* **2017**, *49*, 829–844. [[CrossRef](#)]
18. SIS. SS 914201 *Building design - Daylighting - Simplified method for checking required window glass area*; SIS Swedish Standards Institute: Stockholm, Sweden, 1988.
19. Velux. *Daylight Visualizer*. 2019. Available online: <https://www.velux.com/article/2016/daylight-visualizer> (accessed on 30 May 2019).
20. Radsite. *Radiance*. 2019. Available online: <https://www.radiance-online.org/> (accessed on 20 April 2016).
21. SGBC. *Miljöbyggnad 3.0*; Sweden Green Building Council: Stockholm, Sweden, 2017.
22. Ecolabelling, N. Small Houses, Apartment Buildings and Buildings for Schools and Pre-Schools. 2016. Available online: [https://www.ecolabel.dk/kriteriedokumenter/089e\\_2\\_11.pdf](https://www.ecolabel.dk/kriteriedokumenter/089e_2_11.pdf) (accessed on 20 March 2016).
23. Mata, É.; Kalagasidis, A.S.; Johnsson, F. Energy usage and technical potential for energy saving measures in the Swedish residential building stock. *Energy Policy* **2013**, *55*, 404–414. [[CrossRef](#)]
24. Yu, X.; Su, Y.; Chen, X. Application of RELUX simulation to investigate energy saving potential from daylighting in a new educational building in UK. *Energy Build.* **2014**, *74*, 191–202. [[CrossRef](#)]
25. Mardaljevic, J. Simulation of annual daylighting profiles for internal illuminance. *Light. Res. Technol.* **2000**, *32*, 111–118. [[CrossRef](#)]
26. Li, D.; Cheung, G. Average daylight factor for the 15 CIE standard skies. *Light. Res. Technol.* **2006**, *38*, 137–152. [[CrossRef](#)]
27. Li, D.H.W.; Wong, S.L. Daylighting and energy implications due to shading effects from nearby buildings. *Appl. Energy* **2007**, *84*, 1199–1209. [[CrossRef](#)]
28. Dubois, M.-C.; Flodberg, K. Daylight utilisation in perimeter office rooms at high latitudes: Investigation by computer simulation. *Light. Res. Technol.* **2013**, *45*, 52–75. [[CrossRef](#)]
29. Thomsen, K.E.; Rose, J.; Mørck, O.; Jensen, S.Ø.; Østergaard, I.; Knudsen, H.N.; Bergsøe, N.C. Energy consumption and indoor climate in a residential building before and after comprehensive energy retrofitting. *Energy Build.* **2016**, *123*, 8–16. [[CrossRef](#)]
30. Li, D.; Wong, S.; Tsang, C.; Cheung, G.H. A study of the daylighting performance and energy use in heavily obstructed residential buildings via computer simulation techniques. *Energy Build.* **2006**, *38*, 1343–1348. [[CrossRef](#)]
31. Bournas, I.; Dubois, M.-C. Daylight regulation compliance of existing multi-family apartment blocks in Sweden. *Build. Environ.* **2019**, *150*, 254–265. [[CrossRef](#)]
32. Jacobsson, E.; Eriksson, F. Evaluation of Sun-and Daylight Availability in Early Stages of Building Development A Method Based on Correlations of Interior and Exterior Metrics. Master's Thesis, Chalmers University of Technology, Gothenburg, Sweden, 2017.

33. Reinhart, C.F.; Lagios, K.; Niemasz, J.; Jakubiec, A. DIVA for Rhino Version 2.0. 2011. Available online: <http://www.diva-for-rhino.com/> (accessed on 30 April 2016).
34. Chalmers Geodata Portal. Available online: <https://geodata.chalmers.se/> (accessed on 22 April 2019).
35. Bellia, L.; Pedace, A.; Fragliasso, F. The impact of the software's choice on dynamic daylight simulations' results: A comparison between Daysim and 3ds Max Design®. *Sol. Energy* **2015**, *122*, 249–263. [[CrossRef](#)]
36. Jones, N.L. Validated Interactive Daylighting Analysis for Architectural Design. Ph.D. Thesis, Massachusetts Institute of Technology, Cambridge, MA, USA, 2017.
37. Nocera, F.; Faro, A.L.; Costanzo, V.; Raciti, C. Daylight Performance of Classrooms in a Mediterranean School Heritage Building. *Sustainability* **2018**, *10*, 3705. [[CrossRef](#)]
38. SIS. "SS-EN 17037-2018 Daylight in buildings."; SIS Swedish Standards Institute: Stockholm, Sweden, 2018.



© 2019 by the authors. Licensee MDPI, Basel, Switzerland. This article is an open access article distributed under the terms and conditions of the Creative Commons Attribution (CC BY) license (<http://creativecommons.org/licenses/by/4.0/>).