

THESIS FOR THE DEGREE OF LICENCIATE OF ENGINEERING

Direct-Ground Cooling Systems for Office Buildings: Design and Control Considerations

Taha Arghand

Building Services Engineering

Department of Architecture and Civil engineering

CHALMERS UNIVERSITY OF TECHNOLOGY

Göteborg, Sweden, 2019

Direct-Ground cooling systems for Office Buildings: Design and Control Considerations

Taha Arghand

©Taha Arghand, 2019

Licentiatavhandlingar vid Chalmers tekniska högskola

Department of Architecture and Civil Engineering

Division of Building Services Engineering

Chalmers University of Technology

SE-412 96 Gothenburg

Sweden

Telephone + 46 (0)31-7721000

Printed by Chalmers Reproservice

Gothenburg, Sweden 2019

Abstract

Direct-ground cooling systems are defined as systems in which the ground is used as the only source for cooling mainly in commercial buildings. These systems benefit from exchanging heat with the ground, of which its temperature is basically constant below a certain depth year around. Since electricity demand of these systems is only about driving the circulation pumps, the direct-ground cooling systems are among the most environmentally sustainable and energy efficient systems available for cooling buildings.

This thesis is undertaken with a two-fold aim: presenting the design parameters of the ground-coupled systems, and evaluating the methods for controlling the cooling capacity of the direct-ground cooling systems. A comprehensive literature review has been performed on three main design parameters for the ground cooling systems, including ground thermal properties, borehole thermal resistance and building thermal load. All these parameters have been investigated regarding their influence on the energy demand of the system. The literature survey has been further extended to the terminal units operating with high-temperature chilled water, as they are suitable indoor heat terminal units for the direct-ground cooling application. The most common high temperature cooling terminal units have been studied regarding their working temperature levels and cooling capacities.

Control methods for direct-ground cooling systems is the second major aspect studied in the present work. Two control methods, supply temperature control method and flow rate control method, have been applied to a ground-coupled ceiling cooling panel system and a fan-coil unit in laboratory settings. The experiments have been conducted in an office-scaled test room under different thermal indoor climates and heat gains. The results have shown that the design of the control system shall be done in relation to the flow rate limits in the building and ground loops, and the temperature levels of the ground. A high flow rate in the ground loop or in the building loop will not enhance the cooling capacity of the terminal units, but only caused increase in the energy use of the circulation pump. On the other hand, too low flow rate in the building loop increases the condensation risk on the pipes. This is because the supply water temperature in the building loop became closer to the ground temperature which is below the dew point of the space.

Keywords: Direct-ground cooling, High temperature cooling, Ground heat exchanger, Control, Cooling capacity, Fluid temperature levels, Borehole, Laboratory experiments, Optimization.

Preface

The work presented in this thesis has been carried out at the Division of Building Services Engineering, Department of Architecture and Civil Engineering, Chalmers University of Technology. The project was created based on funding by the Swedish Energy Agency (Energimyndigheten) through its national program Effsys Expand.

Foremost, my especial thanks go to my supervisors, Jan-Olof Dalenbäck, Saqib Javed and Anders Trüschel for all their support and input throughout this work. I have learned a great deal from them both professionally and scientifically.

I would like to thank Håkan Larsson not only for his technical assistance in the laboratory, but for all the rich moments full of fun we have had together.

I deeply thank my friends and colleagues of the Division of Building Services Engineering for the great time and help during daily work: Amir, Despoina, Dixin, Jan, Johan, Jonas, Lars, Linda, Maria, Maria, Peter, Sarka and Torbjörn.

Last but not least, I am forever grateful to my parents and sister for all their lifelong support, patience and tolerance.

Gothenburg, 2019

Taha Arghand

List of publications

This thesis is based on the following peer-reviewed publications.

- I. Arghand, T., Javed, S., Trüschel, A., Dalenbäck, J. O. Control methods for a direct-ground cooling system: an experimental study on office cooling with ground-coupled ceiling cooling panels. Submitted to Energy and Buildings (resubmitted with minor revision)
- II. Arghand, T., Dalenbäck, J. O., Trüschel, A., Javed, S. Some aspects of controlling radiant and convective cooling systems. Accepted for publication in Proceeding of the 13th REHVA World Congress, CLIMA 2019. Bucharest, Romania

List of abbreviations

ASHRAE	American Society of Heating, Refrigerating, and Air-Conditioning Engineers
FCU	Fan-Coil Unit
GHE	Ground Heat Exchanger
GSHP	Ground-Source Heat Pump
HEX	Heat Exchanger
HTC	High Temperature Cooling
TABS	Thermally Activated Building System

Contents

Abstract	iii
Preface	v
List of publications	vii
List of abbreviations	ix
1. Introduction	1
1.1. Research objectives	1
1.2. Methodology.....	2
2. Ground-cooling systems	5
2.1. System overview.....	5
2.2. Design of closed-loop ground heat exchangers.....	7
2.2.1. Building thermal load.....	8
2.2.2. Ground thermal properties	9
2.2.3. Borehole thermal resistance	10
2.3. Summary Ground cooling system	14
3. Room terminal units	17
3.1. HTC convective-based terminals.....	18
3.2. HTC radiant-based terminals.....	19
3.2.1. Ceiling cooling panels.....	19
3.2.2. Thermally active building systems (TABS).....	20
3.2.3. Floor heating and cooling systems	20
3.3. Summary Building Terminal units	21
4. Control systems	23
4.1. Introduction	23
4.2. Laboratory setup.....	24
4.2.1. Experimental facility	24
4.2.2. Control setup	27
4.3. Control methods for a ground-coupled ceiling cooling panel system	29
4.3.1. Control methods	29
4.3.2. Sensitivity analysis.....	31
4.4. Radiant and convective terminals.....	33

5. Concluding remarks37

5.1. Main conclusions37

5.2. Future work.....38

References39

1. Introduction

Comfort cooling and heating systems for office buildings typically comprise three main parts: the source, the distribution system and the terminal units. Each part is designed in relation with the other parts targeting to provide acceptable thermal environment and air quality for the occupants using as less energy as possible.

Numerous energy efficient measures have been taken to optimize the energy demand of the buildings' heating and cooling systems. These measures often try to cut down the fossil-originated energy use by utilizing nature-friendly sources to the utmost, and efficiently control and operate the system to minimize the losses in the distribution network. Nevertheless, the efficient design would not be achieved without using terminal units which are compatible with this design type.

GSHPs are among the most commonly used heating technologies in Sweden, mainly for heating of single family buildings. Relatively low Swedish electricity prices and a large share of renewable electricity, together with a high potential of using boreholes in rock, are major drivers of the use of ground-source heat pumps in Sweden. The advantage in comparison to air source heat pumps is a more constant temperature in the ground than of the outdoor air. However, air cooled chillers is the most common cooling technology, while a number of ground and air source heat pumps can also provide cooling by reversing the heat pump.

Alternatively, it is possible to directly connect buildings' cooling systems to the ground. However, the outlet cooling fluid temperature from ground is usually higher than temperature ranges prescribed for operating traditional cooling systems. An established use of boreholes in rock (for heating) together with terminal units designed for high temperature cooling (HTC) facilitates utilizing direct-ground cooling technology in Sweden. However, the design of such system entails knowledge of how the room terminal and the ground interact with each other.

1.1. Research objectives

There is a large body of literature investigating the ground-coupled heat pump systems, heat pumps, ground thermal properties and building thermal performance, for buildings' heating and cooling applications. However, as the ground is the only cooling source in the direct-cooling application, and as direct-ground cooling implies relatively high temperature, the thermal performance of the building terminal units and the ground thermal properties are of major interests in this work.

A key obstacle to the wide-scale implementation of direct-ground cooling systems for office buildings is the lack of knowledge on how would be the thermal interaction between the ground and terminal units in a short-term and long-term perspectives. When a certain terminal device is used for HTC from a direct ground system, a number of factors can influence its thermal

performance. These factors can be generally divided into building-related factors and ground-related factors. How these factors should design and interact to obtain the best possible result in terms of indoor thermal environment and utilization of direct-ground cooling is an intricate question.

This thesis is written with a two-fold aim: first presenting design parameters of ground-coupled systems, and second presenting methods for controlling the cooling capacity of the direct-ground cooling systems.

The thesis aims at introducing the direct-ground cooling systems based on a literature review focused on the design parameters that will be used as the basis for the continuation of this work. Furthermore, the report summarises work carried out to evaluate control methods for ground-coupled terminal units for office buildings utilising chilled ceilings and fan-coils.

1.2. Methodology

Direct-ground cooling systems in an international framework are commonly applied to Thermally Activated Building Systems (TABS), i.e. systems where water with a temperature close to the room temperature is circulated in walls and floors. However, the majority of Swedish cooling systems utilise hydronic cooling system terminals, e.g. chilled beams and fan-coils. Furthermore, the most common type of ground heat exchangers used in Sweden are U-pipes in boreholes in rock. Therefore, the research work is mainly focused on design and performance of direct-ground cooling systems utilising boreholes in rock and hydronic terminals like chilled beams, chilled ceilings and fan-coils. This background report gives, however, a more general overview of technologies where the ground is used for cooling.

This work has a two-fold methodology: literature review and experimental laboratory studies. The work started by a comprehensive literature review of the ground-cooling systems, high-temperature cooling terminal units and their corresponding control methods. The literature review is integrated in Chapter 2 “Ground Cooling Systems” and Chapter 3 “Building Terminal Units”, while Chapter 4 “Control Methods” includes the results from the laboratory experiments. The steps are described in the following, but will be further explained in their associated sections explained in paper appended.

Literature review

The literature review of the ground-cooling systems provides an overview of various types of the available systems for utilizing the ground for cooling in Chapter 2 “Ground Cooling Systems”. Then it goes more in-depth regarding the parameters related to the ground which influence the design and thermal performance of the cooling system. Chapter 2 is followed by chapter 3 “Building Terminal Units” discussing the principle of high-temperature terminal units, as they are used with the ground system for the direct-ground cooling application. This chapter focuses on the

operational characteristics of the terminal units such as cooling capacity, prescribed supply temperature levels, etc.

Laboratory tests

Chapter 4 “Control Methods” outlines the experimental tests carried out in the laboratory. All measurements were performed in the test chamber outfitted and decorated as a single-plan office. Different control methods and controllers were applied for controlling the cooling capacity of the ground-coupled terminals.

2. Ground-cooling systems

Ground features great energy storage characteristics. Measurements show that the ground temperature at a certain depth (below 8- 10 m) is nearly stable all year round [1]. Thus, the temporary and seasonal fluctuations of ambient air temperature hardly causes change in ground temperature, since they are diminished at the shallow depth of the ground. This is due to the large thermal inertia of the ground, which acts as an insulation layer.

Ground temperature changes from one place to another, and it mainly depends on the environmental factors, such as the ground intrinsic thermal and structural properties and the ambient temperature, among others. The average ground temperature in Sweden is approximately 3-10 °C at 100 m depth [2]. The prescribed working water temperature for many HTC applications is within the range of 13- 20 °C. Thus, the ground can be adopted as a cooling source for buildings.

The following chapter includes a brief overview of ground-source cooling systems for building applications followed by a section reviewing the influential parameters to design a ground-source system.

2.1. System overview

Ground energy utilization is performed using ground heat exchangers (GHE). GHEs are made up of pipes or ducts inserted vertically or horizontally in the ground. The fluid inside the GHEs exchanges heat with the ground to cool or heat the fluid in the building loop. GHE systems are classified as open- or closed-loop systems [3].

Open-loop systems inject groundwater from a well to cool down the cooling medium in the building. The groundwater, then, is rejected to another well. In the closed-loop systems, the heat carrier fluid is circulated in an array of pipes inserted in the ground. The heat carrier fluid is usually water or water mixed with some anti-freeze liquid, and it can be directly used as the cooling medium in the building or exchanges heat with the building loop via a heat exchanger. With closed-loop systems, the distinction is made between vertical and horizontal GHEs, Figure 1.

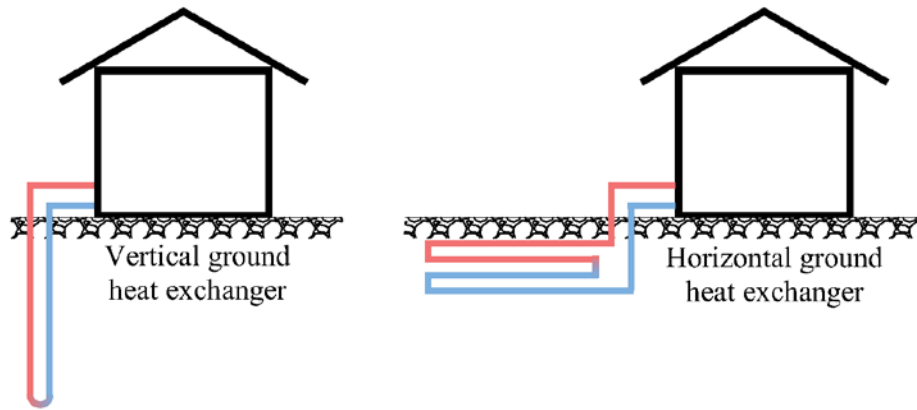

Figure 1. Schematic of horizontal and vertical ground heat exchangers

Horizontal GHEs are usually buried in a shallow depth, and a typical loop of 35- 60 m long is required to provide 1 kW of cooling capacity [4]. This type of GHEs is easy to install, especially during construction of buildings. However, relatively large area is needed for embedding the pipes in the ground. Horizontal GHEs can be installed for small residential applications and soccer field applications, among others.

Alternatively, vertical GHEs can be used in places where high cooling demand should be provided from a smaller ground area. The vertical GHEs are typically 50- 300 m deep, depending on the system design [5]. Vertical GHEs are generally available in two configurations: U-pipes and coaxial pipes, Figure 2. U-pipe GHEs consist of a pair of straight pipes which are connected at bottom by means of a U-turn. The coaxial configuration usually comprises two concentric pipes.

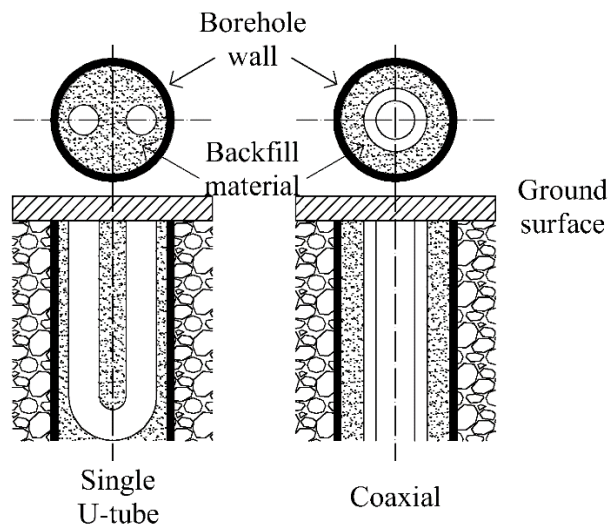

Figure 2. Common vertical ground heat exchanger designs

The use of ground source for cooling buildings falls into two categories: direct-ground cooling and ground-source heat pumps. According to ASHRAE Handbook- HVAC Applications chapter 34 [6], ground-source heat pumps are defined as systems using ground or ground water as a heat sink or source. For cooling applications, ground-source heat pumps use chiller or reversible vapour compression cycle to remove heat from the building and discharge it to the ground by circulating a fluid through the GHEs. Exchanging heat with the precooled fluid instead of warm ambient air increases the energy performance of the heat pump. Ground-source heat pumps are typically used for cooling in places where the ground temperature is not sufficient to provide enough cooling power buildings.

In the closed-loop direct system, however, the fluid in the building cooling system directly exchanging heat with the ground. In this method, there is no refrigeration cycle involved in the cooling process. The fluid in the ground loop is circulated through an array of GHEs and exchanges heat with the building loop via a heat exchanger. The direct-ground cooling is highly energy efficient since the system runs merely with the circulation pump. On the other hand, this system requires a number of boreholes to provide enough cooling capacity for the building cooling system. Drilling the boreholes increases the initial cost. Furthermore, the cooling systems in the direct-ground cooling method operate with small temperature difference with indoor temperature. In this application, terminal units are typically larger in size to provide sufficient area for exchanging heat with the space. In addition, the flow rate in the pipework and the terminal units is larger compared to the traditional cooling systems. Therefore, the initial expenditure on the distribution system and the terminal units is typically higher than that for traditional systems.

2.2. Design of closed-loop ground heat exchangers

Sizing GHE is perhaps one of the most critical aspects of utilizing a ground-source system. The ultimate goal is to size the GHEs in such a way that the overall effect of thermal interaction between building and ground in long term (20- 30 years) does not cause temperature imbalance in the ground. Sizing GHEs is dependent on three key parameters; building heating/cooling thermal demand, ground thermal properties, and borehole thermal resistance. Each of these parameters not only has its own design requirements, but also influences the design and operation of the other parameters. The following section defines crucial terms for designing GHEs and explains how the thermal performances of a ground-source systems benefits from optimum design of these parameters. Figure 3 shows the parameters having major contribution in designing GHEs.

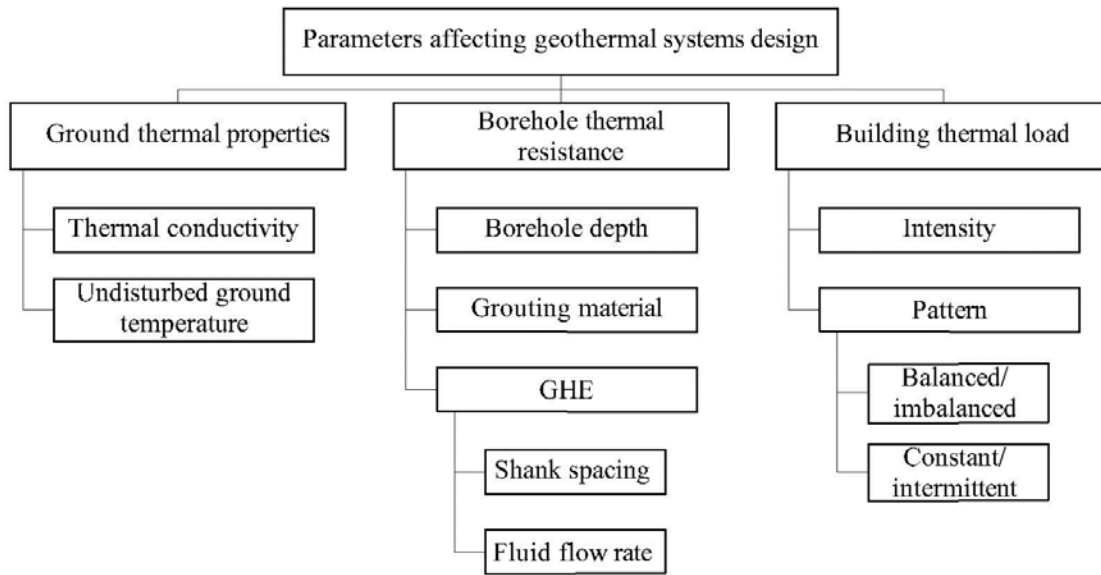

Figure 3. Parameters playing key roles in designing the geothermal systems [7].

2.2.1. Building thermal load

Buildings' thermal loads consists of space and domestic hot water heating loads and space cooling load. Buildings' thermal demand can be partly or wholly obtained by the ground for comfort heating and cooling purposes. To characterize the correlation between building heat load and ground thermal capacity, intensity and pattern of the building's load should be taken into account.

Heat load pattern

Naumov [8] characterized the influence of the building's load pattern by introducing the "load factor" concept. Load factor is defined as the ratio between the net cooling and heating loads of the building to the sum of their absolute values. The value of the load factor varies between -1 and +1. The most favourable design of a ground-connected heating and cooling systems obtains when load factor is close to zero, meaning that there is a balance situation between heating and cooling the ground. The imbalance situation has consequences on the ground undisturbed temperature. In this case, the undisturbed temperature of the ground rises or falls over years to reach a new equilibrium temperature. If the new temperature level of the ground reaches to the desired space temperature, the cooling power of the system reduces in such a way that running the system might not be cost effective any longer. Javed et al. [9] has demonstrated how the borehole system design can be improved by balancing the heat load pattern of a building during the design phase by optimizing the solar heat gain through the building envelope.

The continuous and intermittent load pattern to discharge and charge the ground also affects the ground undisturbed temperature. Gao et al. [10] characterized the influence of the heat load pattern on the ground temperature by three parameters: on-time period, intensity and intermittent interval. Liu et al. [11] noted that intermittent operation of a GSHP restrained the outlet temperature increase

of the GHE compared to continuous operation of the heat pump. Liu et al. [11] and Shang et al. [12] concluded that the recovery time, i.e. time taken for the ground to reach to its initial temperature before charging with heat load, was more influenced by short on-time rather than long off-time for the heat pump.

Heat load intensity

While building heat load pattern defines the long-term performance of GHE, heat load intensity is the term being used for sizing GHEs. Based on the steady-state heat transfer methods, GHE depth is linearly proportional to the building heat transfer rate [13]. In other words, larger heat load needs deeper GHE or more number of GHEs. This issue will be further discussed in section 2.2.3.

2.2.2. Ground thermal properties

Undisturbed ground temperature

Ground temperature gradient is characterized by three zones: Surface zone (from ground surface down to 1m depth), shallow zone (from 1 m to 10 m depth), and deep zone (below 10 m depth). Ground temperature in the deep zone is called “undisturbed ground temperature” and is moderately constant all year round, although it slightly increases with depth in the range of 0.5-3 K per 100 m [14]. The estimated undisturbed ground temperature in Sweden at 100 m depth varies within the range of 3-10 °C, depending on the region [2] .

The undisturbed ground temperature is a decisive value to estimate the available thermal capacity of the ground-connected systems. It is, in fact, the minimum achievable temperature in the ground for cooling applications. Heating or cooling the ground changes its natural temperature. This temperature change is proportional to the difference between the mean fluid in the GHE tubes and the undisturbed ground temperatures. The GHE length varies directly with undisturbed ground temperature. If the ground temperature level approaches the targeted indoor temperature, the primary cost for the ground system, including drilling expenses, increases so that using a ground system would not be cost effective any more. The undisturbed ground temperature is usually determined in large projects by performing on-site experiments and in small projects by applying estimation methods [15,16].

Ground thermal conductivity

Ground thermal conductivity describes the capability of ground to transfer heat and it is generally influenced by two factors: environmental factors and compositional factors. The compositional factors are usually intrinsic properties of the ground, such as mineralogy, particles size, shape, and gradation. Detailed information about the compositional factors for each place can be obtained by analysing ground samples at different depth. The environmental properties of ground include the moisture content of ground and the undisturbed ground temperature. Carrying out the in-situ thermal response test provides details on the ground environmental properties [16].

It is worth noting that the compositional properties are constant over long run and will not be affected by the operating of the ground heating/cooling systems. However, the amount of

environmental parameters could gradually change in long-term due to the change in environment and/or operation of the ground-source system. For instance, a study by Leong et al. [17] showed that alteration of ground saturation could significantly change the thermal performance of the ground system.

2.2.3. Borehole thermal resistance

Borehole thermal resistance is defined as the thermal resistance between the fluid circulating through the U-tube and the ground where the borehole is inserted in. The overall borehole thermal resistance includes the resistances of the heat carrier fluid, GHE pipes, borehole casing, the backfill material and the physical arrangement of the GHE inside the borehole.

This section describes the connection between thermal performance of a borehole in relation to backfill material, fluid flow rate in GHE, shank spacing and borehole depth.

Backfill material

The main task of the backfill material is to facilitate heat transfer from the GHE to the borehole casing. Thus, having low thermal resistance is the main requirement for the backfill materials. However, backfill materials need to fulfil some laboratory characteristics, such as permeability, physical compression strength and workability, to ensure acceptable sealing[18].

There are two types of backfill materials available to fill the annular space between the GHE and the borehole casing: grout and groundwater. The application of groundwater filled boreholes is limited to the places wherein it is legally allowed to use this system and the groundwater level is in the close proximity to the ground surface. The grout usually consists of bentonite, and can be mixed with other additives to increase its thermal conductivity. Thermal conductivity of many commercial grout is within the range of 0.8 to 2.4 W/m.K [18].

It is generally understood that high thermal conductivity of the backfill results in decreasing the thermal resistance of the borehole and increasing the thermal performance of the GHEs. Figure 4 shows that borehole internal resistance decreases with increase in backfill thermal conductivity. However, further increase of thermal conductivity above 1.5 W/m.K would not significantly contribute to reduce the borehole thermal resistance in either of the borehole configurations. This issue is further investigated by Jun et al. [19] and Pouloupatis et al. [20], and it was concluded that the thermal conductivity of the ground acts as insulation if its value is lower than the backfill thermal conductivity.

To sum up, the literature on the grout-filled GHEs recommends to keep the thermal conductivity of the backfill as close as possible to the ground thermal conductivity to obtain the best efficiency [18].

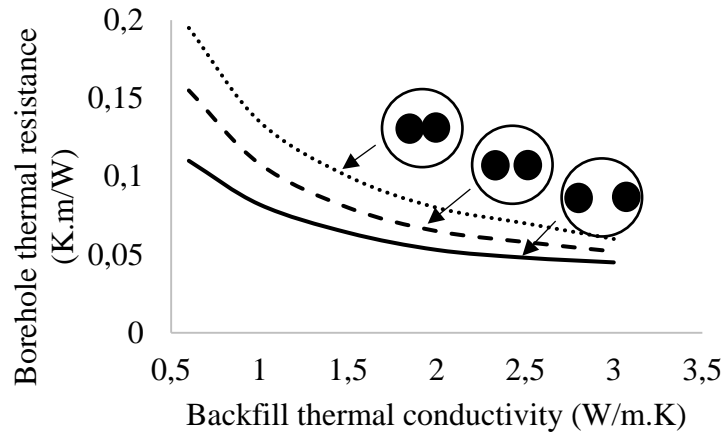

Figure 4. Borehole resistance as a function of the heat conductivity of the filler material and the placement of the u-tube legs in the borehole [2]

In Scandinavian countries, due to geological properties of the ground, the boreholes are allowed to naturally fill with groundwater [21]. In this case, the groundwater lies few meters from the top of the borehole and fills the borehole down to the bottom, where it is encircled by the bedrock. Therefore, there is no need to use backfill materials. The groundwater-filled boreholes benefits mainly from convection heat transfer to exchange heat with the ground, as opposed to conduction method in the grouted-filled boreholes.

The thermal resistance of the groundwater-filled boreholes has found to be generally lower in the fractured bedrock. This is because the groundwater moves through the rock fractures, wherein convective flow reaches the colder groundwater. Mixing of the cold groundwater with the warm convective water causes the borehole resistance to become lower.

The Experiments evaluated the thermal performance of the groundwater-filled boreholes generally focused on the convection flow influenced by temperature differentials and heat injection rates [22,23]. Gustafsson and Westerlund [24], Gustafsson and Gehlin [25], Javed et al. [26], Javed [23] and Spitler et al. [27] showed that increasing the mean fluid temperature and the heat injection rate causes the borehole resistance to decrease, since increasing both parameters intensified the convective flow in the borehole. For fractured bedrock, changing the temperature levels of the water and the heat injection rate may not change the borehole resistance significantly. The convective flow spreads out in the bedrock and the cold water replaces, which makes the borehole resistance unchanged. More details of different methods to calculate the thermal resistance of the groundwater-filled boreholes are described in Javed and Spitler [28].

Fluid flow rate in GHEs

Circulating a thermal fluid carrier through GHEs at different flow rates has been investigated in various studies from the stand point of total extracted heat from the ground and borehole outlet temperature. Han and Yu [29] simulated the influence of fluid flow rate on the heat capacity of a GSHP. The results indicated that increasing the flow rate in GHE provided higher heat capacity for the system. The results also showed that the total extracted heat increased with increasing the flow rate until the turbulent flow pattern developed in the pipe. Further increase of the flow rate of the turbulent flow did not significantly contribute to increase the extracted heat rate. In the same context, Jun et al. [19] and Zhou et al. [30] concluded that the increase in heat exchange rate per GHE depth gradually declined after reaching the turbulent pattern in the pipe. It is also worth noting that too low flow rates in GHE tends to have a reverse effect on the borehole thermal resistance. Javed and Spitler [28] and Beier et al. [31] showed that reducing the flow rate below a certain level caused a dramatic decrease in the thermal resistance of the borehole due to the combined effect of short thermal circuiting between the GHE's legs and low heat transfer rate of the laminar flow.

Although the results agree about the influence of the flow rate on the thermal performances of geothermal systems, there is a large discrepancy in the extent of the reported effectiveness. Table 1 summarizes the heat extracted rate due to the increase in the flow rate. One reason explaining this discrepancy is the effect of borehole length. As explained in [29], longer boreholes benefit from increasing the flow rate more than the shorter ones. Another reason could be the temperature difference between the borehole inlet and outlet fluid. If this temperature difference is small at a given flow rate, increasing the flow rate would make the temperature difference even smaller, which in turn, reduces the thermal capacity of the geothermal system. Therefore, increasing the circulation rate of the borehole fluid should be performed in relation to the geometry of the borehole (length, pipe diameter, U-tube configuration) and the design of the heat pump or the heat exchanger in the building side.

Table 1. Influence of flow rate change on the extracted heat rate from the ground

Flow rate/velocity change	Extracted heat rate change (W/m)	Borehole type	Publication
0.1 to 0.25 l/s	52.8 to 55.6 (+5%)	Single U-tube	[32]
0.75 to 1.11 l/s	134 to 136.1 (+2%)	Single U-tube	[12]
0.3 to 0.9 m/s	35.2 to 39.3 (+12%)	Single U-tube	[19]
0.1 to 0.3 m/s	26.7 to 43.3 (+62%)	Single U-tube	[29]
0.1 to 0.7 m/s	13.6 to 48.2 (+254%)	Single U-tube	
0.1 to 0.7 m/s	20 to 34 (+70%)	Single U-tube	[30]

Shank spacing

Shank spacing is defined as the centre-to-centre distance between the up-hole and down-hole tubes of a GHE. Keeping a certain distance between the shanks of a U-tube GHE is of importance to limit the internal heat exchange (short-circuiting) between the pipes and increase the heat removal rate by the ground, Figure 5. An approximate shank spacing of 50- 70 mm is typical [33].

It is generally accepted that the thermal short-circuiting risk in the boreholes is the consequence of small distance between the U-tubes legs. The lowest thermal resistance of the borehole can be achieved when the pipes touches the borehole wall [20]. However, the influence of shank spacing is also highly dependent on the grout thermal conductivity. Yavuzturk [34] and Jun [19] showed that for a given shank spacing configuration, the thermal conductivity of a borehole with low conductivity grout was significantly lower compared to a highly conductive grout. Casasso and Sethi [35] also confirmed the observations in other studies, but they stated that the shank spacing effect became insignificant when grout thermal conductivity increased. There are many methods for calculating the grout thermal conductivity for borehole with different shank spacing. A comprehensive study by Javed and Spitler [36] evaluated these methods based on their mean absolute and maximum absolute percentage error.

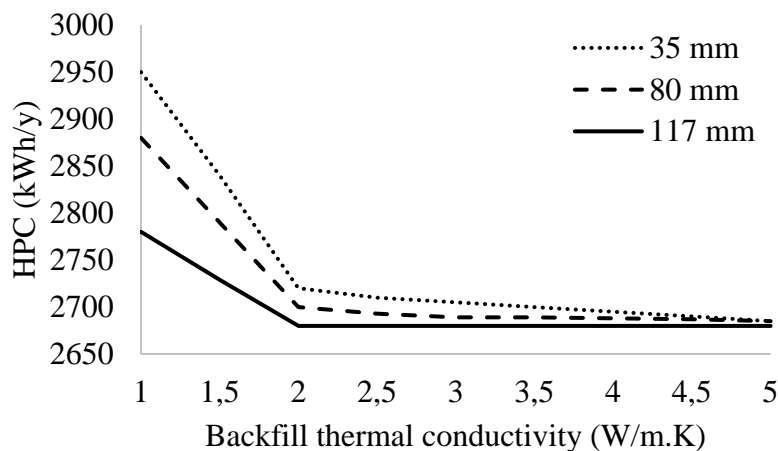

Figure 5. Estimated annual energy demand of the GSHP in relation to shank spacing and backfill conductivity [35]

Borehole depth and diameter

Drilling ground to insert boreholes is costly and there is always a trade-off between the cost and the outcome, i.e. thermal power injected to/extracted from the ground. Borehole depths are typically ranging from 50 to 300 m. Drilling deeper boreholes involves considering the local ground condition, available drilling technology, geothermal power required, etc.

Among several methods available for sizing GHEs, two methods have gained popularity. The first method is developed by Ingersoll and Zoberl [13] and is based on Fourier's law of heat conduction,

include analytical and cylindrical source models. An alternative method is called “g-functions” method and is attributed to Eskilson [37]. Both methods have advantages and limitations and they have been implemented in software tools for simulating and modelling of ground source systems [38].

Generally, the contact area between the fluid and the ground increases as the GHE’s length increases. Therefore, the ground-source system benefits from increasing the borehole length, since the borehole outlet temperature becomes closer to the undisturbed ground temperature and provides higher thermal capacity for the system. However, the increase rate of thermal capacity due to borehole length increase is not constant. Michopoulos and Kyriakis [39] and Casasso and Sethi [35] studied the electricity use of a ground-source heat pump in relation to the total length of the GHE. It was found that the temperature difference between the fluid in the tubes and the ground changes non-linearly as the borehole length increases. Therefore, increasing the borehole length became less significant in increasing the thermal capacity of the ground-source system, Figure 6.

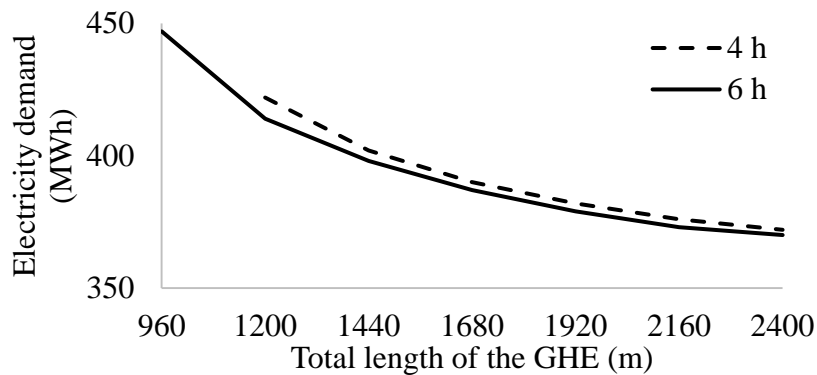

Figure 6. Heat pump electricity demand of a GSHP with multiple boreholes as a function of the overall GHE length. 20 years simulation period, 4- and 8-h time steps [39]

Based on the literature, the borehole outlet temperature is associated with GHE’s depth. However, the effect of depth increase gradually declines, since the fluid temperature gets closer to the ground temperature. From the system thermal performance perspective, designing the optimum length for a vertical GHE requires considering the essential temperature difference the ground needs to provide for the building cooling and heating systems.

2.3. Summary Ground cooling system

Ground cooling system is briefly introduced in this chapter. The parameters playing a role in design of a ground-cooled system in buildings were reviewed and their influence on the energy use and thermal performance of the heating/cooling system were outlined. The literature review on the ground thermal properties focuses on undisturbed ground temperature and ground thermal conductivity, among other factors. Undisturbed ground temperature defines the cooling potential

of the ground. Larger difference between the ground and indoor temperatures provides higher cooling potential by the ground and makes it a cost-effective alternative. Ground thermal conductivity demonstrates the potential of the ground to transfer heat. A greater ground thermal conductivity facilitates removing heat from the GHE and decreases the sizing of the ground-coupled systems.

Building cooling load is highly influential in sizing the cooling system in early stages of design. The cooling load intensity imposes restrictions on sizing the terminal units and the GHE. Excessive cooling load not only hinders the use of high temperature terminal units, but also requires larger GHE to fulfil the cooling demand. Furthermore, heat gain pattern to charge and discharge the ground is found as a prominent factor affecting the ground temperature recovery time and ground temperature change in long term. Imbalance pattern of heating the ground tends to increase the ground initial temperature and limits the cooling potential of the ground in a long run.

Borehole thermal resistance plays a role in the rate of heat transfer between the fluid in the GHE and the ground. The borehole thermal resistance is influenced by the thermal and physical properties of the GHE and the heat carrier fluid, including borehole depth and diameter, shank spacing, fluid flow rate and backfill material, among others. Based on the literature review, improving each parameter helps to decrease the borehole thermal resistance to a certain extent. Further change in that parameter would impose additional cost without any significant outcome.

3. Room terminal units

There are different criteria to classify heating and cooling systems, such as application, response time, media of energy distribution, placement in the room, etc. Considering the type of the thermal carrier type as the reference, systems are divided into water-based (hydronic) and air-based terminal units. While air-based terminals rely on treating the supply temperature and/or flow rate of air to cool or heat the space, water is the thermal carrier in the water-based systems. It is worth mentioning that spaces handled by water-based systems need to be supplemented with ventilation systems to fulfil the requirements of acceptable indoor air quality for the occupants. Thus, only minimum supply air quantity for ventilation is recommended, which has an insignificant role in thermal conditioning of the space [40–42].

However, air does not play an influential role in thermal conditioning of the space in such systems. However, the role of the ventilation system comes down to removing the latent heat and/or maintaining hygienic air quality for the occupants. Thus, only minimum amount of supply air is recommended

Water-based systems can be subdivided into high-temperature and low-temperature systems according to the temperature levels of the water circulated in terminal units. Traditionally in cooling, the terminals are designed to operate at low supply water temperature levels (approximately 6-13 °C) [40]. Keeping the water temperature at such level requires applying refrigeration cycle, which is quite energy demanding. In addition, circulating water at low temperature levels necessitate considering the effect of condensation on the pipes and the manifolds.

Alternatively, high-temperature cooling terminal units utilise water within the temperature range of 14 °C (or above the dew-point temperature of the room) up to just below the room temperature. The main purpose of applying HTC terminals is to reduce the losses in the cooling generation and distribution processes [43]. With respect to cooling sources, using high-temperature chilled water enables the cooling source to reach higher cooling efficiency by reducing the compressor work. In addition, it facilitates the use of environmentally sustainable and low-valued energy sources, such as ambient air, ground, lake/river water, for cooling buildings [44,45].

Major standards and guidelines, including REHVA guideline [46], ASHRAE Handbook on Applications (chapter 54) [6] and Systems and Equipment (chapters 5, 6 and 20) [40], ISO 18566 [47] and ISO 11855 [48], used heat transfer method to distinguish the HTC terminals. Following this classification, HTC terminals fall into two groups: convective- and radiant-based terminals. The most common convective-based terminals are fan-coil units and chilled beams. Radiant-based terminals can mostly be found in three groups: ceiling cooling panels, embedded systems, and thermally active building systems (TABS). Different types of HTC terminals and their operating conditions are further discussed in the following sections.

3.1. HTC convective-based terminals

In convective-based terminals, convection is the primary heat exchange method on the terminal surface. The convection takes place between the room air and the heat exchanger. Chilled beam (active and passive) and fan-coil are two common HTC terminals operating based on convection cooling principle.

Chilled beam is a ceiling-mounted terminal unit manufactured in two types: active chilled beam and passive chilled beam, Figure 7. Whereas passive chilled beam works based on natural convection heat transfer, active chilled beam, which is also called induction diffuser, applies air induction to remove heat from the room. Induction of room air increases the cooling capacity of the active chilled beam [49]. The minimum recommended chilled water supply temperature range for passive chilled beam is 14 °C - 15°C [40] and for active chilled beam is 14 °C - 18 °C [40,50]. The average total sensible cooling capacity of active chilled beam and passive chilled beam is approximately 60- 80 W/ m² and 40- 80 W/ m² per floor area, respectively [51].

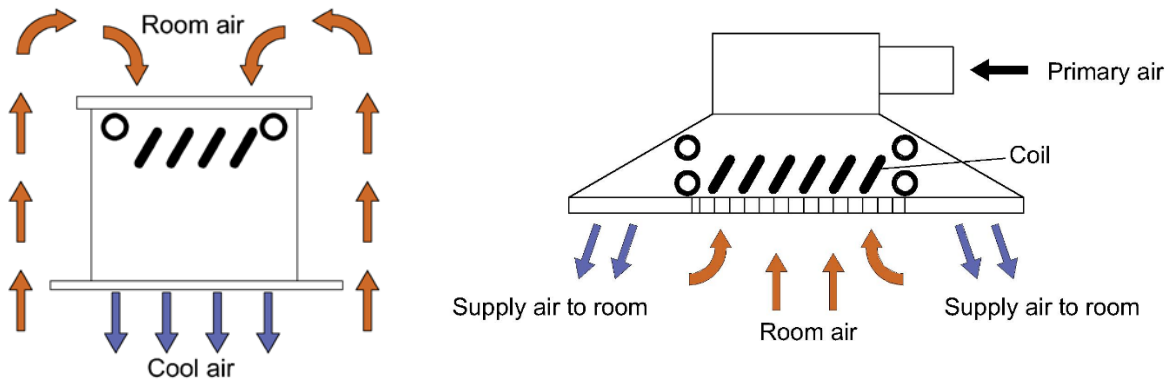

Figure 7. Examples of convective HTC terminals: A) passive chilled beam, and B) active chilled beam [22].

Fan-coil unit consists of a heating/cooling coil and a fan assembled in a common assembly, Figure 8. The air is recirculated through the coil by means of the fan to transfer heat between the media inside the coil to the air. Ordinary operation of fan-coil units involves sensible cooling and dehumidification of the room air. Increasing the supply water temperature above room's air dew-point temperature reduces the cooling capacity of the terminal unit. Thus, using larger units to achieve the same cooling capacity as with conventional terminals is inevitable. More information about this terminal can be found in [52].

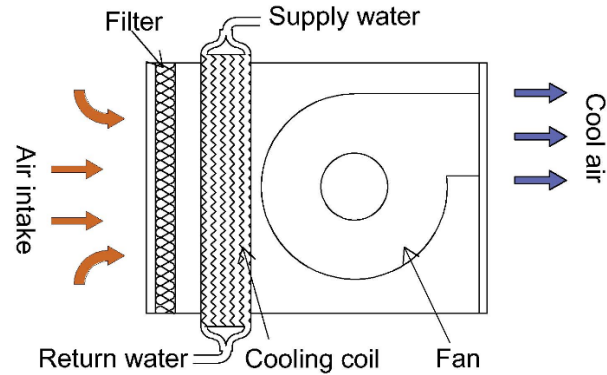

Figure 8. Schematic of a fan-coil unit

3.2. HTC radiant-based terminals

In radiant-based terminal units, majority of heat transfer on the hydronic-cooled surface is performed via radiation [40]. Radiant systems utilise cool surfaces to cool down a space. The primary aim to use radiant systems is to separate the thermal conditioning (sensible) load from the ventilation load to reduce the air flow rate to the minimum possible to fulfil the air quality requirement. The surface area of the terminals is large enough to compensate the small temperature difference between the cooling water and the space.

Hydronic radiant systems are generally classified in three groups, based on their structures: ceiling panels, embedded systems, and TABS [46]. Schematic of these systems are shown in Figure 9. In the following, the most common types of HTC radiant systems are explained.

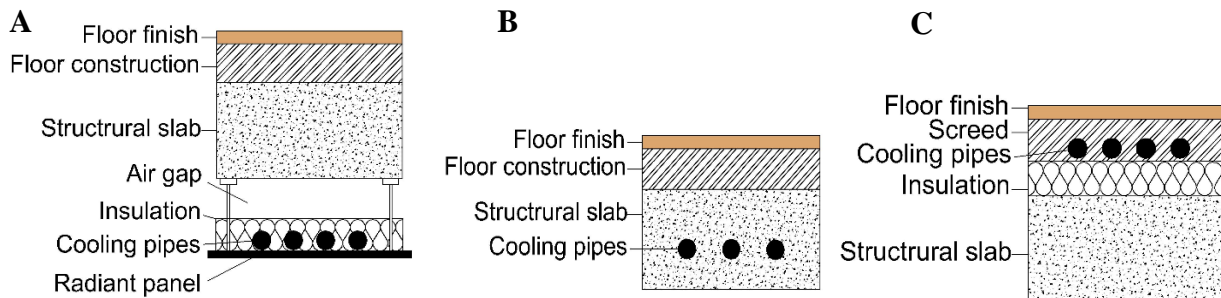

Figure 9. Examples of radiant HTC terminals: A) radiant ceiling panel, B) TABS, and C) radiant embedded surface system [22].

3.2.1. Ceiling cooling panels

Ceiling cooling panels consist of ceiling-mounted water cooled panels made up of hydronic tubes attached to the panel sheets. The panels are usually installed in two variants: free-hanging panels

without insulation and ceiling-mounted panels with topside insulation. Heat transfer in ceiling panels takes place predominantly through radiation, but convection also plays a role. The lower limit of the panels' surface temperature was reported at 14 °C- 15 °C [53,54], but the chilled ceiling surface temperature is usually kept as high as 18 °C - 19 °C to avoid condensation risk. This surface temperature also fulfils thermal comfort conditions for occupants [55]. Cooling ceiling panels can handle up to 100 W/ m² per floor area, depending on the nature of the heat gains and cooling system operating conditions [41].

3.2.2. Thermally active building systems (TABS)

Using pipes embedded in the concrete slabs makes them active components in terms of exchanging heat with surroundings. In fact, TABS benefit from high thermal storage properties of concrete by directly precooling the mass rather than the occupied zone. Due to the small temperature difference between the TABS surface and room air temperature, the cooling capacity of the system is low and it is dependent on the relation between a couple of parameters including inlet water temperature, water circulation duration, supplemented ventilation system, internal heat gains, heat transfer on the room side and on the water side [56]. TABS are capable of handling the sensible heat load in the room up to 50- 60 W/ m², depending on the aforementioned parameters [57–59]. Therefore, TABS are not generally designed to keep the room temperature constant, but to shift the thermal peak load of the room.

3.2.3. Floor heating and cooling systems

In radiant floor or wall systems, high-temperature chilled water is circulated through the pipes embedded in the floor slab to make them involved in the heat exchange process as an actively cooled surface. The active surface is usually separated from the building component by means of an insulation layer. Thus, only some part of thermal mass of the floor or wall is involved in the heat transfer process. The maximum cooling capacity of the floor and wall systems is about 50 W/ m² and 72 W/ m² per floor area, respectively [46]. In places where direct solar beams shines over the floor, the cooling capacity of the floor system significantly increases up to 100 W/ m² [62,63].

The surface temperature is another crucial issue with regard to wall and particularly floor systems. Although the largest cooling capacity is achieved at a surface temperature just above the dew point, comfort issues must also be fulfilled. Typical floor surface temperature reported in the literature was between 18 °C- 23 °C, depending on the floor finish, and occupants' activity level and clothing [64–66]. Nevertheless, lower limit of 19 °C- 20 °C is normally used in office premises [46,63,66].

3.3. Summary Building Terminal units

In this chapter, a review of various room terminal units operating with high-temperature chilled water was carried out. Table 2 summarizes the typical cooling capacity, total heat exchange coefficient and the supply water temperature of various HTC terminals described in this chapter. HTC terminals can be supplied from low-grade renewable energy sources, such as ground. Utilizing high-temperature chilled water also helps to reduce the thermal losses in the pipework. However, it reduces the cooling capacity of the terminals. Thus, HTC terminal units require large surface to exchange heat with the space, which in turn affect their design and control methods.

Table 2. Summary of inlet water temperature, total heat exchange coefficient and total cooling capacity for HTC terminals

Type of cooling system	Average working water temperature (°C)	Total cooling heat exchange coefficient (W/m ² .k)	Total cooling capacity (W/m ² floor)
passive chilled beam	14-15 [40]	-	40-80 [51]
active chilled beam	13-18 [40,50]	-	60-80 [51]
TABS	*	-	50-60 [56,57,59]
chilled ceiling	18-19	11.0-13.2 [55]	100 [51]
wall panels	17 [46]	8.0 [46,67]	70 [46]
floor panels	19-20 [46,65,67]	7.0 [46,67,68]	50 [46]

* Supply water temperature depends on design parameters, surfaces acting, room orientation, operating mode, etc. Further information can be found in [67,69]

4. Control systems

This part summarises the work carried out to evaluate control methods for ground-coupled terminal units for office buildings utilising chilled ceilings and fan-coils. The evaluation is carried out by comparing different control methods in laboratory tests and the result is published in paper I.

The main task of a control system is to maintain the room temperature at the intended range, and also to optimize the energy use of the system. This chapter first reviews the conventional methods to control HTC terminal units. Then, the experimental results about cooling capacity control of the ground-coupled terminal units are presented.

4.1. Introduction

Heat balance of a building is changing due to the outdoor and indoor disturbances. Therefore, thermal capacity of the terminal units needs to be adjusted so that the thermal environment stays comfortable [70]. To fulfil this aim, three main control methods have been applied on hydronic systems: heat flux-modulation, water temperature control, and water flow control [71,72]. The water flow rate in cooling terminals is constant in the heat flux-modulation and temperature control methods, but it is variable in the flow control method.

HTC terminals operate at temperature levels close to room temperature. Therefore, the difference of inlet and outlet water temperatures of the terminal unit is typically smaller than the conventional cooling systems [52]. Small temperature difference requires relatively large flow rate to maintain the cooling capacity of the terminal unit. As investigated by Fahlen [73,74] for convective systems, adjusting the water flow rate had insignificant effect on the cooling performance of the terminal unit, unless it was subjected to large changes. In this case, two-position on-off control method was found superior to the modulating control methods.

Applying flow control method was also tested on some low-mass radiant heating and cooling systems such as floor and wall systems. Cho and Zaheer-uddin [75] applied flow control with on-off and modulating controllers on a floor cooling and heating system. Due to the sophisticated setup and difficulties in regulating small water flow rates with modulating controls, the on-off controller was suggested to control the floor slab.

As opposed to control the flow rate, Adelman [76] suggested to control the supply temperature as an accurate method to control the thermal capacity of radiant terminal units. Ryu et al. [71] and Lim et al. [72] evaluated the application of flow rate control and supply temperature control on floor cooling slab. They reported that linear correlation between changes in supply water temperature and heat output of the terminal facilitated controlling the floor surface temperature, thus resulting in more stable room temperature than with the flow control.

It is worth noting that the cooling capacity of the radiant cooling terminal units is, to some extent, “self-regulating”. Due to the small temperature difference between the fluid and the space, the cooling capacity of the radiant terminals is highly dependent on the room temperature. The self-regulating effect is an inherent characteristic of the radiant cooling terminals and allows the heat transfer rate from the active surface to vary with changes of air and other non-active surface temperatures. The self-regulating effect supports the control equipment to stabilize room temperature variations to a certain extent [52,77]. Although self-regulating effect is more dominant in the radiant terminal units, large active chilled beams supplied with chilled water close to room temperature present the self-regulating effect. Gräslund [78] presented a design method using self-regulating chilled beams with no individual room thermostats to control the indoor temperature within the comfort prescribed range.

4.2. Laboratory setup

Laboratory tests have been the core of this research study. All the tests have been conducted at heating, cooling and air-conditioning laboratory at Chalmers Technical University. The laboratory provides experimental facilities to test a range of different air/water-borne heating and cooling systems. This section describes essential features of the test facilities, including GHE, test room, room terminal units, control systems, which have been used for running the experiments. Further information about the test facilities can be found in papers I and II.

4.2.1. Experimental facility

The experiments were carried out in a mock-up of an office room with the dimension of 4.2 m × 3.0 m × 2.4 m (L× W× H). The room was located inside a large lab-hall and was protected against outdoor temperature variations and sun exposure. The walls were made up of polystyrene panels with the finish of gypsum board from inside. The ceiling comprised compressed glass wool panels insulated by an extra layer of glass wool.

Basic internal heat sources in the test room included electrical lights, a thermal dummy and electrical heating foils, Figure 10. The heat foils on a wall and floor were used to simulate the effect of solar heating in the test room. The heating power of the foils was adjustable based on the heat gain needed in the room.

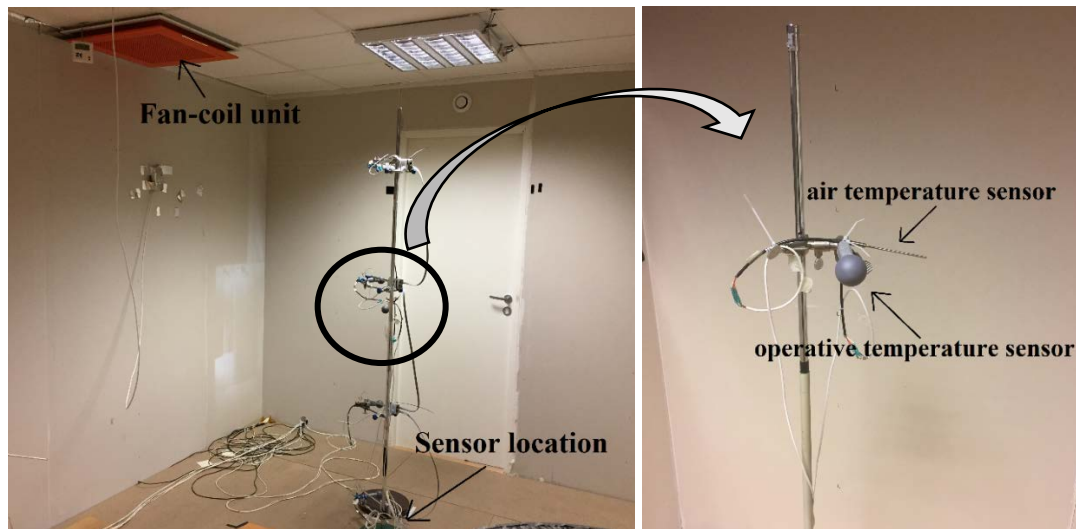
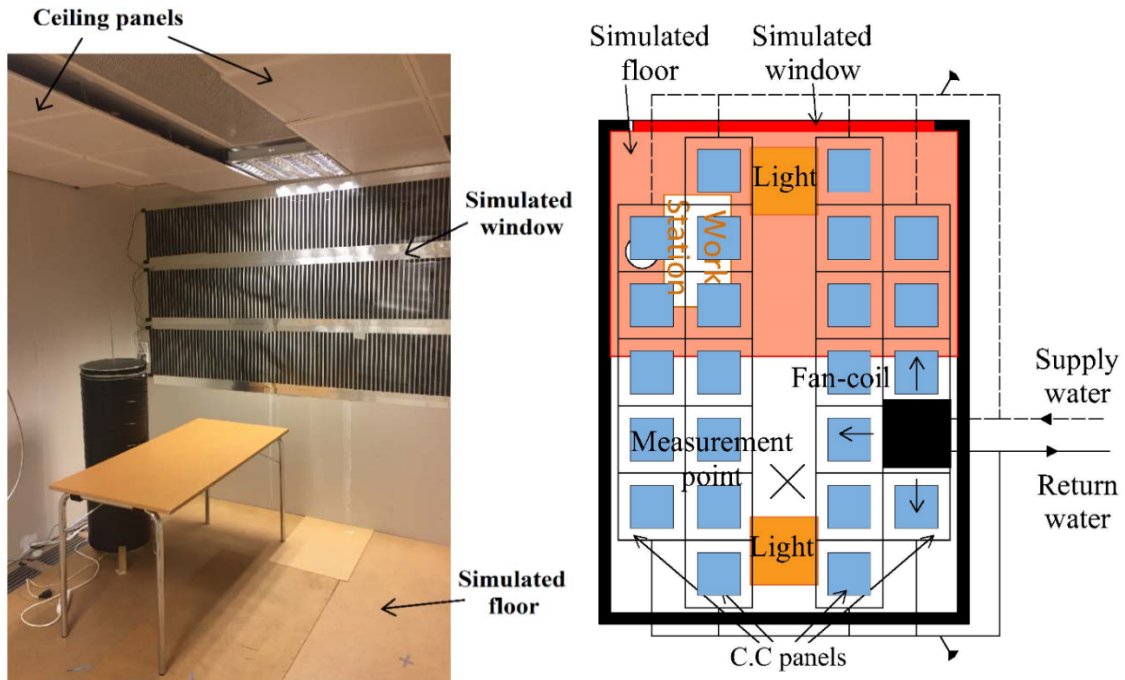

Figure 10. Test room and the layout of the cooling terminals and heat sources as well as temperature sensor's location in the test room

There were two cooling systems installed in the test room: A fan-coil unit (FCU) and ceiling cooling panels. The cassette-type ceiling-mounted FCU included a ground-water cooled coil, and a variable speed fan, Figure 11.

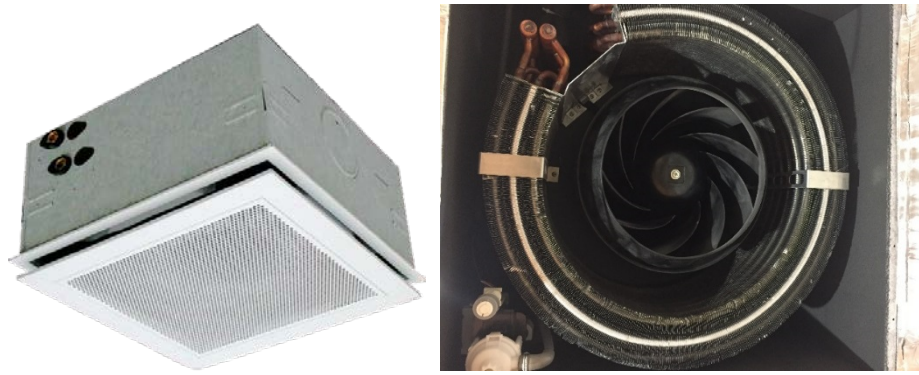

Figure 11. Ceiling-mounted FCU [79], coil configuration and the use of FCU in the test room

The ceiling cooling panel system consisted of 60×60 panels hung 0.2 m below the main test room ceiling. The panels covered approximately 70% of the ceiling area. The panels were made up of copper pipes attached to the surface of the panels and embedded in layer of graphite with topside insulation, Figure 12.

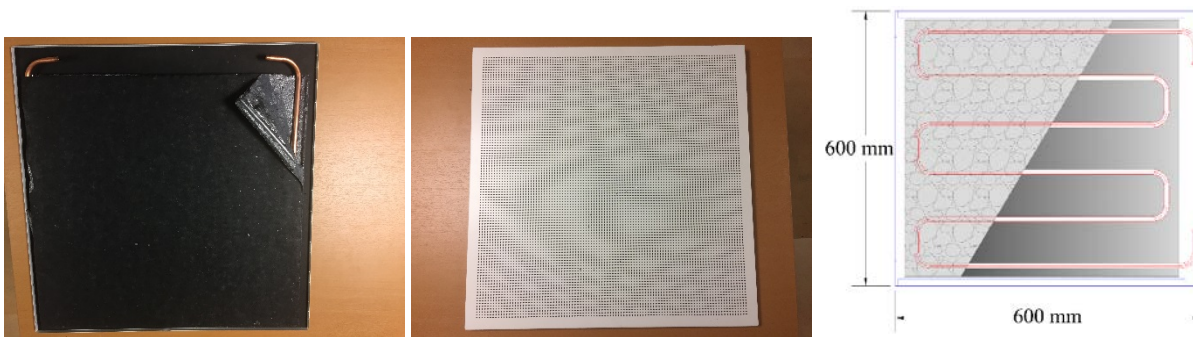

Figure 12. A ceiling cooling panel: back view, front view, and the piping layout

The ground-cooling system was connected to a single U-tube GHE for cooling the water, Figure 13. The GHE was 80 m deep and was drilled in the close proximity to the test room. The U-tube was a polyethylene pipe with inner and outer diameters of 35.4 mm and 40.0 mm, respectively, and was enclosed by a steel pipe as the casing. The borehole was groundwater-filled, as a common practice in Sweden.

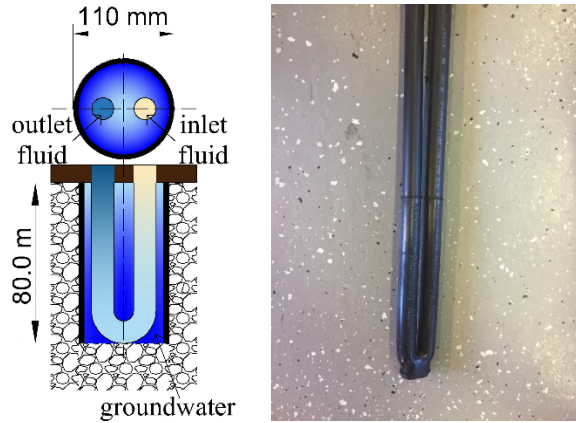

Figure 13. Cross section and schematic views, and the view of the bottom part of the groundwater-filled borehole used for the experiments

The pipework comprised three loops: ground loop, intermediate loop and building loop, Figure 14. The water was circulated through the GHE in the ground loop, and it exchanged heat with the intermediate loop via a heat exchanger. The flow rate in the ground loop was constant as long as the mixing valve position was unchanged. The flow rate in the other loops could be either variable or constant, depending on the control method.

4.2.2. Control setup

A feedback control was used to maintain the room air/operative temperature at the set point. Room temperature was measured using air/operative thermometer at the measurement point at the height of 1.10 m above the floor, Figure 10. The control error, which is defined as the difference between the measured room temperature and the set point, was fed to the controller to change the opening of the control valve and/or adjust the speed of the variable-speed pump in either the building loop or the intermediate loop. Figure 14 shows the schematic of the control system. The control system is explained in detail in paper I.

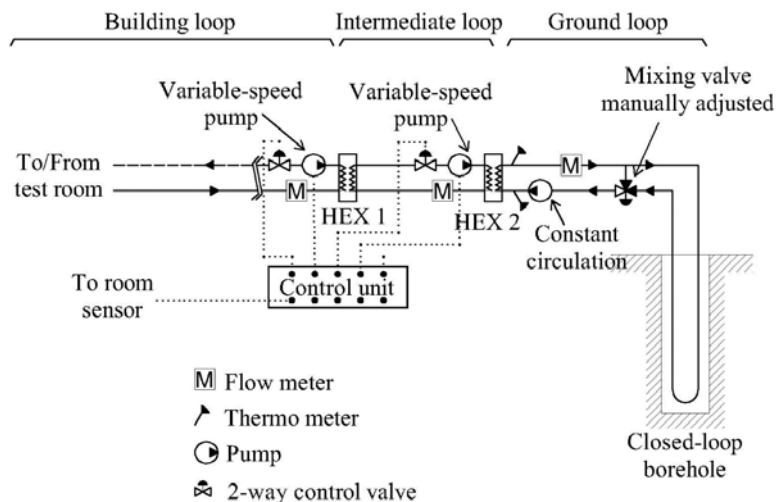

Figure 14. Schematic of the pipework and the control system

Cooling capacity of the terminals could be adjusted with two control methods: supply water temperature control method or supply flow rate control method. These methods were based on changing the flow rate in either the building loop or the intermediate loop, respectively, while the flow rate in the other loop was constant. In this study, changing the flow rate was performed using both the two-way control valve and the circulation pump. The important note to mention is that the fluid flow rate in the ground loop was kept unchanged in both methods.

Two controller types were adopted to control the pump speed and the valve opening: two-state on/off controller and the modulating P controller. On/off control is the most basic form of feedback control which runs the valve or pump in the intermittent mode. Thus, the flow rate is either zero or maximum. The flow rate controlled with the modulating control is continuous but it varies based on the cooling capacity required. In other words, the valve opening or pump circulation speed changes depending on the difference between the actual room temperature and the set-point.

The schematic of the flow control method is shown in Figure 15. In the flow rate control method, the flow rate of the fluid circulating through the terminal unit changes while the flow rate in the intermediate loop is constant. With the two-state on/off controller, the water flow rate in the terminal intermittently changes between zero and the maximum flow rate. The alternative is that the water flow rate varies within the zero and maximum flow rates to provide sufficient cooling capacity for the terminal unit.

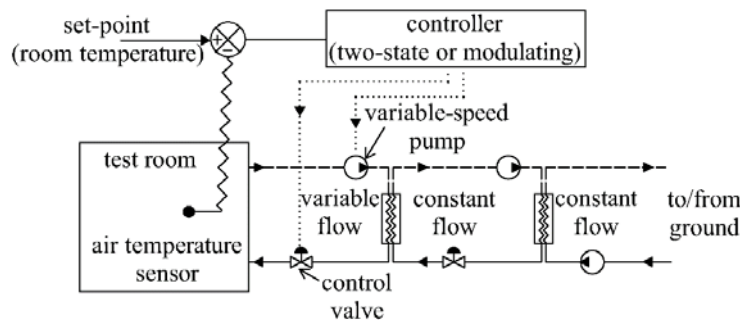

Figure 15. Schematic of the flow control method

Figure 16 shows the overview of the temperature control method. In the temperature control method, the flow rate of the fluid circulating through the intermediate loop changes while the flow rate in the terminal loop is constant. Thus, changing the flow rate in the intermediate loop changes the supply water temperature in the building loop. The flow rate in the intermediate loop can be either intermittent (at zero or maximum flow rate) with the on/off controller, or variable within zero to maximum flow rate with the modulating controller.

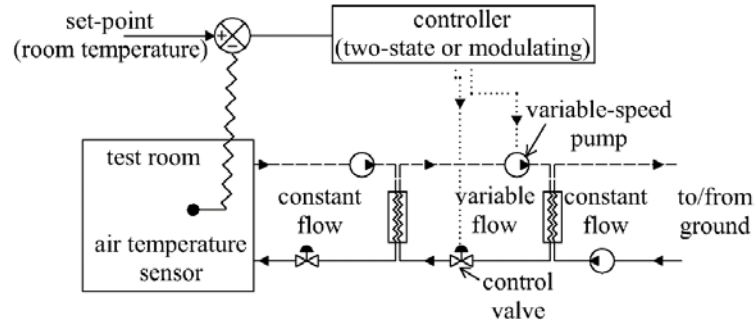

Figure 16. Schematic of the temperature control method

4.3. Ceiling cooling panel system

This section briefs on the outcomes of the laboratory experiments related to the control systems for ceiling cooling panels. More results and detailed discussions can be found in paper I.

4.3.1. Control methods

Two control methods (flow control and supply temperature control) and three controllers (a P controller and two-state on/off controller with and without a deadband) were applied to a ground-coupled ceiling cooling panel system to keep the room temperature at the set-point of 25.0 °C. The high and low heat gains were 700 W (55 W/m²) and 200 W (16 W/m²), respectively. The heat gain intensity changed every 120 minutes.

The time-averaged room air temperature was approximately 25.0± 0.1 °C for all cases for the period of 8 hours under the periodic heat gain condition. However, applying the temperature control method decreased the mean absolute error between the actual temperature and the set-point. The constant circulation of water provided uniform temperature over the whole ceiling, as also observed in [80], resulted in a decrease of room temperature oscillation amplitude. Small temperature difference between the supply and return water and also the self-regulating effect contributed to achieve uniform temperature distribution over the ceiling. This will be further discussed in the following section about the water temperature levels in the ceiling panels.

Applying the two-state controllers with either of the control methods resulted in an oscillating saw-tooth shaped error between the set point and the actual room temperature, Figure 17. The oscillations range was ±0.3 °C for on-off controller and ±0.6 °C for on-off with a deadband controller. Applying the P controller limited the oscillation range of the room temperature to ±0.1 °C, which was not significant compared to when on-off controller was in operation. Based on the room temperature pattern in Figure 17, as long as controlling the room temperature is the main concern, using a two-state controller is suggested, due to its low price and less complication. However, the controller type influences the water temperature levels, which will be discussed in the following.

Based on the results, both control methods along with the controllers were capable to keep the room temperature in the targeted range under periodic internal heat gains. However, the room temperature oscillations were moderately lower when the supply temperature control was in operation.

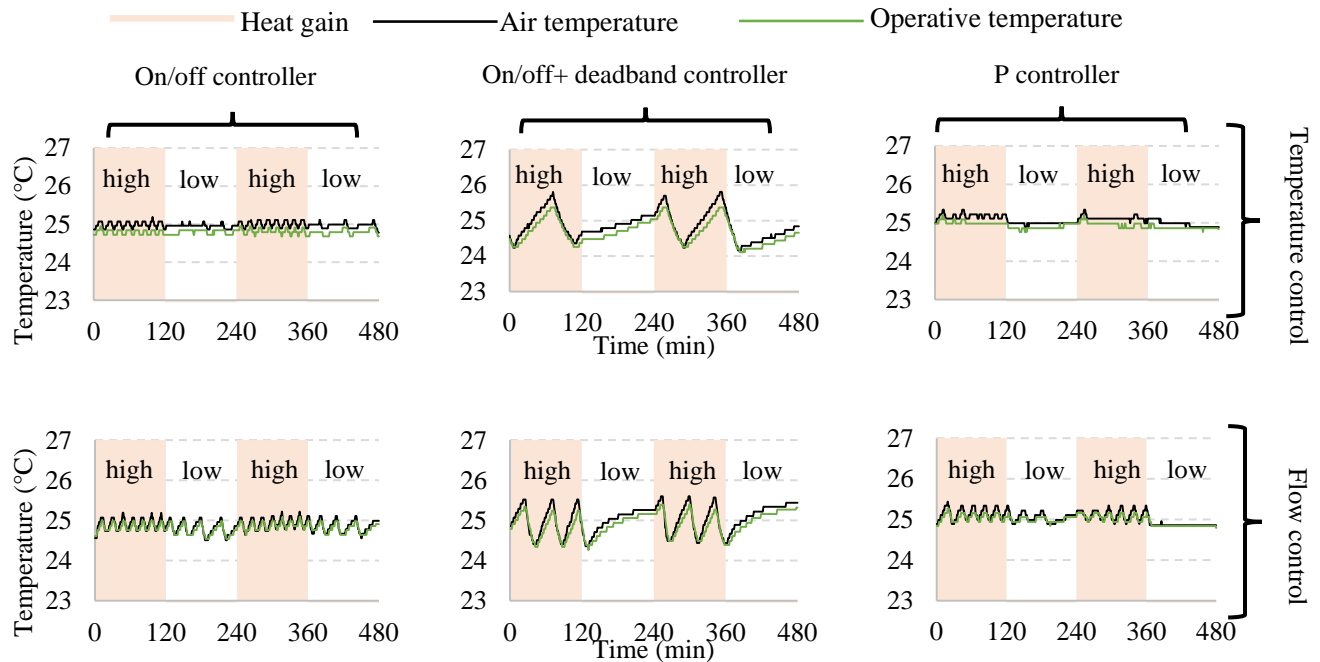

Figure 17. Room air and operative temperatures with water temperature (top) and water flow control (bottom) methods regulated by different controllers

Experiments on the direct-ground cooling system showed that the outlet (leaving from the borehole) water temperature of the borehole was constant at 10.9 ± 0.2 °C for all control systems. However, the water temperature in the building loop and intermediate loop was highly dependent on the control method as well as the controller type.

The supply temperature control method was based on adjusting the water flow rate in the intermediate loop. The water flow rate was constant at the maximum rate in the building loop, while the water flow rate was variable in the intermediate loop. Thus, circulation rate of the water in the building loop was faster than that in the intermediate loop. Consequently, the average water temperature level was high and the difference between supply and return water temperatures was small compared to the cases operated with the flow control method.

Comparing the water temperature levels of the ceiling panels with two control systems is of interest for several reasons. First, the average water temperature of the panels is higher and hence, it is closer to the room temperature, Figure 18. This small temperature difference between the water and room temperature enhances the self-regulating effect for the panels, resulting in more stable thermal environment in the space [77]. Second, the water to the panels is supplied from one side of the room and collected from the opposite side, Figure 10. Small temperature difference between

supply and return water provides more uniform surface temperature all over the ceiling and improves the stability of room temperature. Third, the supply water temperature analysis showed that the risk of condensation on the pipes is more likely with the flow control method. The condensation risk is further aggravated if we apply the P controller. Therefore, designing the control system in relation to the capacity of the heat exchanger and the available temperature level of the ground is of crucial importance to avoid condensation.

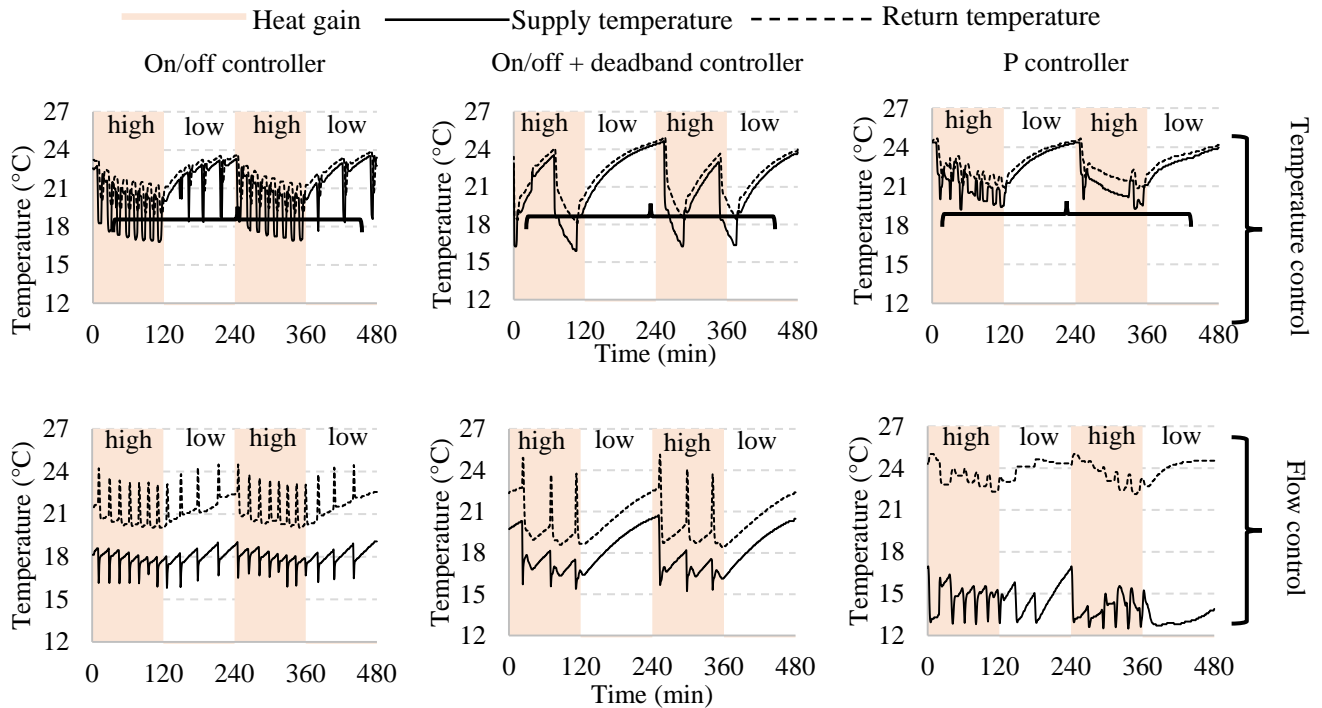

Figure 18. Supply and return water temperatures in the panels with two control methods as implemented by different controllers. The water flow rate in the panels was constant with the temperature control method and was variable (with P controller) or intermittent (with two-state controllers) with the flow control method.

4.3.2. Sensitivity analysis

This section contains the results of a sensitivity analysis on two control parameters: the borehole outlet water temperature levels and the flow rate limits in the building and intermediate loops. These parameters are evaluated in relation to the cooling capacity of the panels and the energy demand of the circulation pumps. Choice of these control parameters was based on the assumption that to transport a given amount of heat, the operation time of the pump changes as the function of the fluid temperature and flow rate limits. This may also influence the cooling power of the panels, since the flow rate in the building loop influences the panels' surface temperature, as shown in section 4.4.2.

In this section the influence of changing the borehole outlet temperature on pump energy use and panels' cooling capacity was investigated. Furthermore, the energy use of the circulation pumps and the mean water temperature difference (ΔT_m) were studied in relation to the on-state (maximum) flow rate limit of the pumps. ΔT_m is defined as the logarithmically determined average difference between the temperature of the cooling coil and the room operative temperature and represents the cooling power of the panels, as denoted in [81,82].

The parametric study on the pumps' flow rate was carried out under the periodic heat gains for 8 hours, similar to section 4.4.2. Only on/off controller was used to operate the circulation pump and the control valve in the building loop or intermediate loop. For the flow control method (the circulation pump in the building loop), four on-state flow rates of 4.8, 3.5, 2.1 and 1.1 l/min were tested. The on-state flow rates for the temperature control method (the circulation pump in the intermediate loop) were 11.5, 8.3, 5.1 and 3.0 l/min.

Figure 19 shows that increasing the on-state flow rate limits of the pumps in the building loop and the intermediate loop did not significantly change the ΔT_m , while it caused the pump energy use to increase remarkably. In fact, increasing the flow rate did not significantly contribute to increase the heat exchange rate in HEX 1, Figure 14. Thus, the cooling panels' surface temperature remained relatively unchanged at different on-state flow rate limits. On the other hand, since the pump power is generally proportional to the cube (x^3) of the pump speed, the pump energy use increased as the flow rate limits rose.

It can be concluded that the flow rate range for two-state controllers should be designed in relation to the thermal capacity of the heat exchanger and the actual demand of the panels. Further increase of the maximum flow rate limit might help to get higher cooling power in the terminal unit, but it may not be an energy-efficient alternative.

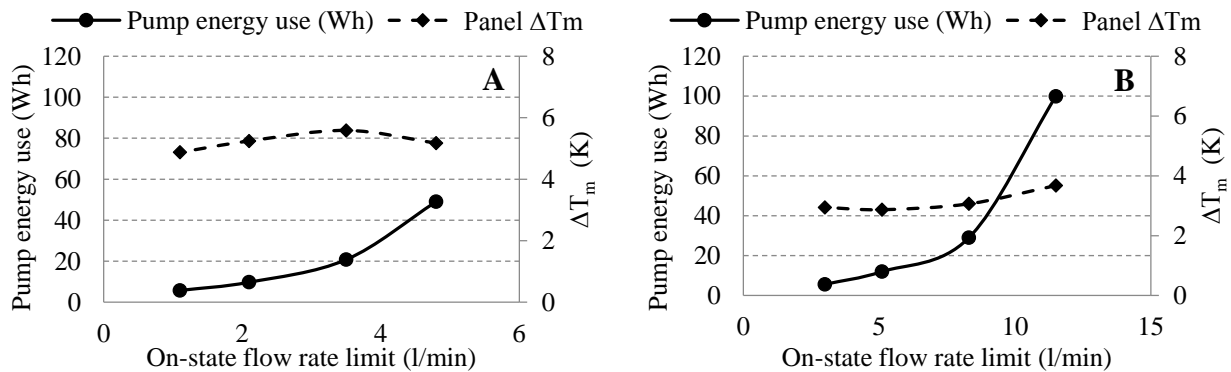

Figure 19. Relation of maximum flow rate with on/off controller, ΔT_m of the panels and energy use of the pump installed in A) building loop and B) intermediate loop. The energy use was measured for a period of 8 hours and tested under periodic space heat gain.

As explained previously in section 4.2, supply temperature control has been presented as an alternative to the flow control method for adjusting the cooling capacity of terminal units. By

increasing the borehole outlet temperature, the corresponding effect on pump energy use in the building loop, ΔT_m of the panels and the correlation between these three parameters was studied. The outlet water temperature steps were 11.9 °C, 13.6 °C and 15.5 °C. The control setup was similar to Figure 16A.

Figure 19 shows changes in the pump energy demand and ΔT_m of the ceiling panels in relation to the borehole water temperature increase. As expected, pump energy use progressively increased with the increase in the outlet borehole temperature, to keep the total amount of the extracted heat from the room constant. For one-fold (about 1.7 °C) increase in the borehole outlet temperature, pump energy use increased by about 74%, while ΔT_m decreased by only 9%. In interpreting this result within the design context we should consider the faster increase rate of the pump energy use compared to the small reduction of panels' cooling capacity when we change the design water temperature of the system.

From the control standpoint, ΔT_m linearly changed with water temperature, representing a straight forward method of adjusting the cooling capacity of the ceiling panels. The control system obviously benefits from applying a method with a linear correlation between the variable parameter (ΔT_m) and the controlled parameter (water temperature), as opposed to a non-linear correlation between these parameters in the flow control method, Figure 19.

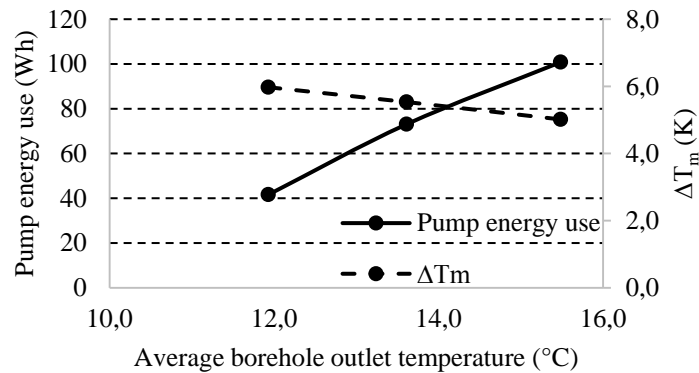

Figure 20. Relation of the borehole water temperature, the ΔT_m of the panels and the energy use of the pump installed in the building loop for a period of 8 hours and tested under periodic space heat gain conditions

4.4. Radiant and convective terminals

This section explains the results in paper II, where room temperature dynamics with convective- and radiant-based terminals were studied.

Room time constant can be defined as the time taken for the room air/operative temperature to reach 63.2% of its final temperature after applying a step change into the room heat gain intensity. Analysing the room temperature during the transient condition until it settles down is crucial to design a control system for the cooling system. Specifically, defining the response type of the

system, e.g. first-order, second-order, etc. facilitates the design of the controllers. For first-order systems, the controller can be designed using the time constant. Designing controllers for systems which do not behave as a first-order system requires analysis of their dynamic behaviour under different thermal conditions.

Figure 20 shows the net increase in the room air and operative temperatures to a step increase in the room heat gain. The net increase is defined as the temperature difference between the initial room temperature before changing the heat gain and its instantaneous value at a given time. The room temperature with both cooling systems followed natural logarithmic trend. Thus, the response type can be characterized as a first order system. It is important to note that the room time constant includes the time constant of the room thermal mass, the terminal unit, the pipework, and the control valve. However, since the time constant of the room thermal mass played the dominant role, its influence was majorly reflected in the overall time constant of the system.

According to Figure 21, the time constant of the room for cooling panels and FCU systems can be calculated as 200 min and 226 min, respectively. Longer time constant obtained with FCU indicates that room temperature changes moderately slower than when the ceiling panels were in operation. Interpreting this result in the control context, the proportional gain of a controller designed for one terminal unit would not be similar for the other one.

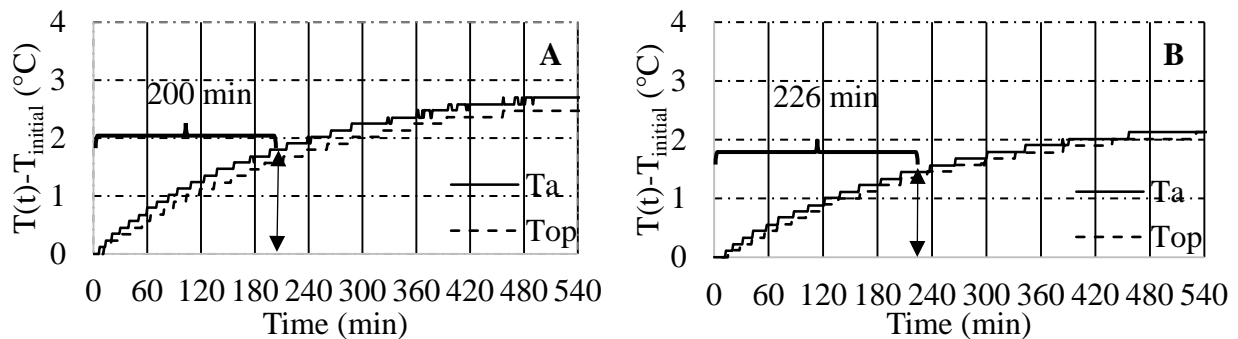

Figure 21. Net rise in air and operative temperatures as the response to the step increase in internal heat gain of the test room cooled by A) ceiling panels, and B) FCU

According to the findings from the step response test, using controller inputs tuned for a convective-based terminal would not be a very accurate controller input for a radiant-based terminal, and vice versa. This assumption was examined by adopting a controller to the FCU which had been originally developed for the ceiling panels. The controller type was proportional (P) controller. Figure 22 shows the air and operative temperatures in the room where a P controller was applied to maintain the room air temperature at 25.0 °C with the ceiling panel system or FCU. The hysteresis gap, i.e. the difference between the maximum and minimum air temperatures, was 0.4 K when the ceiling panels was in operation. The hysteresis gap was increased to 0.8 K when it was adopted to the FCU. The influence of several parameters, including different transfer functions of the room with FCU and ceiling panels, led to different hysteresis gap.

In practice, in situ tuning is needed to minimize the oscillating amplitude, since predicting the thermal behaviour of the system is very difficult.

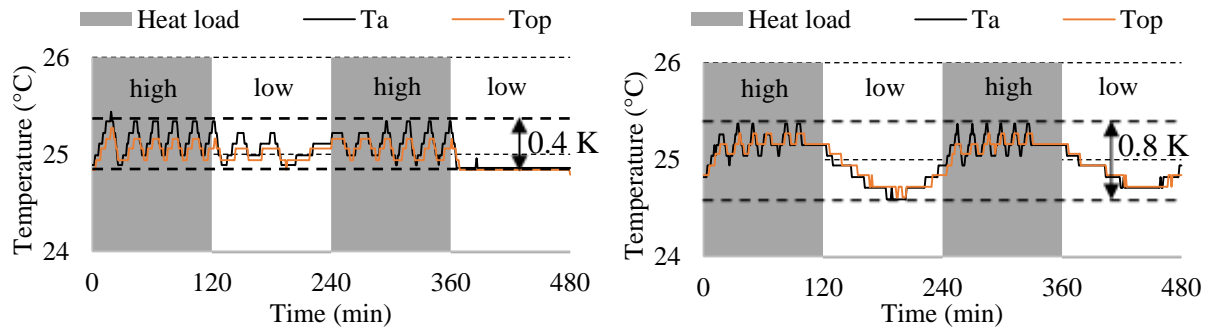

Figure 22. Comparison of air (T_a) and operative (T_{op}) temperature between A) ceiling panels, and B) FCU system tests. Similar proportional gain for P controller was used for both cooling systems to adjust the flow rate to control the room temperature. The proportional gain was tuned only for ceiling panels. The set-point was 25 °C for air temperature.

5. Concluding remarks

The design considerations for ground-coupled cooling systems is not quite similar to the traditional cooling systems using refrigeration cycle. The main difference is the restrictions in the available cooling power from the source and the temperature levels of the heat carrier fluid in the building terminal units. Advances in constructing energy efficient premises and development of terminal units alleviate the difficulties of the wide spread use of direct ground-coupled cooling systems. There is still a lot left to be done.

5.1. Main conclusions

Each chapter in this work has an independent structure from the other chapters with its own discussion/summary. The following are the major conclusions of each chapter:

- The minimum supply water temperature range for the HTC terminal units investigated in this study are between 13- 20 °C. This temperature range is quite compatible with the ground temperature in Sweden (3 to 10 °C at typical depth of 100 m). Thus, direct-ground cooling method can be applicable in many parts of Sweden. However, minimizing the building's cooling demand at the early design stages is of central importance. High cooling demand limits the choice of terminal units. It also requires larger GHEs which imposes financial and sometimes technical restrictions for drilling the GHEs.
- Ground thermal properties, borehole thermal resistance and building thermal load are the essential design factors playing crucial role in the design of direct ground-cooling systems. Ground thermal properties are the intrinsic thermal characteristics of the ground which define the available cooling power of the source. The larger the temperature difference between the ground and indoor, the greater the cooling potential available. Building thermal load is identified by its intensity and pattern and it determines the size, feasibility, and the thermal performance of the cooling system in the short and long terms. Direct-ground cooling system can be regarded as a cost-effective and energy-effective alternative if the building thermal load matches the ground cooling capacity.
- From the indoor temperature control standpoint, practicing both control methods (temperature control method and flow rate control method) with ceiling cooling panels yielded the same outcome. However, the temperature control method offers better cooling capacity control of the terminal unit, lower risk of condensation, and more uniform temperature distribution over the cooling panels. In addition, the role of the controller type (modulating or two-state) for the ground-cooling terminal units is found important regarding the flow control precision during the part-load periods. Having a low flow rate in the panels regulated by the modulating controller is difficult to control precisely and it causes condensation on the panels. Furthermore, the pump energy demand is not necessarily associated with the controller type. Pump energy use with a two-state controller can be

similar to that with a modulating controller, if the water flow rate limits is properly designed for the cooling system.

5.2. Future work

In the present work the fundamentals of direct-ground cooling systems for buildings has been explained. The continuation of this work will be about defining a framework for the design of the direct-ground cooling systems for office buildings. Based on the discussions in chapters 2 and 3, three major parameters are involved in the design of a direct-ground cooling system: building-related factors (terminal units, heat load intensity and pattern, set-point, etc.), borehole thermal resistance, and ground thermal properties. The framework is outlined as the follows:

- Laboratory tests: further experiments on the direct ground-coupled cooling terminals, active chilled beam and ceiling cooling panels in particular, regarding the sufficient temperature levels of the supply fluid. The experiments include investigating the influence of various test conditions, such as room temperature set-point, heat gain pattern and intensity, etc., on the thermal performance of the terminal unit and the GHE.
- Simulation: this part includes developing small-scale models based on the data obtained from the laboratory studies and simulation of the thermal behaviour of the ground in short-term and long-term period. The outcomes will be applied to real-scale models to make feasibility studies and energy analysis for different case studies.
- Documentation: documenting the variety of designs and control approaches for designing ground cooling systems which are commonly practiced by engineers in Sweden. The outcomes of this step will be used to identify areas where research is needed and also to customize the design and control approaches for the direct-ground cooling application.
- Combining the outcomes of the previous steps to establish the design methods for various conditions of the ground, climate, and terminal units for the direct-ground cooling systems in Sweden.

References

- [1] C.O. Popiel, J. Wojtkowiak, B. Biernacka, Measurements of temperature distribution in ground, *Exp. Therm. Fluid Sci.* 25 (2001) 301–309.
- [2] B. ROSÉN, A. GABRIELSSON, J.A.N. FALLSVIK, G. HELLSTRÖM, G. NILSSON, System för värme och kyla ur mark - En nulägesbeskrivning, Statens geotekniska institut (SGI), 2001.
- [3] B. Sanner, *Shallow geothermal energy*, (2001).
- [4] G. Florides, S. Kalogirou, Ground heat exchangers—A review of systems, models and applications, *Renew. Energy.* 32 (2007) 2461–2478. doi:10.1016/j.renene.2006.12.014.
- [5] D. Pahud, B. Matthey, Comparison of the thermal performance of double U-pipe borehole heat exchangers measured in situ, *Energy Build.* 33 (2001) 503–507.
- [6] ASHRAE, *ASHRAE Handbook - HVAC Applications*, Am. Soc. Heating, Refrig. Air Cond. Eng. Atlanta. (2015).
- [7] L. Aresti, P. Christodoulides, A review of the design aspects of ground heat exchangers, *Renew. Sustain. Energy Rev.* 92 (2018) 757–773. doi:10.1016/j.rser.2018.04.053.
- [8] J. Naumov, *Optimization of ground-coupled systems for heating and cooling of buildings*, (2005).
- [9] ASHRAE, *Geothermal Energy, Applications*. (2015).
- [10] Q. Gao, M. Li, M. Yu, Experiment and simulation of temperature characteristics of intermittently-controlled ground heat exchanges, *Renew. Energy.* 35 (2010) 1169–1174. doi:10.1016/j.renene.2009.10.039.
- [11] L. Liu, Z. Yu, H. Zhang, H. Yang, Performance improvements of a ground sink direct cooling system under intermittent operations, *Energy Build.* 116 (2016) 403–410. doi:https://doi.org/10.1016/j.enbuild.2016.01.032.
- [12] Y. Shang, M. Dong, S. Li, Intermittent experimental study of a vertical ground source heat pump system, *Appl. Energy.* 136 (2014) 628–635. doi:10.1016/j.apenergy.2014.09.072.
- [13] L.R. Ingersoll, O.J. Zobel, A.C. Ingersoll, *Heat conduction, with engineering and geological applications*, McGraw-Hill Book Co., 1948.
- [14] M. Ouzzane, P. Eslami-Nejad, M. Badache, Z. Aidoun, New correlations for the prediction of the undisturbed ground temperature, *Geothermics.* 53 (2015) 379–384. doi:10.1016/j.geothermics.2014.08.001.
- [15] J.D. Spitler, S.E.A. Gehlin, Thermal response testing for ground source heat pump systems - An historical review, *Renew. Sustain. Energy Rev.* 50 (2015) 1125–1137. doi:10.1016/j.rser.2015.05.061.
- [16] A. Vieira, M. Alberdi-Pagola, P. Christodoulides, S. Javed, F. Loveridge, F. Nguyen, F. Cecinato, J. Maranhã, G. Florides, I. Prodan, G. Van Lysebetten, E. Ramalho, D.

- Salciarini, A. Georgiev, S. Rosin-Paumier, R. Popov, S. Lenart, S.E. Poulsen, G. Radioti, Characterisation of ground thermal and thermo-mechanical behaviour for shallow geothermal energy applications, *Energies*. 10 (2017). doi:10.3390/en10122044.
- [17] W.. Leong, V.. Tarnawski, A. Aittomäki, Effect of soil type and moisture content on ground heat pump performance: Effet du type et de l'humidité du sol sur la performance des pompes à chaleur à capteurs enterrés, *Int. J. Refrig.* 21 (1998) 595–606. doi:10.1016/S0140-7007(98)00041-3.
- [18] S. Erol, B. François, Efficiency of various grouting materials for borehole heat exchangers, *Appl. Therm. Eng.* 70 (2014) 788–799. doi:10.1016/j.applthermaleng.2014.05.034.
- [19] L. Jun, Z. Xu, G. Jun, Y. Jie, Evaluation of heat exchange rate of GHE in geothermal heat pump systems, *Renew. Energy*. 34 (2009) 2898–2904. doi:10.1016/j.renene.2009.04.009.
- [20] P.D. Pouloupatis, S.A. Tassou, P. Christodoulides, G.A. Florides, Parametric analysis of the factors affecting the efficiency of ground heat exchangers and design application aspects in Cyprus, 103 (2017).
- [21] K.P. Tsagarakis, L. Efthymiou, A. Michopoulos, A. Mavragani, A.S. Anđelković, F. Antolini, M. Bacic, D. Bajare, M. Baralis, W. Bogusz, S. Burlon, J. Figueira, M.S. Genç, S. Javed, A. Jurelionis, K. Koca, G. Rzyżyński, J.F. Urchueguia, B. Žlender, A review of the legal framework in shallow geothermal energy in selected European countries: Need for guidelines, *Renew. Energy*. (2018). doi:10.1016/J.RENENE.2018.10.007.
- [22] S. Javed, H. Nakos, J. Claesson, A Method to Evaluate Thermal Response Tests on Groundwater-filled Boreholes, 118 (2012) 540–549.
- [23] S. Javed, Thermal modelling and evaluation of borehole heat transfer., Chalmers University of Technology, 2012.
- [24] A. Gustafsson, L. Westerlund, Multi-injection rate thermal response test in groundwater filled borehole heat exchanger, *Renew. Energy*. 35 (2010) 1061–1070. doi:10.1016/j.renene.2009.09.012.
- [25] A.M. Gustafsson, S. Gehlin, Influence of natural convection in water-filled boreholes for GCHP, *ASHRAE Trans.* 114 PART 1 (2008) 416–423.
- [26] S. Javed, J.D. Spitler, P. Fahlén, An experimental investigation of the accuracy of thermal response tests used to measure ground thermal properties, 117 (2011) 13–22.
- [27] J.D. Spitler, S. Javed, R.K. Ramstad, Natural convection in groundwater-filled boreholes used as ground heat exchangers, *Appl. Energy*. 164 (2016) 352–365. doi:10.1016/j.apenergy.2015.11.041.
- [28] S. Javed, J.D. Spitler, B.S. Engineering, U. States, Calculation of borehole thermal resistance 3, 2016. doi:10.1016/B978-0-08-100311-4.00003-0.
- [29] C. Han, X. Yu, Sensitivity analysis of a vertical geothermal heat pump system, *Appl. Energy*. 170 (2016) 148–160. doi:10.1016/j.apenergy.2016.02.085.
- [30] H. Zhou, J. Lv, T. Li, Applicability of the pipe structure and flow velocity of vertical ground heat exchanger for ground source heat pump, *Energy Build.* 117 (2016) 109–119.

doi:10.1016/j.enbuild.2016.02.028.

- [31] R.A. Beier, M.S. Mitchell, J.D. Spitler, S. Javed, Validation of borehole heat exchanger models against multi-flow rate thermal response tests, *Geothermics*. 71 (2018) 55–68. doi:10.1016/j.geothermics.2017.08.006.
- [32] C.J. Wood, H. Liu, S.B. Riffat, Comparative performance of “U-tube” and “coaxial” loop designs for use with a ground source heat pump, *Appl. Therm. Eng.* 37 (2012) 190–195. doi:10.1016/j.applthermaleng.2011.11.015.
- [33] D. Banks, *An introduction to thermogeology: ground source heating and cooling*, John Wiley & Sons, 2012.
- [34] C. Yavuzturk, *Modeling of vertical ground loop heat exchangers for ground source heat pump systems*, Oklahoma State University USA, 1999.
- [35] A. Casasso, R. Sethi, Efficiency of closed loop geothermal heat pumps: A sensitivity analysis, *Renew. Energy*. 62 (2014) 737–746. doi:10.1016/j.renene.2013.08.019.
- [36] S. Javed, J. Spitler, Accuracy of borehole thermal resistance calculation methods for grouted single U-tube ground heat exchangers, *Appl. Energy*. 187 (2017) 790–806. doi:10.1016/j.apenergy.2016.11.079.
- [37] P. Eskilson, *Thermal analysis of heat extraction boreholes*, Department of Mathematical Physics, University of Lund Lund., Sweden, 1987.
- [38] T. Persson, O. Stavset, R.K. Ramstad, M.J. Alonso, K. Lorenz, *Software for modelling and simulation of ground source heating and cooling systems*, (2016).
- [39] A. Michopoulos, N. Kyriakis, The influence of a vertical ground heat exchanger length on the electricity consumption of the heat pumps, *Renew. Energy*. 35 (2010) 1403–1407. doi:10.1016/j.renene.2009.11.009.
- [40] ASHRAE, *ASHRAE Handbook - HVAC Systems and Equipment*, Am. Soc. Heating, Refrig. Air Cond. Eng. Atlanta. (2012).
- [41] K.W.K. Archid, B.W. Olesen, Part One: Radiant Heating and Cooling Systems, *ASHRAE J.* 57 (2015) 28.
- [42] P. Simmonds, I. Chambers, B. Mehlomakulu, C. Simmonds, *Applied Performance of Radiant Ceiling Panels for Cooling.*, *ASHRAE Trans.* 112 (2006).
- [43] Y. Jiang, X. Liu, L. Zhang, T. Zhang, High Temperature Cooling and Low Temperature Heating in Buildings of EBC Annex 59, *Energy Procedia*. 78 (2015) 2433–2438. doi:10.1016/j.egypro.2015.11.222.
- [44] M. Ala-Juusela, *Heating and Cooling with Focus on Increased Energy Efficiency and Improved Comfort: Guidebook to IEA ECBCS Annex 37 Low Exergy Systems for Heating and Cooling of Buildings*, VTT, 2004.
- [45] D. Schmidt, Low exergy systems for high-performance buildings and communities, *Energy Build.* 41 (2009) 331–336. doi:10.1016/j.enbuild.2008.10.005.

- [46] J. Babiak, B.W. Olesen, D. Petras, Low temperature heating and high temperature cooling, Rehva, 2009.
- [47] International Organization for Standardization, ISO 18566. Building environment design - Design, test methods, control and operation of radiant heating and cooling panel systems, Geneva, 2013.
- [48] International Organization for Standardization, ISO 11855. Building environment design - Design, dimensioning, installation and control of embedded radiant heating and cooling systems, 2012.
- [49] K. Roth, J. Dieckmann, R. Zogg, J. Brodrick, Chilled beam cooling, ASHRAE J. 49 (2007) 84.
- [50] J. Woollett, J. Rimmer, Active and Passive Beam Application Design Guide, Brussels REHVA-Federation Eur. Heat Ing, Vent lation Air Cond. Assoc. (2014).
- [51] M. Virta, D. Butler, J. Graslund, J. Hogeling, E.L. Kristiansen, Chilled Beam Application Guidebook, Rehva Guidebook No 5, ISBN 2-9600468-3-8, 2005.
- [52] X. Liu, Y. Jiang, T. Zhang, Temperature and humidity independent control (THIC) of air-conditioning system, Springer Science & Business Media, 2014. doi:10.1007/978-3-642-42222-5.
- [53] H.E. Feustel, C. Stetiu, Hydronic radiant cooling — preliminary assessment, Energy Build. 22 (1995) 193–205. doi:10.1016/0378-7788(95)00922-K.
- [54] P.O. Fanger, B.M. Ipsen, G. Langkilde, B.W. Olessen, N.K. Christensen, S. Tanabe, Comfort limits for asymmetric thermal radiation, Energy Build. 8 (1985) 225–236. doi:10.1016/0378-7788(85)90006-4.
- [55] D.L. Loveday, K.C. Parsons, A.H. Taki, S.G. Hodder, Designing for thermal comfort in combined chilled ceiling/displacement ventilation environments/Discussion, ASHRAE Trans. 104 (1998) 901.
- [56] B.W. Olesen, Thermo Active Building Systems: Using Building Mass To Heat and Cool, ASHRAE J. 54 (2012) 44–52.
- [57] G. Hauser, C. Kempkes, B.W. Olesen, Computer simulation of hydronic heating/cooling system with embedded pipes, Univ. of Kassel (DE), 2000.
- [58] B. Lehmann, V. Dorer, M. Koschenz, Application range of thermally activated building systems tabs, Energy Build. 39 (2007) 593–598. doi:10.1016/j.enbuild.2006.09.009.
- [59] X. Xu, S. Wang, J. Wang, F. Xiao, Active pipe-embedded structures in buildings for utilizing low-grade energy sources: A review, Energy Build. 42 (2010) 1567–1581. doi:10.1016/j.enbuild.2010.05.002.
- [60] R.A. Meierhans, Slab cooling and earth coupling, ASHRAE Trans. 99 (1993) 511–520.
- [61] G.P. Henze, C. Felsmann, D.E. Kalz, S. Herkel, Primary energy and comfort performance of ventilation assisted thermo-active building systems in continental climates, Energy Build. 40 (2008) 99–111. doi:10.1016/j.enbuild.2007.01.014.

- [62] J. Woolley, S. Schiavon, F. Bauman, P. Raftery, J. Pantelic, Side-by-side laboratory comparison of space heat extraction rates and thermal energy use for radiant and all-air systems, *Energy Build.* 176 (2018) 139–150. doi:10.1016/j.enbuild.2018.06.018.
- [63] F. Causone, S.P. Corgnati, M. Filippi, B.W. Olesen, Solar radiation and cooling load calculation for radiant systems: Definition and evaluation of the Direct Solar Load, *Energy Build.* 42 (2010) 305–314. doi:10.1016/j.enbuild.2009.09.008.
- [64] B.W. Olesen, Thermal comfort requirements for floors occupied by people with bare feet, *ASHRAE Trans.* 83 (1977).
- [65] ASHRAE, *ASHRAE Handbook - HVAC Fundamentals*, Am. Soc. Heating, Refrig. Air Cond. Eng. Atlanta. (2013).
- [66] B. Olesen, Radiant floor cooling systems, *ASHRAE J.* 50 (2008) 16–22.
- [67] B.W. Olesen, M. De Carli, M. Scarpa, M. Koschenz, Dynamic Evaluation of the Cooling Capacity of Thermo-Active Building Systems., *ASHRAE Trans.* 112 (2006).
- [68] K.-N. Rhee, K.W. Kim, A 50 year review of basic and applied research in radiant heating and cooling systems for the built environment, *Build. Environ.* 91 (2015) 166–190. doi:10.1016/j.buildenv.2015.03.040.
- [69] International Organization for Standardization, *ISO 11855-4:Building environment design - Design, dimensioning, installation and control of embedded radiant heating and cooling systems -- Part 4: Dimensioning and calculation of the dynamic heating and cooling capacity of Thermo Active Building Systems*, 2012.
- [70] C.R. MacCluer, The temperature stability of a radiant slab-on-grade, *ASHRAE Trans.* 95 (1989) 1001–1009.
- [71] S.R. Ryu, J.H. Lim, M.S. Yeo, K.W. Kim, A Study on the Control Methods for Radiant Floor Heating and Cooling System in Residential Building., *ASHRAE Trans.* 110 (2004) 106–116.
- [72] J.-H. Lim, J.-H. Jo, Y.-Y. Kim, M.-S. Yeo, K.-W. Kim, Application of the control methods for radiant floor cooling system in residential buildings, *Build. Environ.* 41 (2006) 60–73. doi:10.1016/j.buildenv.2005.01.019.
- [73] P. Fahlén, Capacity control of air coils for heating and cooling: Transfer functions, drive power and system design, Rep. R200701 Rev3. (2012).
- [74] P. Fahlén, C. Markusson, C.H. Stignor, Capacity control of liquid-cooled air-coolers, in: 2007.
- [75] S.-H. Cho, M. Zaheer-uddin, Temperature regulation of radiant floor heating systems using two-parameter on-off control: An experimental study, *ASHRAE Trans.* 103 (1997) 966–980.
- [76] D. Adelman, Some control strategies for radiant floor heating, *Radiant Times.* (1988) 4–5.
- [77] ISO-DIS, *ISO 18566-4:Building Environment Design - Design, test methods and control of hydronic radiant heating and cooling panel systems- part 4: Control of ceiling mounted*

heating and cooling panels, 2013.

- [78] J. Graslund, nZEB headquarters of Skanska, Rehva. (2014) 44–47.
- [79] LGGInneklimat, Cassette air cooler, (2019). <http://www.lgg.se/top-line-ecm>.
- [80] H. Tang, P. Raftery, X. Liu, S. Schiavon, J. Woolley, F.S. Bauman, Performance analysis of pulsed flow control method for radiant slab system, *Build. Environ.* 127 (2018) 107–119. doi:10.1016/j.buildenv.2017.11.004.
- [81] ISO-DIS, ISO 18566-2:Building Environment Design - Design, test methods and control of hydronic radiant heating and cooling panel systems- part 2: Determination of heating and cooling capacity of ceiling mounted radiant panels, 2017.
- [82] ISO-DIS, ISO 18566-3:Building Environment Design - Design, test methods and control of hydronic radiant heating and cooling panel systems- part 3: Design of ceiling mounted radiant panels, 2017 (2018).