

# Multi-scale uncertainty analysis – A tool to systematically consider variability in lignocellulosic bioethanol processes

Nickel, D. B. (Chalmers University of Technology), Fornell, R. (RISE Research Institutes of Sweden), Janssen, M., Franzén, C. J. (both Chalmers University of Technology)

## 1 Introduction

Fuel ethanol derived from renewable resources, called bioethanol, is regarded to be an important substitute for fossil fuels in the transport sector. As part of governmental efforts to reach set climate goals, bioethanol contributes to a sustainable transformation of this sector by replacing gasoline in cars and trucks [1]. Today, most bioethanol plants utilize starch-based raw materials, e.g. corn. To avoid competition with food supply and exploit the utilization of agricultural and forestry waste products, the research focus has shifted to lignocellulosic raw materials such as corn stover and wheat straw.

Generally, the bioethanol process starts with a raw material pretreatment under severe conditions to open the lignocellulosic structure. In a hydrolysis step, enzymes are added which release sugars from the material. These sugars are converted during fermentation by microorganisms into ethanol. A common process configuration is simultaneous saccharification and fermentation (SSF) in which hydrolysis and fermentation to ethanol are performed in one step.

The choice of process design heavily depends on the raw material composition. However, raw materials and enzymes are highly prone to batch-to-batch variations. For example, raw material characteristics vary depending on harvest time and location. To facilitate bioethanol process design and development, to evaluate process performance regarding economics and sustainability, and to design experiments to identify hotspots for optimization, tools are required to incorporate variability assessment into a multi-scale process analysis and modelling framework.

Here we present a multi-scale uncertainty analysis framework including the assessment of variability in process inputs for a bioethanol process. The framework covers the dynamic simulation of the bioprocess (hydrolysis and fermentation), the generation of mass and energy balances in flowsheet software to assess process economics, and conducting life cycle assessments. The presentation will focus on the integration of the different modelling and analysis tools and the workflow of multi-scale uncertainty analysis. Using the example of propagating variability in enzyme activity through the multi-scale framework we show how variability in process inputs affects process designs, economics and sustainability.

## 2 Results

The multi-scale uncertainty analysis framework covers three different system scales: A dynamic simulation of the SSF bioprocess, the generation of mass and energy balances for the complete ethanol production process and the life cycle assessment for the ethanol production process including upstream processes, e.g. the cultivation of the raw material.

First, process information data and variable input data are assessed to start dynamic simulations in MATLAB R2016b. The model describing the SSF bioprocess contains four explicit algebraic and eight differential equations and has been validated experimentally previously [2]. After the simulation a local OLE automation server is created to transfer simulation results to MS Excel.

Simulation data are imported into SuperPro Designer, a flowsheet software (see Fig. 1). The flowsheet model calculates the energy and mass balances for the bioethanol production process, starting from raw material pretreatment, including the simulation of hot and cold utility systems as well as waste water treatment, and ending with the final product. Equipment cost are based on the built-in library of SuperPro Designer and have been adjusted using literature data when deemed necessary [3]. Data about operating and raw material cost were validated against a bioethanol reference process at 10 m<sup>3</sup> demonstration scale, described in [2]. Ethanol yields are retrieved from the dynamic bioprocess simulations. The results of the general mass and energy balances are stored in MS Excel.

The life cycle assessment (LCA) is performed in openLCA based on the dynamic bioprocess simulations and the assessment of general mass and energy balances with the goal to determine the environmental impact of bioethanol production given variable inputs. The assessment focuses on bioethanol production

from pretreatment of raw materials until leaving the production site (well-to-gate analysis). Therefore, the life-cycle inventory is compiled based on the data from previous systems scales and databases. The inventory is used to calculate the environmental impact based on the required resources and emissions of the process. Resulting data are stored in a .csv-file.

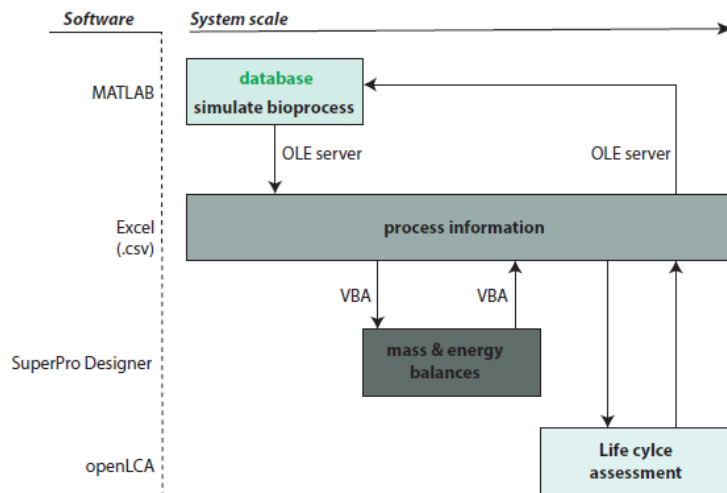

Fig. 1  
Software and data flows in multi-scale uncertainty analysis framework

The results from all three system scales are statistically analyzed and compared to investigate whether the input variability affects the results significantly. If so, experiments must be designed to restrict variability. Furthermore, the multi-scale framework pinpoints possible process designs and identifies hotspots for optimization.

The multi-scale uncertainty framework was applied to study the effect of variability in enzyme activity. Data on enzyme activities were retrieved through a literature search. The resulting dataset (N= 480 publications) was further delimited by considering only one measurement method [4] to enhance comparability, resulting in N = 71 enzymatic activities. This dataset was statistically analyzed and afterwards used to propagate the data into the bioprocess model. Several process configurations were simulated to compare them within in the developed multi-scale framework. Results show that feeding enzyme during the process restricts the variability, enabling precise process control and high predictability whereas enzyme addition only at the process start results in significantly higher confidence regions regarding process time and final product concentration.

### 3 Conclusions

A multi-scale uncertainty analysis framework was developed to assess a bioethanol process regarding process dynamics, economics and life cycle environmental impacts. Thereby, feasible process designs, and hotspots for optimization and experimental design can be identified.

### 4 References

1. EU, *Directive 2009/28/EC of the European Parliament and of the Council of 23 April 2009 on the promotion of the use of energy from renewable sources and amending and subsequently repealing Directives 2001/77/EC and 2003/30/EC*, in *Official Journal of the European Union*. 2009. p. 2009.
2. Wang, R., P. Unrean, and C.J. Franzén, *Model-based optimization and scale-up of multi-feed simultaneous saccharification and co-fermentation of steam pre-treated lignocellulose enables high gravity ethanol production*. *Biotechnology for Biofuels*, 2016. **9**(1): p. 88.
3. Humbird, D., et al., *Process design and economics for biochemical conversion of lignocellulosic biomass to ethanol: dilute-acid pretreatment and enzymatic hydrolysis of corn stover*. 2011, National Renewable Energy Laboratory (NREL), Golden, CO.
4. Ghose, T., *Measurement of cellulase activities*. *Pure and applied Chemistry*, 1987. **59**(2): p. 257-268.