



A 110-170 GHz transceiver in 130 nm SiGe BiCMOS technology for FMCW applications

Downloaded from: <https://research.chalmers.se>, 2026-04-05 05:05 UTC

Citation for the original published paper (version of record):

Yan, Y., Bryllert, T., Vassilev, V. et al (2018). A 110-170 GHz transceiver in 130 nm SiGe BiCMOS technology for FMCW applications. Proceedings of SPIE - The International Society for Optical Engineering, 10800. <http://dx.doi.org/10.1117/12.2318791>

N.B. When citing this work, cite the original published paper.

A 110-170 GHz Transceiver in 130 nm SiGe BiCMOS Technology for FMCW Applications

Yu Yan*^a, Tomas Bryllert^b, Vessen Vassilev^a, Sten E. Gunnarsson^a, Herbert Zirath^a

^aMicrowave Electronics Laboratory, Department of Microtechnology and Nanoscience (MC2), Chalmers University of Technology, Göteborg SE-41296, Sweden; ^bTerahertz and Millimetre Wave Laboratory, Department of Microtechnology and Nanoscience (MC2), Chalmers University of Technology, Göteborg SE-41296, Sweden

ABSTRACT

A 110-170 GHz transceiver is designed and fabricated in a 130 nm SiGe BiCMOS technology. The transceiver operates as an amplifier for transmitting and simultaneously as a fundamental mixer for receiving. In a measured frequency range of 120-160 GHz, a typical output power of 0 dBm is obtained with an input power of +3 dBm. As a fundamental mixer, a conversion gain of -9 dB is obtained at 130 GHz LO, and a noise figure of 19 dB is achieved. The transceiver is successfully demonstrated as a FMCW radar front-end for distance measurement. With a chirp rate of 1.6×10^{12} Hz/s and a bandwidth of 14.4 GHz, a range resolution of 2.8 cm is demonstrated, and transmission test is shown on different objects.

Keywords: transceiver, radar front-end, FMCW, amplifier, mixer, power, conversion gain, noise figure, 130 nm, SiGe, BiCMOS, HBT, chirp rate, range resolution, transmission.

1. INTRODUCTION

In most commercial imaging techniques for security applications, the sensor needs to be in close proximity to the target. However, to survive a person borne improvised explosive device (IED) even without shrapnel, at least 5 meters separation distance is required [1]. Therefore, standoff imaging, which is capable of detecting concealed weapons, explosives, or hidden contraband, tends to be increasingly important for security applications.

Using radar technologies, the 100 GHz to 1 THz region is interesting for standoff detection of concealed objects [2]. The cross-range resolution is proportional to the wavelength of the transmitted signal, and the range resolution is inversely proportional to the frequency bandwidth, which is also related to the operating frequency [3]. In general, higher operating frequency gives better range resolution and cross-range resolution. Furthermore, as the frequency increases above 500 GHz, the aperture sizes become more manageable. However, the attenuation of the atmosphere and clothing will be affected significantly as the frequency increase. In the 100-600 GHz frequency range, transmission has been experimentally shown on a variety of clothing [4]. Using an overcoat as an example, the measured transmission decreases from the peak value of more than 0.8 down to around 0.5 as the frequency increases from 192 GHz to 576 GHz. To compensate the attenuation, active systems can be a choice. By employing frequency-modulated continuous wave (FMCW) radar technique, Jet Propulsion Laboratory (JPL) has developed a 580-GHz imaging radar [5], followed by a 600 GHz version [6], and the latest updated 675 GHz one [7]. In the coherent transceiver front-ends of the three versions, the transmitters are constructed by multiplier chains and power amplifiers, while the receivers are formed by mixers driven by multipliers. Schottky diodes are employed in all the multipliers and mixers using traditional waveguide technology. In addition, to achieve high-isolation duplexing, a high-resistivity silicon etalon beam splitter is used at the expense of losing half of the beam power for both transmitter and receiver. In the best case, this duplexing method introduces a round-trip loss of 6 dB. In order to simplify the bulky transmitter/receiver chains and overcome the power loss from duplexing method, an integrated FMCW radar transceiver module, which operates as a frequency doubler for transmitting and simultaneously as a sub-harmonic mixer for receiving, is reported at 200-240 GHz [3]. The waveguide technology is employed by the transceiver module, in which the transceiver circuits are fabricated on 3- μ m thick GaAs membranes which contains GaAs Schottky diodes.

According to [3] and [7], a single transceiver is not enough to provide the necessary frame rate for real-time standoff imaging. The most practical solution is to use an array of transceivers. To stack single transceivers into an array, monolithically integrated circuit technologies would be more efficient in terms of space and cost compared to the ones in traditional waveguide technology [8]. At frequencies above 500 GHz, key components of a transceiver may be more challenging to realize in transistor based technologies than Schottky diode technologies. However, as it is pointed out in [2], transmission loss in atmosphere and clothing tends to drive designs to lower frequencies (e.g. below 500 GHz). The transistor based active circuits would possibly have gain to achieve adequate sensitivity and signal to noise ratio.

In this paper, a transceiver, which operates as an amplifier for transmitting and simultaneously as a fundamental mixer for receiving, is designed at 110-170 GHz and can be stacked linearly on-chip to form a compact transceiver array. This transceiver can then be used as a FMCW radar front-end. The circuit is fabricated in Infineon’s 130 nm SiGe BiCMOS technology (B11HFC), which has a typical f_T/f_{max} of 250/435 GHz. The given technology consists of 6 metal layers for interconnection and offers the opportunity of high integration level.

2. TRANSCEIVER CIRCUIT DESIGN

The original idea of sharing a single circuit for FMCW front-end operation including both transmitter and receiver was first demonstrated in [9]. That first presented FMCW radar transceiver front-end, which consists two diodes and a few passive components on a printed circuit board, operates as a frequency multiplier for transmitting, and simultaneously as a sub-harmonically pumped “I/Q” mixer for receiving. Then, by choosing a field effect transistor (FET) as the only nonlinear device, a transceiver circuit was designed and demonstrated simultaneously as an amplifier and a resistive mixer at around 10 GHz [10]. Using it as the prototype, a balanced FMCW transceiver is presented with improved AM noise performance [11]. Again, in [3], the measured IF noise power is largely suppressed from the balanced transceiver module compared to the unbalanced one.

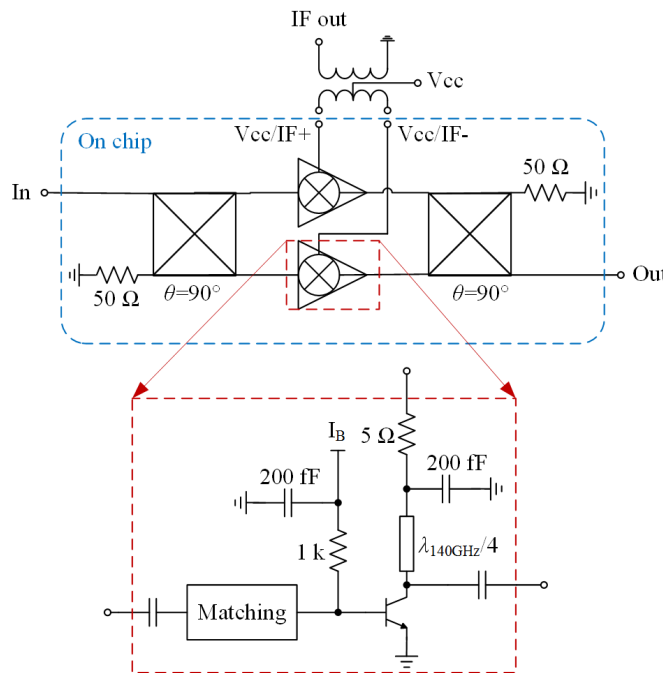

Figure 1. Schematic of the transceiver.

Since the IF noise performance is extremely important for standoff imaging applications, a balanced configuration is chosen in this work. The schematic of the designed transceiver is shown in Fig. 1. The circuit is designed to operate as an amplifier for transmitting and simultaneously as a fundamental mixer for receiving. The input signal not only applies as the input for the amplifier but also serves as the local oscillator (LO) signal for the mixer. Then, the transmitted signal will be echoed back into the output port and applied as RF for the mixer. In the presented transceiver circuit, the active

devices are two high speed *npn* transistors (emitter size: $0.13 \times 10 \mu\text{m}^2$) from the given technology, and they are biased in class-AB condition for a compromised performance as an amplifier and a mixer. The two identical single-ended common emitter stages are combined by a 90° branch line hybrid at the input and another 90° branch line hybrid at the output. Therefore, the output signals from the two common emitter stages will be combined in-phase from the transmitter's view, and the generated IF signals will be 180° out-of-phase from the receiver's view. On the integrated transceiver chip, the IF signals share the same path as the collector dc bias lines. In addition, IF signals generated from a short range FMCW radar are normally within a frequency range of kHz or MHz. Therefore, large capacitors and inductors (e.g. bias tee) would be needed to isolate the dc bias from the IF port. However, the capacitor and inductor, which intend to couple out and block few kHz IF frequencies, would occupy unacceptable large chip areas in given technology, so they are omitted on-chip and off-chip components will instead be used.

The circuit is designed and optimized in Cadence Virtuoso and some essential passive components (e.g. the 90° branch line hybrid and matching networks) are EM simulated in Sonnet. Fig. 2 shows the chip photo of the fabricated transceiver circuit. The 90° branch line hybrids are meandered to save space, and the base dc bias of the two transistors are combined on-chip into a single dc pad. The transceiver chip occupies a chip area of $980 \times 560 \mu\text{m}^2$.

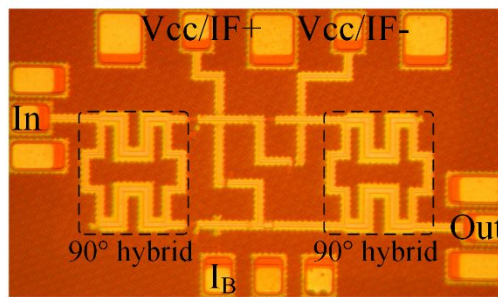

Figure 2. Chip photo of the transceiver circuit. (Size: $980 \times 560 \mu\text{m}^2$).

In this work, a commercial off-chip transformer (ADT4-6T from Mini-Circuits) is used to convert the differential IF outputs to a single-ended output, and its center tap is used to apply collector dc bias. Fig. 3 shows the photo of the balanced transceiver circuit together with the off-chip transformer. The transformer is surface mounted on a designed printed circuit board (PCB), which is further mounted on a brass block by silver epoxy. The secondary terminals of the transformer are connected to the two on-chip Vcc/IF pads through bond wires. Since the chip has no back metallization for grounding, a small gold plate is conductively glued on the brass block and sits between the circuit chip and the PCB. When connecting the on-chip ground pads and the gold plate through bond wires, common ground between the chip and the PCB is obtained.

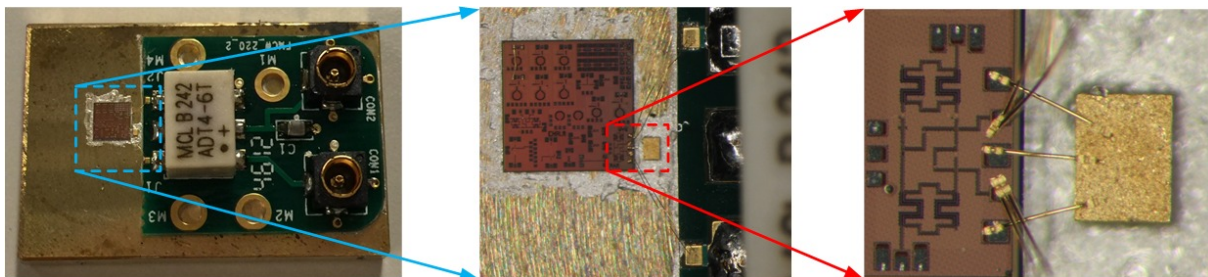

Figure 3. Photo of the balanced transceiver circuit connected with off-chip transformer.

3. CIRCUIT MEASUREMENT

On-chip measurement is applied to the fabricated transceiver circuit, where the input/output ports and dc bias are connected through probes. The circuit is characterized as an amplifier and a mixer.

To characterize it as an amplifier, the single-ended IF port is terminated by a 50Ω load. Two-port small signal S-parameter measurement is applied at D-band (110-170 GHz). At the dc biases of $I_B=34 \mu\text{A}$ and $V_{cc}=1.6 \text{ V}$, Fig. 4 shows both the measured and simulated small signal S-parameters. Reasonable agreement of S21 and S12 is achieved in the

whole D-band. Measured S11 and S22 show that both input and output ports are well matched. From the measured S21, no power gain is obtained. However, from the transmitter's point of view, the maximum output power is more crucial. Therefore, the output power is measured as a function of the input power, where the input is applied by the VDI D-band source module followed by a tunable attenuator and the output power is measured by an Erickson power meter. Fig. 5 shows both the measured and simulated results at 140 GHz. As can be seen from the measured results, more than 0 dBm output power is obtained with an input power of ~3 dBm, and the gain is still linear at this power level. At the frequency range of 120-160 GHz, the maximum output power is measured when the maximum available power from the VDI D-band source module is applied. This is shown in fig. 6, in which the measured maximum input power is also included as a reference.

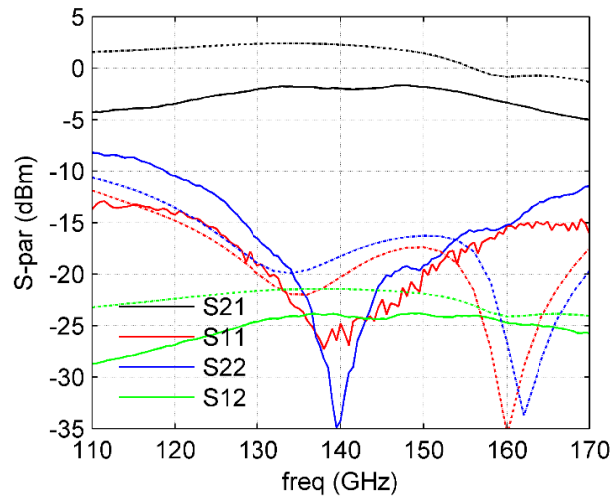

Figure 4. Measured (solid lines) and simulated (dashed lines) small signal S-parameters.

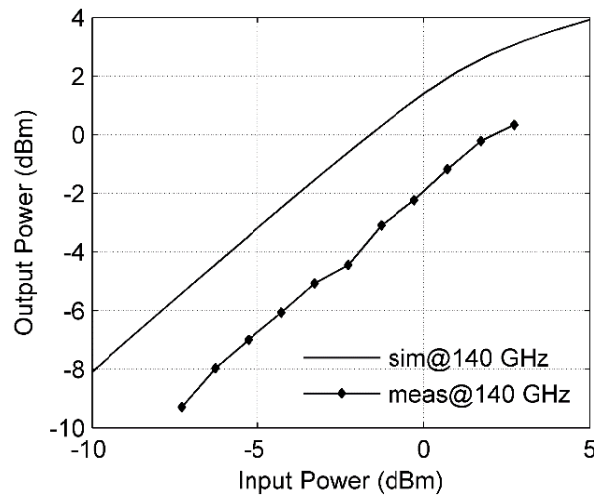

Figure 5. Measured and simulated output power in transmit mode as a function of the input power at 140 GHz.

When characterizing the circuit as a mixer, the input is applied by the VDI D-band source module with a maximum available power and serves as LO. The output is applied by a VDI D-band extender with a power level of around -20 dBm and serves as the RF. By measuring the output IF power, conversion gain of the mixer can be obtained. With a LO power of around 3 dBm (the LO power at different frequencies is shown as $P_{in,max}$ in fig. 6), fig. 7(a) shows the measured conversion gain as a function of the LO frequencies at a fixed IF frequency of 10 MHz. Fig. 7(b) shows the measured

conversion gain as a function of the IF frequencies at a fixed LO frequency of 130 GHz. The IF frequency is only swept up to 300 MHz, which is the upper limit of the transformer in use. Typical conversion gain of -10~-12 dB is obtained.

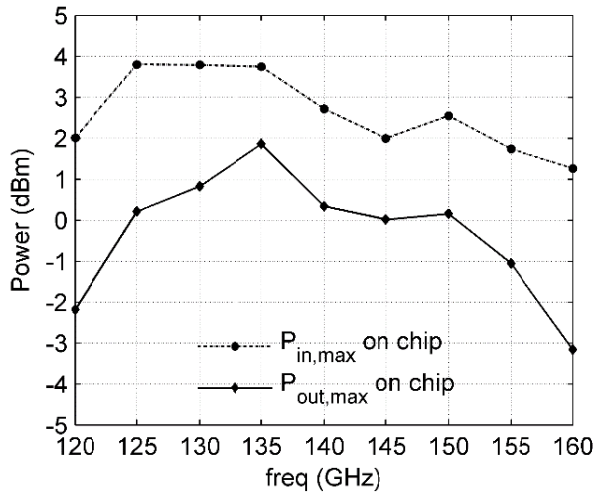

Figure 6. Measured maximum available power to feed in and the maximum available power from the output.

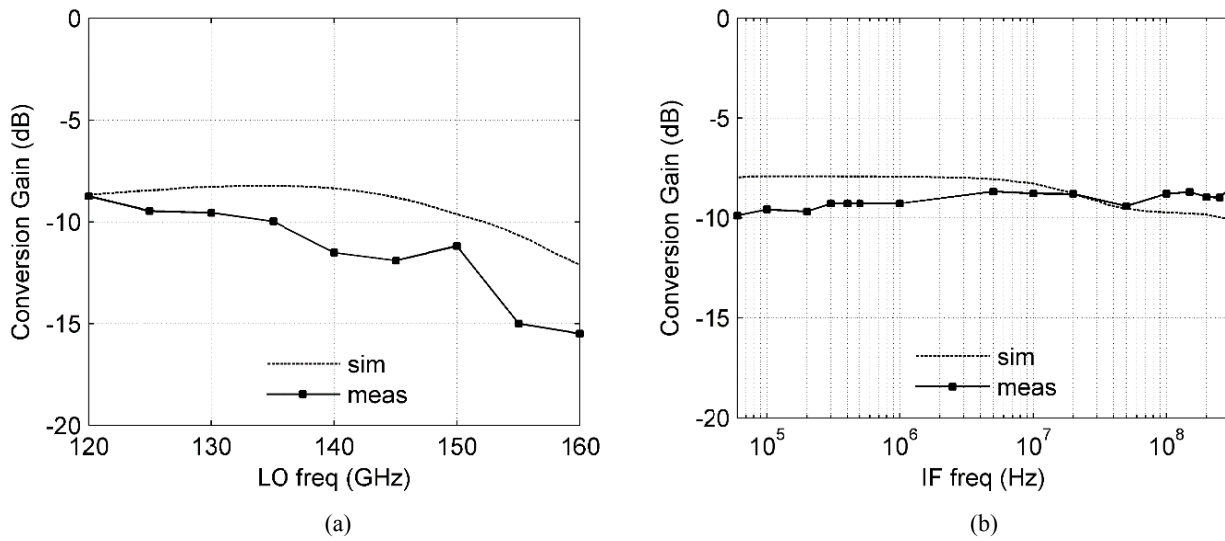

Figure 7. (a) Simulated and measured conversion gain in receive mode as a function of the LO frequencies ($f_{IF}=10$ MHz).

(b) Simulated and measured conversion gain in receive mode as a function of the IF frequencies ($f_{LO}=130$ GHz).

To evaluate the noise performance of the mixer, the IF noise power is first amplified by a low noise amplifier, which has a typical gain of $G_{LNA}=50$ dB and a typical noise figure of $NF_{LNA}=2.5$ dB, and further measured by a spectral analyzer. With a resolution bandwidth (RBW) of 1 MHz for the spectral analyzer, fig. 8 shows the measured IF noise power at different conditions. A typical IF noise power of $P_{IF}=-53$ dBm is obtained when the transceiver circuit is dc biased and 130 GHz LO pumped. From fig. 7 (b), a typical conversion gain of $G_{mixer}=-9$ dB can be read. Therefore, the noise figure of the mixer can be calculated from:

$$P_{IF} = k(T_0 + T_{tot})BG_{tot} \quad (1)$$

$$T_{tot} = T_{mixer} + \frac{T_{LNA}}{G_{mixer}} \quad (2)$$

$$G_{tot} = G_{mixer} \times G_{LNA} \quad (3)$$

where

- $K=1.38 \times 10^{-13}$ J/K is the Boltzmann constant;
- $T_0=295$ K is the standard room temperature;
- $B=RBW \times 1.128$ is the equivalent noise bandwidth in Hz [12].

Given all the numbers, the calculated noise figure is 19 dB.

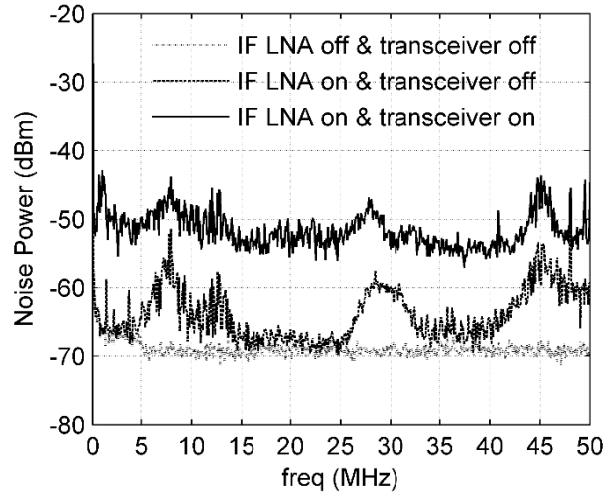

Figure 8. Measured noise power at IF.

4. FMCW RADAR MEASUREMENT

Using the designed transceiver front-end, a FMCW radar is setup and demonstrated for distance measurement. Fig. 9 shows the radar measurement setup. A chirped signal is generated by a direct digital synthesizer (DDS) and it linearly swept from 0.3 GHz to 1.2 GHz in 9 ms. After up-conversion in a mixer using a 7.8 GHz LO signal, two $\times 4$ frequency multipliers are followed. This results in a 129.6~144 GHz signal with a chirp rate of 1.6×10^{12} Hz/s to be fed into the designed transceiver front-end. At the output of the transceiver, a D-band lens corrected antenna, which has a gain of 40 dBi, is connected to the output port of the transceiver. The output IF signal is amplified by an LNA ($G_{LNA}=50$ dB and $NF_{LNA}=2.5$ dB) and measured by an oscilloscope. The IF spectra is obtained from fast Fourier transform (FFT).

The theoretical range resolution of a FMCW radar is given by:

$$\Delta r_0 = c/2BW \quad (4)$$

where c is the speed of light, and BW is the chirp bandwidth.

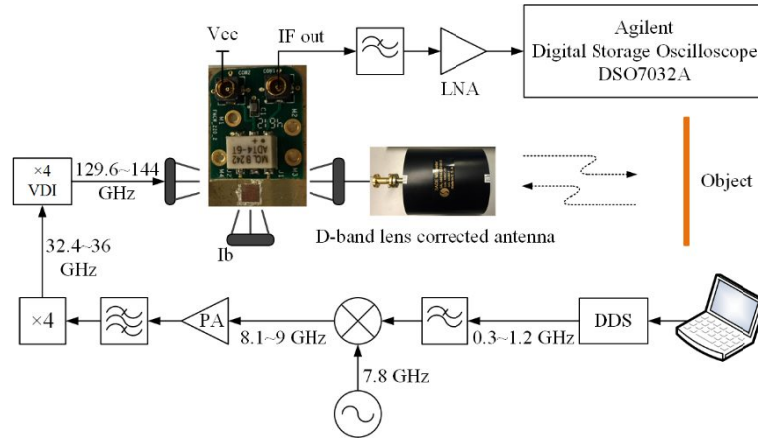

Figure 9. FMCW radar measurement setup.

In our setup with a chirp bandwidth of 14.4 GHz, it gives a theoretical range resolution of ~ 1.04 cm. In practice, the range resolution will be degraded due to nonlinearities and windowing in the post processing [5]. In the measurement, the range resolution is demonstrated by placing two cardboard layers (which are actually the two layers from a cardboard box and the distance in between is tuned by replacing boxes with different thicknesses) along with the beam travel direction. Fig. 10 shows the measured IF spectra when a ~ 3 cm thick cardboard box is used as the target. The two IF peaks can be recognized with a frequency separation (Δf) of 300 Hz, which results in a distance (D) of:

$$D = \frac{\Delta f \times c}{2 \times \text{chirp rate}} \approx 2.81 \text{ (cm)} \quad (5)$$

This agrees with the value of ~ 3 cm, which is measured by a ruler.

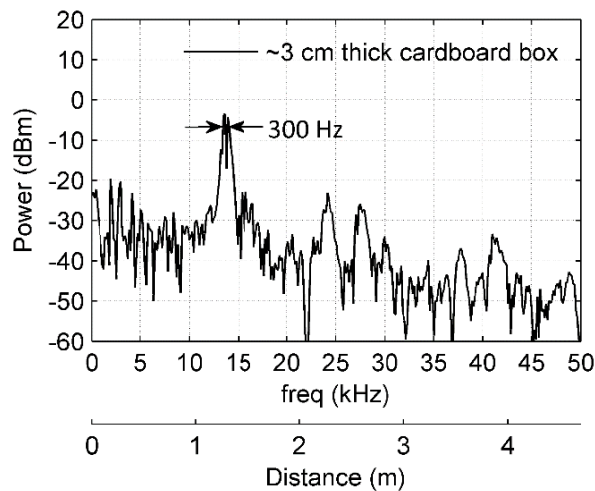

Figure 10. Measured IF spectra when the target is a ~ 3 cm thick cardboard box.

Transmission test is also applied on several materials. As is shown in fig. 11. A big piece of metal facing the antenna is used as a reference. The object under test is then placed between the antenna and the metal reference. Fig. 12 shows the measured IF spectra with different objects. By comparing the power of the second IF peaks with the reference one, it can be seen that the signal at ~ 140 GHz penetrate through a 0.5 cm thick plastic board with barely any loss, while a 0.3 cm thick wet cardboard and a 2 cm thick wood shows around 20 dB loss and 40 dB loss, respectively, in a return path.

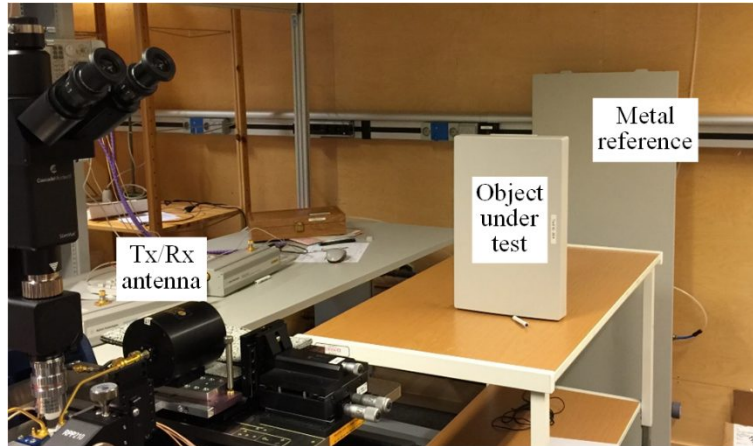

Figure 11. Transmission test setup.

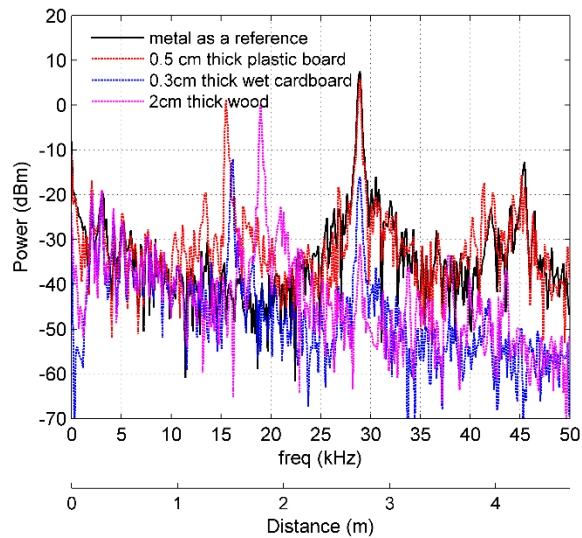

Figure 12. Measured IF spectra for transmission test.

5. CONCLUSION

Aiming for standoff imaging applications, a 110~170 GHz transceiver is designed to operate as an amplifier for transmitting and simultaneously as a fundamental mixer for receiving. The circuit is fabricated in a 130 nm SiGe BiCMOS technology. The transceiver circuit is well matched in full D-band, and in the frequency range of 120~160 GHz, a typical output power of ~0 dBm is measured with an input power of ~3 dBm. When it works as a mixer, a conversion gain of -9 dB is obtained at 130 GHz LO frequency, and a measured noise figure of 19 dB is achieved. The designed transceiver is successfully demonstrated as a FMCW radar for distance measurement. With a chirp bandwidth of 14.4 GHz and a chirp rate of 1.6×10^{12} Hz/s, a range resolution of 2.8 cm is demonstrated, and transmission loss from several objects are also measured. From the performance of the transceiver circuit alone, reasonable output power and conversion gain are obtained in a frequency bandwidth of more than 30 GHz. Therefore, a sub-cm range resolution should be achieved if the chirp signal could cover the whole bandwidth of the transceiver.

ACKNOWLEDGMENT

The authors would like to acknowledge and thank the wafer processing team at Infineon Technologies for chip manufacture.

REFERENCES

- [1] "Controlling Risks Around Explosives Stores, A Review of the Requirements on Separation Distance," [Online]. Available: <http://www.hse.gov.uk/research/misc/qdwgprep.pdf>. Crown Copyright, 2002.
- [2] R. Appleby and H. B. Wallace, "Standoff detection of weapons and contraband in the 100 GHz to 1 THz region," *IEEE Trans. Antennas Propag.*, vol. 55, no. 11, pp. 2944–2956, Nov. 2007.
- [3] T. Bryllert, V. Drakinskiy, K. B. Cooper, and J. Stake, "Integrated 200-240-GHz FMCW radar transceiver module," *IEEE Trans. Microw. Theory Techn.*, vol. 61, no. 10, pp. 3808–3815, Oct. 2013.
- [4] D. T. Petkie, F. C. De Lucia, C. Casto, P. Helminger, E. L. Jacobs, S. K. Moyer, S. Murrill, C. Halford, S. Griffin, and C. Franck, "Active and passive millimeter and sub-millimeter-wave imaging," in *Proc. SPIE*, 2005, vol. 5989, pp. 598918-1–598918-8.
- [5] K. B. Cooper, R. J. Dengler, G. Chattopadhyay, E. Schlecht, J. Gill, A. Skalare, I. Mehdi, and P. H. Siegel, "A high-resolution imaging radar at 580 GHz," *IEEE Microw. Wireless Compon. Lett.*, vol. 18, no. 1, pp. 64–66, Jan. 2008.
- [6] K. B. Cooper, R. J. Dengler, N. Llombart, T. Bryllert, G. Chattopadhyay, E. Schlecht, J. Gill, C. Lee, A. Skalare, I. Mehdi, and P. H. Siegel, "Penetrating 3-D imaging at 4 and 25 meter range using a submillimetre-wave radar," *IEEE Trans. Microw. Theory Techn.*, vol. 56, pp. 2771–2778, 2008.
- [7] K. B. Cooper, R. K. Dengler, N. Llombart, B. Thomas, G. Chattopadhyay, and P. H. Siegel, "THz imaging radar for standoff personnel screening," *IEEE Trans. THz Sci. Technol.*, vol. 1, no. 1, p. 169, 182, Sep. 2011.
- [8] M. Jahn, R. Feger, C. Pfeffer, T. F. Meister, and A. Stelzer, "A SiGe-based 140-GHz four-channel radar sensor with digital beamforming capability," in *IEEE MTT-S Int. Microw. Symp. Dig.*, Jun. 2012.
- [9] S. A. Maas, "FM-CW radar transceiver," U.S. Patent 5 596 325, Jan. 21, 1997.
- [10] K. Yhland, and C. Fager, "A FET transceiver suitable for FMCW radars," *IEEE Microwave and Guided Wave Lett.*, vol. 10, no. 9, pp. 377–379, Sep. 2000.
- [11] C. Fager, K. Yhland, and H. Zirath, "A balanced FET FMCW radar transceiver with improved AM noise performance," *IEEE Trans. Microw. Theory Techn.*, vol. 50, no. 4, pp. 1224–1227, Apr. 2002.
- [12] "Spectrum and signal analyzer measurements and noise," Agilent Technol., Santa Clara, CA, USA, 2012 [Online]. Available: <http://cp.literature.agilent.com/litweb/pdf/5966-4008E.pdf>.