

THESIS FOR THE DEGREE OF LICENTIATE OF ENGINEERING

Operability Considerations for Retrofit Design of  
Industrial Process Energy Systems

SOFIE MARTON

Department of Space, Earth and Environment

CHALMERS UNIVERSITY OF TECHNOLOGY

Gothenburg, Sweden 2018

Operability Considerations for Retrofit Design of Industrial Process Energy Systems  
SOFIE MARTON

© SOFIE MARTON, 2018.

Department of Space, Earth and Environment  
Chalmers University of Technology  
SE-412 96 Gothenburg  
Sweden  
Telephone + 46 (0)31-772 1000

Printed at Chalmers Reproservice  
Gothenburg, Sweden 2018

Operability Considerations for Retrofit Design of Industrial Process Energy Systems  
Sofie Marton  
Department of Space, Earth and Environment  
Chalmers University of Technology

## **ABSTRACT**

---

Energy efficiency is crucial to reduce fuel usage and related emissions in industry. In energy-intensive process industry, the use of heat accounts for a large share of the total energy use and a reduction of the heating and cooling demand is thus important for decreasing energy use. Reductions in heating and cooling demand can be achieved by increased heat integration through heat exchange within the industrial process. However, this often increases the number of process interconnections, which can lead to operability issues, which could potentially be a barrier for implementing the heat integration measures. To better estimate the potential for energy efficiency through heat integration and to enable the implementation of more heat integration measures, an open inventory mapping is needed to clarify which operability considerations are important to include in such analyses.

This thesis presents an investigation of operability considerations for heat integrations retrofit proposals. The study is based on a theoretical framework, a qualitative evaluation and a model-based analysis of the consequences for operation of the process utility steam system. The theoretical framework was developed through a literature review and an analysis of possible operability effects through process implications resulting from increased heat integration. This framework was used to design heat exchanger network retrofit proposals that included selected operability issues at a case study oil refinery. The retrofit proposals were evaluated in an interview study with engineers at the oil refinery. The effect of the retrofit proposals on the steam system was analysed using a steam system model.

The results indicate that it is valuable to take process aspects into consideration at an earlier design stage when designing heat exchanger network retrofits for increased heat integration. If operability, non-energy benefits, practical implementation issues and utility systems are considered in an early design stage, several issues can be avoided and large benefits could be achieved for the process.

Key words: Heat integration, Operability, Steam System, Implementation, Non-energy benefits, Interviews

## LIST OF PUBLICATIONS

---

The following papers are included in this thesis:

Paper I – Marton, S., E. Svensson and S. Harvey (2016). *Investigating Operability Issues of Heat Integration for Implementation in the Oil Refining Industry*. In proceedings of ECEEE Industrial Efficiency, Berlin, Germany, September 12-14, 2016.

Paper II – Marton, S., E. Svensson and S. Harvey. *Operability and Technical Implementation Issues Related to Heat Integration Measures – Interview Study at an Oil Refinery in Sweden*. Submitted to *Frontiers in Energy Research*.

Paper III - Marton, S., E. Svensson, R. Subiaco, F. Bengtsson and S. Harvey (2017). *A Steam Utility Network Model for the Evaluation of Heat Integration Retrofits - A Case Study of an Oil Refinery*. *Journal of Sustainable Development of Energy Water and Environment Systems- JSDEWES* 4(4): 560-578.

### **Co-authorship statement**

Sofie Marton (SM) is the main author for all papers included in the thesis. Elin Svensson (ES) and Simon Harvey (SH) supervised the work and provided critical feedback on all paper draft manuscripts. SM, ES and SH discussed the research continuously during the work for all papers included in the thesis. For Paper III, Riccardo Subiaco (RS) and Fredrik Bengtsson (FB) collected process data and RS developed the computational model used in the work.

### **Related papers not included in the thesis:**

Marton, S., E. Svensson, R. Subiaco, F. Bengtsson and S. Harvey (2016). *A Steam Utility Network Model for the Evaluation of Heat Integration Retrofits - A Case Study of an Oil Refinery*. In proceedings of 2<sup>nd</sup> SEE SDEWES Conference, Piran, Slovenia, June 15-18, 2016.

# TABLE OF CONTENTS

---

|  |     |
|--|-----|
| Abstract .....   | III |
| List of publications .....   | IV  |
| Table of Contents .....  | V   |
| Chapter 1 - Introduction .....   | 1   |
| 1.1 Aim and objectives .....   | 4   |
| 1.2 Appended papers .....  | 4   |
| Chapter 2 - Background and related literature .....  | 7   |
| 2.1 Heat integration analysis and operability considerations .....                                       | 7   |
| 2.2 Impact of energy efficiency measures on steam utility system balances .....                          | 9   |
| 2.3 Operability .....  | 10  |
| Chapter 3 - Operability - Proposed definition and categorization.....                                    | 11  |
| Chapter 4 - Industrial case study plant.....   | 13  |
| 4.1 Refinery main energy balances.....   | 13  |
| 4.2 Steam utility system.....  | 14  |
| 4.3 Process units considered in this work and related energy targets.....                                | 17  |
| Chapter 5 - Framework for assessment of operability issues related to heat integration.....              | 19  |
| 5.1 Inventory of possible process operability implications related to heat integration<br>measures ..... | 20  |
| 5.2 Conceptual design of heat integration retrofit proposals.....  | 21  |
| 5.3 Evaluation of impact on steam balances.....  | 23  |
| 5.4 Interview procedure .....  | 24  |
| Chapter 6 - Results .....  | 27  |
| 6.1 Practical considerations .....   | 30  |
| 6.2 Operability .....  | 30  |
| 6.3 Steam system consequences .....  | 32  |
| 6.4 Non-energy benefits .....  | 34  |
| Chapter 7 - Discussion .....   | 35  |
| Chapter 8 - Conclusions .....  | 37  |
| Chapter 9 - Future work .....  | 39  |
| References .....   | 41  |

List of Abbreviations.....47  
Acknowledgements .....49  
Appendix .....51  
    Interview template translated to English .....51  
    Interview template - Swedish original.....53

# CHAPTER 1

## - INTRODUCTION

---

There is a pressing need to decrease greenhouse gas emissions. International and national reports on energy and emissions confirm the excess use of fossil fuels [1, 2] and political climate initiatives such as the Paris agreement [3] and the European 2030 Climate & Energy framework [4] stress the urgency of the climate issue. Increased energy efficiency will be crucial to reach climate targets and in June 2018, a political agreement was reached about a binding energy efficiency target for the EU for 2030 of 32.5% improvement compared to projections made in 2007 [5]. Industry accounts for 38% of energy usage in Sweden [2] and 32% of Sweden's total greenhouse gas emissions [6]. Consequently, industry must play a major role in reaching national energy efficiency targets of reducing the energy intensity by 20% between 2008 and 2020 [7] and the goal of reducing greenhouse gas emissions with 40% by 2020 compared to emissions levels in 1990 [8]. Although the potential to increase energy efficiency in industry is high, there is a gap between the techno-economic potential for energy efficiency and the actual energy efficiency achieved through implementation of energy efficiency measures. This is known as the energy efficiency gap [9].

The energy efficiency gap can be explained by barriers to energy efficiency, and there are many studies that investigate both barriers to and drivers for energy efficiency. One of several possible explanations for this gap is how energy management is implemented, i.e. the operation and planning of energy within a company. Johansson and Thollander [10] present a review of barriers to and drivers for energy efficiency in Swedish industry and identify several success factors connected to energy management, e.g. top-management support, long-term energy strategy and staff training. An investigation of drivers for energy efficiency in manufacturing firms presented by Solnordal and Foss [11] highlight the importance of in-house management rather than governmental policies. Fleiter et al. [12] stress the importance of distinguishing between different types of energy efficiency measures (EEM) when discussing barriers for energy efficiency. For example, technological aspects, such as risk of production disruption, appear to be amongst the most important barriers when the EEM can affect the core process (see e.g. Thollander and Ottosson [13], Rohdin et al. [14] and Dieperink et al. [15]). In contrast, Fleiter et al. [12] discuss an example where production risks are ranked as least important when the core process is not affected (see Anderson and Newell [16]). Cagno and Trianni [17] also address the importance of considering barriers for specific EEMs, rather than assuming that barriers are the same for different technologies.

EEMs usually entail several Non-Energy Benefits (NEBs), also known as co-benefits, which could increase the motivation to implement EEMs. NEBs refer to benefits other than the direct

energy cost savings from the energy efficiency improvement, e.g. reduced carbon dioxide emissions, increased productivity and better work environment [18]. Several studies highlight the importance of considering NEBs. Pye and McKane [19] present a study in which they quantify NEBs for industrial examples of EEMs. They show that the inclusion of NEBs when evaluating EEMs can have a significant positive effect on the economic evaluation and thereby increase the likelihood of an EEM to be implemented. However, the economic value of many NEBs are not easily quantified, e.g. health, social and environmental benefits. Trianni et al. [20] discuss the importance of NEBs of EEMs in small and medium enterprises (SMEs) in northern Italy. Rasmussen [21] suggests to categorise NEBs based on their time frame and quantifiability, in order to facilitate systematic inclusion of the NEBs that can be quantified in economic evaluations of EEMs.

Previous research has shown the importance of considering drivers and barriers for energy efficiency in order to evaluate technical and economical potentials for energy efficiency and to enable higher implementation rates for EEMs. Several studies emphasize that barriers and NEBs differ depending on both the type of industry and the type of measure. This implies that research is needed in different kinds of industry to thoroughly evaluate the potentials to increase energy efficiency in industry and investigate which factors affect the potential to implement EEMs. Much research has been conducted concerning drivers and barriers in SMEs, but with a few exceptions (see e.g. Brunke et al. [22], Johansson and Thollander [10], Thollander and Ottosson [13] and Arens et al. [23]), less research has focused on energy-intensive industry, especially the petrochemical process industry. One example of research focused on energy efficiency in the petrochemical industry is Méchaussie [24], who presents a methodology applied to 10 different petrochemical sites, where process requirements are included in the energy targeting for heat integration measures.

In energy intensive process industry, large amounts of heat are used. Consequently, a more efficient use of heat is essential in order to meet climate targets and increase energy efficiency in this type of industry. Heat integration refers to the recovery of excess heat from parts of the process for use in other parts of the process through a heat exchanger network (HEN), thereby decreasing the need for heating and cooling utilities. To evaluate the techno-economic potential for increased energy efficiency through increased heat recovery, a better estimation of the feasibility of heat integration measures is necessary as well as a better understanding of the drivers and barriers affecting the implementation potential. Since heat integration is closely connected to the core process of industrial plants, both process and energy perspectives should be considered when retrofitting HENs for increased heat integration. Consequently, there are reasons to assume that technical aspects are important barriers for implementation of heat integration retrofits and should therefore be considered early in the screening process of energy efficiency options. This is crucial to enable a rapid screening process of energy efficiency measures and to be able to estimate technical and economical potentials of heat integration.

Rebuilding an existing industrial plant to increase heat integration affects the process in several ways. Because of the complexity of assessing all system consequences, comprehensive process data and a thorough energy analysis is needed to design and evaluate retrofit proposals. For example, it is not obvious how changes in the hot and cold utility use can affect the utility system balances for the total site. One implication of increased heat integration is the increased number of interdependencies between different parts of the process. In previous studies it has been repeatedly discussed that operability is strongly connected to the number of interdependencies within a process, and that interconnections increase the risk for operability or control problems [25-27]. In energy-intensive process plants, production disruptions can be extremely costly and must be avoided. This underlines the importance of considering operability of heat integration measures at an early stage when investigating retrofits of industrial energy systems. Operability issues are usually included in the pre-feasibility or feasibility study phases of the decision-making process, see Figure 1. Therefore it is important to know which operability factors that are most important to consider to enable inclusion of those operability factors in the techno-economic evaluation.

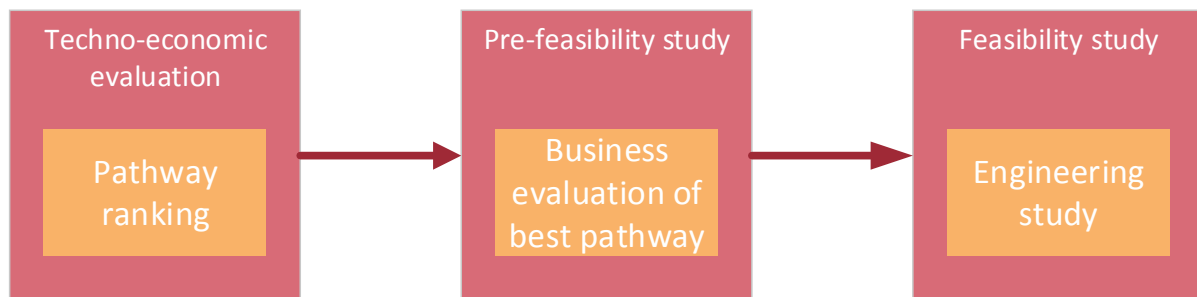

Figure 1. Decision-making process for process development projects.

Operability includes different operational aspects of a process, such as flexibility, controllability, reliability, availability and start-up and shut-down of the process (see Section 2.3 for literature on operability and Section 2.1 for literature on operability consideration of heat integration). It is imperative that operational issues are considered when planning changes to an industrial process. For example, if a process is not flexible it cannot adapt to different operating scenarios, such as varying feedstock, product market prices and weather conditions. Equipment reliability/availability issues can cause expected and unexpected operational disruptions and controllability problems can lead to major safety issues and production disruptions. Therefore, it is important to investigate how heat integration retrofit proposals can affect operability. Furthermore, heat integration can also improve operability, for example by de-bottlenecking, leading to valuable NEBs for the process.

Since heat integration constitutes an important opportunity for potentially large energy efficiency improvements in energy-intensive industry, it is important to be able to derive better estimations of the heat savings potentials. One important aspect in such an analysis is to identify which barriers and drivers have a significant influence on the potential to implement heat integration measures. As discussed above, process operability considerations are essential to consider in this context. Although many studies have investigated specific aspects of operability (see Paper I and Chapter 2), there is very little literature available that systematically investigates the impact of process operability factors on the selection of HEN retrofit measures for implementation.

## **1.1 AIM AND OBJECTIVES**

This thesis aims to map, discuss and clarify the connections between heat integration and operability. This is achieved theoretically through a literature review, qualitatively through an interview study and quantitatively through design of heat integration measures at a large oil refinery in Sweden and quantification of their impact on the steam system using a purposely built model. The oil refinery selected for the study is a complex, interconnected process plant suitable for mapping and investigating a wide variety of operability issues. Heat integration retrofit proposals for selected refinery process units were designed to include features that could potentially affect the operability of the process. The retrofit proposals are used as a basis for the interview study and steam system evaluation.

The objectives of this thesis are to:

- Provide an overview of published research literature related to definitions of operability and connections between operability and heat integration measures.
- Propose a definition of operability and its sub-categories suitable for the purpose of the work.
- Develop a theoretical framework to connect specific features of heat integration measures with potential process operability and technical implementation issues.
- Conduct a qualitative evaluation and map operability considerations for specific HEN retrofit proposals for a case study industrial site.
- Analyze fuel and steam system effects of selected retrofit proposals.

## **1.2 APPENDED PAPERS**

The following papers are the basis for the work presented in this thesis:

Paper I – Marton, S., E. Svensson and S. Harvey (2016). *Investigating Operability Issues of Heat Integration for Implementation in the Oil Refining Industry*. In proceedings of ECEEE Industrial Efficiency, Berlin, Germany, September 12-14, 2016.

Paper II – Marton, S., E. Svensson and S. Harvey. *Operability and Technical Implementation Issues Related to Heat Integration Measures – Interview Study at an Oil Refinery in Sweden*. Submitted to *Frontiers in Energy Research*.

Paper III - Marton, S., E. Svensson, R. Subiaco, F. Bengtsson and S. Harvey (2017). *A Steam Utility Network Model for the Evaluation of Heat Integration Retrofits - A Case Study of an Oil Refinery*. *Journal of Sustainable Development of Energy Water and Environment Systems- JSDEWES* 4(4): 560-578.

Paper I investigates definitions of the term operability in the literature. Paper I also proposes a definition of operability as well as sub-categories of operability that are suitable for the objectives of this thesis. In particular, Paper I connects features of specific heat integration retrofits to operability factors that are likely to be affected by the specific feature. Paper II investigates and maps operability issues through an interview study at a large oil refinery in Sweden. The results from Paper I are used in Paper II as a theoretical base to design HEN retrofit proposals that include different potential operability issues, which were discussed with refinery staff in 11 semi-structured interviews. Paper III analyses the steam and fuel system consequences for the HEN retrofit proposals in Paper II by a simulation model built in Aspen Utilities Planner.

The connections between the papers and their respective connections with the designed HEN retrofit proposals are shown in Figure 2.

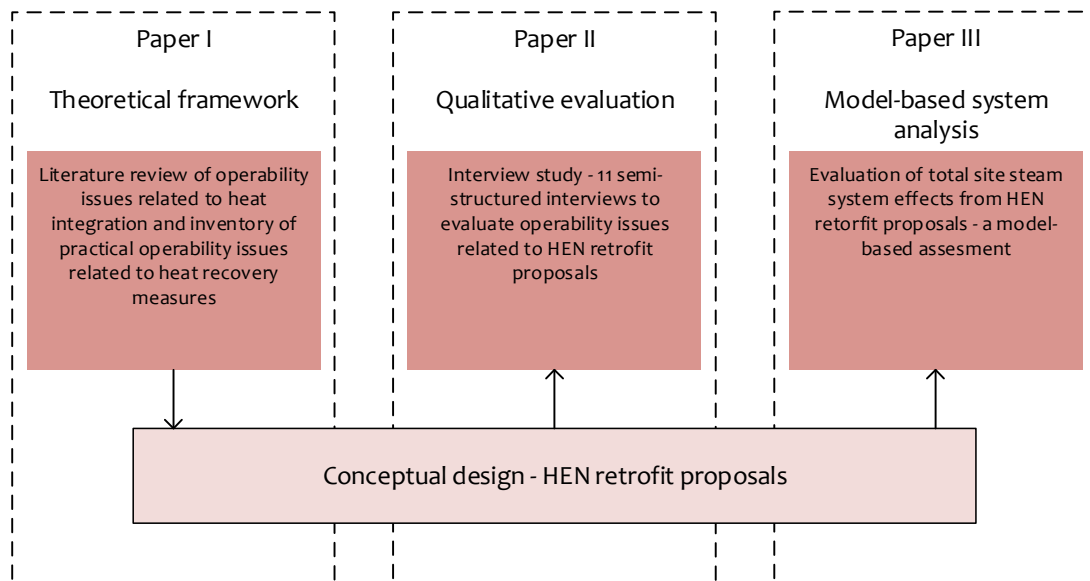

Figure 2. Overview of appended papers.



# CHAPTER 2

## - BACKGROUND AND RELATED LITERATURE

---

This chapter presents a review of previous studies of heat integration retrofits connected to operability and implementation issues, steam system modelling and process operability definitions. A more comprehensive discussion regarding current literature related to operability of heat integration can be found in Paper I.

### 2.1 HEAT INTEGRATION ANALYSIS AND OPERABILITY CONSIDERATIONS

Heat integration analysis can be used to obtain an overview of the heat and cooling demands of an industrial process as well as the heat savings potential. One common method for analysing heat integration opportunities is pinch analysis (see e.g. Kemp [28] or Klemeš [29]). Pinch analysis can be used to establish process energy targets, which are dependent on the minimum allowable temperature difference for heat exchange between process streams ( $\Delta T_{\min}$ ), and which should be selected to represent a suitable balance between investment costs and energy cost savings. Since heat transfer properties vary for different fluids, individual  $\Delta T_{\min}$  contributions are often chosen for process and utility streams. Pinch analysis establishes the location of the process pinch point temperature which divides the heating and cooling demands into a region of heat deficit (above the pinch temperature) and a region of heat excess (below the pinch temperature). Pinch rules for heat exchanger network design state that (i) heat should not be removed from the process above the pinch; (ii) heat should not be supplied to the process below the pinch; (iii) heat should not be transferred from above to below the pinch. Violation of these rules will result in heating and cooling demands that exceed the energy targets. In an existing network, it is possible to locate all pinch rules violations, which provides valuable insights about where to focus efforts to improve process energy efficiency [28, 29].

A wide variety of published case studies have shown that substantial increase of energy efficiency can be achieved by retrofitting existing Heat Exchanger Networks (HENs) at industrial process sites. There exist a number of different methodologies to identify HEN retrofit designs that could achieve high energy savings at low cost, each of which has its own benefits and drawbacks. It is common that several HEN designs can be identified that achieve approximately the same energy saving at similar costs. However, such HEN designs can vary significantly regarding network complexity, placement of new heat exchangers as well as utility heaters and coolers for target temperature control, etc. It is thus clear that technical and operational factors need to be considered together with investment cost and fuel cost savings when assessing HEN retrofit options.

There are many different methodologies for retrofitting HEN for increased heat integration and energy efficiency, see for example Sreepathi and Rangaiah [30] for a review of HEN retrofit methodologies and applications. More recent developments of HEN retrofit methods that take different process and practical issues into consideration include, for example, mixed integer linear programming (MILP) based approaches to make good heat exchanging choices at the early design stage [31], graphical optimization methods to take both HEN and reactor optimization into account [32] and MILP models that include heat exchanger geometry, pressure drops, temperature differences, by-pass and splitting of process streams [33]. Klemeš et al. [34] present a comprehensive review of implementation in pinch methodology. The authors present several applications of pinch methodology, including total site integration and heat integration retrofits. Although their review includes 340 references, operability is not mentioned, which indicates that there is a lack of studies related to this topic.

Operability issues are traditionally not considered in the conceptual design phase. As previously mentioned, a common approach in HEN retrofit studies is to identify pinch rules violations in the existing HEN, and thereafter attempt to remove or reduce such violations starting with the largest violation. At this early design stage, it is unusual to consider costs other than utility costs. Methods have been proposed to account for some of the aforementioned practical and operability considerations in network design. For example, Becker and Maréchal [35] present a method to consider heat exchange restrictions using mixed integer linear programming. Ulyev et al. [36] show an example of retrofitting HEN at an oil refinery including practical restrictions in the design such as spatial limitations and limited time slots during major turn-arounds. Practical considerations and associated costs are especially important when considering integration at large sites or even across company boundaries which is the case, for example, for piping and pressure drops (see e.g. Hiete et al. [37], Polley and Kumana [38], Cerda and Westerburg [39]). Escobar et al. [40] suggest a framework that includes controllability and flexibility in HEN synthesis. Hackl and Harvey [41] suggest a method that excludes unpractical heat exchanging options identified by plant engineers for a total site analysis for a chemical cluster in Sweden. Nemet et al. [42] suggest a total site synthesis that takes fluctuating utility prices into account. Several authors have used MILP for multi-period optimization to combine process integration with operational aspects such as operability and flexibility [43-45]. Abu Bakar et al. [46] suggest including operability in addition to investment and utility cost savings in the choice of  $\Delta T_{\min}$  for HEN design by including flexibility and sensitivity analysis in the choice of  $\Delta T_{\min}$ .

Although many studies have taken different operability and technical implementation issues into account, there is very little literature available that systematically investigates which factors are most important to consider when screening candidate HEN retrofit measures with the goal of identifying the measures that are most likely to be implemented.

## **2.2 IMPACT OF ENERGY EFFICIENCY MEASURES ON STEAM UTILITY SYSTEM BALANCES**

When evaluating energy savings in large, complicated processes, it is important to consider the entire energy system. Energy savings that can be achieved in one process unit might not achieve the same savings when the total site is considered. For example, if utility steam is saved at one part of the plant, but a large excess of steam is produced at another process unit, the saving will not result in any fuel savings.

Steam is usually available in several steam headers with different pressures to provide heat at various temperature levels. The generation of steam can also be used as a cooling agent in steam generators where water is evaporated through heat exchange with a hot process stream. A central heating system, such as a steam utility system, provides the opportunity to transfer heat throughout the industrial site, especially if heat sources and heat sinks are located far apart and direct process-to-process heat exchange would not be feasible. This increases the flexibility of the process and the heating system. Steam headers are connected through turbines and let-down valves. Changes in steam consumption and/or production at one header can therefore affect the steam balances at other pressure headers in the system. The importance of considering the effect on the entire steam system balances when making changes to the steam balance of a specific steam header through energy conservation projects has been demonstrated by Sun et al. [47], who also calculated a marginal economic value of steam savings using a detailed steam system optimization model.

Furthermore, since process conditions constantly change with ambient conditions, raw material and product mixes, the steam consumption/production is not constant. Since all components in the steam system are connected at the different levels, they are strongly dependent on each other [48]. This means that the operation of other steam system components, such as steam boilers and steam turbines, must be adjusted according to the variations in steam consumption/production caused by the process variations. In addition to variations within the industrial plants, variations in fuel and electricity prices also affect the optimal operation of the steam system [49]. The large number of interdependencies and sources of variations makes the system complicated and makes it difficult to analyse the energy consequences of heat integration projects without including modelling of the steam system in the analysis. Each heat integration retrofit measure that implies a modification to the steam utility balances requires a complex decision on the best operational response for the overall steam system [50].

During recent years, models for simulation and optimization of steam utility systems have been developed to include various aspects of steam system operation such as seasonal variations [51], environmental and economical optimization [52], availability and reliability considerations [53] and operational decisions [54]. Micheletto et al. [55] present a case study in which utility system operation at an oil refinery is optimized for various operating conditions. Several other case studies for steam utility systems have been conducted, for example, Ruiz and Ruiz [56] summarize 20 years of experience of real time optimization at various industrial sites.

## 2.3 OPERABILITY

The definition of operability varies in the literature and is related both to chemical engineering in general and heat integration in particular. Escobar et al. [40] summarize many of the interpretations of operability and relate them to HEN design and define operability as follows:

*“The term operability is often referred to with which a process can be operated and controlled. It includes both flexibility and controllability, and is strongly affected by the network design.”*

Setiawan and Bao [26] also discuss the importance of process design connected to operability and describe operability as a key to analyze the network design and the control system simultaneously. Operability is often connected to process control and degrees of freedom of the process as well as the number of interdependencies within a process [25-27, 57]. Other than the close link between operability and controllability, flexibility is frequently described as an important characteristic of operability and in some cases operability is described as a characteristic of flexibility [58]. For example, Aguilera and Nasini [59] use a definition of flexibility from Cerda et al. [60] and connect it to HENs

*“...a heat exchanger network (HEN) is structurally flexible for a given range of variation of parameters, if it guarantees operability (feasibility) and maximum energy recovery between process streams.”*

Other than describing operability in terms of more narrow concepts such as controllability or flexibility, operability can also be defined more generally as the ease of operating a process at steady state and dynamic conditions [40, 61-64]. In many cases, however, it is useful to divide operability into sub-categories to clarify its definition. Marlin [64] underlines the importance of including operability in chemical engineering education and proposes distinguishing different operability aspects including operating window, start-up and shutdown, variable operating conditions, turndown requirements, controllability and operational hazards. Chew et al. [65] discuss practical implementation issues related to heat integration in total sites and divide operability into operating window, flexibility and controllability, reliability, safety, efficiency, operation during transition, dynamic performance and monitoring and diagnosis.

# CHAPTER 3

## - OPERABILITY - PROPOSED DEFINITION AND CATEGORIZATION

---

In this work the following definition of operability is proposed:

*Operability is the ability to operate equipment, process units and total sites at different external conditions and operating conditions, without negatively affecting safety or product quality and quantity. This includes both steady-state and dynamic aspects of operation.*

Furthermore, the following subcategories are proposed: Flexibility, Controllability, Start-up/Shut-down, and Reliability/Availability, which are described hereafter.

Practical considerations should also be included in addition to operability. They are a crucial part of implementing heat integration measures and of rebuilding a chemical process [30], although they are not covered by the operability definition proposed above.

An overview of possible implementation issues related to operability and practical considerations is shown in Figure 3. These aspects and their proposed definitions are discussed further below.

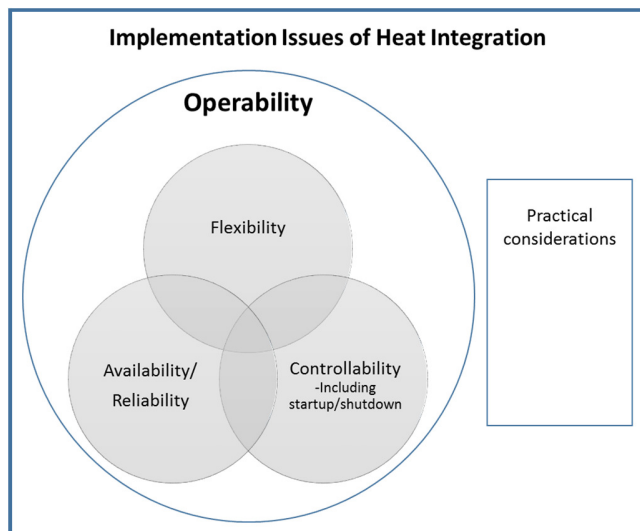

Figure 3. Relations between operability factors, operability and practical considerations.

- **Flexibility:** A flexible process is able to operate for different operating scenarios. For oil refining processes, flexibility includes, for example, being able to handle different crude oil feedstock types, product mix requirements and ambient conditions. Flexibility also includes the ability to handle long-term variations within the process, such as decreased reactivity in catalyst beds and decreased heat transfer due to fouling.
- **Controllability:** Controllability is defined as the ability to maintain stable process operation, while handling disturbances and short-term variations to the process. In the definition proposed in this thesis, controllability also includes being able to maintain a stable process during transition from one operating scenario to another.
  - **Start-up/shut-down:** Feasibility of start-up/shut-down transitions is defined as the ability for the process to be able to start-up/shut-down in a controlled and safe procedure. Due to the special characteristics of start-up/shut-down transitions, this is important to consider separately, although it is essentially included in the definition of controllability.
- **Reliability/availability:** In this thesis, reliability and availability are grouped together. This is because both concepts are connected to equipment or process failure and both have similar operability implications for the process. Reliability is defined as the ability to operate a process without unexpected equipment failure. Availability, on the other hand, is the expected operating time for equipment during a time period that also includes planned maintenance [53].
- **Practical considerations:** To be able to implement retrofits of HENs, practical/technical issues other than the operability issues defined above need to be considered [30]. For example, the plant needs to have space for new equipment and for its maintenance. There also needs to be time to implement the process rebuild, which for most of the measures considered needs to be scheduled during expensive turnaround periods.

Process safety is not included as a separate category. This is because safety aspects relevant for this study are included in the other categories. For example, poor control of the inlet temperature to a reactor could lead to thermal runaway of exothermic reactions. Safety is closely related to controllability and equipment malfunctions. Economic aspects are obviously very important for the implementation possibilities of heat integration projects, and are furthermore tightly related to most technical issues. Moreover, the focus of the study are the technical aspects and not the economic aspects although they are tightly connected. The economic aspects are therefore not included as a separate category in this thesis.

# CHAPTER 4

## - INDUSTRIAL CASE STUDY PLANT

---

Large industrial process plants include many interconnected process units and extensive utility systems. A comprehensive data collection and analysis is essential to obtain the details necessary to identify candidate HEN retrofit measures and their related operability aspects. In this work, a single industrial oil refinery site was investigated in detail, which provided the opportunity to design HEN retrofits (see Section 5.2) that include many of features related to different aspects of operability and to discuss the retrofits in depth with refinery staff. Choosing only one plant also provided the opportunity to collect utility steam system data and model the steam system. This level of detail would not have been possible if several plants had been included in the study. The case study was conducted at one of West Europe's most energy-efficient complex oil refineries, with a Solomon energy intensity index of 84 compared to the median of 94.5 for West Europe Refineries [66]. The studied refinery has a crude oil processing capacity of 11.5 million tonnes per year and total CO<sub>2</sub> emissions of 1.6 million tonnes in 2017 [2]. The main products are petrol, diesel, propane, propylene, butane and bunker oil.

### 4.1 REFINERY MAIN ENERGY BALANCES

The heat demand of the refinery is satisfied mainly by direct heating in process furnaces and by utility steam that is produced in steam boilers, flue-gas heat recovery boilers and process coolers. Figure 4 shows the main refinery material and energy flows. The so-called refinery gas, which is the main fuel both in process furnaces and steam boilers, consists of the non-condensable gases from the refinery distillation columns and contains lighter petroleum products such as hydrogen, methane and ethane, but also small amounts of valuable products (such as propane and butane). Since the distillation units are equipped with an air cooling system, the amount of products that can be condensed depends on the ambient air temperature as well as the crude oil composition and target product mix. At low ambient temperatures, more valuable liquid products can be obtained, with the result that less refinery gas is obtained. When the amount of refinery gas is not sufficient to cover the heat demand of the refinery, purchased Liquefied Natural Gas (LNG) is used as make-up fuel in the steam boilers and process furnaces. Alternatively, liquid products such as propane and butane can be vaporized and used as a make-up fuel.

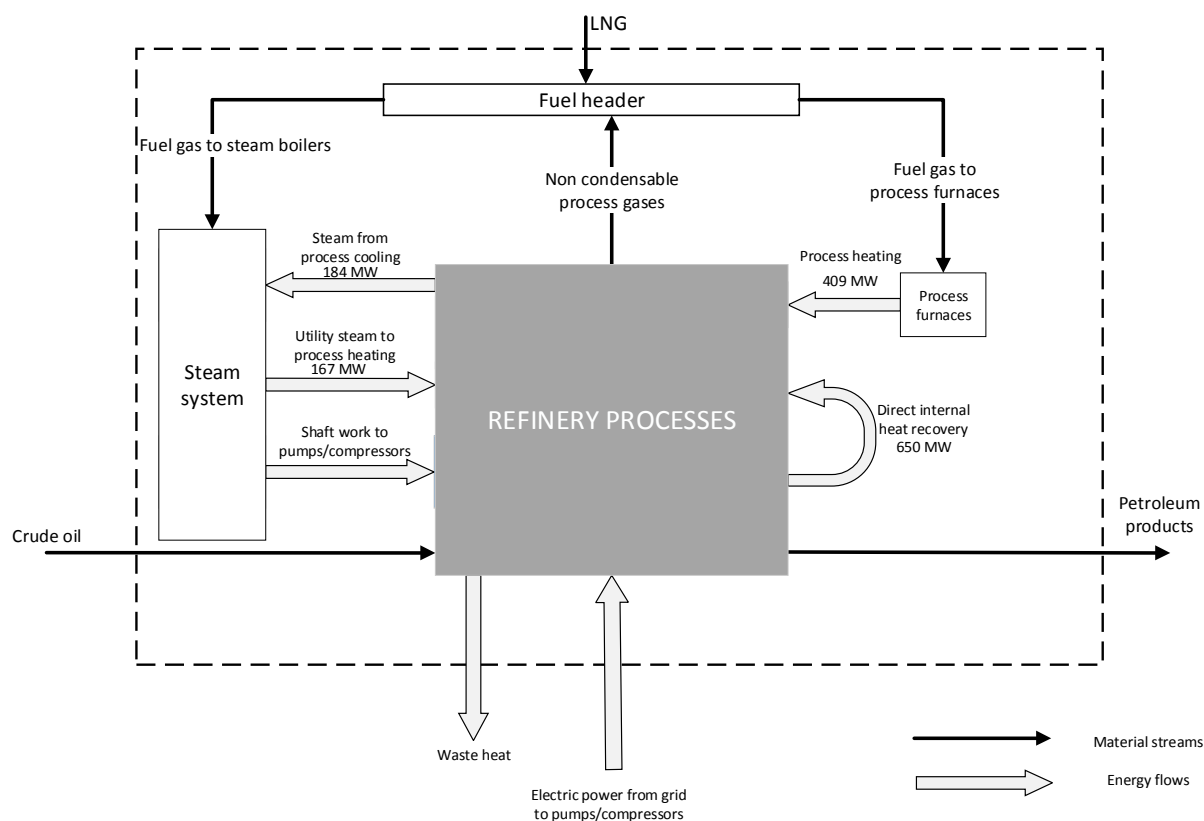

Figure 4. Major refinery material and energy flows. Process heating and cooling data were collected for pinch analysis purposes. More comprehensive data for the steam system were collected for different operating points, as described in Paper III.

In previous projects in the author's research group, energy targeting and retrofit studies were carried out for the case study refinery [67, 68]. In these studies, process stream temperatures and heat load data were collected for most of the refinery heat exchangers. Process stream data were collected on April 23<sup>rd</sup> 2010 from production data screen dumps and data logs. The date was chosen in collaboration with refinery engineers to represent stable full capacity operation. For these operating conditions, the process hot utility demand that was covered by process furnaces was determined to be 409 MW [67]. Minimum utility requirements were determined for the different process units using pinch analysis. Details about the results of this energy targeting are presented in Section 4.3.

## 4.2 STEAM UTILITY SYSTEM

Steam is used as a heat source in heat exchangers and injected into fractioning columns, as well as to produce mechanical work in turbines to drive pumps and compressors. The steam network at the refinery, shown in Figure 5, consists of four main pressure levels: Very High Pressure (VHP), High Pressure (HP), Medium Pressure (MP) and Low Pressure (LP). VHP steam is

mainly produced in steam boilers and waste heat boilers that recover heat from process furnace flue gases. The other steam headers are fed by steam generated in process coolers and steam from turbines and valves from higher pressures.

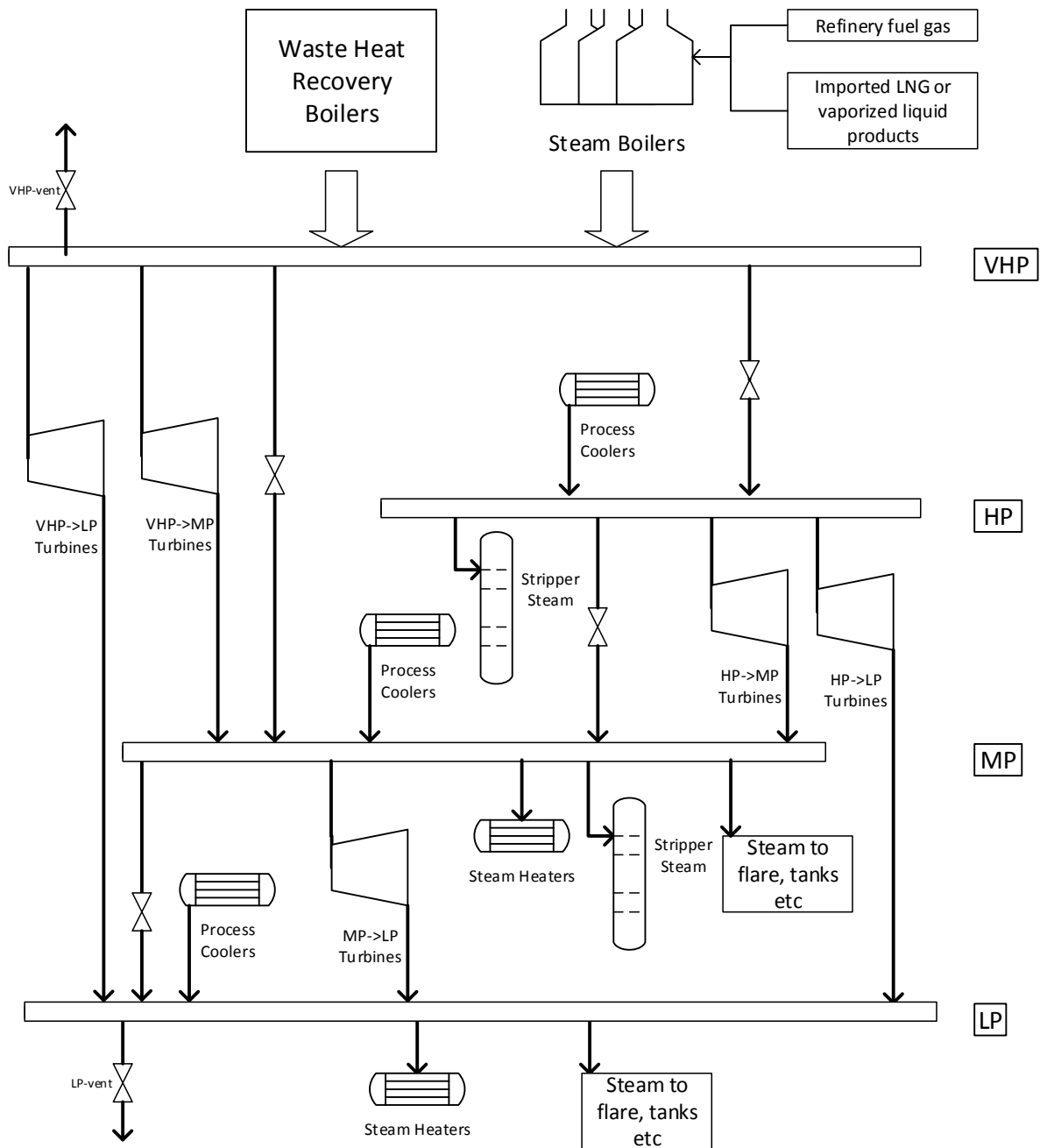

Figure 5. Steam system overview.

As discussed in Section 4.1, when the outside air temperature is high, less condensable products and more refinery off-gases are obtained. Prolonged flaring of refinery off-gas is prohibited due to environmental regulations. Consequently, the excess refinery off-gas, is fired in the steam boilers even if the steam produced is not needed. Excess steam can be vented in limited amounts, if necessary, but to avoid a large excess of steam in such situations, the waste heat boilers can be turned off, thereby releasing hot flue gases from process furnaces to the atmosphere at high temperature, with a big energy loss.

The steam headers are interconnected by let-down valves and turbines, the latter used in direct drive configuration to operate more than fifty compressors and pumps. With the exception of the HP level, which is a local header recently built only to supply steam to a newly built hydrocracker unit, the main headers are extended throughout the entire refinery. The flows through let-down valves between the steam headers (and to the LP vent) are automatically controlled to maintain the set-point pressures of the headers. Manual operator decisions can be made to turn on or off various turbines in the network that drive pumps and compressors, which can be switched between steam turbine drive and electric motor drive (see Figure 6). There is no electric power generation on site.

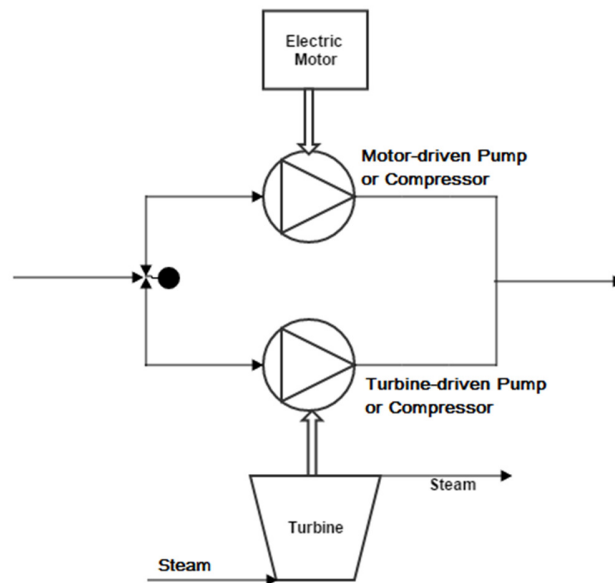

Figure 6. Configuration of switchable pumps and compressors.

### 4.3 PROCESS UNITS CONSIDERED IN THIS WORK AND RELATED ENERGY TARGETS

Previous pinch analysis studies showed that five refinery process units account for 90 % of the current hot utility use and also have the greatest potentials for heat savings [67, 68]. Of the five process units, one has been rebuilt since the data was collected and pinch analysis targeting was conducted. Therefore, the remaining four units with high heat-saving potentials were chosen for this study. The four units chosen are Naphtha Hydrotreating Unit (A), Catalytic Reforming Unit (B), Mild Hydrocracking Unit (C) and Hydrocracker Unit (D). To be able to investigate operability aspects of heat integration between process units, two units located close to each other were grouped together. Actual heat usage and minimum heat demand for the chosen units are displayed in Table 1. The analysis – and design – was conducted for one single operating point, which represents normal operation for the refinery. It should be noted, however, that process operation and ambient conditions vary over time.

*Table 1. Current heat usage and corresponding minimum heat demand for process units included in this paper. For the pinch analysis, the following minimum temperature differences contributions ( $\Delta T_{min}/2$ ) were considered; 10 K for condensing/boiling hydrocarbons, 5 K for water, 2.5 K for boiling water and 15 K for other process streams.*

| <b>Unit</b> | <b>Current heat usage (MW)</b> | <b>Min heat demand (MW)</b> |
|-------------|--------------------------------|-----------------------------|
| <b>A+B</b>  | 125                            | 104                         |
| <b>C</b>    | 26                             | 10                          |
| <b>D</b>    | 46                             | 9                           |

In this work, nine HEN retrofit proposals were designed and then discussed during the interview study described in Chapter 5. The proposals were designed to include specific features that were assumed to be related to operability and technical implementation aspects of relevance for the process units considered. In Section 5.1 such features, here denoted process implications, are listed and described in more detail. The HEN retrofit proposals used in the interview study were designed within the selected process units.



# CHAPTER 5

## **- FRAMEWORK FOR ASSESSMENT OF OPERABILITY ISSUES RELATED TO HEAT INTEGRATION**

---

This chapter presents the framework for assessment of operability issues related to heat integration as well as the methods used for the interviews, HEN retrofit design and quantification of the impact on steam system operation.

Although scientific literature is scarce on the subject of operability and heat integration, many experienced engineers and operators in industry possess a deep knowledge and understanding of their processes and the way they operate under various conditions. To be able to tap into this extensive knowledge base, a case study approach based on open interviews was used. As discussed by Sovacool [69, 70], this approach provides a broader perspective as well as a more detailed understanding of process operation compared to using computational models of the process. In a computational model, only known parameters variables can be included. In an open interview study, the included topics are not limited to what is previously known. Since limited research is available about which operability aspects that are most important to consider in a HEN retrofit study, an open-ended interview approach is most suitable so as to be able to capture operability topics that were considered in the initial inventory.

An overview of the methodology used for the interview study is shown in Figure 7. As the figure shows, HEN retrofit proposals were designed for the study (see Section 5.2). The designs were based on a literature review and the analysis of operability perspectives of heat integration measures described in Paper I. The process data for the retrofit proposals were taken from a previous pinch study at the refinery (see Andersson et al. [67]). Steam system impacts resulting from the retrofit proposals were analysed using a simulation model constructed in Aspen Utilities Planner [71] (see Section 5.3). The proposals were discussed with refinery experts in eleven interviews (see Section 5.4). The results were then summarized and presented to the refinery experts again for confirmation and further discussion at a validation seminar.

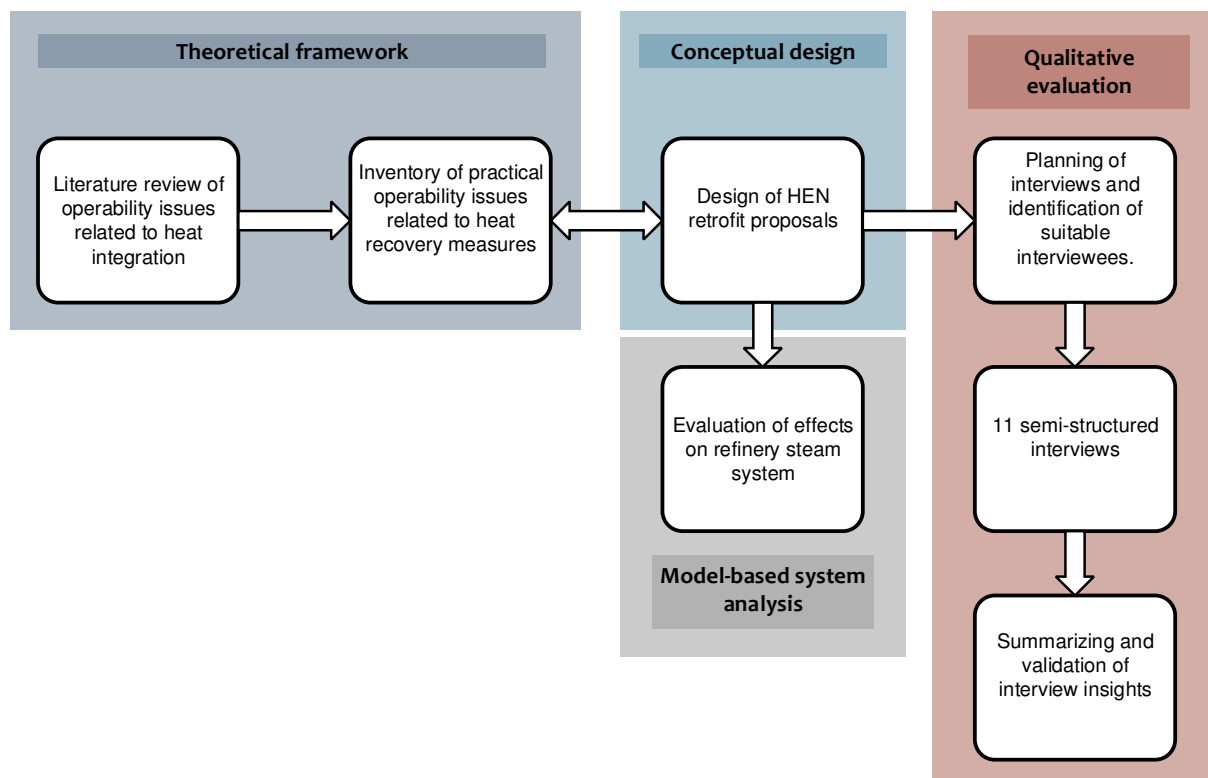

Figure 7. Overview of the workflow for the study.

## 5.1 INVENTORY OF POSSIBLE PROCESS OPERABILITY IMPLICATIONS RELATED TO HEAT INTEGRATION MEASURES

To be able to discuss different aspects of operability in the interviews, a number of heat integration retrofit proposals were designed that cover different process implications related to operability. To ensure an exhaustive coverage of process implications and operability aspects, a list of potential process implications was compiled based on literature examples and experience from previous process integration projects. The selected implications were then matched with the operability factors that were considered most likely to be affected by the respective implication (see Table 2). After the initial round of interviews conducted, the list of possible implications was extended if new implications were identified. For more detailed information about the inventory procedure, see Paper I. Table 2 was also used to formulate the interview questions described in Section 5.4 and Appendix.

Table 2. Implications of heat integration retrofit measures and their connection to operability factors and implementation issues.

| Operability factors and implementation issues<br>Implications of heat integration retrofit measures | Flexibility | Controllability | Start-up/ Shut-down | Reliability/Availability | Practical considerations |
|---|-------------|-----------------|---------------------|--------------------------|--------------------------|
| 1. De-bottlenecking   | X           |                 |                     |                          |                          |
| 2. Stream splitting   |             | X               |                     |                          |                          |
| 3. HEN complexity   | X           | X               |                     |                          |                          |
| 4. Reduced load on a furnace  | X           | X               |                     |                          |                          |
| 5. Reduced load on an air cooler  | X           | X               |                     |                          |                          |
| 6. Increased pressure drop in heat exchangers   | X           | X               |                     |                          |                          |
| 7. Change in steam balance  | X           | X               |                     |                          |                          |
| 8. Shut-down of furnace before reactor  | X           | X               | X                   |                          |                          |
| 9. Heat exchange between process units  | X           | X               | X                   |                          |                          |
| 10. New equipment installation  |             |                 |                     | X                        | X                        |
| 11. Rebuilding existing equipment   |             |                 |                     | X                        | X                        |
| 12. Pressure differences between streams or high pressures  |             |                 |                     | X                        | X                        |

## 5.2 CONCEPTUAL DESIGN OF HEAT INTEGRATION RETROFIT PROPOSALS

The heat integration retrofit proposals were designed based on the pinch analysis study described in Chapter 4. Each retrofit proposal was designed to investigate the effect of some of the specific implications described in Section 5.1. The retrofit proposals were also designed so that all implications are covered, which can be seen in Table 3. All retrofit proposals are described in detail in the supplementary material to Paper II.

Table 3. Mapping of retrofit proposals and associated implications.

| Retrofit Proposal  | Unit A+B |    |    |   | Unit C |    |    | Unit D |   |
|--|----------|----|----|---|--------|----|----|--------|---|
|  | 1A       | 1B | 1C | 2 | 4A     | 4B | 4C | 5      | 6 |
| 1. De-bottlenecking  |          |    |    |   | ■      | ■  | ■  |        | ■ |
| 2. Stream splitting  |          |    |    |   |        |    | ■  |        |   |
| 3. Network complexity                                      |          | ■  |    |   | ■      |    | ■  |        |   |
| 4. Reduced load on a furnace                               | ■        | ■  | ■  |   | ■      | ■  | ■  |        | ■ |
| 5. Reduced load on an air cooler                           | ■        | ■  | ■  |   | ■      |    |    |        |   |
| 6. Pressure drop   | ■        | ■  | ■  |   | ■      | ■  | ■  |        |   |
| 7. Change in steam balance                                 |          | ■  |    |   |        | ■  | ■  | ■      | ■ |
| 8. Shut down of furnace before reactor                     |          |    |    |   |        |    |    | ■      |   |
| 9. Heat exchange between process units                     | ■        | ■  | ■  |   |        |    |    |        |   |
| 10. New equipment installation                             | ■        | ■  | ■  |   | ■      | ■  | ■  |        | ■ |
| 11. Rebuilding existing equipment                          | ■        | ■  | ■  | ■ | ■      | ■  | ■  | ■      |   |
| 12. Pressure differences between streams or high pressures |          |    |    |   |        |    |    | ■      | ■ |

For combined Unit A+B, the main objective was to include heat exchange between two process units (Implication #9) in the retrofit proposals (Retrofit proposals 1A-C and 2). All proposals for Unit A+B include pre-heating feed streams to reduce the load of the same furnace, but with different paths for stream pre-heating. The feed stream pre-heating proposals vary in complexity, increased heat exchanger area requirements and heat source (hot process streams or hot flue gases). Another aspect included in Retrofit proposal 1B is the replacement of utility steam heating of a distillation column reboiler by heating through internal heat exchange with a hot

process stream within the process units. For Unit C, three different ways of increasing the pre-heating of a feed stream to a process furnace were considered. In the first retrofit proposal, 4A, excess heat from other hot process streams currently cooled with air fans is used. An excess of low pressure (LP) steam is available at the refinery during most of the year and the steam is utilized in Retrofit proposals 4B and 4C. In Retrofit proposal 4B, LP steam is used for the feed stream pre-heating, decreasing the number of process interconnections. Retrofit proposal 4C also uses LP steam for pre-heating, but the proposal involves a stream split. For unit D, two retrofit proposals were designed that involve using heat from two different process furnace flue gas streams, leading to a reduction of HP steam production in the waste heat boiler section of the furnaces. The furnace in Retrofit proposal 5 is placed upstream of an exothermic reactor and implies shutting down the furnace during normal operation. Retrofit proposal 6 includes increased pre-heating before another process furnace that is placed before a distillation column. Both Retrofit proposal 5 and 6 also include process streams at high pressures and heat exchangers with large pressure differences between the hot and cold process streams.

### **5.3 EVALUATION OF IMPACT ON STEAM BALANCES**

To be able to evaluate total site effects on refinery steam and fuel balances, a steam model was used for the retrofit proposals that affect the refinery steam balances. For a thorough description of the evaluation, see Paper III.

A complete model of the refinery steam network was created based on measurements within the plant, energy and mass balances, assumptions regarding unmeasured variables, component datasheets and discussions with company employees. Mass and energy balances were established for the entire steam network, including steam production units, steam headers, turbines, valves, and desuperheaters, as well as steam consumers. The components and their connections in the network were modelled in Aspen Utilities Planner [71] with user interfaces connected to Excel spreadsheets. The boilers fuel consumption, the electric power used for the electric-driven pumps, the vented steam and the make-up water were included in the model to allow for a systematic analysis of modifications made to the steam balances. For a detailed description of the original steam utility network model, see Subiaco [72], and for further improvements and development of the same model, see Kobjaroenkun and Gunnarsson [73].

Steam system consequences for retrofit proposals that include changes to steam balances were analyzed for three different operating scenarios for which the refinery had a deficit of refinery off-gas, which is the case during approximately 75% of the year. The scenarios are listed in Table 4. In the table month for the operating points, if the production in steam boilers is normal or low and if there are specific process conditions affecting the steam system are listed. Due to the deficit of refinery gas for all scenarios, LNG is imported. Consequently, a retrofit leading to fuel gas savings will enable a reduction of the LNG import. For the 25% of the year with a refinery off-gas surplus, none of the proposed HEN retrofits will result in fuel savings. The produced refinery gas needs to be combusted, regardless of whether the utility heat is used or not. For this

case, increased steam consumption or decreased steam production in waste heat boilers is beneficial. This makes the steam surplus smaller and thereby reduces the water losses from steam venting.

*Table 4. The three operating scenarios, for which plant measurement data was collected and used for simulation and validation. All three scenarios represent operating points with a deficit of refinery gas, hence LNG is imported.*

| <b>Scenario</b> | <b>Month</b> | <b>Steam production<br/>at VHP level</b> | <b>Comment</b>                             |
|-----------------|--------------|--|--|
| <b>1</b>        | September    | Medium                                   | Main scenario                              |
| <b>2</b>        | April        | Medium                                   | -  |
| <b>3</b>        | May          | Low                                      | Maintenance for some units of the refinery |

#### **5.4 INTERVIEW PROCEDURE**

All interviews in the study were semi-structured interviews that were conducted face-to-face. Having the interviews face-to-face enabled a good communication, for example it provided the possibility to discuss print-outs of flowcharts in detail. Semi-structured interviews were used because of the combination of structure and flexibility [74-76]. To our knowledge, no studies have been published in the literature that use this method for discussing and investigating heat integration retrofit implementation, with interviews focusing on technical aspects. The interviews were conducted with technical staff with significant knowledge about operational and technical aspects of the refinery. Semi-structured interviews provided opportunities to discuss relevant topics in detail, given the flexibility of follow-up questions and discussion during the interviews. By using follow-up questions in addition to the planned questions, any uncertainties in the participants' responses were clarified directly. Most interviews were about one hour long, but there was no time limit. Instead, the topics discussed determined the time for each interview. The interviews were conducted in Swedish and all material was transcribed and translated afterwards.

The interview procedure was the same for operations and process engineers responsible for the process units included in the study. The template for the interview procedure and questions with process and operations engineers is provided in the Appendix. HEN retrofit proposals were shared in advance to give the engineers an opportunity to prepare for questions and check anything uncertain about the affected part of the process unit. The same set-up of open questions was used to discuss all retrofit proposals. The basic questions were complemented with follow-up questions depending on the discussion. Firstly, open questions were asked about the interviewee's thoughts about potential consequences of implementing the retrofit proposal. For all issues that were brought up, solutions were requested and discussed. Following the open questions, more specific questions were asked about operability aspects considered in the design phase of the retrofit proposal. At the end of the interview, the interviewee was asked to list the top three obstacles and grade the retrofit proposal's implementation potential from one (low) to

four (high). The interviews with mechanical engineers, control engineers and the process engineer responsible for the energy system started with a general discussion about their area of expertise related to heat integration. If specific retrofit proposals were discussed, these were sent beforehand. The interviews with mechanical engineers, control engineers, and the process energy engineer also provided an opportunity to verify anything unclear brought up in the previous interviews with operations and process engineers regarding equipment, energy systems or control systems. Table 5 lists the content discussed in each interview.

Table 5. List of interviewees and content discussed in the interviews.

|           | <b>Refinery responsibilities</b>                     | <b>Content discussed</b>  |
|-----------|--|---|
| <b>1</b>  | Operations engineer, Unit A and B                    | <ul style="list-style-type: none"> <li>• Retrofit proposals 1A-C, 2</li> </ul>  |
| <b>2</b>  | Process engineer, Unit A and B                       | <ul style="list-style-type: none"> <li>• Retrofit proposals 1A-C, 2</li> </ul>  |
| <b>3</b>  | Operations engineer, Unit C                          | <ul style="list-style-type: none"> <li>• Retrofit proposals 4A-C</li> </ul>   |
| <b>4</b>  | Process engineer, Unit C                             | <ul style="list-style-type: none"> <li>• Retrofit proposals 4A-C</li> </ul>   |
| <b>5</b>  | Operations engineer, Unit D                          | <ul style="list-style-type: none"> <li>• Retrofit proposals 5, 6</li> </ul>   |
| <b>6</b>  | Process engineer, Unit D                             | <ul style="list-style-type: none"> <li>• Retrofit proposals 5, 6</li> </ul>   |
| <b>7</b>  | Control engineer                                     | <ul style="list-style-type: none"> <li>• Discussion about process control system</li> <li>• Retrofit proposals 1A, 4C, 5</li> </ul>                         |
| <b>8</b>  | Control engineer                                     | <ul style="list-style-type: none"> <li>• Discussion about control of the steam utility system</li> </ul>  |
| <b>9</b>  | Process engineer, energy systems                     | <ul style="list-style-type: none"> <li>• Discussion about the steam utility system and the fuel gas system</li> <li>• Retrofit proposal 4A, 6</li> </ul>    |
| <b>10</b> | Mechanical engineer, heat exchangers and air coolers | <ul style="list-style-type: none"> <li>• Discussion about heat exchangers and air coolers at the refinery</li> <li>• Retrofit proposal 1A, 4A, 5</li> </ul> |
| <b>11</b> | Mechanical engineer, boilers and process heaters     | <ul style="list-style-type: none"> <li>• Discussion about fired heaters and boilers at the refinery</li> <li>• Retrofit proposal 1A, 2, 5</li> </ul>        |

Finally, results from the interviews were summarized and presented at a validation seminar which was attended by several of the interviewed engineers as well as managers responsible for process development. The results and main conclusions from the interviews were presented to the refinery experts involved in the study. The refinery experts confirmed and clarified the results.

Consequently, a comprehensive and systematic in-depth coverage of the included topics was achieved.

# CHAPTER 6

## - RESULTS

---

In this chapter, selected results from the interview study and steam system modelling are summarized and presented. First the interview results are summarized in a table that displays how the issues discussed during the interviews connect to the process implications defined in the theoretical framework (see Section 5.1 for an explanation of process implications). Then, the results from the table are further explained by individually presenting results related to practical considerations, operability issues, steam system model results and NEBs.

A summary of the interview results is presented in Table 6. The table is structured based on the process implications listed in Section 5.1 and provides a summary of the main findings related to each process implication. Each finding from the interviews is also categorized according to whether the main effect was connected to practical issues, operability aspects, the steam system balances and/or NEBs. Most issues discussed during the interviews have possible solutions that were also discussed in the interviews. These solutions are also pointed out in the table. The results summarized in the table are discussed in more detail in this chapter.

Table 6. Selected results that were highlighted in the interviews connected to process implications displayed in Table 2.

| <b>Process implication</b>                               | <b>Concern/opportunity raised by interviewees (Retrofit proposal #)</b>  | <b>Main topic discussed</b>   | <b>Comment</b>  |
|--|--|-------------------------------|---|
| <b><i>De-bottlenecking</i></b>                           | Load reduction in a furnace before a reactor could create increased flexibility to further heat the flow and thereby increase production capacity at the end of the reactor catalyst cycle. (RP 4A-C)                        | NEB Flexibility               |   |
|  | If an existing heat exchanger is replaced with new parallel compact heat exchangers to enable space for new equipment, cleaning of existing heat exchangers would be possible without decreasing the production in the unit. | NEB Reliability/ Availability |   |
| <b><i>Stream splitting</i></b>                           | Stream splitting is not necessarily an issue but requires new valves, new data acquisition and further investigation of control system consequences. (RP 4C)   | Controllability               |   |
| <b><i>HEN complexity</i></b>                             | No major issues brought up during interviews.  | -                             | Further investigation needed to evaluate this implication. Literature discusses that increased interconnections can cause operability issues. |
| <b><i>Reduced load on a furnace</i></b>                  | This was discussed for several of the retrofit proposals but no major issues were identified.  | -                             | The furnaces discussed have the possibility to shut down individual burners if the load is heavily reduced.                                   |
| <b><i>Reduced load on an air cooler</i></b>              | This was discussed for several of the retrofit proposals but no major issues were identified. However, it could be a NEB that the load can be reduced on air coolers with capacity limitations during summer periods.        | NEB Flexibility               |   |
| <b><i>Increased pressure drop in heat exchangers</i></b> | For large increases in area, the pressure drop can cause issues for the process streams to flow to the next process unit.  | Controllability               | If area is increased, pressure drop must be further investigated to evaluate if a new pump is needed.   |
| <b><i>Change in steam balance</i></b>                    | Savings in LP steam do not lead to fuel gas savings since there is an excess of LP steam in the refinery which is vented to the atmosphere.  | Steam system                  | Results discussed in interviews and confirmed by steam system model.  |
|  | Changes in steam system balances are hard to evaluate without a steam system model due to the complicated steam system with interconnections between different steam headers.  | Steam system                  | Steam system model enabled evaluation of uncertainties regarding the steam and fuel balances from the interviews.                             |

|  |  |                          |   |
|--|--|--------------------------|---|
| <b><i>Shut-down of furnace before reactor</i></b>                    | With the furnace in operation, the possibility of emergency shut-down of the furnace provides a way to rapidly lower the temperature of the process stream going into the strongly exothermic reactor to avoid reactor runaway. If the furnace is shut down, this emergency function needs to be replaced by another way of rapidly lowering the reactor inlet temperature. (RP 5) | Controllability          | Put a by-pass on a heat-exchanger prior to the reactor to be able to by-pass the flow and lower the temperature quickly   |
|  | The process furnace cannot be removed because of the need to heat process streams during start-up before all process heat sources becomes available. (RP 5)  | Start-up/<br>Shut-down   | Keep existing furnace to be used during start-up and allow by-pass during normal operation.   |
| <b><i>Heat exchange between process units</i></b>                    | The ability to operate the units independently is lost if heating/cooling in one unit becomes dependent on the other unit being in operation. (RP 1A-C)  | Flexibility              | Keep existing utility heaters and coolers to be used as a back-up if one unit is temporarily shut down, and by-pass them during normal operation of both process units. |
| <b><i>New equipment installation</i></b>                             | There are major spatial limitations in investigated process units. There is also limited amount of time during expensive turnaround periods.   | Practical considerations | One option to enable space is to replace existing equipment with new space efficient equipment.   |
| <b><i>Rebuilding existing equipment</i></b>                          | When rebuilds require more space, there are significant spatial limitations in investigated process units. There is also limited amount of time during expensive turnaround periods.   | Practical considerations | One option to enable space is to replace existing equipment with new space efficient equipment.   |
| <b><i>Pressure differences between streams or high pressures</i></b> | High pressures gives more expensive equipment which decreases the possibilities for implementation.  | Practical considerations |   |

## **6.1 PRACTICAL CONSIDERATIONS**

When discussing the potential to implement the different HEN retrofit proposals during the interviews, practical considerations were repeatedly raised as the major concerns. The most frequently mentioned practical issues were:

- Spatial limitations
- Space and time for rebuilt during expensive turn-arounds
- Expensive equipment due to high operating pressures

Follow-up discussions during the interviews support, however, that most practical implementation issues can be solved, but at the expense of higher investment costs for the implementation of the HEN retrofit proposal. For example, spatial limitations can be resolved by replacing existing equipment with more compact equipment to make room for the installation of new equipment. For energy-efficiency projects to be prioritized during expensive turn-arounds, the inclusion of non-energy benefits could make the proposals more attractive. Additionally, increased pressure drops need to be further investigated to evaluate if a new pump is needed and if so, whether the existing pipes and other equipment can withstand the higher pressure.

## **6.2 OPERABILITY**

This section presents results from the interviews concerning the possible effect of the HEN retrofit proposals on operability. These are selected results that do not cover all topics discussed in the interviews, but the results presented are the most important and repeatedly mentioned aspects of operability.

During the interviews, increased maintenance was mentioned as a potential issue. It was explained that there needs to be both space and time to clean the heat exchangers. If the heat exchangers are not properly cleaned, pressure drops increase significantly, which can cause issues transporting the process flows to downstream units with only slightly lower pressure. Heat exchangers that already experience problems with fouling are likely to be penalized by reduced reliability/availability if enlarged, due to the increased need for maintenance during operation. For tube-and-shell heat exchangers, the reduction in reliability/availability is caused by the need to lower the feed flowrate to the unit to enable cleaning on both the tube and shell sides of the heat exchanger. One solution stated by several interviewees to the reliability/availability issues caused by fouling, is to remove existing shell-and-tube exchangers and replace them with compact parallel plate exchangers. In the interviews, it was stated that a simultaneous investment to improve current operability issues caused by fouling could increase the prospect of investing in an energy saving project. This was seen to be the case for retrofit proposal 1A. Combining an extension of the heat exchanger with a replacement of the existing shell-and-tube heat exchanger would not only decrease energy use, but would also decrease fouling problems. The parallel plate exchangers would fit in the original space and also achieve a higher heat transfer load. Since there would be heat exchangers in parallel, one could be in operation while the other one is

cleaned avoiding disrupting operation of the process unit. This reasoning was confirmed in several of the interviews as well as at the validation seminar.

The effect on flexibility and controllability from increased interconnections and complexity was mentioned as a potential issue during some interviews, but was considered to need further investigation for evaluation of its significance. For retrofit proposal 1B (see Paper II), it is suggested to heat a distillation column reboiler through internal heat exchange with a hot process stream instead of using utility steam. The retrofit proposal involves several new interconnections, both within the process unit (Unit B) and between Unit A and Unit B. It was considered a potential problem that the reboiler would become dependent on other parts of the unit. Whether the increased number of interdependencies would have a significant effect on the reboiler operability needs to be investigated further. Similar issues were discussed regarding retrofit proposal 4C (see Paper II) in which a stream split is included. Stream splits are not used to a great extent in the process units for which the interviewed process and operations engineers are responsible and they therefore had no clear opinion about possible impacts on operability. The control engineer, on the other hand, stated that the stream split is possible but new control valves and measurements are needed, as well as a more thorough analysis of the control system structure. However, at the validation seminar it was acknowledged that almost all refineries have several well-functioning stream splits in the crude oil pre-heating unit. Both examples (the integration of the reboiler in 1B and the stream split in 4C) show that a large increase in interdependencies might cause operability issues, but to know whether this is the case, and how it then can be managed, a more thorough analysis is needed that could include, for example, modelling and simulation and potentially more advanced control structure design.

Safety aspects were discussed in many interviews, especially regarding retrofit proposal 5 (see Paper II). In the proposal, a process furnace was suggested to be taken out of operation since it is not needed from an energy point of view. Increased internal heat exchange could easily replace the heat provided by the furnace. The process furnace is placed prior to an exothermic reactor with a very sensitive inlet temperature. During the interviews it was clear that the retrofit proposal would not create a controllability issue with the stabilizing control of the reactor inlet temperature during normal operation if the furnace is taken out of operation. The temperature control would not be affected since the control is placed prior to the furnace. However, it was very clear during the interviews that a safety issue could occur. In all interviews regarding retrofit proposal 5, it was explained that it is necessary to be able to rapidly lower the reactor inlet temperature if a runaway reaction occurs. This is currently accomplished by shutting down the furnace. If the furnace is to be taken out of operation, another solution would be necessary to stop potential runaway reactions. Possible solutions were discussed during the interviews, but the safety control for the retrofit proposal needs to be thoroughly investigated if the retrofit proposal is to be implemented.

### 6.3 STEAM SYSTEM CONSEQUENCES

Three retrofit proposals were evaluated using the steam system model for three operating scenarios. All retrofit proposals that were used as examples in the steam system model were also included in the interview study. In Table 7, results from the steam system model are displayed for the three operating scenarios mentioned in Section 5.3. In the table, an increase in LP steam consumption corresponds to retrofit proposal 4B (see Paper II) and a decrease in HP steam consumption corresponds to retrofit proposal 6 (see Paper II). In the table, the decrease in LP steam consumption corresponds to the part of retrofit proposal 1B (see paper II) that is connected to steam savings. It should be noted that for retrofit proposal 4B and retrofit proposal 6, the modified steam balances enable fuel savings in process furnaces in the respective process units. Consequently, the total site savings will depend on the effect on the steam system compared with the fuel savings in the process furnaces.

Table 7. Results from steam system evaluation for the three operating scenarios displayed in Table 4. For retrofit proposal 6, A and B indicate different examples of operating responses to the changes for Scenarios 2 and 3.

| Retrofit proposal  | Model input |                              |   | Model output                                       |                              |   |
|--|-------------|------------------------------|---|--|------------------------------|---|
|  | Scenario    | Change in steam balance [MW] | Change in fuel consumption in process furnaces [MW] | Changed fuel gas consumption in steam boilers [MW] | Total site fuel savings [MW] | Change in total site electricity consumption [MW] |
| <b>Part of RP 1B</b><br>(Decrease in LP steam consumption) | 1           | 2.2                          | -   | -  | -                            | -   |
|  | 2           | 2.2                          | -   | -  | -                            | -   |
|  | 3           | 2.2                          | -   | -  | -                            | -   |
| <b>RP 4B</b><br>(Increase in LP steam consumption)         | 1           | -10                          | -12.4   | 0.7  | -11.7                        | -   |
|  | 2           | -10                          | -12.4   | -  | -12.4                        | -   |
|  | 3           | -10                          | -12.4   | 10.6   | -1.8                         | -0.8  |
| <b>RP 6</b> (Decrease in HP steam production)              | 1           | -7.5                         | -8.1  | -  | -8.1                         | -   |
|  | 2A          | -7.5                         | -8.1  | -  | -8.1                         | 0.3   |
|  | 2B          | -7.5                         | -8.1  | -  | -8.1                         | 0.2   |
|  | 3A          | -7.5                         | -8.1  | 9.3  | 1.3                          | -0.2  |
|  | 3B          | -7.5                         | -8.1  | 9.0  | 1.0                          | -   |

The results show that decreased LP steam consumption does not lead to total site energy savings in any of the investigated operating scenarios; it will only lead to increased venting of LP steam. This will be the same independently of how large the steam savings are compared to retrofit proposal 1B, since there is a surplus of LP steam for all modelled scenarios. For other operating scenarios with no LP steam surplus, a saving in LP steam could lead to fuel gas savings in the steam boilers. This, however, only occurs a few times per year, as stated in the interviews with the process engineer responsible for the refinery energy systems.

For retrofit proposal 4B, fuel savings in a local process furnace are enabled by increased preheating of a process stream using LP steam. The increase in LP steam consumption will lead to different results depending on the balance on the LP steam header in each operating scenario. If a lot of LP steam is vented to the atmosphere, the higher LP steam demand can be covered to a large extent by this excess steam and, consequently, the fuel savings for the total site will be larger. This is the case for Scenarios 1 and 2, and for those scenarios the furnace fuel savings will be the same as the total site savings since the load of the steam boilers does not need to be increased. If only a little LP steam is vented to the atmosphere, more steam must be produced in the steam boilers to compensate for the higher steam consumption. This is the case for Scenario 3, where additional VHP steam must be produced in the steam boilers to compensate for the increased LP steam demand. As a result, the increased VHP steam can be let-down through switchable turbines to lower pressure headers and thus therefore decrease the electricity need. However, the increased load on the steam boilers makes the total site fuel savings smaller for Scenario 3 than for Scenarios 1 and 2.

For retrofit proposal 6, in which HP steam production is decreased in favor of decreased fuel gas use in a process furnace, the results vary significantly depending on the balances on the steam headers. In this case, operational decisions also have a major impact, and for the more complex cases Scenario 2 and 3, results for two versions of each scenario are displayed to show the effect of two alternative operational responses. However, more than the two versions of Scenarios 2 and 3 displayed in the table are possible and the results show examples of steam system consequences that depend on operational decisions. For Scenarios 1 and 2, there are steam surpluses larger than the decrease in HP steam production, at the HP header and at lower pressure headers. This means that there is no need to increase the production of VHP in the steam boilers. For Scenario 2, there is not enough steam going through let-down valves to lower pressure levels to compensate for the decrease of HP steam production. However, there are large enough surpluses of steam at MP and LP levels, meaning that turbine-driven equipment can be switched to electrical drive to compensate for the decreased HP steam production. This leads to a higher electricity consumption for the refinery but the total site fuel savings are not affected by the steam system, and all of the savings achieved in the process furnace can be accounted for. For Scenario 3, the steam flow at MP and LP headers is not enough to compensate for the decreased HP consumption. Therefore, the production of VHP must be increased and let-down to lower pressure levels. This also means that more rotating equipment can be switched from electrical drive to turbine-drive and the electricity consumption for the refinery is decreased. However, the increased load of the steam boilers leads to a large increase in fuel consumption in from a total site perspective, and the fuel savings in the process furnace resulting from RP 6 are not enough to save fuel at the total site level.

For more detailed descriptions of the results and steam system configuration, see Paper III.

## 6.4 NON-ENERGY BENEFITS

Although the interview study focused on potential operability issues rather than benefits, NEBs were raised as important in several of the interviews. The retrofit proposals that included NEBs also tended to receive a higher score when the engineers had to grade the implementation potential for the proposals. Examples of NEBs discussed during the interviews are listed below.

- Production increase
- Increased product quality
- Decreased issues with over-loaded air coolers during summer

Two examples for which a potential production increase was pointed out as a NEB were identified in the interview study. The first example included a process furnace that limits the production capacity during certain periods. The furnace is located upstream from reactors that require higher inlet temperature as the catalyst deactivates. At operating points requiring a high inlet temperature to the reactors, the furnace becomes a bottleneck since its capacity is limited by insufficient flue gas channels. Reducing the normal operation load on the furnace would thereby enable maintained production during the entire catalyst cycle and increase the flexibility of the process unit. The other example of potential for increased production as a NEB concerns a heat exchanger with fouling issues. To be able to make space for new equipment and extended area in the existing heat exchanger, the existing heat exchangers would have to be replaced with new space-efficient equipment, which would increase the production capacity for the unit through significantly increased reliability/availability.

One example of when increased product quality could be achieved is when increased flexibility of changing the feed stream temperature to a distillation column can be achieved. When the process furnace in retrofit proposal 6 (see Paper II) is operating at full load, the outlet temperature set point cannot always be met. A furnace load decrease would provide increased flexibility to further raise the column feed inlet temperature if required. Another NEB mentioned was decreased issues with over-loaded air coolers during summer. During summer days, the air coolers do not always have the capacity to condense enough products, creating a large excess of refinery fuel off-gas containing valuable products. If all gas cannot be combusted in process furnaces and steam boilers, the refinery production must be decreased to lower the production of fuel gas. Consequently, decreased load on air coolers could reduce this issue.

# CHAPTER 7

## - DISCUSSION

---

The steam system model enables the inclusion of the complex steam system effects in the analysis of energy efficiency measures in individual process units. However, despite having access to such a model, difficulties remain when analysing operational decisions and operational strategies. Operation of real industrial steam systems is rarely fully optimized and operational decisions are often made manually as responses to changes in steam generation and demands. The heuristics of such experience-based responses makes it difficult to determine a unique and most likely consequence of a change in steam balances resulting from a HEN retrofit measure. The savings also vary over time depending on the varying steam balances from process variations and ambient conditions. Consequently, the results from the steam system model provides an indication of how the steam and fuel balances are affected, but does not give an exact result.

Economic trade-offs are implicitly included in traditional pinch analysis-based design through the choice of minimum temperature difference for heat exchange. Alternative HEN designs are typically also compared based on their economic performance. However, to avoid discussions about economic feasibility dominating the interviews, an economic evaluation of HEN retrofit designs was not included for the retrofit proposals in this work. In traditional pinch design, the profitability of heat integration rebuilds is assumed to depend primarily on the energy cost savings and the investment cost for new heat exchangers and related equipment. Operability considerations are likely to affect both the operating and investment costs for heat integration retrofit measures. Traditional pinch analysis is done for steady-state operation. In order to achieve good dynamic operability, additional equipment might be required, for example, additional investment in equipment for advanced control systems and/or over-capacity or back-up systems for flexible production. Additionally, if flexibility is considered, the heat savings can vary for different operating scenarios which change the expected heat savings, affecting the cash flows and the expected profitability. Non-energy benefits also affect the profitability of the heat integration retrofit proposals by increasing the revenues.

Although only one industrial site was investigated in this study, the results are likely to be applicable to other energy-intensive process plants. Most of the operability issues discussed during the interviews and in the literature review and theoretical framework are not specific for oil refineries. The same applies to all types of industrial plants with complex steam utility systems. In the process industry, the main share of the energy use is closely connected to the core production process. Heating and cooling in local process heaters, coolers and heat exchangers directly affect the process streams going through these units. Total energy use is affected by process-to-process heat exchange as well as by indirect heat recovery through utility systems such as steam networks or hot water circuits. Interconnections between different processes, and

the close integration of the energy system and the production process indicate that operability issues are important to consider in similar ways in other oil refineries as well as other energy-intensive process industries. However, some of the operability issues investigated in this study are specific for the oil refinery case. More case studies are needed to evaluate to what extent the operability issues can be generalized for any type of industrial process plant. The theoretical framework and the approach proposed in this thesis can be used as a good ground for such further studies.

This thesis investigated the impact of process operability considerations for decisions regarding heat integration measures. Although measures to increase the heat integration within an industrial site are clearly measures for energy efficiency, they can also be seen as measures that modify the integrated system of a production process and its energy utility. As previously stated, the close connection between energy use and the core production process is common for all energy-intensive industries. The case study considered in this thesis showed that technical aspects related to the production process are crucial to consider to be able to successfully implement these kinds of energy efficiency measures. Because of their connection to the core production process, as well as their dependency on other measures and modifications to the integrated energy and process system, there are strong reasons to not equate heat integration measures with stand-alone EEMs in support processes when evaluating, for example, barriers, non-energy benefits and energy savings potentials. Heat integration measures need to be designed for each industrial site considering the specific characteristics of the infrastructure and the processes integrated in that system. It must be acknowledged that heat integration implies a risk that the core production can be negatively affected, in which case the economic consequences are potentially huge since the plant revenues rely on small margins on large-volume, high-availability production. To summarize, the nature of heat integration measures provides strong reasons for not neglecting operability and other technical aspects when evaluating the potential for their implementation.

De-bottlenecking as a NEB of increased process integration has been discussed in the literature before. Lundberg et al. [77] identified the positive effects of de-bottlenecking the recovery boiler at a Kraft pulp mill if heat integration measures are implemented simultaneously when rebuilding the plant. Dhole and Buckingham [78] proposed a methodology to simultaneously consider pinch analysis and column targeting (modification of column design to fit thermodynamic profiles obtained from pinch analysis) for a refinery, to obtain de-bottlenecking without increasing the existing furnace load. See also Li et al. [79] for a description of combining de-bottlenecking and pinch analysis in oil refining industry. These examples indicate that the importance of the non-energy benefit de-bottlenecking shown in the interview study is applicable for other cases than the selected oil refinery.

# CHAPTER 8

## - CONCLUSIONS

---

This thesis showed the importance of considering operability for increased heat integration through Heat Exchanger Network (HEN) retrofits and discussed various aspects of operability and other practical implementation issues. Increased integration in the process can cause issues both concerning possibilities to rebuild the process as well as operate the process. However, according to the interview study, the majority of the concerns raised about operability and practical implementation issues can be resolved technically, but possibly involving additional costs. For example, to ensure controllability and flexibility of the design further investigations and back-up solutions might be needed, and to ensure reliability/availability and to solve practical implementation issues such as spatial limitations additional investments and rebuilding of existing equipment might be necessary.

The results from the interview study also highlighted the importance of considering Non-Energy Benefits (NEBs) of Energy Efficiency Measures (EEMs) such as heat integration measures, which involve system modifications, and are closely integrated with the core production process. Several NEBs were identified and their importance were pointed out in several interviews as well as at the final seminar that was set up to validate the results of the interview study. The most important NEB identified was increased production, which would probably give large economic incentives to implement heat integration measures.

The steam system model was crucial to be able to evaluate the fuel savings for HEN retrofit proposals that impact the steam system. The steam system model presented in this thesis is able to capture the complex effects of modifying steam system operation. For example, a saving in Low Pressure (LP) steam for the case study does not result in any savings in fuel gas due to the excess of LP steam in the refinery at most operating points. On the other hand, when LP steam is used or High Pressure (HP) steam production is reduced in favour of reduced load in a process furnace, the possible total site fuel savings vary between different operating points as well as the effect on electricity balances. The results also showed how changing a high-quality hot utility such as heating in a process furnace to a lower-quality hot utility such as low-pressure steam can lead to large fuel savings even though the same amount of hot utility is used.

The complexity of steam system effects, alongside with the more interconnected processes resulting from increased process-to-process heat exchange, clearly showed the need to consider system effects from this type of EEM. Other EEMs could be close to the core process without having system effects (e.g. exchanging an old pump for a more efficient pump to decrease electricity consumption). The system effects add another dimension of complexity to the EEMs which require additional analysis to evaluate the consequences from the EEMs. Additionally, the

measures cannot be viewed separately since they can affect each other as well as the total savings potential.

To summarize the results from the thesis, it can be concluded that it is valuable to take process aspects into consideration at an earlier design stage when constructing HEN retrofits for increased heat integration. If operability, NEBs, practical implementation issues and utility systems are considered already in the techno-economic analysis and not postponed until the more detailed pre-feasibility or feasibility study phase, several issues can be avoided and large benefits could be achieved for the process. The inclusion of those factors would also lead to a better estimation of techno-economic potentials for heat integration measures and thereby a more accurate screening process for different climate mitigation options. If the early design focuses on for example bottlenecks in the process, a simultaneous energy saving and production increase could be achieved, leading to more competitive heat integration measures with large productivity, economic and environmental benefits.

# CHAPTER 9

## - FUTURE WORK

---

This thesis concluded that important process aspects such as operability, NEBs, practical implementation issues and utility systems, should be considered at an earlier stage in the design process for energy efficiency measures. Better knowledge about the effects of such process aspects could improve the screening of options for energy efficiency improvements, including their potential for climate mitigation. Therefore, it would be interesting to further investigate how large the effects are to know which are the most important to consider. It would also be beneficial to confirm the results with more case studies, both in oil refining industry and in other energy-intensive process industries. More case studies would also be needed to confirm how general the results from this thesis are and to know what process aspects to consider in other energy-intensive industries.

The results showed that NEBs are likely to have a decisive effect on the possibilities to implement heat integration measures. To further show the importance of NEBs it would be valuable to quantify the possible economic effects of NEBs. This would be valuable both to prove their importance but also to differentiate between different kinds of NEBs and to know which NEBs are most important. Quantifying NEBs would allow for a more fair comparison between projects, where all benefits are included in the economic evaluation. It could also give guidance about which NEBs to target in HEN retrofit and grassroots design. Furthermore, it would be interesting to see how the value of the NEB of reduced fossil carbon dioxide emissions can change, i.e. how large the effects could be in future scenarios compared to the value today.

In contrast to NEBs, operability issues are important to quantify to be able to know which are most important to avoid. Since many of the possible operability issues require more investigation and/or back-up solutions, it is crucial to know the additional cost associated with these requirements. It is also necessary to know which operability issues would imply significant additional costs, and which operability issues would have negligible cost penalty.

Results from this thesis, from economical quantifications of important process implications and benefits, and from more case studies could possibly be used as a ground for suggesting a better methodology for HEN design, both in retrofit and grassroots situations. Additionally, if the economic effect of NEBs and operability issues are better known, better techno-economic assessments could be conducted, improving the possibilities to choose the best pathway for new processes and for improving existing processes' energy efficiency. Therefore, it would be interesting to further investigate the effects of such process aspects and how they can be implemented in the screening process. One example of how to display the effects could be to include the process aspects in the construction of marginal abatement cost curves (MACC) or

energy conservation supply curves. Future work could investigate how operability issues, NEBs, practical implementation issues and system effects could affect the ranking of carbon abatement options in MACCs (or energy conservation measures in the conservation supply curves), and analyse how those process aspects influence the carbon emission reduction and energy efficiency potentials.

## REFERENCES

---

1. IEA, *World Energy Outlook*. 2017: IEA Publications.
2. Naturvårdsverket. *Utsläpp i siffror*. 2018; Available from: <https://utslappisiffror.naturvardsverket.se>. [September 6<sup>th</sup> 2018]
3. UNFCCC, United Nations. *Adoption of the Paris agreement*. 2015; Available from: <https://unfccc.int/resource/docs/2015/cop21/eng/109r01.pdf> [August 24<sup>th</sup> 2018]
4. European Commission. *2030 Climate & Energy Framework*. ; Available from: [https://ec.europa.eu/clima/policies/strategies/2030\\_en](https://ec.europa.eu/clima/policies/strategies/2030_en) [August 24<sup>th</sup> 2018]
5. European Commission. *Energy Efficiency*. 2018; Available from: <https://ec.europa.eu/energy/en/topics/energy-efficiency> [September 25<sup>th</sup> 2018]
6. Naturvårdsverket. *Utsläpp av växthusgaser från industrin*. 2017; Available from: <http://www.naturvardsverket.se/Sa-mar-miljon/Statistik-A-O/Vaxthusgaser-utslapp-fran-industrin/> [October 15<sup>th</sup> 2018]
7. Naturvårdsverket. *Energieffektivisering i industrin*. 2018; Available from: <https://www.naturvardsverket.se/Miljoarbete-i-samhallet/Miljoarbete-i-Sverige/Uppdelat-efter-omrade/Energi/Energieffektivisering/Industrin/> [October 17<sup>th</sup> 2018]
8. Naturvårdsverket. *Etappmålen*. 2018; Available from: <http://www.naturvardsverket.se/Miljoarbete-i-samhallet/Sveriges-miljomal/Etappmal/> [October 17<sup>th</sup> 2018]
9. Jaffe, A.B. and R.N. Stavins, *The energy efficiency gap - What does it mean?* Energy Policy, 1994. **22**(10): p. 804-810.
10. Johansson, M.T. and P. Thollander, *A review of barriers to and driving forces for improved energy efficiency in Swedish industry-Recommendations for successful in-house energy management*. Renewable & Sustainable Energy Reviews, 2018. **82**: p. 618-628.
11. Solnordal, M.T. and L. Foss, *Closing the Energy Efficiency Gap-A Systematic Review of Empirical Articles on Drivers to Energy Efficiency in Manufacturing Firms*. Energies, 2018. **11**(3).
12. Fleiter, T., S. Hirzel, and E. Worrell, *The characteristics of energy-efficiency measures - a neglected dimension*. Energy Policy, 2012. **51**: p. 502-513.
13. Thollander, P. and M. Ottosson, *An energy efficient Swedish pulp and paper industry - exploring barriers to and driving forces for cost-effective energy efficiency investments*. Energy Efficiency, 2008. **1**(1): p. 21-34.
14. Rohdin, P., P. Thollander, and P. Solding, *Barriers to and drivers for energy efficiency in the Swedish foundry industry*. Energy Policy, 2007. **35**(1): p. 672-677.
15. Dieperink, C., L. Brand, and W. Vermeulen, *Diffusion of energy-saving innovations in industry and the built environment: Dutch studies as inputs for a more integrated analytical framework*. Energy Policy, 2004. **32**(6): p. 773-784.
16. Anderson, S.T. and R.G. Newell, *Information programs for technology adoption: the case of energy-efficiency audits*. Resource and Energy Economics, 2004. **26**(1): p. 27-50.
17. Cagno, E. and A. Trianni, *Evaluating the barriers to specific industrial energy efficiency measures: an exploratory study in small and medium-sized enterprises*. Journal of Cleaner Production, 2014. **82**: p. 70-83.
18. IEA, *Capturing the Multiple Benefits of Energy Efficiency*. 2014: [IEA], International Energy Agency.

19. Pye, M. and A. McKane, *Making a stronger case for industrial energy efficiency by quantifying non-energy benefits*. Resources Conservation and Recycling, 2000. **28**(3-4): p. 171-183.
20. Trianni, A., E. Cagno, and S. Farne, *Barriers, drivers and decision-making process for industrial energy efficiency: A broad study among manufacturing small and medium-sized enterprises*. Applied Energy, 2016. **162**: p. 1537-1551.
21. Rasmussen, J., *The additional benefits of energy efficiency investments-a systematic literature review and a framework for categorisation*. Energy Efficiency, 2017. **10**(6): p. 1401-1418.
22. Brunke, J.C., M. Johansson, and P. Thollander, *Empirical investigation of barriers and drivers to the adoption of energy conservation measures, energy management practices and energy services in the Swedish iron and steel industry*. Journal of Cleaner Production, 2014. **84**: p. 509-525.
23. Arens, M., E. Worrell, and W. Eichhammer, *Drivers and barriers to the diffusion of energy-efficient technologies-a plant-level analysis of the German steel industry*. Energy Efficiency, 2017. **10**(2): p. 441-457.
24. Méchaussie, E.M., *Methodology for efficient use of thermal energy in the chemical and petrochemical industry*. 2018, École Polytechnique Fédérale de Lausanne: Lausanne, EPFL.
25. Subramanian, S. and C. Georgakis, *Methodology for the steady-state operability analysis of plantwide systems*. Industrial & Engineering Chemistry Research, 2005. **44**(20): p. 7770-7786.
26. Setiawan, R. and J. Bao, *Operability analysis of chemical process network based on dissipativity*, in *Ascc: 2009 7th Asian Control Conference, Vols 1-3*. 2009, IEEE: Hong Kong, China. p. 847-852.
27. Setiawan, R. and J. Bao, *Analysis of Interaction Effects on Plantwide Operability*. Industrial & Engineering Chemistry Research, 2011. **50**(14): p. 8585-8602.
28. Kemp, I.C., *Pinch analysis and process integration: a user guide on process integration for the efficient use of energy*. 2nd ed. 2007: Elsevir Ltd.
29. Klemeš, J., *Sustainability in the process industry: integration and optimization*. 2011, New York: McGraw-Hill Professional.
30. Sreepathi, B.K. and G.P. Rangaiah, *Review of heat exchanger network retrofitting methodologies and their applications*. Industrial & Engineering Chemistry Research, 2014. **53**(28): p. 11205-11220.
31. Butun, H., I. Kantor, and F. Marechal, *A heat integration method with multiple heat exchange interfaces*. Energy, 2018. **152**: p. 476-488.
32. Zhang, D., G.L. Liu, and Y.F. Li, *Graphical optimization method for coupled heat exchanger network and reactor*. Energy, 2018. **156**: p. 635-646.
33. Pan, M., I. Bulatov, and R. Smith, *Heat transfer intensification for retrofitting heat exchanger networks with considering exchanger detailed performances*. Aiche Journal, 2018. **64**(6): p. 2052-2077.
34. Klemeš, J.J., et al., *New directions in the implementation of Pinch Methodology (PM)*. Renewable and Sustainable Energy Reviews, 2018. **98**: p. 439-468.
35. Becker, H. and F. Maréchal, *Energy integration of industrial sites with heat exchange restrictions*. Computers & Chemical Engineering, 2012. **37**: p. 104-118.

36. Ulyev, L., M. Vasiliev, and S. Boldyryev, *Process integration of crude oil distillation with technological and economic restrictions*. Journal of Environmental Management, 2018. **222**: p. 454-464.
37. Hiete, M., J. Ludwig, and F. Schultmann, *Intercompany Energy Integration Adaptation of Thermal Pinch Analysis and Allocation of Savings*. Journal of Industrial Ecology, 2012. **16**(5): p. 689-698.
38. Polley, G.T. and J.D. Kumana, *Practical process integration retrofit: Part 4. Dealing with large projects*, in *2012 AIChE Spring Meeting and 8th Global Congress on Process Safety*. 2012: Houston, TX, United States.
39. Cerda, J. and A.W. Westerburg, *Synthesizing heat-exchanger networks having restricted stream stream matches using transportation problem formulations*. Chemical Engineering Science, 1983. **38**(10): p. 1723-1740.
40. Escobar, M., J.O. Trierweiler, and I.E. Grossmann, *Simultaneous synthesis of heat exchanger networks with operability considerations: Flexibility and controllability*. Computers & Chemical Engineering, 2013. **55**: p. 158-180.
41. Hackl, R. and S. Harvey, *From heat integration targets toward implementation - A TSA (total site analysis)-based design approach for heat recovery systems in industrial clusters*. Energy, 2015. **90**: p. 163-172.
42. Nemet, A., J.J. Klemeš, and Z. Kravanja, *Designing a Total Site for an entire lifetime under fluctuating utility prices*. Computers & Chemical Engineering, 2015. **72**: p. 159-182.
43. Maréchal, F. and B. Kalitventzeff, *Targeting the integration of multi-period utility systems for site scale process integration*. Applied Thermal Engineering, 2003. **23**(14): p. 1763-1784.
44. Verheyen, W. and N. Zhang, *Design of flexible heat exchanger network for multi-period operation*. Chemical Engineering Science, 2006. **61**(23): p. 7730-7753.
45. Čuček, L., et al., *Multi-period synthesis of optimally integrated biomass and bioenergy supply network*. Computers & Chemical Engineering, 2014. **66**: p. 57-70.
46. Abu Bakar, S.H., et al., *Selection of minimum temperature difference (Delta T-min) for heat exchanger network synthesis based on trade-off plot*. Applied Energy, 2016. **162**: p. 1259-1271.
47. Sun, L., S. Doyle, and R. Smith, *Understanding steam costs for energy conservation projects*. Applied Energy, 2016. **161**: p. 647-655.
48. Currie, J., D.I. Wilson, and Ieee, *Rigorously Modelling Steam Utility Systems for Mixed Integer Optimization*. 2012 Conference on Power & Energy - Ipec, 2012: p. 526-531.
49. Aguilar, O., et al., *Optimising the design and operation of industrial utility plants subject to variable demands and prices*, in *European Symposium on Computer-Aided Process Engineering-15, 20A and 20B*, L. Puigjaner and A. Espuna, Editors. 2005. p. 907-912.
50. Velasco-Garcia, P., et al., *Utility systems operation: Optimisation-based decision making*. Applied Thermal Engineering, 2011. **31**(16): p. 3196-3205.
51. Svensson, E., *Flexibility to seasonal demand variations in pulp mill steam production: The effect of steam savings leading to off-design heat loads*. Applied Thermal Engineering, 2014. **70**(2): p. 1180-1188.
52. Kim, S.H., et al., *Economic and environmental optimization of a multi-site utility network for an industrial complex*. Journal of Environmental Management, 2010. **91**(3): p. 690-705.

53. Aguilar, O., et al., *Availability and reliability considerations in the design and optimisation of flexible utility systems*. Chemical Engineering Science, 2008. **63**(14): p. 3569-3584.
54. Varbanov, P.S., S. Doyle, and R. Smith, *Modelling and optimization of utility systems*. Chemical Engineering Research & Design, 2004. **82**(A5): p. 561-578.
55. Micheletto, S.R., M.C.A. Carvalho, and J.M. Pinto, *Operational optimization of the utility system of an oil refinery*. Computers & Chemical Engineering, 2008. **32**(1-2): p. 170-185.
56. Ruiz, D. and C.A. Ruiz, *Industrial Experience in the Deployment of Real Time Online Energy Management Systems*, in *10th International Symposium on Process Systems Engineering*, R.M. deBritoAlves, C.A.O. doNascimento, and E.C. Biscaia, Editors. 2009. p. 1455-1460.
57. Annakou, O., et al., *Operability investigation of energy integrated distillation schemes*. Hungarian Journal of Industrial Chemistry, 1996. **24**(2): p. 155-160.
58. Lima, F.V., et al., *Similarities and Differences Between the Concepts of Operability and Flexibility: The Steady-State Case*. Aiche Journal, 2010. **56**(3): p. 702-716.
59. Aguilera, N.E. and G. Nasini, *Flexibility test for heat exchanger networks with non-overlapping inlet temperature variations*. Computers & Chemical Engineering, 1996. **20**(10): p. 1227-1239.
60. Cerda, J., et al., *Synthesis of flexible heat-exchanger networks .I. convex networks*. Computers & Chemical Engineering, 1990. **14**(2): p. 197-211.
61. Grossmann, I.E., K.P. Halemane, and R.E. Swaney, *Optimization strategies for flexible chemical processes*. Computers & Chemical Engineering, 1983. **7**(4): p. 439-462.
62. Larsson, T. and S. Skogestad, *Plantwide control - A review and a new design procedure*. Modeling Identification and Control, 2000. **21**(4): p. 209-240.
63. Svensson, E., K. Eriksson, and T. Wik, *Reasons to apply operability analysis in the design of integrated biorefineries*. Biofuels Bioproducts & Biorefining-Biofpr, 2015. **9**(2): p. 147-157.
64. Marlin, T.E., *Teaching "operability" in undergraduate chemical engineering design education*. Computers & Chemical Engineering, 2010. **34**(9): p. 1421-1431.
65. Chew, K.H., et al., *Industrial implementation issues of Total Site Heat Integration*. Applied Thermal Engineering, 2013. **61**(1): p. 17-25.
66. *Environmental Application Preemraff Lysekil Appendix A*. 2017-04-06].
67. Andersson, E., et al., *Pinch analysis at Preem LYR*. 2013, Chalmers University of Technology, Gothenburg.
68. Åsblad, A., et al., *Pinch analysis at Preem LYR II - Modifications*. 2014, Chalmers University of Technology, Gothenburg.
69. Sovacool, B.K., *Energy studies need social science*. Nature, 2014. **511**(7511): p. 529-530.
70. Sovacool, B.K., *What are we doing here? Analyzing fifteen years of energy scholarship and proposing a social science research agenda*. Energy Research & Social Science, 2014. **1**: p. 1-29.
71. AspenTech, *Aspen One Engineering Suite v 8.8 Software*. 2015.
72. Subiaco, R., *Modelling, Simulation and Optimization Perspectives of an Industrial Steam Network – Case Study at a Major Oil Refinery on the West Coast of Sweden*. 2016, Chalmers University of Technology: Gothenburg, Sweden.
73. Kobjaroenkun, S. and J. Gunnarsson, *Development of a decision support tool for operational optimization of the steam utility system at Preemraff Lysekil*. 2018, Chalmers University of Technology: Gothenburg, Sweden.

74. Gillham, B., *Research interviewing: the range of techniques*. 2005, New York;Maidenhead;: Open University Press.
75. Kvale, S., *Doing interviews*. Vol. 1. 2007, Thousand Oaks, Calif: Sage Publications.
76. Blandford, A., D. Furniss, and S. Makri, *Qualitative HCI research: going behind the scenes*. 2016, San Rafael, [California]: Morgan & Claypool Publishers.
77. Lundberg, V., et al., *Converting a kraft pulp mill into a multi-product biorefinery - Part I: Energy aspects*. *Nordic Pulp & Paper Research Journal*, 2013. **28**(4): p. 480-488.
78. Dhole, V.R. and P.R. Buckingham, *Refinery column integration for de-bottlenecking and energy-saving*, in *Fourth European Symposium on Computer Aided Process Engineering - Escape 4*. 1994. p. 309-316.
79. Li, S.Y., et al., *Improving Energy Efficiency for Refinery through Bottleneck Elimination*, in *Chemical Engineering Transactions*, P.S. Varbanov, et al., Editors. 2015. p. 1159-1164.



## **LIST OF ABBREVIATIONS**

---

EEM – Energy Efficiency Measure

HEN – Heat Exchanger Network

HP – High Pressure

LP Steam – Low Pressure Steam

LNG - Liquefied Natural Gas

MACC - Marginal Abatement Cost Curves

MP – Medium Pressure

MILP – Mixed Integer Linear Programming

NEB – Non-Energy Benefit

SME – Small and Medium Enterprises

TEA – Techno-Economic Analysis

VHP – Very High Pressure



## ACKNOWLEDGEMENTS

---

First of all, I would like to thank my supervisors Elin Svensson and Simon Harvey. Elin for all discussions throughout the project, for always being helpful and being engaged in my research. You bring me new insights in a pedagogical way and you have taught me so much. Simon for all good discussions, seeing new angles, improving texts and keeping the project in a good direction.

I would also like to thank Eva Andersson and Anders Åsblad for all their help, especially in the beginning of my research. I would not have been able to sort out all stream data without your help and knowledge and thank you for all the work you previously put into extracting and analysing the stream data.

Thank you to the master thesis students I have supervised. Riccardo Subiaco for the enormous amount of work and effort you put into constructing the steam system model, including all your nightly meetings with Aspen tech support. Also, thank you Linnéa Svensson and Tove Udd for your work on non-energy benefits. Your comprehensive and well-done work is something I am hoping to further develop in the continuation of my PhD.

Preem is acknowledged for financing my work and for all valuable input to my research. A special thank you to Per-Olof Eriksson for organising the interviews and for providing important information about the refinery processes. Also a big thank you to all interviewees for being so engaged in the discussions and putting time and effort into the interviews and my research. Thank you to Jörgen Bengtsson for a good collaboration and valuable discussions.

Thank you to my colleagues for making time at work more fun, both at VoM where I started and at Energy Technology where I sit now. A special thank you to my former and present roommates Maria, Johan and Gulnara. You make it more fun to go to work and I have laughed at least once a day since I started my PhD thanks to you.

Thank you to all my friends outside of work for giving me perspective. Ida and Cornelia for always being there and always listening. Emma, Hanna, Amy and Elin for always making me feel good. My cousins for always letting me be myself. Bea, Panos, Cornelia, Elin, Malin and Anna for helping me starting up something great, fighting for what we think is important. Isabelle, Isabelle, Jessica, Mikki and Frida for all playdates and talks, always being supportive towards each other.

I would also like to thank my parents, brothers and grandparents. You have always believed in me and never doubted that I am able to achieve what I want in life. Thank you for your never-ending support and love.

Finally, I would like to thank my husband and daughter(s). Linus, thank you for always keeping me on solid ground, supporting me and for never complaining when I have to work. You are the kindest person I know and you always make me happy, I love you. Elsa, my sunshine, you are

perfect just the way you are and you show me true happiness and endless love. And to baby to come, thank you for keeping me company, can't wait to meet you!

## APPENDIX

---

The appendix provides a short description of the interview procedure with an introductory group meeting and the individual interviews with open and specific question regarding the retrofit proposals. This template was used for interviews with process and operations engineers. For mechanical and control engineers, the template was adjusted for their respective expertise. In the template presented, retrofit proposal 1A is used as an example for the specific questions. The interviews were conducted in Swedish and the questions were translated to English for the purpose of this thesis. Both the translated template and the original Swedish template can be found below.

### **INTERVIEW TEMPLATE TRANSLATED TO ENGLISH**

This section provides a short description of the interview procedure and questions, translated to English.

#### **Introductory group meeting (approx. 30-45 min)**

An introductory group meeting was held with the interview participants before the individual interviews to provide information relevant to all interview participants. The following setup was used for the group meeting:

- Short presentation of the interviewer (Sofie Marton), her PhD project and the purpose of the interviews.
- Participant presentation
- Presentation of retrofit proposals with possibilities for the participants to ask questions to ensure that they fully understand the proposed changes.

The following were highlighted in the preparation for the group meeting presentation:

- Suggested changes in the retrofit proposals should be shown one step at a time, especially important for more complicated retrofit proposals.
- All retrofit proposals should be related to the refinery's own process schemes and graphical illustrations should be very similar to material that the participants are used to.

#### **Individual interviews (approx. 1-2h)**

Here the individual interviews are described as a whole. For specific questions, retrofit proposal 1A is used as an example. The questions were adjusted for each retrofit proposals discussed in each interview. The questions were not designed to be exact and follow-up questions were used to get the information required to understand the interviewees' answers and develop discussions concerning anything unclear. The following was the standard set-up for the interviews:

## ***Introduction***

The purpose is to present the interviewer and discuss the interviewee's professional role and educational background.

- Interviewer presents herself, her role and the purpose of the study. Interviewer explains the setup for the interview with questions and that the interview is recorded.
- **Question 1:** Professional role
  - A, What is your job title? Which are your responsibilities?
  - B, Have you had other responsibilities at the refinery prior to your current position?
  - What experiences do you have from earlier work and education?

## ***Open questions regarding Retrofit proposal 1 A (repeated for other retrofit proposals)***

The purpose is that the interviewee should evaluate the retrofit proposal without being influenced by the interviewer's view about issues/possibilities with the retrofit proposal. The questions are therefore open. Follow-up question should be used when needed to clarify the interviewee's answers.

- The retrofit proposal is presented again and the interviewee is asked if the concept is clear.
- **Question 2:** General evaluation of retrofit proposal
  - A, What possibilities and difficulties do you see with the retrofit proposal?
  - B, Which are the possible consequences for the process if the retrofit proposal is implemented?
- **Question 3:** Implementation of retrofit proposal
  - Would you have to change anything in the process unit to implement the retrofit proposal?
- **Question 4:** Grading of retrofit proposal
  - A, If you would grade the possibility of implementing the retrofit proposal from 1 (not likely to be implemented) to 4 (very likely to be implemented), how would you grade it?
  - B, If you try to keep investment costs and fuel savings out of the grading and only look at the technical aspect, how would you grade the retrofit proposal?
- **Question 5:** Grading of barriers for implementation
  - A, Which are the largest barriers to overcome to implement the retrofit proposal?
  - B, Can you think of any solutions to these barriers?

### ***Specific questions regarding Retrofit proposal 1A (adjusted for other retrofit proposals)***

The purpose of these questions is to ask about possible issues included in the design phase. It is important that these are asked after the open questions. Follow-up question should be used when needed to clarify the interviewee's answers.

- **Question 6:** Furnace load
  - A, How much can the load be reduced on the process furnace?
  - B, Could the process stream be heated in another nearby process furnace if the load is reduced too much?
- **Question 7:** New heat exchanger
  - A, Is it possible to expand the current heat exchanger to double size?
  - B, Can it cause operational issues that the new heat exchanger consists of streams from two different process units?

### ***Comparison (When open and specific questions are asked for all retrofit proposals)***

The purpose is to see how the interviewee rates retrofit proposals and variations of similar retrofit proposals compared to each other.

- **Question 8:** Can you rate the retrofit proposals compared to each other? Which is most likely to be implemented and which is least likely to be implemented?

### ***Final remarks***

The interviewee is thanked for their time and asked if they want to add anything. They are also asked if it is okay to ask supplementary questions later if other questions arise.

## **INTERVIEW TEMPLATE - SWEDISH ORIGINAL**

This section provides a short description of the interview procedure with the original questions in Swedish that were asked during the interviews.

### **Inledande gruppmöte (ca 30-45 min)**

Ett inledande möte hölls med intervjupersonerna innan de individuella intervjuerna. Syftet var att presentera information som var relevant för alla deltagarna i grupp. Följande upplägg användes för gruppmötet.

- Kort presentation av intervjuaren (Sofie Marton), hennes doktorandprojekt och syftet med intervjuerna.
- Deltagarpresentation
- Presentation av åtgärdsförslag med möjlighet för deltagarna att ställa frågor för att garantera att de förstått åtgärdsförslagen.

Följande punkter togs extra hänsyn till under förberedelserna med presentationen till gruppmötet:

- Föreslagna ändringar visas stegvis, extra viktigt för de mer komplicerade förslagen.
- Alla åtgärdsförslag visas i relation till raffinaderiets egna processbilder och materialet ska presenteras på ett liknande sätt som processbilder deltagarna är vana vid.

### **Enskilda intervjuer (ca 1-2h)**

Här beskrivs de enskilda intervjuerna i sin helhet. Detta är ett exempel anpassat för Åtgärdsförslag 1A. Alla intervjuer anpassades sedan efter vilka åtgärdsförslag som diskuterades. Frågorna ska heller inte ses som exakta och följdfrågor användes för att få ut den efterfrågade informationer och fullt förstå intervjupersonens svar samt för att utveckla diskussioner kring oklarheter. Följande upplägg användes under intervjuerna:

#### ***Introduktion***

Syftet var att presentera intervjuaren igen och diskutera intervjupersonens yrkesroll och utbildningsbakgrund.

- Intervjuaren presenterar kort sig själv, sin roll och syftet med projektet igen. Intervjuaren förklarar upplägget med frågor och förklarar hur intervjun spelas in.
- **Fråga 1:** Arbetsroll
  - A, Vilken är din arbetsroll? Vilket ansvarsområde har du?
  - B, Har du tidigare haft andra ansvarsområden på raffinaderiet?
  - C, Vad har du för bakgrund (vad gjorde du innan du arbetade på raffinaderiet)?

#### ***Allmänna frågor om Åtgärdsförslag 1 (Upprepas för andra åtgärdsförslag)***

Syftet är att intervjupersonen ska kunna utvärdera förslaget helt utan påverkan av intervjuarens bild av problem/möjligheter. Det är därför viktigt att frågorna är öppet ställda. För att utreda och utveckla intervjupersonens svar kommer följdfrågor att ställas när det behövs.

- Åtgärdsförslaget presenteras igen för att säkerställa att intervjupersonen fullt har förstått förslaget och intervjupersonen får även möjlighet att ställa frågor.
- **Fråga 2:** Utvärdering av åtgärdsförslag
  - A, Vad ser du för möjligheter och problem med det här åtgärdsförslaget?
  - B, Vilka är konsekvenserna för processen om förslaget genomförs?
- **Fråga 3:** Genomförande av förslag
  - Hade något i anläggningen behövt ändras för att genomföra ombyggnaden?
- **Fråga 4:** Utvärdering av förslag
  - A, Om du skulle gradera möjligheten att genomföra förslaget på en skala från 1 till 4, hur skulle du värdera det då? Om 4 är stora möjligheter och 1 är osannolikt.
  - B, Om du försöker bortse från ekonomiska aspekter kopplat till investeringskostnader och bränslebesparingar och fokuserar på de tekniska förutsättningarna, hur skulle du då gradera möjligheterna att genomföra förslaget på en skala från 1-4?

- **Fråga 5:** Värdering av olika svårigheter
  - A, Vilka skulle du säga är de potentiellt största hindren att överkomma för att kunna genomföra den här åtgärden?
  - B, Har du ett förslag/tanke om hur detta skulle kunna lösas? Går det att göra på något annat sätt?

#### *Specifika frågor om Åtgärdsförslag 1 (anpassas efter varje åtgärdsförslag)*

Syftet är att fråga om potentiella problem som avsiktligt tagits med i åtgärdsförslagen redan i designfasen. Det är viktigt att de specifika frågorna kommer efter de öppna frågorna för att inte påverka intervjupersonens utvärdering av åtgärdsförslagen.

- **Fråga 6:** Ugnslasten
  - A, Hur mycket går det att minska lasten på ungen?
  - B, Skulle det gå att värma flödet i en annan ugn om lasten minskas för mycket?
- **Fråga 7:** Nya värmeväxlare
  - Finns det plats i anläggningen att utöka den befintliga värmeväxlaren? (dubblera)
  - Kan det skapa driftproblem med värmeväxling mellan procesströmmar från två olika anläggningar i den föreslagna nya värmeväxlaren?

#### *Jämförande frågor (Ställs när öppna och specifika frågor ställts för alla åtgärdsförslag)*

Har som syfte att jämföra potential för olika åtgärdsförslag eller varianter/problem av samma förslag.

- **Fråga 8:** Kan du gradera åtgärdsförslagen mot varandra? Vilket tror du är mest sannolikt att implementeras och vilket tror du är minst sannolikt att implementeras?

#### *Avslutning*

Intervjupersonen tackas för att de tagit sig tid och tillfrågas om de har något att tillägga. Det frågas också om det är okej att ställa kompletterande frågor senare om det behövs.