



**CHALMERS**  
UNIVERSITY OF TECHNOLOGY

## **Systematic assessment of triticale-based biorefinery strategies: investment decisions for sustainable biorefinery business models**

Downloaded from: <https://research.chalmers.se>, 2026-04-03 01:38 UTC

Citation for the original published paper (version of record):

Chambost, V., Janssen, M., Stuart, P. (2018). Systematic assessment of triticale-based biorefinery strategies: investment decisions for sustainable biorefinery business models. *Biofuels, Bioproducts and Biorefining*, 12(S1): S9-S20. <http://dx.doi.org/10.1002/bbb.1850>

N.B. When citing this work, cite the original published paper.

# Systematic assessment of triticale-based biorefinery strategies: investment decisions for sustainable biorefinery business models

Virginie Chambost, Polytechnique-Montréal, Montréal, Canada

Matty Janssen, Chalmers University of Technology, Göteborg, Sweden

Paul R Stuart, Polytechnique-Montréal, Montréal, Canada

Received June 5, 2017; revised November 14, 2017; accepted November 15, 2017

View online at Wiley Online Library ([wileyonlinelibrary.com](http://wileyonlinelibrary.com));

DOI: 10.1002/bbb.1850; *Biofuels, Bioprod. Bioref.* 12 (Suppl. 1):S9–S20 (2018)

**Abstract:** Strategic investments in biorefinery projects are increasingly being made, and involve non-traditional decision making, especially considering the technology and market risks involved. From the investor's perspective, the decision-making process leading to product/process combinations for implementation as a biorefinery to achieve a sustainable business model and good economic returns is not obvious. Typical metrics used for investment decision making have some limitations regarding the recognition of acceptable technology risks relative to economic returns. They often do not appropriately consider factors and analyses related to, for example, environmental impact and the longer term competitive position of new product portfolios. The methodology presented in this article is an approach to identifying a 'practical' set of multi-disciplinary decision-making criteria to enable the selection of the preferred product/process biorefinery implementation strategy. The case of investment options in the triticale (*X Triticosecale Wittmack*) biorefinery is used as an example. Through this risk-based methodology, technology risks as well as economic, environmental, and competitive benefits associated with different business model options are identified. This methodology leads to the development of a series of multi-criteria decision-making (MCDM) panels to define a set of practical criteria suitable for a final MCDM for the identification of triticale-based biorefinery alternatives leading to long-term and sustainable business models. © 2018 Society of Chemical Industry and John Wiley & Sons, Ltd

**Keywords:** biorefinery; business model; triticale, decision making

## Introduction

In the emerging era of the bio-based economy, key issues such as volatile energy prices, global warming, and greenhouse gas (GHG) emissions reduction targets, government energy policy, and economic disruptions are

influencing the decision making of industry and government institutions involved in biorefinery investment strategies. Furthermore, making rational biorefinery investment choices depends on knowledge about issues such as feedstock access, emerging bioprocesses, bioproducts, and new bioproduct markets.<sup>1</sup> For investors, a sustainable

competitive position over the long term is sought, and evaluating the likelihood of reaching this ambitious objective is far from obvious considering the many biorefinery design options available, each of which implies different risks, involves different process technologies, and yields different economic returns. Increased competition for access to feedstock, optimization of the existing business model, and value creation and maximization are critical biorefinery investment drivers. Issues such as greenfield versus retrofit implementation, agricultural versus other biomass feedstock such as algae or forest, and commodity-driven versus value-added-oriented bioproduct portfolios further contextualize the investment decision at hand.<sup>2</sup> For instance, from the perspective of the agricultural biorefinery, the gross value per hectare that addresses the switching costs from existing cultivation to biorefinery crops, as well as the use of all components of the crop to remain profitable on a per-hectare basis governs investment decision making.<sup>3</sup> From a farmer's perspective, the biorefinery value proposal should contribute to mitigating the risk of dedicating crops to one specific business opportunity, while providing a premium for the sale of agricultural by-products such as straw. From the investor's perspective, the biorefinery value proposal should enable the creation and capture of value over the longer term, while mitigating procurement, technology, and market risks. For instance, volatility in biomass prices due to the tight relationship between crop supply and demand as well as changes in production practices may increase the economic and commercial uncertainty around the agricultural biorefinery.<sup>4</sup>

Financial and capital performance metrics such as return on investment (ROI) or internal rate of return (IRR) are typically used for capital spending decisions but have certain limitations when considering strategic biorefinery investment. Hytönen *et al.*<sup>5</sup> emphasized the importance of a more thorough analysis of the process and economic risks associated with a specific biorefinery technology, along with the business transformation potential that the project may imply. This means that more than one project evaluation criterion should be considered<sup>6</sup> to quantify more accurately the underlying risks and uncertainties of different capital spending scenarios by incorporating information from an advanced cost accounting method such as activity-based costing (ABC).<sup>7,8</sup> On the topic of technology risks, Cohen *et al.*<sup>9</sup> discussed a methodological framework and a set of decision-making criteria related to the evaluation of a range of biorefinery technology strategies before detailed engineering analysis. In this approach, multi-disciplinary decision-making criteria were defined to support the evaluation of the economic

and environmental profile of different technologies, and the associated competitive position from biomass and product portfolio perspectives. Using such a multi-disciplinary perspective to address investment decision making at the business-model development level is not yet a common approach. The competitive position of the product portfolio, the robustness of the business strategy in the face of volatility in demand and prices, and the potential of the technology strategy to support the development of the business strategy are some of the key success factors that should be defined and considered when evaluating an investment opportunity.<sup>10</sup> As part of a sustainability approach, the environmental impacts associated with various biorefinery options are generally characterized using life-cycle assessment (LCA), which leads to the quantification of different environmental aspects.<sup>11</sup> The complete spectrum of environmental impact categories should be refined to a set of necessary and sufficient indicators to enable decision making in a specific biorefinery context.<sup>12</sup>

The objective of this paper is to introduce a risk-based methodology that uses a multi-disciplinary approach for investment decision-making about product/process biorefinery alternatives. Based on the multi-criteria decision-making (MCDM) framework, the methodology provides a definition of a set of necessary and sufficient criteria, which are suitable for assessing the sustainability of various biorefinery investment strategies.

The triticale (*X Triticosecale Wittmack*) biorefinery is presented as a case study. Triticale is a human-developed crop resulting from the breeding of wheat and rye and having the potential to become a major industrial crop platform. Triticale's competitive advantages against other crops have been demonstrated, including a potential of 20% higher yield than Canadian Prairie Spring (CPS) wheat, higher biomass and starch content than other crops, good agronomics on marginal soil, lack of competition for food and feed applications, and a good prospect for genetic modifications for improved trait expression.<sup>13</sup> Triticale offers potential for use as a feedstock for biofuel production<sup>14,15</sup> at a cost per tonne lower than feed wheat.<sup>16</sup> Principally in Alberta, 76 000 acres of triticale have been reported, of which 15 000 acres are harvested as grain, while the remainder of the crop is used primarily for silage and pasture, often in combination with other crops. Conversion of the land these other crops occupy to triticale cultivation could potentially increase the total acreage by approximately 300 000 acres.<sup>17</sup> Triticale development in Alberta is part of a shift in land use from cereals to canola. Continued research

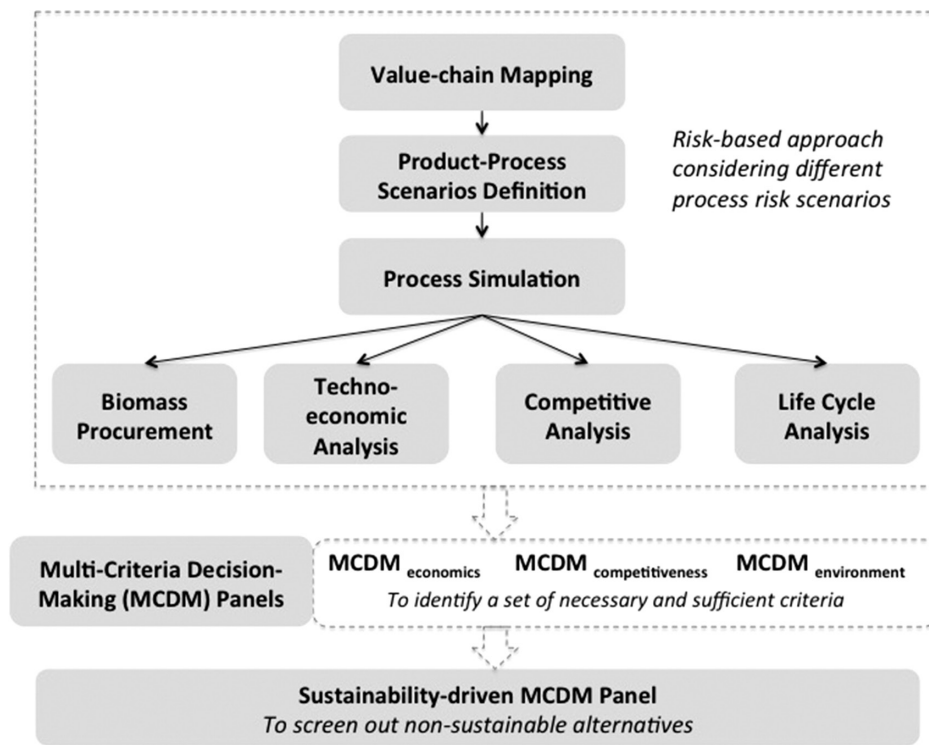

Figure 1. Stage-wise multi-criteria decision-making methodology.

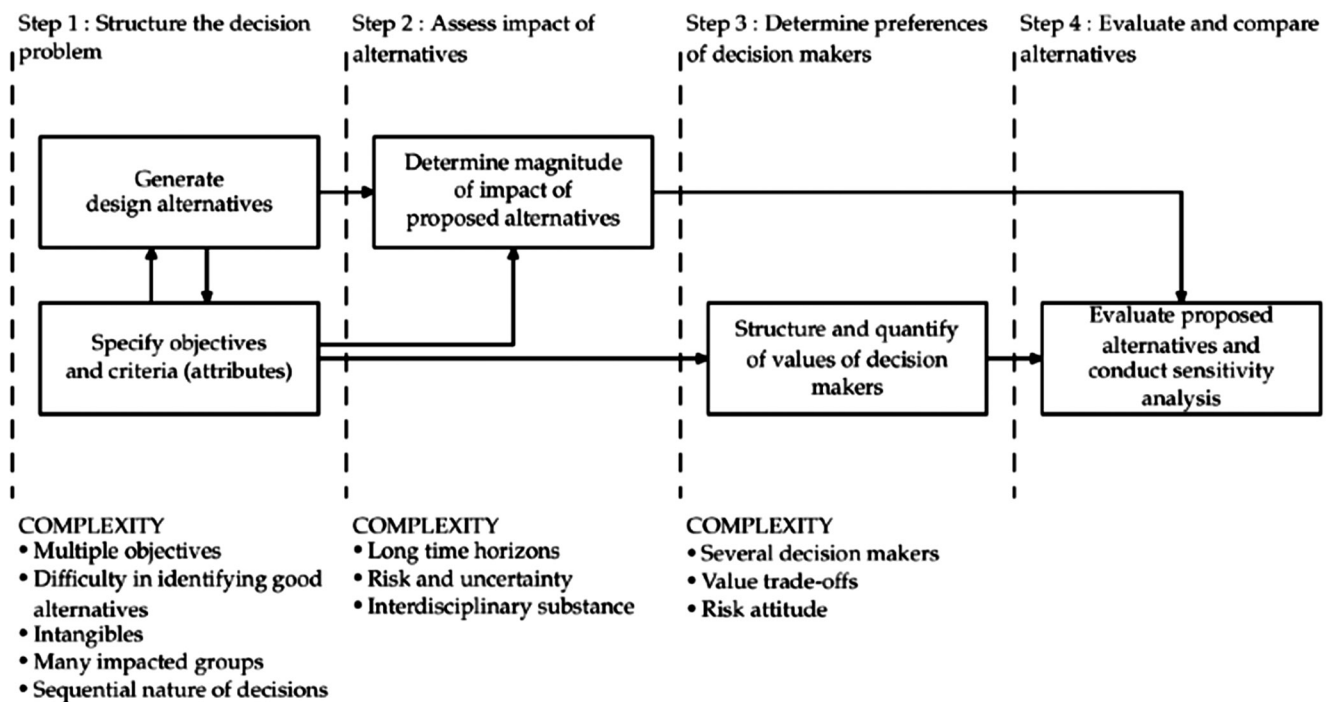

Figure 2. Schematic representation of the steps in decision analysis.<sup>23</sup>

into triticale productivity improvement and safety and nutrition aspects is critical for the future competitiveness of the crop.

The hypothetical case of a greenfield biorefinery implementation near Red Deer, Alberta, has been investigated in this research. This strategic location is based on potential access

to a large volume of biomass and to the existing petrochemical and chemical value chains in the region. Three investment strategies involving different product/process platform scenarios were developed: (1) production of commodities such as ethanol, (2) production of value-added chemicals such as polylactic acid (PLA), and (3) production of biomaterials such as thermoplastic starch (TPS) and biocomposites. Each product/process platform implies different levels of technology risks and uncertainties. A biomass supply-chain procurement model was developed to account for the logistical requirements related to harvesting and transportation of both grain and straw to the biorefinery.<sup>18</sup> The case study lays the groundwork for a deeper analysis of the economic, competitive, and environmental profile of each alternative with the intent of identifying a sustainable business model.

## Investment decision-making for the biorefinery

### Biorefinery investment potential

For investors seeking to implement a biorefinery project, business model outcomes over the longer term should be the drivers for setting short- and mid-term product/process strategies. A broad range of emerging technologies with different level of associated risks and uncertainties can be considered, leading to a large slate of product options, ranging from chemical building blocks to value-added chemicals.<sup>19</sup> Depending on the investors' business vision, different technological, commercial, financial, and partnership strategies might be identified.<sup>20</sup> Chambost *et al.*<sup>1</sup> developed a phased approach that recommends the incremental implementation of a biorefinery strategy including identification of a flexible product portfolio and the best associated technology strategy. What is the optimal product portfolio that will lead to long-term competitive advantages on the market, and for which supply chain

can synergies be defined? What emerging technologies (biochemical, thermochemical, or chemical) will enable new product portfolio development while providing the targeted return on investment and mitigating risks? The investment challenge does not lie only in the choice of technology and the maturity of the process selected. Even more important is identifying promising markets for commodity or specialty chemicals or both, considering the potential for replacement and/or substitution and their associated risks.<sup>21</sup> Through the development of a value-chain approach, Batsy *et al.*<sup>22</sup> suggested that competitive advantages should be maximized through development of: (1) robust product portfolios, (2) access to a large volume of low-cost biomass, (3) collaborative market penetration strategies, and (4) supply-chain synergies and manufacturing flexibility to react better to market price fluctuations.

### Methodology for sustainable business model development

In the context of investment in the triticale-based biorefinery, a stage-wise MCDM approach is presented here for assessing the sustainability of various product/process investment options (Fig. 1).

### Risk-based approach

Replacement and substitute products are identified primarily on the basis of an evaluation of existing and local value chains. Base-case scenarios and alternatives are generated assuming either conventional (base-case) or emerging processes, each leading to different levels of technology and commercial risks and uncertainties. The base case is used as a benchmark to determine the economic potential associated with higher risk alternatives. The scenarios are modeled from the farmer's field where the biomass is harvested to the distribution of the products on the market.

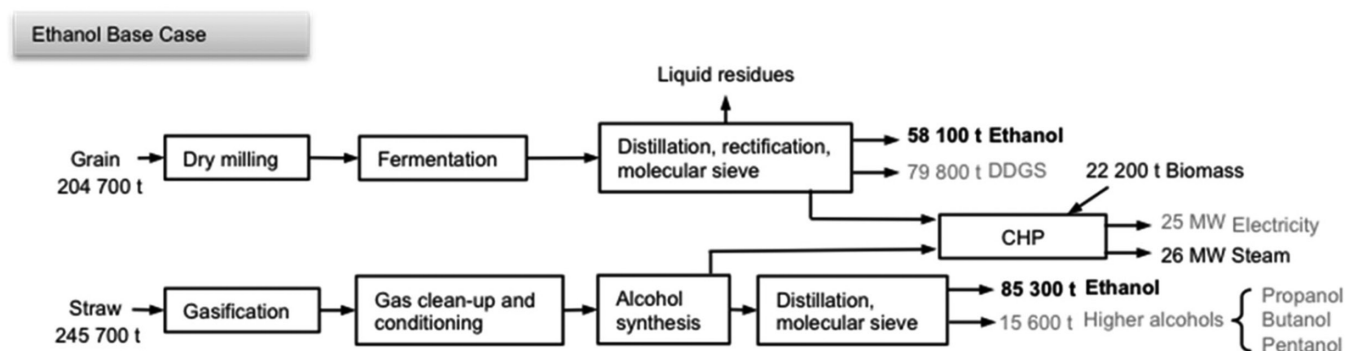

Figure 3. Ethanol base case.

Preliminary mass and energy balances are generated based on a targeted production rate for the main product and are used for techno-economic, environmental, and competitive analysis as well as to develop biomass procurement strategies. A series of multi-disciplinary analyses are then conducted, including (1) a competitiveness assessment of each product portfolio to identify the potential of each alternative for value creation and maximization,<sup>11</sup> (2) a techno-economic assessment to evaluate the economic feasibility of each biorefinery design strategy,<sup>6</sup> (3) a biomass procurement analysis to determine supply-chain characteristics and models for each alternative,<sup>17</sup> and (4) LCA to quantify the potential environmental impacts of each alternative.<sup>13</sup> The results of sensitivity analyses associated with key risks are considered, as well as the potential for crop productivity increases.

## Multi-criteria decision making

Decision analysis can be defined as “the formalization of common sense for decision problems which are too complex for informal use of common sense” and consists of four steps,<sup>23</sup> as shown in Fig. 2. First, the decision problem is structured by specifying the objectives, criteria, attributes of each of these, and alternatives. Second, the possible impact of each alternative is assessed. Third, the

preference of the decision-makers is elicited by determining decision weights and utility functions for each of the criteria. The resulting utility functions are rules by which this assignment is carried out and depend on the preferences of a single decision-maker over a range of attribute values. Finally, the alternatives are compared and evaluated, and a sensitivity analysis is carried out.

For the purpose of the present methodology and its application to the triticale-based case study, a trade-off method<sup>24</sup> was used to weight the decision criteria. To define the trade-off attribute values for calculating the decision weights, the decision makers are first asked to determine the most important decision criterion and then to establish the trade-off attribute values between this criterion and all the other criteria for calculating decision weights ( $W_i$ ).<sup>25</sup> A unique score ( $SC_i$ ) is determined for each alternative using  $W_i$  and the calculated utility value ( $U_i$ ) associated with each alternative:

$$SC_e = \sum_{i=EC1}^{EC6} W_i \cdot U_i \quad (1)$$

Based on the various design analyses, key criteria are identified to assess the sustainability of each investment option. A series of three MCDM panels focusing on (1)

**Table 1. Product/process alternatives for ethanol production.**

Alternative	Key objectives	Major characteristics
1	Evaluate the impacts of producing green electricity as a major co-product. → Under what market conditions is electricity a more profitable co-product?	<ul style="list-style-type: none"> <li>All straw is sent to the CHP unit.</li> <li>The CHP unit is less capital-intensive and implies lower technological risk.</li> <li>Steam and electricity are generated.</li> <li>Steam is used in the process, and excess electricity is sent to the grid.</li> </ul>
2	Assess the potential increase in marginal profit of the process associated with the production of a protein, i.e., an extra value-added product. → How will the business model be impacted?	<ul style="list-style-type: none"> <li>Replacement of dry milling by wet milling leads to the production of protein instead of the stillage residues used in the mill feed.</li> <li>80% of the protein in the grain can be extracted using wet fractionation by an alkaline agent.</li> </ul>
3	Assess under what conditions the biochemical production of ethanol and value-added products (i.e., xylitol) from straw is economically feasible. → How would this impact the purity of ethanol on the straw line?	<ul style="list-style-type: none"> <li>Pre-treatment of straw using pressurized low-polarity water (PLPW)<sup>29</sup> followed by simultaneous saccharification and fermentation (SSF).<sup>30</sup></li> <li>The C<sub>5</sub> sugars are used for the production of xylitol.</li> </ul>
4	Assess the impacts of a membrane separation process. → Would the use of membrane separation lead to a product with higher purity that may impact the business model?	<ul style="list-style-type: none"> <li>The membranes used in the separation process (pervaporation) lead to a significant decrease in capital costs and energy use</li> <li>Pervaporation fermentation<sup>31</sup> (hybrid followed by a molecular sieve) changes the fermentation from a batch to a continuous process.</li> </ul>
5	Evaluate the impacts of producing bran and stillage. → How does this product mix perform compared to dried distillers' grains with solubles (DDGS)?	<ul style="list-style-type: none"> <li>Pearling<sup>32</sup> in the grain line results in the production of bran and stillage.</li> </ul>

**Table 2. Mass and energy balances for the production of 40 Mgal ethanol per year.**

Ethanol platform	Grain	Straw	Additional straw to CHP	Mixed alcohol	DDGS	Millfeed	Protein	Xylitol	Bran	Stillage	Steam consumption (MW)	Electricity consumption (MW)	Excess electricity (MW)
All values in 1000s tonnes per year													
Base case	205	245	22	15	80	—	—	—	—	—	26	5	25
Alt 1	505	606	—	—	197	—	—	—	—	—	40	5	93
Alt 2	221	265	7	17	—	66	34	—	—	—	31	8	22
Alt 3	320	384	0,5	—	125	—	—	60	—	—	40	9	21
Alt 4	218	261	1	16	85	—	—	—	—	—	14	5	25
Alt 5	230	276	13	17	—	—	—	—	34	64	26	5	25

competitiveness, (2) economic,<sup>6</sup> and (3) environmental<sup>12</sup> criteria was conducted to validate the interpretation of each criterion and to identify the panelists' preferences among the criteria to be used for decision making. These panelists were experts in the field of the biorefinery, and had various backgrounds. This ensured that the analyzed strategies were considered from different perspectives. These activities led to the identification of a set of necessary and sufficient criteria that were used in a final sustainability-driven MCDM panel, leading to the identification of promising sustainable alternatives.<sup>26</sup>

## Results

### Case study context

The following case study features triticale as a potential industrial crop platform for bio-product development. An increase in productivity has been pointed out as the cornerstone of the success of triticale as a feedstock for biorefining in Canada, along with its other competitive advantages compared to cereal grains in terms of yield, disease resistance, and starch-to-fiber ratios. The objectives of the case study were the following: (1) to determine the conditions under which triticale biorefinery scenarios are economically and environmentally viable, and (2) to assess the strengths and weaknesses of different product/process scenarios featuring different levels of risks and different product portfolio potentials. A greenfield implementation near Red Deer, Alberta, has been investigated. Three product platforms were considered: (1) ethanol, (2) PLA, and (3) TPS/PLA polymer blend. Each of these platforms features a base case and various product/process alternatives. The base case involves use of the most conventional processes in the grain line, i.e., minimum technology risks as well as minimum capital costs implied, while using the most advanced conversion processes in the straw line. The alternatives involve different levels of technological complexity and risks in both the grain and straw lines, from which higher returns are expected. The definition of each alternative is driven by maximization of production of the main product, i.e., ethanol, PLA, or TPS/PLA.

A biomass procurement model was defined to support the identification of strategic opportunities to deliver the right amount of grain and straw to the biorefinery at a minimum procurement cost.<sup>16</sup> Certain key assumptions were used to develop the model, such as (1) the wheat supply chain is the *current case*, (2) biomass losses are reduced throughout the procurement process, (3) a *farmer*

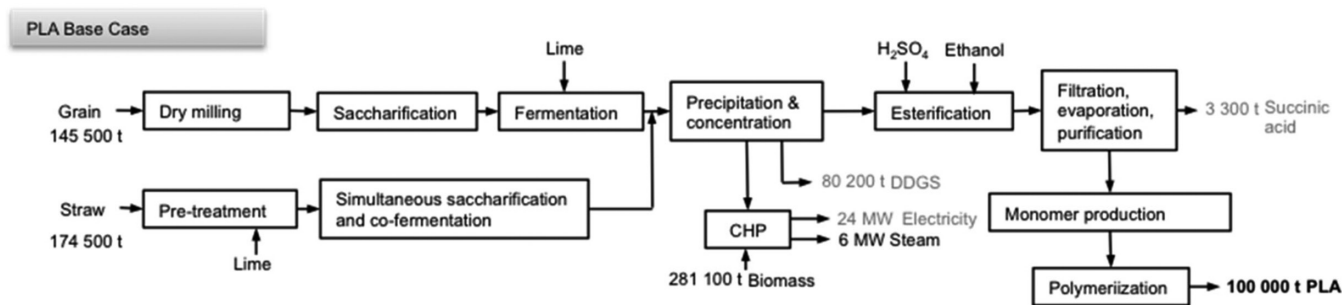

Figure 4. PLA base case.

*participation rate* is defined for access to grain and straw, (4) triticale yields vary between 1.1 and 1.8 mt/acre in Alberta.<sup>15</sup> The procurement model supports the identification of a value proposal for the farmers to support the switch from other cereals to triticale.

## Triticale-Based Product/Process Alternatives

For the purposes of this analysis, the following major assumptions were made: (1) to ensure environmental benefits, 20% of straw is left on the land after harvest,<sup>12,18</sup> (2) triticale straw is assumed to be similar to wheat straw, (3) the steam produced is used in the plant, whereas excess electricity is sent to the grid, and, in some cases, (4) extra biomass is used to maximize electricity production into the CHP unit.

## Ethanol platform

As shown in Fig. 3, the Husky process,<sup>27</sup> which has been commercialized in Western Canada, is assumed for the production of ethanol from cereal grain as the base case with a capacity of 40 million gallons per year, i.e., 143,400 t/y. Although it is not yet a mature technology, the gasification process is used in the straw line, followed by mixed-alcohol synthesis.<sup>28</sup>

Five alternatives are defined in Table 1, all involving the same ethanol yield, but with different levels of risk associated with the technology and with a different product portfolio potential.

Alternatives 1 and 3 require a large volume of biomass; however, significant volumes of electricity and xylitol respectively are produced. The returns on investment and the competitive positions in the market may be attractive but will be different. Technology risks (i.e. technology maturity level and technology complexity compared to the base case) associated with alternative 3 are greater but should be mitigated by higher returns. Alternative

2 implies a standard technology shift and may lead to a higher risk-reward ratio than alternative 3 with the production of protein. Alternative 4 involves a higher risk and is a capital-intensive technology, although ethanol purity is not necessarily a critical factor for business success in a commodity market. Table 2 illustrates mass and energy balances for the production of 40 Mgal ethanol per year.

## PLA platform

The PLA base case (Fig. 4) with a capacity of 100 000 metric tonnes per year involves (1) a commercialized process from NatureWorks LLC<sup>33–36</sup> on the grain line and (2) the Iogen pre-treatment<sup>37</sup> followed by SSCF on the straw line. Besides PLA, the base case also produces succinic acid, DDGS, and electricity.

Lime is used as a neutralizing agent for producing lactic acid in the grain line and as an enhancer for the conversion of hemicellulose to sugars in the straw line. The concentration, separation, and purification of lactic acid and succinic acid from the broth are carried out using a conventional process based on esterification and distillation. The five product/process alternatives are defined in Table 3.

As shown in Table 4, the amounts of biomass used in each alternative are of the same order of magnitude. The technology used in each alternative is therefore the main differentiator and determines which chemicals are produced besides the main product. Only the base case and Alternative 4 have the same product portfolio despite the use of different technologies in the straw line (thermochemical and biochemical respectively).

## TPS/PLA polymer blend platform

The base case uses a well-established thermoplastic starch (TPS) production process and assumes the production of a 40%–60% TPS/PLA polymer blend (<http://entek.com/extruders/>)<sup>39</sup> to reach a production of 75 000 t of this blend per year based on 30 000 t TPS produced (Fig. 5). Through

**Table 3. Product/process alternatives for PLA production.**

Alternative	Key objectives	Major characteristics
1	Similar to the ethanol platform (Table 1)	<ul style="list-style-type: none"> <li>• Similar to the ethanol platform (Table 1)</li> </ul>
2	Similar to the ethanol platform (Table 1)	<ul style="list-style-type: none"> <li>• Similar to the ethanol platform (Table 1)</li> <li>• PLA production decreases due to starch loss</li> </ul>
3	Assess the impacts associated with a more efficient separation process → How may the production of acetic acid as co-product improve economic performance?	<ul style="list-style-type: none"> <li>• Replacement of the filtration process by an ultra-filtration and electro dialysis process<sup>38</sup></li> <li>• More efficient separation process that yields acetic acid</li> <li>• Elimination of gypsum production</li> </ul>
4	Evaluate the economic impact of intensification of the grain line → Would higher product quality and volumes be achieved?	<ul style="list-style-type: none"> <li>• An SSF process replaces the separate saccharification and fermentation process steps</li> </ul>
5	Similar to the ethanol platform (Table 1)	<ul style="list-style-type: none"> <li>• Similar to the ethanol platform (Table 1)</li> </ul>

**Table 4. Mass and energy balances for the production of 100,000 t/y of PLA.**

PLA platform	Grain	Straw	Additional straw to CHP	DDGS	Millfeed	Stillage	Succinic acid	Protein	Acetic acid	Bran	Steam consumption (MW)	Electricity consumption (MW)	Excess electricity (MW)
Base case	145	174	281	80	—	—	3	—	—	—	128	6	24
Alt 1	235	282	324	103	—	—	3	—	—	—	120	6	63
Alt 2	142	170	307	—	73	—	3	22	—	—	131	8	22
Alt 3	145	174	253	85	—	—	3	—	1	—	108	7	23
Alt 4	139	167	309	81	—	—	3	—	—	—	108	5	25
Alt 5	143	172	321	—	—	67	3	—	—	21	126	7	23

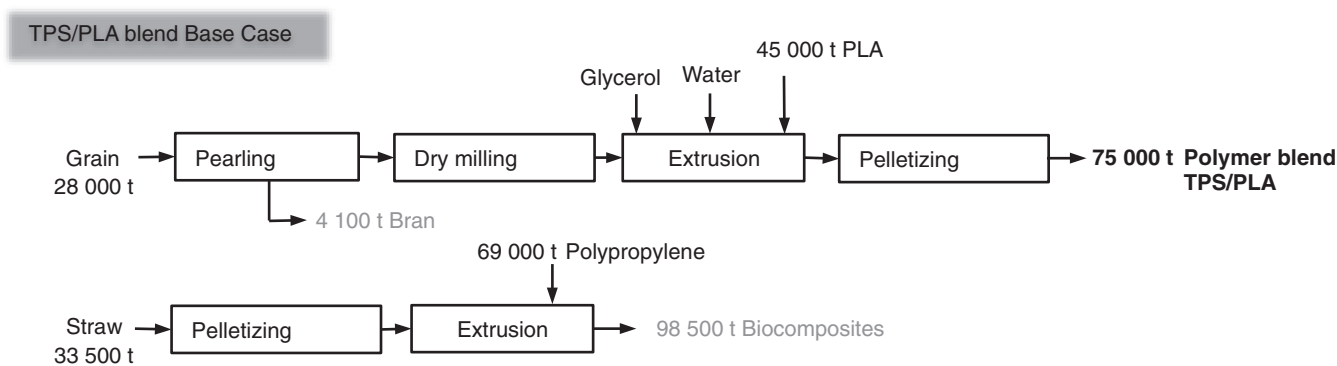

Figure 5. TPS/PLA base case.

**Table 5. Product/process alternatives for TPS/PLA polymer blend production.**

Alternative	Key objectives	Major characteristics
1	Similar to the ethanol platform (Table 1)	<ul style="list-style-type: none"> <li>• Similar to the ethanol platform (Table 1)</li> </ul>
2	Similar to the ethanol platform (Table 1) → How would protein extraction impact the TPS/PLA blend quality, and would it open new niches in the market?	<ul style="list-style-type: none"> <li>• Similar to the ethanol platform (Table 1)</li> <li>• More grain is needed to produce the same volume of polymer blend</li> </ul>
3	Assess the impact of pre-treating the straw and using pure cellulose as filler in biocomposites → How would this impact the properties of the biocomposites and the associated business case?	<ul style="list-style-type: none"> <li>• Mechanical pulping used to extract cellulose from straw fiber</li> <li>• Capital-intensive if not integrated into an existing mechanical pulp mill</li> </ul>

the pearling process, a starch purity of 60% is achieved. The straw is used to produce biocomposite pellets (at a fiber-to-polypropylene ratio of 30:70) using the Entek process (Entek, <http://www.entek-mfg.com>) for the production of panels for the construction sector.

Three alternatives were identified (see Table 5), which imply higher technology risks as well as the development of new product portfolios.

Alternatives 1 and 3 use significantly more biomass than the base case and than alternative 2 because electricity is produced in the CHP unit (Table 6). Nevertheless, alternative 2 has a more diverse product portfolio than alternative 1. Depending on the market value of the products, this may have a significant impact on the competitiveness of the alternatives.

## Discussion

### Preliminary economic review of triticale alternatives

Which triticale biorefinery strategy will lead to a sustainable and long-term business model supporting cost-competitiveness advantages against other crops such as wheat?

The triticale biorefinery offers potential for good IRR, but in certain cases, the IRR can be enhanced using higher risk technologies. The case of the ethanol platform speaks for itself. Except for alternative 3, none of the alternatives reached the 20% IRR threshold for justifying capital investment; most of them achieved an IRR of approximately 9%.<sup>6</sup> The highest technology risks are associated with the implementation of the PLPW technology in alternative 3; however, higher margins can be achieved by sale of xylitol on the market. In the cases of the PLA and TPS/PLA blend platforms, the IRRs are higher than the threshold. Only two alternatives, alternative 1 for the PLA platform and alternative 3 for the TPS/PLA platform respectively, do not present promising economic returns because they use capital-intensive processes. In all cases, the procurement strategy is a key driver for economic success. For instance, in the case of commodities production, more than 50% of the variable production costs can be attributed to biomass raw materials.

Solely on the basis of economic viability, identifying the preferred alternative under each platform is not obvious. The biorefinery implementation must be sustainable over the longer term, and decisions should not be made on the basis of short-term returns alone. Market and environmental considerations should be considered, as well as key

**Table 6. Order-of-magnitude mass and energy balances for the production of 75 000 t/y TPS/PLA polymer blend.**

TPS/PLA platform	Grain	Straw	Additional straw to CHP	TPS	TPS/PLA	Biocomposites	Bran	Protein	Millfeed	Steam consumption (MW)	Energy consumption (MW)	Excess electricity (MW)
All values in 1000s tonnes per year												
Base case	28	33	—	30	75	98	4	—	—	40	63	—
Alt 1	28	33	261	30	75	—	4	—	—	17	30	0
Alt 2	34	41	—	30	75	121	5	4	1,5	47	91	—
Alt 3	28	34	211	30	75	84	4	—	—	39	60	0

issues such as the potential impacts of triticale productivity, carbon credits, and capital-cost subsidies on the economic, competitive, and environmental profiles of the alternatives.

## Towards decision making

The methodology presented in this paper underlines the necessity of incorporating variables other than economic returns in the decision-making process for a more sustainable business model:

- Market competitive analysis is essential to ensure business-plan development for the long term and to determine which product portfolio combinations maximize competitive advantage. Part of this analysis involves the incorporation of advantages related to competitive access to biomass. In the context of the triticale biorefinery and the existing competition for biomass access, being able to generate reasonable margins per tonne of biomass should be considered as a long-term competitive advantage to secure the procurement strategy.
- LCA-based environmental analysis is essential to ensure that the biorefinery processes are environmentally sound. The question to be investigated involves the potential of each platform to present a positive environmental profile while performing economically and competitively.

The MCDM approach presented in the methodology is the appropriate decision-making tool for (1) determining the key criteria that will influence the decision from different perspectives, and (2) identifying the preferred biorefinery alternatives while considering the set of refinery criteria.

## Conclusions

Sustainability is of critical importance for the long-term implementation of the triticale biorefinery, and a value-chain approach is needed to define a value proposal extending from the farmer to the biorefinery. From an investor's perspective, obtaining a good return is the main driver. However, investing in the biorefinery is not an unconstrained problem, and decisions should be made on the basis of which product and which process will lead to sustainable returns. The risk-based approach presented in this paper makes this decision possible through the definition of a base case and alternatives and the identification of a trade-off between risks and benefits. By use of MCDM, balanced decision making is achieved using a small number of interpretable multi-disciplinary criteria. Three MCDM panels

were conducted using the case study presented in this paper and focusing on the identification of a set of necessary and sufficient criteria for decision-making based on preliminary economic, competitive, and environmental analysis of each alternative.<sup>6,8</sup> A sustainability-focused MCDM was subsequently executed, based on the case of PLA production using a set of necessary and sufficient criteria for decision making regarding the most sustainable PLA alternatives incorporating economic, competitive, and environmental concerns for the same investment objective.<sup>21</sup>

## Acknowledgements

This study has been funded by the Canadian Triticale Biorefinery Initiative (CTBI). The authors would like to thank the CTBI Network researchers who helped with data collection.

## References

- Chambost V, McNutt J and Stuart PR, Guided tour: Implementing the forest biorefinery at an existing pulp and paper mill. *Pulp Pap Can* **109**:19–27 (2008).
- Janssen M and Stuart PR, Drivers and barriers for implementation of the biorefinery. *Pulp Pap Can* **111**:13–17 (2010).
- Sanders J, Scott E, Weusthuis R and Mooibroek H. The bio-refinery as the bio-inspired process for bulk chemicals. *Macromol Biosci* **12**(2):105–117 (2007).
- Bennett S, Green biorefineries. *Cleantech Magazine* **2**:15–16 (2008).
- Hytönen E and Stuart PR, Capital appropriation for the forest biorefinery. *Pulp Pap Int* **53**(10):23–32 (2011).
- Sanaei S and Stuart PR, Systematic assessment of triticale-based biorefinery strategies: Techno-economic analysis to identify investment opportunities. *Biofuels, Bioprod Bioref* **12**(Suppl. 1):S46–S59 (2018).
- Laflamme-Mayer M, Janssen M and Stuart P, Development of an operations-driven cost model for continuous processes – Part I: Framework for design and operations decision making. *J-FOR* **1**:32–41 (2011).
- Janssen M, Naliwajka P and Stuart P, Development of an operations-driven cost model for continuous processes – Part II: Retrofit process design application. *J-FOR* **2**:43–54 (2012).
- Cohen J, Janssen M, Chambost V and Stuart PR, Critical analysis of emerging forest biorefinery (FBR) technologies for ethanol production. *Pulp Pap Can* **111**(3):26–30 (2011).
- Diffó Téguia C, Chambost V and Stuart PR, Systematic assessment of triticale-based biorefinery strategies: Market competitive analysis for business model development. *Biofuels, Bioprod Bioref* **12**(Suppl. 1):S35–S45 (2018).
- Dinca C, Badea A, Rousseaux P and Apostol T, A multi-criteria approach to evaluate natural gas energy systems. *Energy Policy* **35**(11):5754–5765 (2007).
- Liard G, Amor B, Leasage P, Stuart P and Réjean S, Selection of LCA-based environmental criteria for multi-criteria decision support in a biorefinery context. SETAC Europe 21st Annual Meeting, Milano (2011).
- Beres BL, Harker KN, Clayton GW, Bremer E, Blackshaw RE and Graf RJ, Weed-competitive ability of spring and winter cereals in the northern Great Plains. *Weed Technol* **2**:108–116 (2010).
- Buck M and Senn T, Energy self-sufficient production of bioethanol from a mixture of hemp straw and triticale seeds: life-cycle analysis. *Biomass and Bioenergy* **95**:99–108 (2016).
- Agudelo RA, García-Aparicio MP and Görgens JF, Steam explosion pretreatment of triticale (*x* Triticosecale Wittmack) straw for sugar production. *New Biotechnology* **33**(1):153–163 (2016).
- Bergstra R, *Triticale: A Value Proposal as a Bio-Industrial Feedstock*. MTN Consulting Associates for Triticale Biorefinery Initiative and Alberta Crop Innovation and Development Fund (2008).
- IMC (Ian Murray and Company Ltd), *Canadian Triticale Biorefining Initiative: Producer Value Proposition*. Alberta Agriculture and Rural Development (2008).
- Melendez J and Stuart PR, Systematic assessment of triticale-based biorefinery strategies: A biomass procurement strategy for economic success. *Biofuels, Bioprod Bioref* **12**(Suppl. 1):S21–S34 (2018).
- Werpy T and Peterson G, *Top Value-Added Chemicals from Biomass Feedstock, Volume I: Results of Screening for Potential Candidates from Sugars and Synthesis Gas*. National Renewables Laboratory (NREL), for US Department of Energy (2004).
- Janssen M, Chambost V and Stuart PR, Successful partnership for the forest biorefinery. *Ind Biotechnol* **4**(4):352–362 (2008).
- Sammons Jr, NE, Yuan W, Eden MR, Aksoy B and Cullinan HT, Optimal biorefinery product allocation by combining process and economic modeling. *Chem Eng Res Des* **86**(7):800–808 (2008).
- Batsy DR, Solvason CC, Sammons NE, Chambost V, Bilhartz DL, Eden MR *et al.*, Product portfolio selection and process design for the forest biorefinery, in *Integrated Biorefineries: Design, Analysis, and Optimization*, ed. by Stuart PR and El-Halwagi MM. CRC Press, Boca Raton, FL, pp. 3–35 (2012).
- Keeney RL, Decision analysis: an overview. *Oper Res* **30**(5):803–838 (1982).
- Niekamp S, Bharadwaj UR, Sadhukhan J and Chryssanthopoulos MK, A multi-criteria decision support framework for sustainable asset management and challenges in its application. *Int J Ind Prod Eng Tech* **32**(1):23–36 (2015).
- Keeney RL and Raiffa H, *Decisions with Multiple Objectives: Preferences and Value Trade-Offs*. Cambridge University Press, Cambridge MA (1976).
- Sanaei S, Chambost V and Stuart PR, Systematic assessment of triticale-based biorefinery strategies: Sustainability assessment using multi-criteria decision-making (MCDM). *Biofuels, Bioprod Bioref* **12**(Suppl. 1):S73–S86 (2018).
- Freem P, Husky to build new ethanol plant in Lloydminster. *Canadian Oil and Gas Review* (2010).
- Phillips S, Techno-economic analysis of a lignocellulosic biomass indirect gasification process to make ethanol via mixed alcohols synthesis. *Ind Eng Chem Res* **46**:8887–8897 (2007).
- Pronyk C and Mazza G, Optimization of Processing Conditions for the Fractionation of Triticale Straw Using Pressurized Low-Polarity Water. *Bioresour Technol* **102**:2016–2025 (2011).

30. Hofvendahl K, Åkerberg C, Zacchi G and Hahn-Hägerdal B, Simultaneous enzymatic wheat starch saccharification and fermentation to lactic acid by *Lactococcus lactis*. *Appl Microbiol Biotechnol* **52**:163–169 (1999).
31. Vane LM, Separation technologies for the recovery and dehydration of alcohols from fermentation broths. *Biofuels, Bioprod Bioref* **2**(6):553–588 (2008).
32. Vasanthan T and Temelli F, Grain fractionation technologies for cereal beta-glucan concentration. *Food Res Int* **41**(9):876–881 (2008).
33. Vink E, Glassner DA, Kolstad JJ, Wooley RJ and O'Connor RP, Ecoprofiles for current and near-future NatureWorks® polylactide (PLA) production. *Ind Biotechnol* **3**:58–81 (2007).
34. Maas R, Bakker R, Jansen M, Visser D, Jong E, Eggink G *et al.*, Lactic acid production from lime-treated wheat straw by *Bacillus Coagulans*: neutralization of acid by fed-batch addition of alkaline substrate. *Appl Microbiol Biotechnol* **78**:751–758 (2008).
35. Saha BC and Cotta MA, Enzymatic hydrolysis and fermentation of lime pretreated wheat straw to ethanol. *J Chem Technol Biotechnol* **82**:913–919 (2007).
36. Cockrem MCM and Johnson PD, Recovery of lactate esters and lactic acid from fermentation broth. US Patent 5210296 (1993).
37. Aden A and Foust T, Technoeconomic analysis of the dilute sulfuric acid and enzymatic hydrolysis process for the conversion of corn stover to ethanol. *Cellulose* **16**:535–545 (2009).
38. Rathin D and Glassner D, Process for production and purification of lactic acid No. EP0393818 (A1) (1990).
39. Huneault MA and Li H, Morphology and properties of compatibilized polylactide/thermoplastic starch blends. *Polymer* **48**:270–280 (2007).



#### Virginie Chambost

Virginie Chambost is co-founder and principal consultant at EnVertis Inc, a consulting services company dedicated to assisting the forest, agriculture, and allied sectors in identifying successful strategies for improving and/or transforming business models.

Her major contributions are related to the development of market- and risk-based methodologies supporting the identification of promising product portfolios, marketing pathways, and business plans for implementing the biorefinery. Virginie obtained her MBA in innovative project management at the University of Lyon in France.



#### Matty Janssen

Matty Janssen is a senior researcher (docent) at the division of Environmental Systems Analysis at Chalmers University of Technology. The focus of his research is on life-cycle assessment (LCA) of bio-based products (fuels, chemicals, materials) and on the LCA of technology that is in its early stages of development. He also teaches in the field of environmental systems analysis.



#### Paul R Stuart

Paul R Stuart is a professor in the Chemical Engineering Department at Polytechnique-Montréal. He addresses industry-driven problems in his research program using product and process design methodologies and systems analysis tools, targeting the forest product and agricultural sectors, and their transformation to new business models such as the biorefinery. Paul is a Fellow of the Pulp and Paper Technical Association of Canada (PAPTAC), a past president of the Canadian Society for Chemical Engineering (CSChE), and a Fellow of the Canadian Academy of Engineering (CAE).