



**CHALMERS**  
UNIVERSITY OF TECHNOLOGY

## **A review of the use of organic Rankine cycle power systems for maritime applications**

Downloaded from: <https://research.chalmers.se>, 2026-04-04 21:56 UTC

Citation for the original published paper (version of record):

Mondejar, M., Andreasen, J., Pierobon, L. et al (2018). A review of the use of organic Rankine cycle power systems for maritime applications. *Renewable and Sustainable Energy Reviews*, 91: 126-151. <http://dx.doi.org/10.1016/j.rser.2018.03.074>

N.B. When citing this work, cite the original published paper.

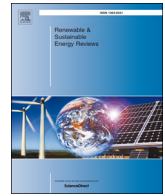

## A review of the use of organic Rankine cycle power systems for maritime applications



M.E. Mondejar<sup>a,\*</sup>, J.G. Andreasen<sup>a</sup>, L. Pierobon<sup>a</sup>, U. Larsen<sup>c</sup>, M. Thern<sup>b</sup>, F. Haglind<sup>a</sup>

<sup>a</sup> Department of Mechanical Engineering, Technical University of Denmark, Building 403, 2800 Kongens Lyngby, Denmark

<sup>b</sup> Department of Energy Sciences, Lund University, 221 00 Lund, Sweden

<sup>c</sup> Department of Shipping and Marine Technology, Chalmers University of Technology, 412 96 Gothenburg, Sweden

### ARTICLE INFO

#### Keywords:

Organic Rankine cycle  
Ship  
Marine  
Diesel  
Review  
Waste heat recovery

### ABSTRACT

Diesel engines are by far the most common means of propulsion aboard ships. It is estimated that around half of their fuel energy consumption is dissipated as low-grade heat. The organic Rankine cycle technology is a well-established solution for the energy conversion of thermal power from biomass combustion, geothermal reservoirs, and waste heat from industrial processes. However, its economic feasibility has not yet been demonstrated for marine applications. This paper aims at evaluating the potential of using organic Rankine cycle systems for waste heat recovery aboard ships. The suitable vessels and engine heat sources are identified by estimating the total recoverable energy. Different cycle architectures, working fluids, components, and control strategies are analyzed. The economic feasibility and integration on board are also evaluated. A number of research and development areas are identified in order to tackle the challenges limiting a widespread use of this technology in currently operating vessels and new-buildings. The results indicate that organic Rankine cycle units recovering heat from the exhaust gases of engines using low-sulfur fuels could yield fuel savings between 10% and 15%.

### 1. Introduction

Shipping is the primary means of transport worldwide. About 90% of the world trade is carried by sea [1]. The volume of seaborne trading is progressively growing, following the increment of the world population and economy. Besides its cost effectiveness, shipping is at present the most environmentally friendly and carbon efficient mode of transport, as it presents the lowest CO<sub>2</sub> emissions per metric ton of freight and per km of transportation [2]. Considering a medium-size cargo vessel, the carbon dioxide (CO<sub>2</sub>) emissions per kilometer to transport one tonne of goods are two times lower compared to a heavy-duty truck with trailer and twenty times lower compared to a cargo aircraft [1]. However, shipping is still responsible for an estimated 2.4% of the total global CO<sub>2</sub> emissions [3]. The shares of nitrogen oxides (NO<sub>x</sub>) and sulfur oxides (SO<sub>x</sub>) are about 15% and 13%, respectively, of the global emissions from anthropogenic sources [4].

More than 90% of large operating vessels use diesel engines fueled

by heavy fuel oil (HFO) as prime movers [5]. A significant potential to abate fuel consumption and pollutants still exists, considering that around 50% of the fuel energy content is dissipated as waste heat at various temperature levels. The International Maritime Organization (IMO) has recently enacted regulations to force the shipping industry to reduce emissions. Moreover, these regulations require the use of several performance indicators, such as the energy efficiency design index (EEDI), in order to enhance the energy conversion efficiency of new ships.

The most common approaches to reduce the fuel consumption in 2014 were slow steaming, optimization of the voyage, and cleaning of the hub and propeller [6]. The major criteria leading to a decision on which measure to adopt are the payback period, vessel age, and investment cost [6]. A complementary solution is the use of a waste heat recovery system (WHRS), i.e., a unit capable of converting the thermal energy discharged by the diesel engine into (electric or mechanical) power. The use of the steam Rankine cycle (SRC) technology for waste

**Abbreviations:** AIS, automatic identification system; CFC, chlorofluorocarbons; DME, dimethyl ether; DWT, deadweight tonnage; ECA, emission control area; EEDI, energy efficiency design index; EGR, exhaust gas recirculation; EU, European Union; GEN, generator; GWP, global warming potential; HCFC, hydrochlorofluorocarbons; HFO, heavy fuel oil, or hydrofluorolefins; HEX, heat exchanger; IMO, International Maritime Organization; ISO, International Organization for Standardization; KC, Kalina cycle; LNG, liquefied natural gas; MCR, maximum continuous rating; MDO, marine diesel oil; MGO, marine gas oil; MM, hexamethyldisiloxane; NO<sub>x</sub>, nitrogen oxides; NPV, net present value; ODP, ozone depletion potential; ORC, organic Rankine cycle; PT, power turbine; R&D, research and development; SMCR, specified maximum continuous rating; SOLAS, safety of life at sea; SO<sub>x</sub>, sulfur oxides; SP, Technical Research Institute of Sweden; SRC, steam Rankine cycle; TEU, twenty foot equivalent unit; TUR, turbine; WHR, waste heat recovery; WHRS, waste heat recovery system

\* Corresponding author.

E-mail address: [maemmo@mek.dtu.dk](mailto:maemmo@mek.dtu.dk) (M.E. Mondejar).

<https://doi.org/10.1016/j.rser.2018.03.074>

Received 20 April 2017; Received in revised form 23 March 2018; Accepted 24 March 2018

Available online 10 April 2018

1364-0321/ © 2018 The Authors. Published by Elsevier Ltd. This is an open access article under the CC BY-NC-ND license

(<http://creativecommons.org/licenses/by-nc-nd/4.0/>).

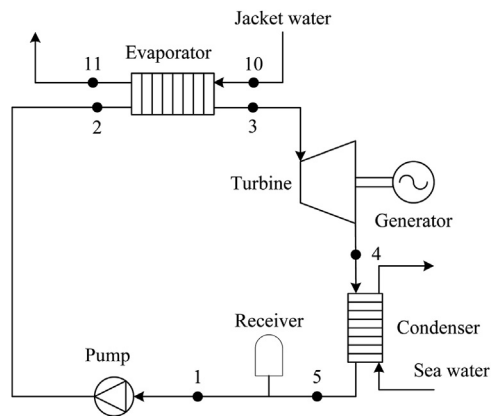

Fig. 1. Block diagram of an organic Rankine cycle power system recovering the heat from hot jacket water [9].

heat recovery (WHR) is well-established; however, its use for maritime applications is mostly limited to the utilization of heat sources of fairly high temperatures ( $> 250\text{ }^{\circ}\text{C}$ ).

A possible alternative is the use of organic Rankine cycle (ORC) systems. These units operate as a Rankine heat engine using an organic compound as the working fluid. This adds a degree of freedom (i.e., the working fluid) in the design phase which can be used to tailor the plant to the power capacity and temperature difference between the heat source and heat sink [7]. Furthermore, the thermophysical properties of organic fluids allow for manufacturing efficient expanders, especially at power capacities lower than a few megawatts [8]. Fig. 1 shows the diagram of an exemplary ORC power system harvesting the heat from the jacket cooling water of the main engine aboard a container ship (see Ref. [9]). The simplest layout of an ORC unit comprises the following components: evaporator, expander, condenser, liquid receiver and pump. A recuperator placed after the turbine may be added to preheat the fluid and thereby increase the energy conversion efficiency.

Today, the ORC technology is mainly used for the conversion of thermal power from biomass combustion, liquid-dominated geothermal reservoirs, and waste heat from industrial processes [8]. For the time being, only three ORC units have been tested aboard three ships, namely, an ORC unit on the merchant ship *M V Figaro*, an ORC unit on the container ship *Arnold Mærsk*, and a third unit installed on board the coal carrier *Asahi Maru*. A number of challenges, e.g., the high purchase cost, the flammability and toxicity of the working fluid, and the integration on board, exist before economy of production and standardization can be achieved.

In 1984, Angelino et al. [10] presented a first review on the design, construction, and testing of ORC power systems, from the perspective of the Italian activity. Since then, a number of review works on topics related to the ORC technology have been published. While some reviews provide a general overview of the technology [7,8,11–16], others focus on specific aspects such as the heat source characteristics [17] or the applications [18–22]. Other reviews analyze the details of components design for ORC units, presenting the advances on expanders design [23–28] or the selection criteria of working fluids [28–30].

Regarding the application of ORC units for WHR, Lecompte et al. [31] presented recently a general review. Earlier, Ziviani et al. [32] analyzed the challenges of ORC systems used for low-grade thermal energy recovery. Rahbar et al. [33] presented a review of ORC power systems for small-scale applications, including WHR of internal combustion engines. Tocci et al. [34] also presented a review of small-scale ORC power systems, with a special focus on the specific cost of these systems. Liang et al. [35] and Saidur et al. [36] reviewed different technologies, including ORC power systems, for WHR from exhaust gas heat. The economic and technical feasibility of different power cycles were presented and discussed. The application of ORC units for WHR of

internal combustion engines was expanded by Sprouse and Depcik [37] in their review, which focused on the exhaust gases of vehicle engines. Concerning the WHR from diesel engines, Wang et al. [38] presented a survey on the use of SRC and ORC power systems. The main topics were the effect of the expander performance on the plant efficiency and the selection of the working fluid. Shu et al. [39] and Singh and Pedersen [40] reviewed different WHR technologies for two-stroke marine diesel engines. In the review by Shu et al. [39] ORC power systems were suggested as promising technologies for WHR on ships. Moreover, Bouman et al. [41] reviewed the state-of-the-art technologies for reducing the greenhouse gases emissions from shipping, including a review of WHRS for power and propulsion. Pili et al. [42] presented a study evaluating the economic feasibility of integrating ORC power systems in different transportation sectors, including maritime transport. The authors concluded that the low weight ratio of ORC units to ships payload, and the high share of fuel costs of the total cost of shipping, result in a very profitable use of ORC power systems.

In the above-mentioned works, there is no comprehensive review of the use of ORC power systems for maritime applications addressing the design and operational features of ORC units relevant for this particular application. A survey is lacking on the actual potential of this technology, based on the availability of heat sources on the shipping fleet worldwide. Furthermore, no previous study has addressed the challenges nor provided directions for future research for the integration of ORC power systems in marine applications. This paper aims at determining the most relevant vessel types and heat sources for the implementation of the ORC technology on large ships. The analysis presented here is not only based on published scientific literature, but is also supported by a detailed analysis of data for the design and operational profiles of existing ships. Guidelines on the integration on board, cycle layout, and the working fluid and components selection are given considering environmental, technical, and economic criteria. Challenges and limitations are outlined accounting for operational and technical constraints. The fuel-saving potential of the implementation of ORC power systems aboard is estimated for different ship types. The ORC technology is compared with other available WHRSs, e.g., the SRC unit and the Kalina cycle (KC) plant, and future R&D areas are identified. Data for the review were retrieved from open literature, private communications with ship owners and an engine manufacturer, and the Clarksons Research World Fleet Register [43].

First, the paper introduces (Section 2) the current legislation regulating the emissions in the marine sector. Section 3 ranks the ship types by number of units, main engine power, and  $\text{CO}_2$  emissions. Here, the available heat sources are screened and the WHR potential is quantified. Section 4 is dedicated to the design of the ORC unit and its integration on board. Section 5 describes other alternative WHR technologies. Limitations, challenges and possible R&D areas are outlined in Section 6. Concluding remarks are given in Section 7.

## 2. Legislation

Most merchant ships operate across country borders and in international waters. Therefore, the IMO issues regulations on ship emissions under the umbrella of the United Nations. Until now, the IMO has set limits on  $\text{CO}_2$ ,  $\text{NO}_x$  and fuel sulfur content, the latter being related to  $\text{SO}_x$  emissions and, to some extent, particle emissions.

The first binding agreement on emissions since the Kyoto Protocol, was the establishment of the energy efficiency design index (EEDI) for ships [44]. The EEDI is the ratio of  $\text{CO}_2$  emissions associated with the main and auxiliary engines of a ship to the product of its capacity and speed, expressed in grams of  $\text{CO}_2$  per tonne nautical mile ( $\text{g t}^{-1} \text{M}^{-1}$ ). The method for calculating the index accounts for factors such as the type of fuel, machinery system layout, and the use of green technologies, e.g., renewable energy sources [45]. The reference EEDI is a line relating the average energy efficiency versus the deadweight of ships built between 2000 and 2010. Based on this reference, the required

EEDI values are lowered every five years. The regulatory scheme entailed a 10% reduction of the minimum EEDI value in 2015, and a 30% decrease by 2030, with respect to the reference EEDI.

In order to regulate  $\text{SO}_x$  emissions, the IMO committee also established the so-called emission control areas (ECAs). Inside the ECAs, the maximum allowable sulfur content of the fuel was reduced from 1.5% to 0.1% in 2015. Globally, the limit decreased from 4.5% to 3.5% in 2012. A global limit of 0.5% will be established after 2020 [46]. Scrubber technologies and the use of fuels with low-sulfur content, e.g., low-sulfur marine diesel oil (MDO) or marine gas oil (MGO), biofuels, dimethyl ether (DME), methanol, and liquefied natural gas (LNG) (see Section 4.7), are arguably the most viable solutions to respect these limits.

As for the  $\text{NO}_x$  emissions, the higher the combustion pressure and temperature in the cylinders, the higher the engine performance and  $\text{NO}_x$  emissions. In this regard, the IMO has gradually established rules to prevent air pollution due to the shipping activity. Before the IMO regulations were put into force, the main propulsion engines were often tuned so as to minimize the fuel consumption, thus leading to high  $\text{NO}_x$  emissions. Currently there are three IMO emission standards that set increasingly restrictive  $\text{NO}_x$  emission limits as a function of the maximum operating speed of the engine, and the year of construction of the ship [47]: Tier I (2000) and Tier II (2011), which are global, and Tier III (2016), which is only applicable in  $\text{NO}_x$  ECAs. For ships constructed on or after 1st January 2016, the main engine must emit only 20% of the Tier I limit ( $17 \text{ g kWh}^{-1}$ ) within the ECAs. For ships constructed on or after 1st January 2011, the global limit is currently  $14.4 \text{ g kWh}^{-1}$ , according to Tier II.

Within this regulatory scheme, the installation of WHRSs is a viable measure to increase the overall energy conversion efficiency and reduce emissions, since less fuel will be required to produce the same amount of power (lower EEDIs). It is important to emphasize that the regulations on  $\text{NO}_x$  emissions relate only to the main engine (propulsion) and not to the auxiliary engines (power generation). Because of this, the main engine may be tuned to minimize  $\text{NO}_x$  emissions, and the WHRSs installed on the propulsion side will need to be optimized as integral parts of the propulsion system [48]. Although the implementation of WHRSs does not have a direct impact on the fuel sulfur content, using alternative fuels alters the temperature and mass flow rates of the available heat sources. Moreover, the operating costs related to low-sulfur fuels can be lowered, thus facilitating the transition to these fuels.

### 3. Waste heat recovery on ships

In this section an analysis of the WHR potential is presented. The vessel types responsible for the highest  $\text{CO}_2$  emissions are first identified. Secondly, the general features of a typical marine propulsion system are outlined. An energy analysis of three selected operating ships is then presented to quantify the waste heat and the energy recoverable using the ORC technology. Finally, important remarks and conclusions from the energy analysis are reported.

#### 3.1. Mapping of the world fleet

The total world fleet comprised 107,749 operative units in 2012 according to data tracked by the automatic identification system (AIS) and reported in the third IMO greenhouse gases study [3]. Fig. 2 shows the number of units, installed propulsion power, and  $\text{CO}_2$  emissions by ship type in 2012. The values of installed power refer to the main engine only. The  $\text{CO}_2$  emissions were estimated considering the contribution of the auxiliary engines and boilers for heat supply on board. The data were taken from the third IMO greenhouse gases study on ship emissions [3]. Note that the tanker category includes vessels transporting oil, gas, chemicals, and liquids.

Bulk carriers, tankers, general cargo ships, and service vessels constitute around 60% of the total world fleet. About 30% of the

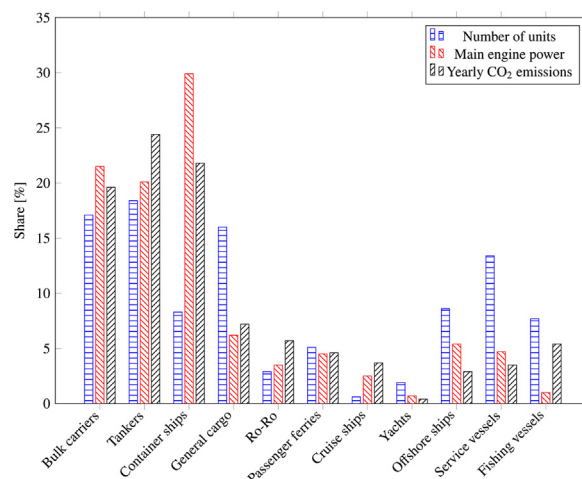

Fig. 2. Number of units, propulsion power and bottom-up  $\text{CO}_2$  emissions by ship type in 2012. The data are taken from the third IMO greenhouse gases study [3].

cumulative power is installed on container ships, although the number of operative units is relatively low (8.3%). On average, these vessels are characterized by high design speeds (21 kn) and deadweights (42,231 t). The average propulsion power installed on board is 27 MW. Bulk carriers and tankers have relatively lower design speeds ( $< 15$  kn) and high average deadweights ( $> 70,000$  t), thus ranking second (21.5%) and third (20.1%), respectively, in terms of installed power.

Fig. 2 shows that container ships, tankers and bulk carriers are responsible for more than 65% of the total yearly  $\text{CO}_2$  emissions. These ships also have the highest utilization factor ( $> 200$  d per year on sail [49]) with mean speeds ranging from 12 to 15 kn. This, in turn, entails high yearly emissions. The share for general cargo, fishing vessels and Ro-Ro ranges between 5% and 7%. These ships are on an average more than 160 d per year at sea and account for around 26.6% of the total world fleet. All other ship types have  $\text{CO}_2$  productions lower than 5%.

The breakdown of the  $\text{CO}_2$  emissions stresses the need for improving the energy conversion efficiency of tankers, bulk carriers, and container vessels, as they share the highest contribution to the total world fleet emissions and have the largest propulsion units. For these ship types, more than 70% of the total emissions relate to the main propulsion engine. Auxiliary engines account for 21.9% and boilers 6.1% of the yearly  $\text{CO}_2$  production [50].

Fig. 3 depicts the number of units and propulsion power supplied by four-stroke and two-stroke diesel engines for bulk carriers, container ships, and tankers. The plot shows that two-stroke low-speed engines dominate the market. In addition to a higher efficiency the advantages compared to the four-stroke counterpart are: (i) a higher power density in  $\text{kW m}^{-3}$ , (ii) direct coupling to the propeller, thus avoiding the losses associated to the use of a gear box, and (iii) the possibility of designing propellers with large diameters, improving the mechanical efficiency [51]. Although four-stroke engines could be initially more interesting from the stand point of WHRS as they have higher exhaust gas temperatures due to their lower efficiency, their smaller sizes make WHRS more feasible on two-stroke engines.

#### 3.2. Machinery system aboard

Fig. 4 depicts a sketch of a state-of-the-art machinery system for large ships. The main engine is equipped with receivers for exhaust and scavange air to accommodate the constant pressure operation of the turbochargers. At loads below 40% or 50%, auxiliary blowers provide the required scavange air flow. Conversely, at high loads, a fraction of the exhaust gas flow can be bypassed and converted into power in a separate turbine, i.e., the power turbine (PT). A SRC plant can be added

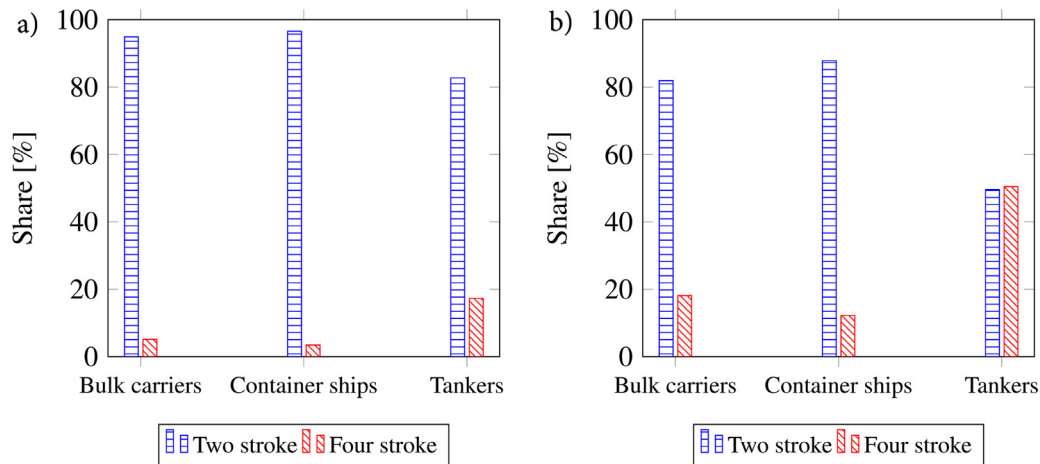

Fig. 3. Engine power and number of ships equipped with four-stroke and two-stroke diesel engines by ship type. Bulk carriers, container ships and tankers are considered: a) Main engine power, b) Number of units. The data are taken from the third IMO greenhouse gases study [3].

to utilize the exhaust gas heat after the turbochargers and the PT for steam evaporation while utilizing the scavenge air and jacket water heat for feed water preheating.

In large ships, the electric load is usually lower than the power that can be recovered from the thermal energy expelled by the main engine. An option improving flexibility and performance is to use a shaft-mounted motor/generator between the main engine and the propeller [51]. In this way, the electricity supplied by the PT or the SRC unit can be converted into mechanical power so as to reduce fuel consumption and emissions.

### 3.3. Energy analyses

What follows next is an evaluation of the yearly available waste heat and the recoverable energy using the ORC technology, for three selected vessels, i.e., a container ship, a bulk carrier, and an oil tanker. The container ship is based on a Mærsk Line vessel, similar to the one

studied in Andreasen et al. [52]. The bulk carrier and oil tanker are based on the ships Nord Neptune and Nord Goodwill, respectively, which are owned by Dampskibsselskabet NORDEN A/S. Only the heat sources available from the main engines were considered, given the relatively low contribution provided by the auxiliary engines. Table 1 lists the approximate sizes of the vessels and the main engine specifications used for estimating the WHR potential.

As shown in Fig. 4, there are four streams which can be exploited for WHR: exhaust gases, jacket water, lubricating oil, and scavenge air. The low temperature of the lubricating oil, around 45 °C, discourages the use of this source for WHR. Therefore, the evaluation of WHR potential only included the utilization of exhaust gases, scavenge air, and jacket water heat. As an example of the share of these waste heat sources, Fig. 5 shows a Sankey diagram of the distribution of power and heat flows, and their temperatures, for the engine MAN 6S80ME-C9.5 at 100% load. Two cases were studied for the exhaust gases: a contemporary scenario where engines using high-sulfur fuels, for example

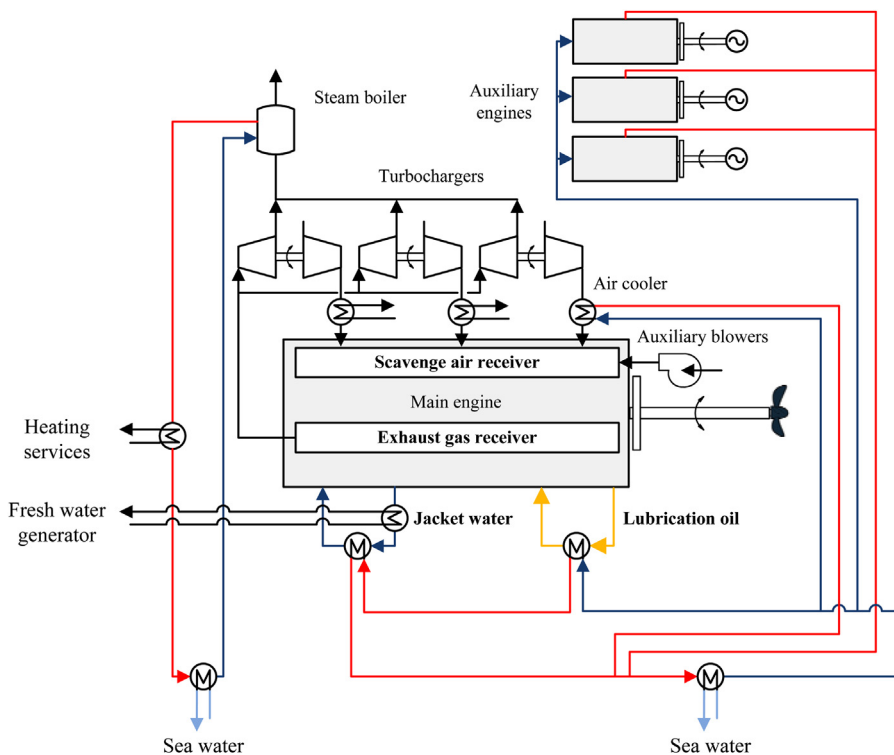

Fig. 4. Simplified layout of a state-of-the-art machinery system aboard large ships. Streams marked in red represent water streams at high temperature, while those marked in blue refer to water streams at low temperature. Yellow lines represent the lubricating oil circuit, and black lines represent the air and exhaust gases flows. The potential heat sources are indicated with bold font.

**Table 1**  
Approximate sizes of the vessels and main engine specifications used in the WHR potential estimations.

Parameter	Container ship	Bulk carrier	Oil tanker
Size	≈ 4500 TEU <sup>a</sup>	≈ 75000 DWT <sup>b</sup>	≈ 50000 DWT <sup>b</sup>
Main engine type	MAN 6S80ME-C9.5	MAN 7S50ME-C8.5	MAN 6S50ME-C8.5 SMC
power [MW]	23	12	10
Speed [rpm]	74	127	127

<sup>a</sup> Twenty Foot Equivalent Unit.

<sup>b</sup> Deadweight tonnage [t].

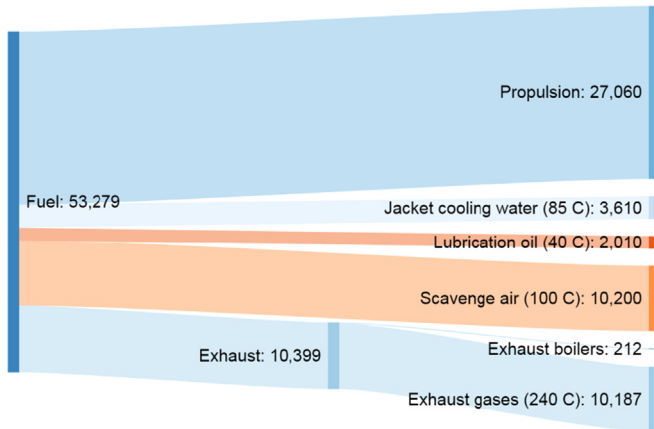

**Fig. 5.** Sankey diagram of the engine MAN 6S80ME-C9 at full load. The heat flows and propulsion power are indicated in kW.

HFO, were considered, and a future scenario where engines using low-sulfur fuels (see Section 4.7) were considered. For these two cases the performance of the ORC units were compared with the performance of state-of-the-art dual-pressure SRC units.

In the high-sulfur fuel case, service steam is generated from the exhaust gases and the boiler feed temperature is at least 148 °C. For the dual-pressure SRC unit, service steam is extracted from the high-pressure steam drum, while for the ORC unit a service steam boiler is located prior to the ORC unit in the exhaust gas channel [52]. The service steam supplies heat for HFO preheating, HFO tank heating and space heating, while the boiler feed temperature constraint serves to keep the coldest spot in the exhaust gas boiler above the sulfuric acid dew point. For the container ship, 1730 kg h<sup>-1</sup> [52] of service steam was produced from the exhaust gases, while a production of 1250 kg h<sup>-1</sup> [53] was assumed for the bulk carrier and the oil tanker. The low-sulfur fuel case represents a maximum utilization scenario where the sulfur content in

**Table 2**  
Energy analysis case overview.

WHR case	Engine fuel and tuning	ORC fluid	$\eta_t$	$\Delta T_{pp,boil}$	Process layout	Control strategy
Exhaust gas, high-sulfur fuel	Heavy fuel oil and LP SCR tuning	MM	ORC: 72% SRC: 62%	20 °C	SRC: Dual pressure [52] ORC: Preheating with jacket water and recuperator [52]	SRC: Constant water level in steam drums and boiler pressure control according to Andreasen et al. [52] ORC: Constant boiler feed temperature, and control of the boiler pressure according to Andreasen et al. [52]
Exhaust gas, low-sulfur fuel	Dual fuel and LP SCR tuning	cis-pentane	ORC: 72% SRC: 62%	20 °C	SRC: Dual pressure [52] ORC: Preheating with jacket water without recuperator	SRC: Constant water level in steam drums and boiler pressure control according to Andreasen et al. [52] ORC: Superheating degree constant
Scavenge air	Heavy fuel oil Container: LL tuning Bulker: HL tuning Tanker: HL tuning	R245fa	ORC: 90%	20 °C	ORC: Simple layout, see Fig. 1	ORC: Superheating degree constant
Jacket water	Heavy fuel oil Container: LL tuning Bulker: HL tuning Tanker: HL tuning	R245fa	ORC: 90%	5 °C	ORC: Simple layout, see Fig. 1	ORC: Superheating degree constant

Abbreviations and symbols: low load (LL), high load (HL), turbine efficiency ( $\eta_t$ ), boiler pinch point ( $\Delta T_{pp,boil}$ ).

the fuel is so low that sulfuric acid formation is not a problem. In this case, no minimum boiler feed temperature constraint was imposed. The use of low-sulfur fuels, for example LNG in a dual-fuel engine with MDO or MGO as a pilot fuel or LNG in a gas engine, can eliminate the service steam demand for fuel preheating and tank heating. Assuming that space heating demands can be covered from other sources, for example from jacket water, no service steam production is required in the low-sulfur fuel case.

The potential of installing ORC and SRC units for WHR was quantified based on the numerical models presented in Andreasen et al. [52]. First, the nominal performance of the WHR systems was estimated based on a design model for a selected main engine load (design point). Subsequently, an off-design model was used to predict the part-load performance of the ORC unit, across the operational profiles of the vessels, and to estimate the fuel-saving potential. For each WHR unit the design point was selected at either 100%, 75%, or 50% main engine load depending on which gave the highest fuel savings. For the jacket water case, the option of designing the unit at 30% main engine load was also considered. In the cases when the main engines operated at loads higher than the selected design point, the power output of the ORC unit was maintained at the nominal value. The CEAS engine calculation tool [54] was used to estimate the thermal power, the mass flow rate and the temperature of the heat sources.

Table 2 provides an overview of the considered WHR cases. For the exhaust gas cases, a LP SCR (low-pressure selective catalytic reduction) engine tuning was employed in order to enable high exhaust gas temperatures, which is beneficial for WHR. For the scavenge air and jacket water cases, high load or low load tunings were selected depending on whether the ships operated more often at high or low engine loads. The ORC working fluids, turbine design efficiencies and boiler pinch points were selected based on Andreasen et al. [52] for the exhaust gas cases and based on Yuksek and Mirmobin [55] for the jacket water case. Different efficiencies are selected for the ORC and SRC unit turbines, since previous works have indicated that higher turbine performance can be achieved with organic fluids compared to steam [56]. The steam turbine efficiency was based on a SRC model validation using experimental data, while the ORC unit turbine efficiency was based on test cases presented in the literature; see Andreasen et al. [52] for more details. The fluid and turbine efficiency of the scavenge air case was assumed to be the same as the jacket water case. The boiler pinch point for the scavenge air case was assumed equal to that of the exhaust gas cases, since the heat transfer properties of gas and air are similar. The remaining modeling conditions used in the simulations were equal to the values used in Andreasen et al. [52].

### 3.3.1. Operational profiles

The operational profiles used in the energy analyses have a major impact on the results as they determine the temperature and flow of

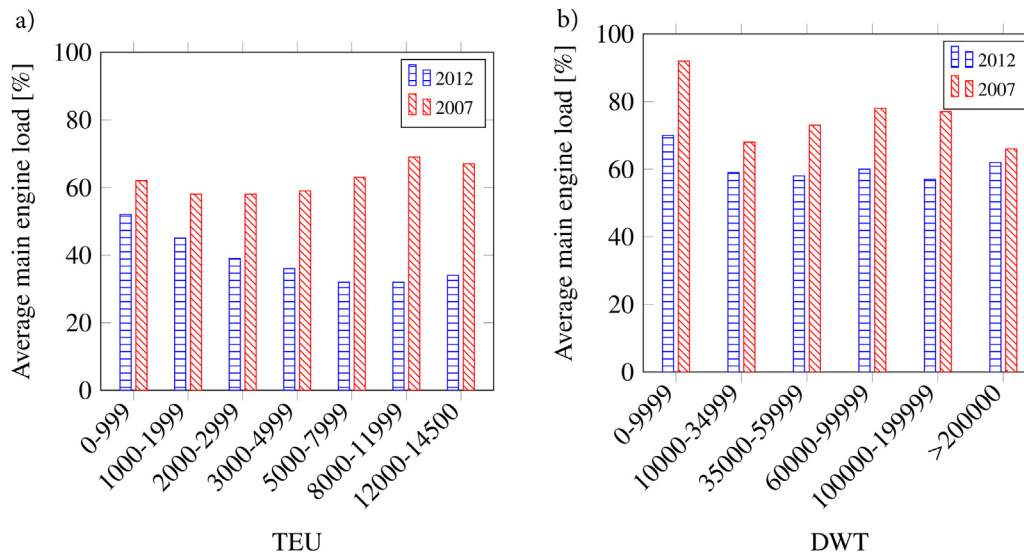

Fig. 6. Average at-sea main engine load factor in 2007 and 2012 as a function of the size category, which is given in Twenty Foot Equivalent Unit (TEU) for container ships (a), and in Deadweight tonnage (DWT) for bulk carriers (b).

each of the available heat sources, and therefore, the economic viability of the WHRS [57]. The container ship was assumed to sail with a load profile typical of slow steaming practice. Higher average power capacities are common for bulk carriers (moderate slow steaming) and oil tankers (average speed close to the design point). Ship owners endeavor slow steaming activities in periods of increasing fuel prices, declining freight rates and high overcapacity [35]. These factors occurred simultaneously during 2007 and 2008, and led to operation at reduced speeds and to the design of new-buildings with smaller engines [35].

Fig. 6 shows the average load factor of the main engine during voyage for the container and the bulk carrier fleet in 2007 and 2012, as a function of the vessel size. As customary, the vessel size is expressed in twenty foot equivalent unit (TEU) for container ships, and in deadweight tonnage (DWT) for bulk carriers. The data are retrieved from the third IMO greenhouse gases study on ship emissions [3]. The container ships sailed in both years at lower mean power capacities compared to bulk carriers and oil tankers (not shown in the plots). This tendency is due to the comparatively high overcapacity of the container shipping segment. All ship types experienced a decrease of average speed. Such a trend is more pronounced for container ships whose mean load factor decreased by 40% in five years. Bulk carriers and oil tankers experienced a more moderate reduction of mean power capacity, i.e., 18.8% and 26.0%, respectively.

### 3.3.2. Container ship

The container ship was assumed to operate at low speed corresponding to typical slow steaming operation with 30% main engine power being the most frequent load of the engine ( $\approx 1000 \text{ h yr}^{-1}$ ). Fig. 7 shows the energy recovered with the ORC and SRC technologies and the net power production. The values are given as a function of the engine load accounting for the yearly operational profile of the ship.

The WHRSs exploiting the low-sulfur exhaust gas heat yields the highest yearly electricity production (ORC: 2.70 GW h and SRC: 2.13 GW h), while the electricity production from the high-sulfur exhaust gases is second highest (ORC: 1.08 GW h and SRC: 1.04 GW h). The utilization of the high-sulfur exhaust gas is hindered due to the heating of service steam and the minimum required boiler feed temperature. The WHR units recovering low-sulfur exhaust gas heat produce significantly more electrical power since these constraints are not applicable. The electricity produced by the ORC units from the scavenge air and jacket water are 0.20 GW h and 0.47 GW h, respectively. Although a large amount of energy is available from the scavenge air,

this case represents the lowest potential for WHR. The heat available in the air cooler decreases rapidly with the engine load compared to that of the jacket water, where the temperature and mass flow rate are kept constant during operation. This implies lower off-design efficiencies when using the scavenge air heat.

The electricity produced by the ORC unit is supplied to the grid on board the ship, where it is distributed to various electricity consumers by the power management system. In some situations, the electrical power of the WHR units utilizing exhaust gases can be higher than the electricity demand on the ship. If this is the case, it can be beneficial to install a shaft motor such that the remaining electricity can be used for propulsion. When covering the on board electricity demands, the power from the WHR unit replaces that of the four-stroke auxiliary diesel engines which operate at lower efficiencies than the main engine. The fuel-saving potential of installing WHR units to recover exhaust heat was estimated by considering the following two extreme cases: (1) all the produced electricity replaces the electricity production from four-stroke auxiliary engines with an average fuel consumption of  $210 \text{ g kWh}^{-1}$ , and (2) all the produced electricity is used for propulsion via a shaft motor. The fuel savings were calculated as the fraction of fuel energy saved by the WHR units compared to the fuel energy used in the main engine. The fractions were calculated by considering only the operation between 25% and 100% main engine load, since the engine data was only available in this load range. In the first case the saved fuel was 7.8% and in the second case it was 5.9%, when considering the ORC unit utilizing low-sulfur exhaust gas. The design of this ORC unit is characterized by a volume flow rate ratio of  $23 \text{ kg s}^{-1}$  and an enthalpy difference of  $119 \text{ kJ kg}^{-1}$  across the turbine. The low enthalpy difference enables turbine designs with moderate peripheral speeds and centrifugal stresses, while the low volume flow rate ratio enables turbine stages with low Mach numbers and small rotor blade height variation [58]. Compared to steam turbines, these features enable economically attractive and efficient turbine designs employing few stages [56,58]. This indicates that it is economically realistic to reach high turbine efficiencies for the cyclopentane ORC unit, and that the turbine efficiency of 72% is a conservative value. In case the turbine efficiency of the cyclopentane turbine was 90%, the fuel savings reached for the ORC unit would be 10.0% when the produced electricity replaces production from the four-stroke auxiliary engines.

### 3.3.3. Bulk carrier

Fig. 8 shows the results of the energy analysis. Compared to the

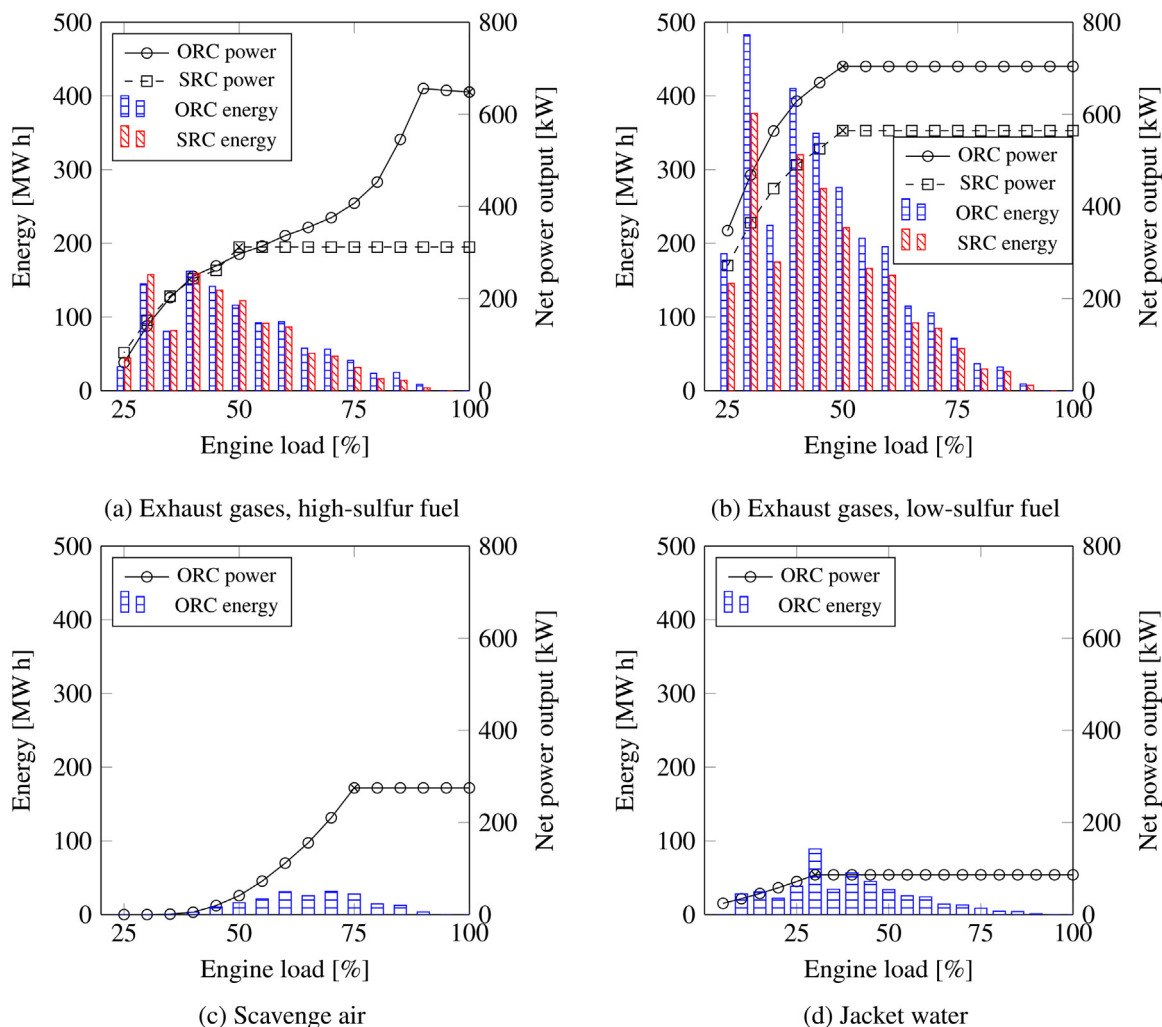

Fig. 7. Annual electricity production (left axis) and net electrical power (right axis) from the WHR units for the container ship with indication of design points ( $\times$ ).

container vessel, the main engine operates at higher average loads (more than 2300 h at around 50%). In 2015 the engine load was kept above 30% at all times, and the normal operating range was, therefore, in the range between 40% and 60% of the main engine load. A high amount of electricity can be produced from the low-sulfur exhaust gases (ORC: 2.39 GW h and SRC: 1.92 GW h). However, for the high-sulfur exhaust gases it is not possible to find an ORC unit solution which respects the boiler feed temperature constraint. This is due to the low amount of energy available after production of service steam. The use of scavenge air for the working fluid preheating prior to the exhaust gas boiler could enable ORC unit operation for this case. Again the highest fuel savings are obtained with the ORC unit utilizing the low-sulfur exhaust gases. Fuel savings of 7.6% are reached when all electricity is used aboard the ship. In the case where the turbine efficiency is 90% the fuel savings reach 9.7%.

The electricity produced from the scavenge air (0.34 GW h) is similar to that of the jacket water (0.35 GW h) for the bulk carrier. Operating the engine at higher average loads compared to the container vessel, increases the energy recovered by the ORC unit exploiting the scavenge air heat.

### 3.3.4. Oil tanker

In 2015, the oil tanker operated at fairly high loads (70% – 80%). The demand for propulsion power was always higher than 40%, thus implying a relatively larger amount of waste heat available compared to the two previous vessels. Fig. 9 shows that the recovered heat from the

scavenge air increases substantially. Again, the ORC unit utilizing the low-sulfur exhaust gases produces a large amount of electricity (ORC: 2.36 GW h and SRC: 2.07 GW h). The corresponding fuel savings are 6.5% for the ORC when the electricity is used aboard the ship. For a turbine efficiency of 90%, the fuel savings reach 8.4%. As for the bulk carrier, it is not possible to find a feasible ORC unit solution which complies with the boiler feed temperature constraint in the case of high-sulfur exhaust gas utilization. When operating at high speeds, the heat in the scavenge air becomes a valuable source. The total electricity produced from the scavenge air using the ORC technology is 0.75 GW h, while 0.35 GW h is produced from the jacket water.

### 3.4. Key points from the energy analyses

The results of the energy analyses entail the following remarks:

1. The exhaust gas heat is an extremely promising energy source for the ORC technology in the cases with engines using low-sulfur fuel. When combined with preheating with the jacket water heat, the ORC unit can convert the exhaust gas heat at relatively high thermal efficiencies, leading to yearly fuel savings up to 10%. The estimations of recoverable energy with ORC units provided in this section are made using a simple design methodology, where the WHRSs are optimized based on the design point and using predefined engine tunings. By using the advanced design methodologies developed by Larsen et al. [59] and Baldi et al. [60], considering combined

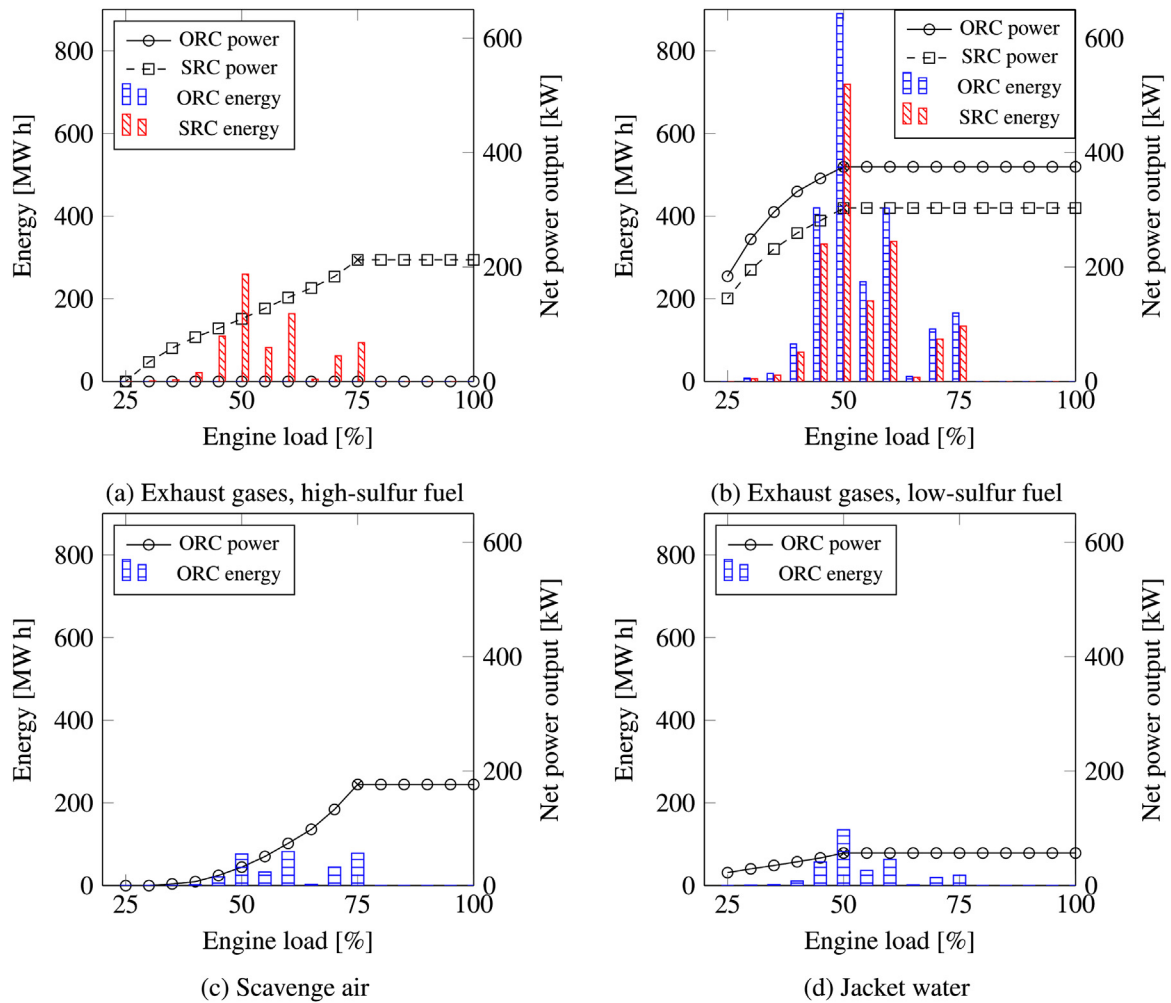

Fig. 8. Annual electricity production (left axis) and net electrical power (right axis) from the WHR units for the bulk carrier with indication of design points (×).

optimization of engine tuning and WHRS design [59] and optimization of the WHRS based on the operational profile of the ship [57], it is possible to enhance the recovery potential of WHRSs. With such design methodologies, it is estimated that the yearly fuel savings could be 10–15% in cases where the electricity is used on board the ship.

2. Retrofitting ORC units for recovery of exhaust gas heat from HFO (high-sulfur) fueled engines is challenging due to the heat demand for service steam and the requirements of high boiler feed temperatures. The technical feasibility of recovering exhaust gas heat increases with the size of the ship, since the fraction of the waste heat used for service steam decreases with engine size. As discussed in Andreasen et al. [52], the use of scavenge air preheating, turbine extraction, or novel fluids with very dry characteristics can possibly enable the ORC unit to reach the required boiler feed temperature.
3. In comparison to the state-of-the-art dual-pressure SRC unit, the ORC unit showed superior performance for the low-sulfur fuel case. In the high-sulfur fuel case for the container ship, the ORC and SRC units recovered similar amounts of energy. It is important to note that the nominal power outputs of the SRC units simulated in the energy analyses are below 600 kW. Dual-pressure SRC units in this power size are rarely seen. For this power range, the ORC unit is the preferred technology [7], which is also expressed in the results of the energy analysis.
4. The scavenge air heat is the greatest waste heat source, in terms of available waste energy. However, the amount of heat and the temperature at which it is available strongly relates to the engine load,

which results in low availability of heat if the vessel adopts a slow-steaming strategy. As a consequence, the heat can only be converted at a modest thermal efficiency by using an ORC unit. The use of the scavenge air heat is more attractive for bulk carriers and tankers sailing at higher average loads than container ships do. On the other hand, slow-steaming practices may be abandoned in the future due to the increase of freight rates, low fuel prices, and the use of engines of smaller size. In this scenario, recuperating the heat in the scavenge air could become crucial to abate the fuel consumption and emissions.

5. The heat in the jacket water is less dependent on the engine load. For low main engine loads, it is therefore possible to recover more energy from the jacket water than from the scavenge air.

#### 4. Design and control of ORC power systems

This section presents a review of the works related to ORC power systems for maritime applications; a summary is provided in Table 3. The purpose is to identify the most suitable cycle architecture, working fluid and equipment (turbine, heat exchangers and pumps) depending on the heat source. In this part, the economic feasibility of the ORC technology and the integration on board are also assessed. Finally, the commercial products available on the market are reviewed.

##### 4.1. Cycle architecture

Organic Rankine cycle power systems can have different cycle

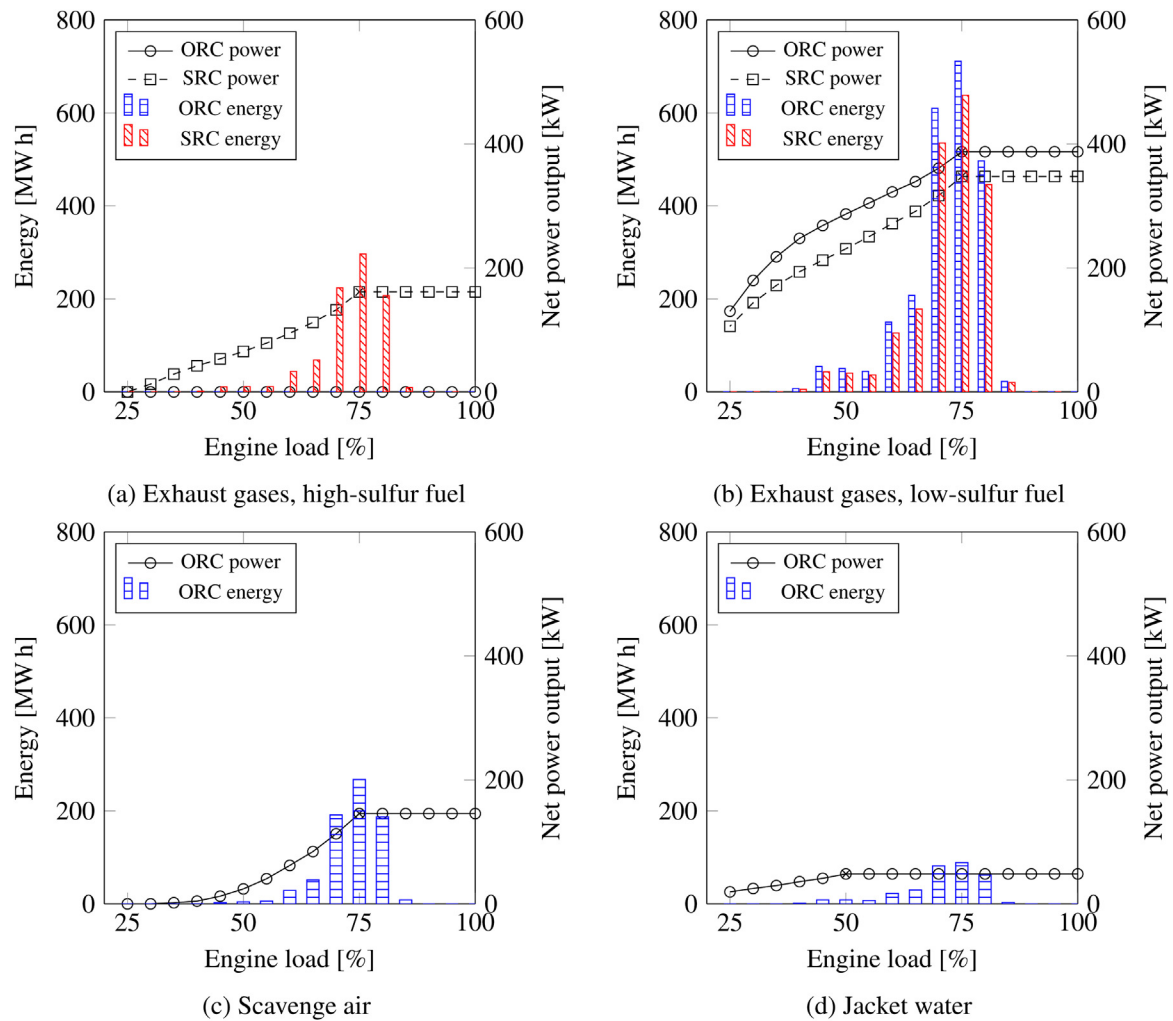

Fig. 9. Annual electricity production (left axis) and net electrical power (right axis) from the WHR units for the oil tanker with indication of design points ( $\times$ ).

architectures, i.e., simple, regenerated, multi-pressure levels, and cascaded. The most common configurations are simple and regenerated cycles (see Fig. 10). Cascaded ORC units are, by now, only installed in large geothermal plants [61].

For waste heat recovery applications, the power output of the ORC unit is governed by the amount of heat extracted from the heat source and the thermal efficiency of the Rankine cycle. In the case that the minimum heat source temperature is restricted, the highest power output is achieved for the system with the highest thermal efficiency of the Rankine cycle. Hence, the regenerated ORC unit (Fig. 10a) is the most suitable cycle architecture to recover the exhaust gas heat in the case that the minimum temperature in the boiler is restricted due to sulfur contents in the fuel, as regeneration improves the conversion efficiency. Yang and Yeh [62] estimated that this layout can boost the power output by 10% compared to the simple configuration for a generic cargo ship. The same authors [63] confirmed this result later on, in their thermo-economic optimization of two ORC units, with and without regeneration, using the exhaust gas of a marine diesel engine of a merchant ship. Ahlgren et al. [64] found similar figures for a cruise ferry operating in the Baltic Sea. However, Shu et al. [65] did not opt for a regenerated configuration in their thermo-economic analysis of an ORC unit working under the same conditions as in Ref. [64]. An alternative configuration for the recuperation of exhaust gases was also introduced by Yang [66], who presented an evaluation of a transcritical organic cycle using working fluids with zero ozone depletion potential (ODP) to recover the waste heat from the exhaust gas, cylinder cooling

water, scavenge air cooling water and the lubricating oil of a large marine engine.

As for the regenerated ORC unit, several authors [67–70] proposed the use of an intermediate oil loop to transfer the high temperature heat to the organic fluid. Introducing this equipment in the layout has two major benefits: (i) it minimizes the risk of degradation of the fluid during start-up and shut-down, and (ii) it eases the controllability of the unit by dampening temperature and mass flow rate variations of the heat source [8]. Moreover, an intermediate loop allows collecting the heat from multiple sources, e.g., the exhaust gases of main and auxiliary engines [68]. However, this solution increases the system complexity and penalizes the thermal efficiency of the ORC unit due to the increased heat transfer irreversibility. The same drawbacks arise if an intermediate loop filled by fresh-water is used between the ORC condenser and the seawater-cooled heat exchanger (HEX5); see Fig. 10a. Nevertheless, Ahlgren et al. [64] claimed that the use of an intermediate loop on the condenser side enables minimizing the piping and equipment exposure to corrosion. Depending on the length of the circuitry and the components' size, using corrosion-resistant materials, e.g., copper-nickel alloys, titanium, or plastics [71], enables avoiding the use of such intermediate loop. An alternative solution would be to use air as the cooling fluid for the unit, as proposed by Suarez de la Fuente et al. [72]. This configuration was suggested for the Arctic region, where the air temperature is always below that of the seawater, but the authors concluded that even in this circumstance seawater was the preferred cooling fluid.

**Table 3**

Summary research works on the use of the organic Rankine cycle technology on board ships. EG: exhaust gas; JCW: jacket cooling water; SA: scavenge air; ORC: simple ORC configuration; rORC: regenerated ORC; dpORC: double pressure ORC; tORC: transcritical ORC; cORC: cascade ORC.

Author(s)	Ship type	Heat source	Cycle architecture	Optimal working fluids
Yusek and Mirmobin [55]	marine diesel engine	JCW	ORC	R245fa
Larsen et al. [59]	marine diesel engine	EG	rORC	cyclopentane, MM, benzene
Yang and Yeh [62]	Merchant ship	EG	ORC	R1234ze, R245fa
Yang and Yeh [63]	Merchant ship	EG	ORC, rORC	R1234ze, R245fa
Ahlgren et al. [64]	Cruise ferry	EG	ORC, rORC	toluene, benzene
Shu et al. [65]	Cruise ferry	EG	ORC	R123, R365mfc
Yang [66]	marine diesel engine	EG	tORC	R152a, R1234yf
Larsen et al. [67]	marine diesel engine	EG	ORC, rORC	cis-hexane, toluene
Bellolio et al. [68]	marine diesel engine	EG	ORC	R245fa
Suarez de la Fuente and Greig [69,89]	marine diesel engine	EG	rORC	benzene
Suarez de la Fuente and Greig [72]	Container ship	SA	ORC	R1233zd(E)
Choi and Kim [73]	Container ship	EG	TC, ORC	water, R1234yf
Nielsen et al. [74]	marine diesel engine	EG, SA	SRC, ORC	water, R245fa
Deniz [75]	marine diesel engine	EG	SRC, ORC	R601a
Song et al. [76]	marine diesel engine	JCW	ORC	R141b, R245fa
Faisal et al. [77]	Container ship	JCW	ORC	R134a
Yang and Yeh [78]	marine diesel engine	JCW	rORC	R600a
Andreasen et al. [79]	marine diesel engine	EG, SA, JCW	ORC, rORC	toluene, cyclopentane, R32
Lode [80]	marine diesel engine	Eg, SA	ORC, rORC	R114
Grlijusic et al. [81]	suezmax oil tanker	EG, SA, JCW	ORC	R245fa, R123
Larsen et al. [82]	marine diesel engine	EG, JCW	rORC	–
Koroglu and Sogut [83]	marine diesel engine	EG, JCW	rORC	R113
Hountalas et al. [84]	marine diesel engine	EG, SA	SRC, rORC	water, R245ca
Soffiato et al. [85]	LNG carrier	FWG, SA, JCW, LO	ORC, rORC, dpORC	R227ea, R236fa, R245ca
Kalikatzarakis and Frangopoulos [86]	marine diesel engine	EG, SA, JCW	ORC, rORC, cORC	R245fa, R413a
Mondejar et al. [87]	Cruise ferry	EG	rORC	benzene
Girgin and Ezgi [88]	naval surface vessel	EG	rORC	benzene

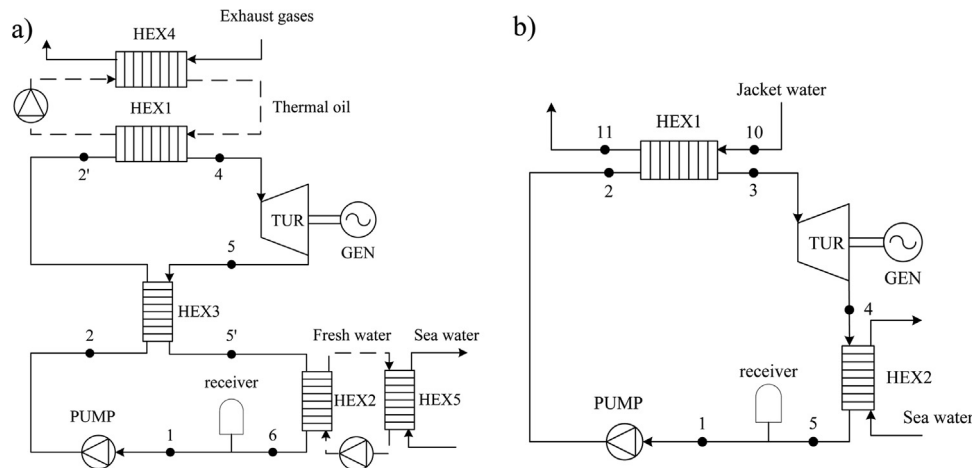

**Fig. 10.** The layout of the ORC units harvesting the heat from the exhaust gases and jacket water. a) Regenerated ORC fed by the exhaust gases. HEX: heat exchanger; TUR: turbine; GEN: generator; PUMP: pump.

The exhaust gas heat can also be recovered by integrating SRC and ORC power systems. Choi and Kim [73] studied a WHRS for the exhaust gases of a marine engine employing an integrated water trilateral cycle and ORC unit. Nielsen et al. [74] proposed to combine an ORC unit with a power system comprising: i) a device for the removal of sulfur oxides, and ii) a SRC unit using the exhaust gases and scavenge air heat. Similarly, Deniz [75] showed that adding an ORC unit to the existing SRC plant can reduce further (2%) the fuel consumption.

Both simple and regenerated ORC power systems have been proposed to exploit the jacket water heat. Song et al. [76] used a simple layout to harvest the heat from the cooling system of a six-cylinder turbocharged marine engine. Faisal et al. [77] studied an ORC unit using R134a to recover the waste heat of the jacket cooling water of an engine in a container ship. Yang and Yeh [78] studied a regenerated ORC module recuperating the heat from the jacket water of large marine diesel engines. For the same application, Andreasen et al. [79]

optimized the simple configuration using two different design methods. Yuksek and Mirmobin [55] presented a commercial ORC turbogenerator, developed by Calnetix Technologies, to recover the jacket water heat of large vessels. Their ORC module had a simple layout (see Fig. 10b) and can be cooled using seawater without the use of an intermediate loop.

As for the integration among the different heat sources, a number of studies [80–82] investigated the performance of simple ORC units collecting the heat from the exhaust gases, scavenge air and jacket water, simultaneously. In these cases the working fluid is first preheated using the jacket water and scavenge air heat. Subsequently, evaporation takes place exploiting the exhaust gas energy. This case involves the study by Koroglu and Sogut [83], where an exergy analysis was performed on an ORC unit for WHR of a marine engine where the exhaust gases were used to evaporate and superheat the working fluid, which was partially preheated by the jacket cooling water. The layout

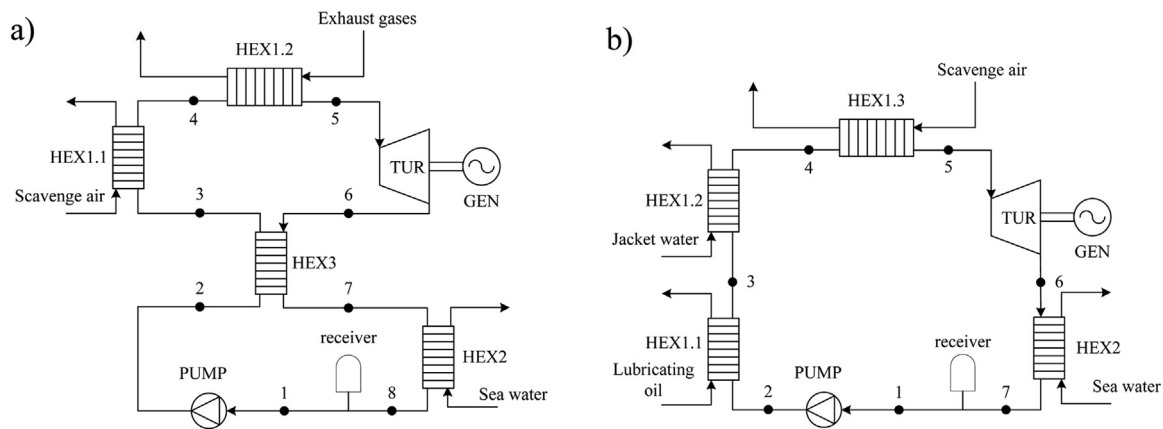

Fig. 11. Possible integration of the different heat sources available on board using the ORC technology. a) Regenerated ORC fed by the heat in the exhaust gases and scavenge air, b) simple ORC fed by the heat in the lubricating oil, jacket water and scavenge air. HEX: heat exchanger; TUR: turbine; GEN: generator; PUMP: pump.

proposed by Larsen et al. [82] includes a recuperator, with the purpose of augmenting the thermal efficiency of the ORC unit. Grljušić et al. [81] proposed the same layout to supply the heating and electricity demand of a Suezmax-size oil tanker. Kawasaki Heavy Industries suggested a double-pressure evaporation to recover the heat of these sources at different temperature levels for a liquid petroleum gas carrier [80]. However, Lode [80] found that a regenerated ORC unit only fed by the exhaust gas heat could achieve even greater power output than the Kawasaki option.

A possible integration, studied by Lode [80] and Hountalas et al. [84], aims at integrating only the exhaust gas and scavenge air; see Fig. 11a. Lode [80] estimated that a 10% increase in power output is possible compared to a regenerated ORC system fed only by the exhaust gas heat. Therefore, exploiting together the exhaust gas and scavenge air heat is the best option to maximize the power output of the regenerated ORC module. Conversely, the jacket water should not be used for preheating since the same function can be performed by the recuperator.

Soffiato et al. [85] analyzed the performance of a simple ORC turbogenerator collecting the heat from the lubricating oil and jacket water only. In particular, they investigated the effect of the recuperator on the plant layout, concluding that such component does not improve the net power output compared to the simple cycle configuration. Moreover, Soffiato et al. [85] found that exploiting the scavenge air heat can boost the power output of the ORC unit by 13%. This can be realized by using the layout shown in Fig. 11b [85,86]. Soffiato et al. [85] and Kalikatzarakis and Frangopoulos [86] also proposed the use of dual-pressure or cascade cycle architectures, claiming increases in the system performance of about 40% and 25%, respectively, though at the expense of a higher system complexity.

Nevertheless, if several heat exchangers are connected in series to integrate the scavenge air with other heat sources (see Figs. 11a and 11b), the off-design characteristics of the ORC module should be examined carefully, as the high variability of the energy of the scavenge air at off-design conditions could lead to long periods of shut-down of the unit. Moreover, it should be noted that the plants shown in Figs. 10 and 11 could operate as supercritical cycles without requiring additional equipment. Despite the significant increase in pumping power, this configuration usually allows enhancing the thermal efficiency of the ORC unit [18]. On the other hand, such systems are still in the development phase and have been tested, by now, only in a few experimental studies [7].

In summary, in order to facilitate short payback periods, which are commonly demanded in the maritime industry, simple cycle architectures are arguably more economically attractive than complex architectures. In this sense, the simple ORC configuration is recommended for WHR of jacket cooling water, while regenerated ORC

units are more suitable for the recovery of exhaust gases. Intermediate loops would be initially inadvisable, since their installation increases the total investment cost and heat transfer losses, unless the advantage of integrating several heat sources is justified by the vessel's operational profile and size, or an intermediate loop is required for safety reasons.

#### 4.2. Working fluids

The selection of the working fluid constitutes a critical step in the design of ORC power systems as it has a direct impact on the cycle efficiency and the component designs. In the following section, a review of the works aimed at finding the best organic compounds for the cycle architectures shown in Figs. 10 and 11 is given. Next, the restrictions applying for the use of some working fluids under the current regulation schedule are highlighted. Finally, based on the results and conclusions from the preceding sections, recommendations for future working fluids for marine applications are made.

##### 4.2.1. Working fluid selection

Regarding the recovery of the exhaust gas heat, Lode [80] suggested, in the early 80's, to adopt six chlorofluorocarbons (CFC), i.e., R11, R12, R22, R502, R113, R114, for a regenerated ORC power system fed by the exhaust gas heat, but all of these fluids are today under consideration for phase-out. More recently Larsen et al. [67] found that dry hydrocarbons (cyclohexane, toluene, benzene) yield the highest energy conversion efficiency. Also, the same authors claimed that R245fa is the optimal fluid candidate to reduce the fire hazard, despite its high global warming potential (GWP). This refrigerant was also proposed by Bellolio et al. [68] to recuperate the exhaust gas heat from marine engines. Considering the thermal efficiency as indicator, Ahlgren et al. [64], Mondejar et al. [87], Girgin and Ezgi [88], and Suárez de la Fuente and Greig [69,89] showed that benzene is the best working fluid to recover the exhaust gas heat. Larsen et al. [59] proved that using cyclopentane, MM or benzene allows obtaining the optimal trade-off between engine  $\text{NO}_x$  emissions and fuel consumption. Yang and Yeh [62] studied R1234ze, R245fa, R600, and R600a leveraging on thermodynamic and economic indicators. The authors found that R1234ze gives the highest net power output, while using R245fa enables minimizing the payback period of the investment. Andreasen et al. [79] found that toluene and benzene give the highest work output while keeping constant the UA-value. Recently, Yang [91] studied the optimization of an ORC unit for WHR of the exhaust gases of a large marine engine and concluded that the use of mixtures as working fluids is an effective way to shorten the payback period of the installation.

As for the studies on the fluid selection for the simple ORC unit fed by jacket water heat (see Fig. 10b), these consider mostly the use of halogenated refrigerants. Yang and Yeh [78] optimized the ratio of net

power output to the total area of the heat transfer equipment for six compounds, i.e., R600a, R1234ze, R1234yf, R245fa, R245ca, and R1233zd. The authors obtained the optimal ratio when using R600a as the working fluid. In Song et al. [76], the optimal compound was chosen among non-ozone depleting substances. The refrigerants R245fa and R236fa resulted as the optimal fluids, despite their high GWP. Considering a fixed UA-value as an indicator of heat exchanger size and cost, Andreasen et al. [79] proved that R245fa gives the highest net power output compared to R134a, R32 and a mixture of the two. The refrigerant R245fa is also used in the simple ORC turbogenerator designed by Calnetix Technologies [55].

For the regenerated ORC unit collecting the heat from the exhaust gases and scavenge air (Fig. 11a), Lode [80] suggested the use of R114 as the working fluid because it was thermally stable at temperatures up to 220 °C. For the same configuration, Hountalas et al. [84] compared an integrated two-stroke diesel engine and Rankine cycle unit running with either steam or R245ca, observing an increase in the net power output of up to 12% when using R245ca.

Soffiato et al. [85] compared the performance of R134a, R125, R236fa, R245ca, R245fa and R227ea as working fluids for a simple ORC turbogenerator collecting the heat from the charge air, lubricating oil and jacket water; see Fig. 11b. They found that R227ea gives the highest net power output. Kalikatzarakis and Frangopoulos [86] screened 11 pure fluids and 9 mixtures to exploit the waste heat from marine engines using the layout and sources shown in Fig. 11b. Using environmental, economic and performance criteria, they found that R245fa and a mixture of R245ca and R365mfc (50/50) are the optimal working fluids. The compound used in the Opcon unit to recover the charge air and jacket water heat is R236fa [25,90].

#### 4.2.2. Legislation

An important aspect related to the selection of the working fluid is the legislation concerning its environmental characteristics. In this regard, the Montreal Protocol [92] governing the phase-out of substances with high ozone depletion potential (ODP), and the regulation on fluorinated gases of the European parliament [93] governing the partial or complete removal of fluorinated substances, need to be considered.

Fig. 12 shows the phasing-out calendar stated in the Montreal Protocol and the regulation on fluorinated gases (the so-called F-gas regulation). The timeline imposes the phase-out of highly ozone depleting substances and restricts the use of substances with high GWP. This applies to a number of working fluids commonly used in ORC systems (e.g., R134a, R236fa, R245fa, R245ca). In accordance with the Montreal Protocol, the revised Marpol Annex VI Regulation 12 [94], which entered into force in 2010, prohibits the use of CFCs in any system on all ships, and considers a transition phase for

hydrochlorofluorocarbons (HCFC) by gradually decreasing their use until their final phase-out by January 2020. Both the Montreal Protocol and the Regulation 12 permit the use of hydrofluorocarbons (HFC), since they are considered as non-ozone-depleting substances. However, these chemical compounds have high or moderate values of GWP. Thus, their use may be regulated in countries following the Kyoto Protocol. As part of the EU commitments in the Kyoto Protocol, new restrictions will limit fluorinated greenhouse gases emissions (and thus the use of HFC) in the EU.

The new F-gas regulation entered into force in January 2015 to strengthen the F-gas regulation enacted in 2006 [93]. This regulation limits the sales of the main F-gases by: (i) banning the use of F-gases in equipment where less harmful alternatives are available, (ii) forcing periodical controls of leakages in the equipment, and (iii) recovering the gases before disposal. The F-gas regulation will have the effect of initiating a phase-out of HFCs, in analogy to the high-ODP fluids regulated by the Montreal Protocol. Furthermore, new maintenance activities will be required to recover the fluid at the end of the equipment lifetime. In 2017, it has become mandatory to equip ORC systems using high GWP fluids with devices for leakage detection. Moreover, it must be noted that although the F-gas regulation applies within the EU, an amendment to extend the F-gas regulation worldwide, under the scope of the Montreal Protocol, was approved on 15th October 2016 by a total of 197 countries. This amendment will be applied differently depending on the level of development of each of the signing countries, and will have a significant impact on the existing ORC power units utilizing HFCs.

The search for fluids with lower GWP could lead to substances with a higher flammability. As reported in Section 4.2, the optimal working fluid is, in most cases, a hydrocarbon. These compounds are flammable, this being a major concern aboard ships. However, no specific regulations about the use of flammable working fluids in marine boilers exist today. In a recent project about the conversion of a ship engine for the use of methanol as fuel, the Technical Research Institute of Sweden (SP) analyzed the measures needed to get fire safety approval according to the rules and regulations of the safety of life at sea (SOLAS) [95]. In this case, regulations 4, 5, 6, 9, 10, 11 and 13 applied. Aspects concerning the probability of ignition, fire growth potential, or fire extinguishing were prescribed. In this sense regulation 17 in Chapter II-2, PART F, provides guidelines on the methodology to follow to seek for alternative design and arrangements. This regulation states that other solutions for fire safety are allowed if they can be shown to be at least as safe as the prescriptive design [96]. The same regulation could be expected, therefore, to be applied for ORC units installed on ships. More specifically, in the Rules and Regulations for the classification of ships by Lloyd's Register [97], fuels are classified into two groups depending on

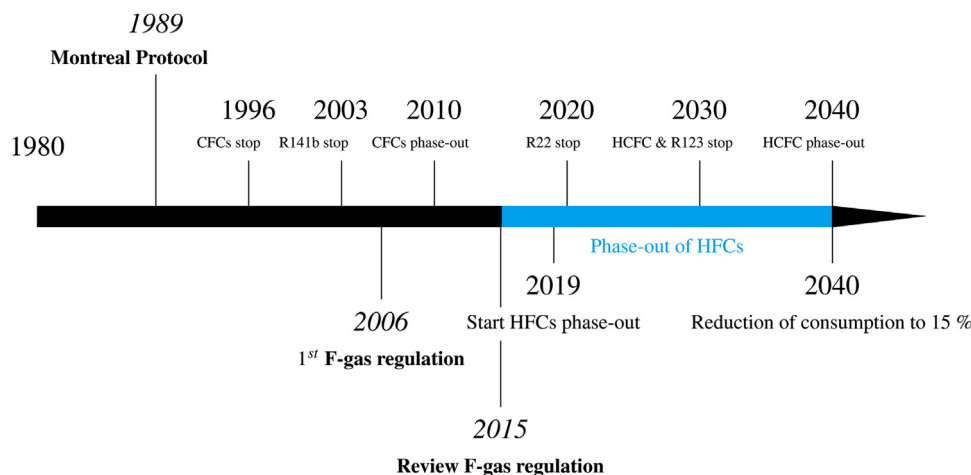

Fig. 12. Phasing-out calendar stated in the Montreal Protocol [92] and the F-gas regulation [93].

whether their flash temperature is below or above 60 °C. Though nothing is specified with regards to the flammable character of refrigerants, it can be inferred that refrigerants with flash temperatures below 60 °C would be considered as potentially more flammable. Examples of working fluids with flash temperatures below that limit are hydrocarbons (e.g. isobutene, cyclopentane), but also some HFC (e.g. R245fa). With regards to refrigeration systems, it is mentioned that refrigerating machinery using toxic and/or flammable refrigerants should be located outside the main machinery space in a separate gastight compartment. This requirement could affect the integration of ORC power systems on board when using flammable working fluids. Moreover, independently of the flammability of the working fluid, it is specified that leak detectors should be installed, and when the amount of working fluid is above 300 kg, monthly tests should be carried out [97].

#### 4.2.3. Working fluids of the future

New working fluids for ORC power systems to be integrated on ships should comply with the aforementioned regulations, provide good performance, and desirably have low or moderate flammability and toxicity risks. These criteria are demanding given that the development of new organic molecules which simultaneously meet thermodynamic, safety, and environmental requirements is limited [98]. In addition, other factors, such as the availability, cost, and influence on the component design must be considered.

The use of hydrofluoroolefins (HFOs) as environmentally-friendly working fluids has recently been suggested by different authors [98,99]. These compounds contain at least one double carbon bond, which is susceptible to degradation in the troposphere and thus reduces the atmospheric lifetime of the molecule. The addition of fluorine provides stability and reduces the flammability of the molecule. The most recent research regarding the use of HFOs focuses on fluoropropenes. Among them, R1233zd, R1234ze(Z), and R1243ye(E) present very low ODP and low GWP. Their critical parameters are close to those of R245ca and R245fa, which were proposed as possible candidates for WHR on board ships. For the same application, Kontomaris [100] recently presented two new working fluids, i.e., DR-2 and DR-40A, developed by DuPont. DR-2 is a hydrofluoroolefin, and DR-40A is a near-azeotropic mixture. Both fluids could likely be used as replacements for R245fa.

The potential of halogenated propenes is limited for medium-temperature energy sources, such as the exhaust gas heat, because of the low critical temperatures of those that are commercially available. However, butene-based or pentane-based HFOs could arise as alternative fluids, as their saturation properties may be closer to those of the hydrocarbons, such as benzene or toluene. Siloxanes, which have no ODP and very low GWP, are well-known options for medium-temperature heat sources. They could be used in the regenerative ORC unit recovering the exhaust gas energy. Suitable siloxanes for this application could be hexamethyldisiloxane (MM) or octamethyltrisiloxane (MDM). However, they present relatively low vapor pressures compared to those of hydrocarbons, thus increasing the risk of air infiltration in the condenser. Additionally, their strong dry behavior entails higher recuperator heat transfer areas. Thereby, further research is needed to evaluate the prospects of using siloxanes on board ships.

In conclusion, the available working fluids that meet all the environmental requirements can be classified into three groups: HFOs (with moderate flammability and high price), hydrocarbons (with high flammability and low price), and siloxanes (with moderate flammability and low price). ORC units used for WHR of exhaust gases and other high temperature sources may use hydrocarbons or siloxanes as working fluids. The choice of the former or the latter would be significantly influenced by the required operational pressures. ORC units recovering the heat from the jacket cooling water may use HFOs, which avoid the risks associated with the high flammability of hydrocarbons, but could increase notably the cost of the installation. Nevertheless, it

should be considered that the use of flammable working fluids may, as well, increase the costs due to extra safety equipment.

#### 4.3. Component design and selection

This section provides guidelines on the most suitable equipment (heat exchangers, pumps and expanders) for ORC power systems on board ships. The analysis focuses on the components and technologies for the ORC units fed by exhaust gas and jacket water heat; see Figs. 10a and 10b.

##### 4.3.1. Heat transfer equipment

The selection of the HEXs is of great importance for the viability of ORC power systems as this equipment represents a significant part of the total capital cost [101] (e.g., according to Lecompte et al. [102] HEXs could represent up to 35% of the total cost of an ORC unit). Furthermore, it usually has the largest influence on the total volume of the installation, which is important as space is a valuable commodity on board ships [103].

In the ORC units shown in Figs. 10a and 11a, the boiler is arguably the most critical component, as it needs to withstand the highest temperature and pressure of the working fluid. In large ships, the exhaust gases are typically available at temperatures above 230 °C and volume flow rates higher than 50000 m<sup>3</sup> h<sup>-1</sup>; see Table 1. Due to the sulfur content of the fuel, corrosion may occur if acids are formed on the exhaust gas side [104]. This should be considered, especially if no intermediate loop is present between the exhaust gases and the ORC evaporator, as the low wall temperature could promote the condensation of the exhaust gases on the tubes. An additional factor to consider is the potential complications derived from the soot deposits on the boiler. This phenomenon has been on the increase in the last decade as a consequence of the lower quality of the heavy fuels used, and the lower exhaust gas temperatures (from about 375 °C to about 245 °C) and velocity of the exhaust gases due to more optimized designs of the engines [105]. Besides a reduction of the efficiency in the heat transfer process, soot deposits can lead to more severe events such as soot fire or iron fire (i.e., the combustion of the boiler itself). These events have been observed more frequently when the exhaust gases flow inside tubes, especially in case of gilled or pinned tubes. In order to avoid this, soot-blowing systems or manual cleaning can be used. Soot deposits can be avoided if the boiler is designed for high gas flow velocities. This, however, entails high pressure drops. In order to ensure efficient operation of the turbochargers the pressure drop across the gas side of the boiler should be below 0.015 bar as recommended by MAN [105]. The requirements of high gas flow velocities and low pressure drops limit the heat transfer surface area of the boiler and thereby the minimum pinch point temperature.

The evaporator of an ORC unit for WHR of the exhaust gases can be a once-through boiler, with the working fluid in the tubes [59], leading to a higher pressure on the working fluid side than in the exhaust gas side. Alternatively, a drum-type boiler can be used. Unlike steam, organic substances have a relatively small difference between the specific volumes in the liquid and vapor phases, which makes it possible to achieve the evaporation of all the working fluid by using once-through boilers [8], therefore avoiding the use of drums [106]. The elimination of the drum allows faster start-ups of the unit, which are commonly constrained by the saturation temperature rise imposed by the thickness of the walls of the drum. In principle, the elimination of the drum minimizes the working fluid inventory [10] and also implies a reduction of the total volume of the installation, but this should be carefully considered as it may also increase the size needed for the boiler, which would need to accommodate all the working fluid volume flow rate.

An exhaust gas heated drum boiler of the finned tube type is commonly employed for steam generation aboard ships [105]. Here, the steam flows inside the tubes and the exhaust gases flow outside, in contact with the fins. A finned tube boiler is also a reasonable option for

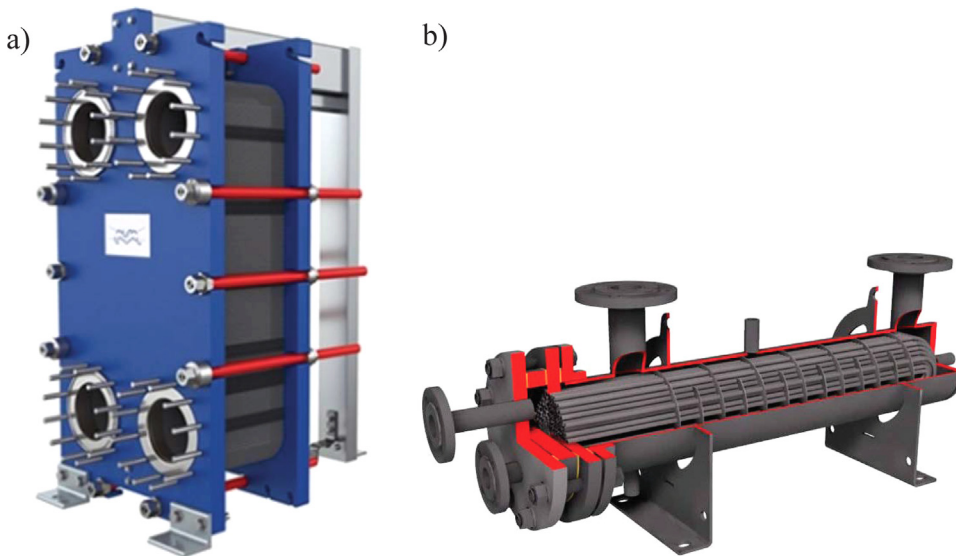

**Fig. 13.** Examples of different types of commercial HEX that could be used for ORC applications on board ships: a) Gasketed plate-and-frame HEX for marine and refrigeration applications. Model T20 Alfa Laval (by courtesy of Alfa Laval), b) a shell and tube HEX for marine applications. Aalborg MX, Alfa Laval (by courtesy of Alfa Laval).

ORC units. This configuration offers high compactness, given the large ratio of heat transfer area-to-volume, but higher approach temperatures (i.e., temperature difference between the hot fluid outlet and the cold fluid inlet) are required compared to, e.g., plate HEXs, since the flow is a combination of co-current, counter-current and cross flow. This, in turn, may decrease the energy conversion efficiency of the ORC unit due to the lower enthalpy drop in the expander.

The use of plate HEXs to recover heat from exhaust gases may be challenging since the volumetric flow rate on each side in plate HEXs is limited to  $2500 \text{ m}^3 \text{ h}^{-1}$  [107]. Moreover, the maximum operating temperature in this type of HEX is around  $250 \text{ }^\circ\text{C}$  [107], although the use of welded plates allows increasing the operating temperature and pressure up to  $500 \text{ }^\circ\text{C}$  and 80 bar. Thereby, plate HEXs could be considered to recuperate the exhaust gas heat on small-size vessels only. An example of a commercial plate HEX can be seen in Fig. 13a.

Lastly, the possibility of using fin-plate or printed-circuit HEXs could be relevant for maritime applications owing to their high heat transfer area-to-volume ratio [108]. The weight of fin-plate and printed-circuit HEXs can be ten times lower compared to that of the shell-and-tube counterpart [109]. This equipment is easily scalable and widely adopted in the oil and gas industry. It can operate at high temperatures ( $800 \text{ }^\circ\text{C}$ ) and pressures (100 MPa), if a diffusion bonding process is used to stack the plates [109]. Their purchased-equipment cost is higher compared to shell-and-tube HEXs. Moreover, cleaning is a crucial aspect to avoid clogging of the channels and to minimize the pressure drops.

The regenerator in an ORC unit typically operates under a large pressure difference between the hot and the cold side. Depending on the working fluid, differential pressures may be up to 4 MPa, and the ratio between the volume flow rates of the two sides may be larger than 100 [61]. As pointed out by Angelino et al. [110], counter-flow configurations are difficult to achieve in ORC regenerators because of the significant difference between the volume flow rates on the sides of the regenerator. Thus, the use of a shell-and-tube HEX (with or without fins) is more common [107]. In this case, it is recommended to locate the cold high-pressure stream inside the tubes, while the superheated vapor passes through the shell. In some cases, the use of a single-tube and multiple-tube helical coil heat exchanger can be suitable to increase further the compactness and minimize the pressure drops on the vapor side [110]. An example of a commercial shell and tube HEX can be seen in Fig. 13b. A low footprint and weight can also be attained by adopting fin-plate HEXs.

For the three vessels analyzed in Section 3.3, the mass flow rate of sea water required by the condenser of the ORC unit fed by the exhaust

gas heat is below  $2500 \text{ m}^3 \text{ h}^{-1}$  (if a temperature increase of 5 K is assumed for the seawater). Thus, both plate and shell-and-tube HEXs are viable. Plate HEXs may be preferable from a performance point of view since approach temperatures as low as  $1 \text{ }^\circ\text{C}$  can be used [107], but this would imply also a larger heat transfer area. If seawater cools the working fluid directly (no intermediate loop), expensive materials should be used to minimize the risk of corrosion in the condenser; see Section 4.1. Alaez et al. [111] proposed to tackle this problem by adopting plastic plate HEXs. They claimed that such equipment enables reducing the cost and weight of the installation, at the expense of increasing the HEX dimensions. The main limitations of plastic HEXs are the maximum allowable pressure (1 MPa) and temperature ( $140 \text{ }^\circ\text{C}$ ) [111]. Also, the direct use of seawater could be a potential source of biofouling, i.e., the accumulation of algae, microorganisms and other marine fauna on the HEX surface. Although there is evidence that this effect could be negligible [112], a periodic monitoring of the condenser to ensure the safe operation of the unit, and the selection of HEX types with easier maintenance (i.e., plate HEX) would be recommended for this case.

In the case of a simple ORC unit fed by the jacket water heat (see Fig. 10b), the temperature lift between the hot source and cold sink is typically below  $70 \text{ }^\circ\text{C}$ , and thus the thermal efficiency of the ORC unit is bound to be low. Plate HEXs are suitable for low approach temperatures, which reduces the performance losses associated with the heat transfer irreversibilities. Therefore plate HEXs are arguably the best heat transfer equipment for the evaporator and condenser in this case. In addition, the use of fin-plate and printed-circuit HEXs should be considered, in order to enhance the system compactness.

In conclusion, while shell and tube HEXs or once-through boilers would be more suitable for ORC units recovering the heat from exhaust gases, the use of plate HEXs, in their simpler or more complex designs (i.e., fin-plate or printed-circuit) would be recommended for applications on jacket cooling water. Moreover, plate HEXs may be recommended as condensers for ORC units on small-size vessels.

#### 4.3.2. Expanders

The selection of the expander type depends on the ORC size/power output, the thermophysical properties of the working fluid, and on the characteristics of the heat source and sink. Expanders can be classified into two categories: positive displacement machines and turbines. Examples of positive displacement expanders are scroll expanders, piston expanders, screw expanders and rotary vane expanders. Turbines can have axial, radial (inflow or outflow), or mixed-flow configurations. Fig. 14 shows images of some of them.

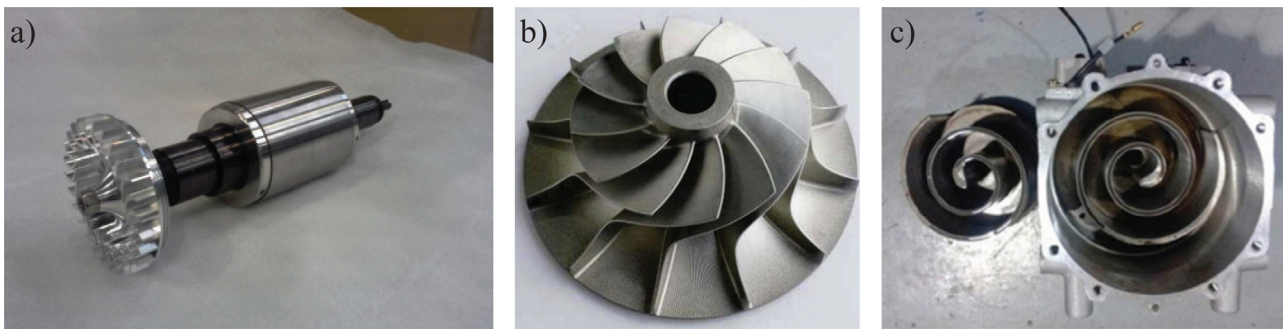

**Fig. 14.** Examples of different types of expanders for ORC applications: a) Rotor of an ORC axial turbine and core of the generator [113], b) rotor of a radial inflow turbine of a 190 kW ORC [114], c) scroll expander rotor and stator of a 1.5 kW ORC unit [115].

Positive displacement expanders are well-suited for low-temperature and low-capacity power systems (1 – 100 kW), where the expansion ratios and the volume flow rates are moderate [7,26,116]. However, their isentropic efficiency is usually lower compared to that of a turbine. On the other hand, the realization of a mini-turbine with a power output in the range of a few or tens of kW is challenging [7]. Thereby, volumetric expanders are often the only alternative at these power capacities.

Conversely, turbines become attractive at power outputs greater than 100 kW and/ or when the temperature of the working fluid is between 120 and 350 °C. In these cases, isentropic efficiencies up to 90% are typically attained [7]. Most ORC turbines are axial or radial machines. Axial turbines perform best at high specific speeds  $\Omega_s = \Omega\sqrt{\dot{V}}/\Delta h^{3/4}$ , i.e., high volumetric flow rates  $\dot{V}$  and low enthalpy drops  $\Delta h$ . Conversely, radial turbines are mainly used when the volumetric flow rate is low compared to the enthalpy difference [117,118]. A reason for this is the greater change in tangential momentum that occurs in radial turbines, meaning that one stage of a radial turbine can elaborate the same specific work as two or more axial turbine stages [119]. This results in radial turbines having less mechanical losses for low capacities, owing to the lower number of rotating discs. Radial turbines are also less sensitive to clearance losses compared to the axial counterpart [120]. Moreover, they are more cost-effective than axial expanders, whose cost increases with the number of stages [121]. However, the size of radial turbines increases more rapidly with the volumetric flow than in the case of axial turbines, making the latter more suitable for high capacities with high enthalpy drops.

For the ships analyzed in Section 3.3, the design point power of the regenerated ORC module fed by the exhaust gas heat can be up to 700 kW. In this power range, both axial and radial configurations can be adopted. If a direct coupling between the turbine and the electric generator is required, an axial expander is preferable since its optimal rotational speed is typically lower than that of its radial counterpart [119]. Hence, there is no need for a gearbox.

The power output of the ORC unit recuperating the heat from the jacket water spans from 50 – 100 kW. Thus, a radial turbine is arguably the most suitable option, especially if the unit is decoupled from the grid by power electronics. In this sense, some ORC systems are equipped with an integrated power module consisting of a radial inflow turbine and an electric generator, in which the high-frequency electric generator can be cooled by the working fluid [122]. Moreover, a screw expander could be also an option if the jacket water is used given the low temperature of this heat source and its capability of handling power capacities up to 1 MW [7,8].

Typically, ORC units considered for recovery of exhaust gas heat would employ an axial flow turbine as the expander due to the large power outputs. In the case of WHR from the jacket cooling water, a radial-flow turbine is also a feasible alternative.

#### 4.3.3. Pumps

In an ORC unit, the pumping power may represent up to 10% of the expander power output [8,123], which makes the selection of the pump of significant importance for the optimization of the cycle. The ratio between the pump power consumption and the turbine power output, i.e., back work ratio, has been found to be related with the inverse of the critical temperature of the fluid [8,123], making it lower for working fluids with higher critical temperature. This can explain the greater impact of the pump work on ORC power systems than on SCR plants, where common working fluids have critical temperatures below that of water used in SRC plants.

Pumps can be grouped as positive displacement pumps (also called volumetric pumps) and centrifugal pumps. Positive displacement pumps (e.g., diaphragm, rotary-vane or plunger pumps) have efficiencies around 40% according to manufacturers' data [8]. Their volumetric flow rate is proportional to the rotational speed, and almost independent of the pressure ratio, which means that their pressure working range is wide and their performance is barely affected by the pressure ratio [124]. However, the volumetric flow in positive displacement pumps is limited by their size. For this reason, volumetric pumps are mainly used in micro-scale and mini-scale ORC systems (< 50 kW). A possible application of these pumps could be ORC systems recuperating the jacket water heat, as in this case the mass flow rate of working fluid is expected to be moderate because the heat available from this source is lower than for exhaust gases. Moreover, the pressure ratio would be lower.

In the case of centrifugal pumps, with efficiencies higher than 60% according to manufacturers' data [8], their volumetric flow rate depends not only on their rotational speed, but also on the pressure ratio. Unlike volumetric pumps, the efficiency of centrifugal pumps is greatly influenced by the pressure ratio, which could be of major concern in case with heat sources with high variability.

Because centrifugal pumps do not have a volumetric limitation, they are usually adopted for higher power capacities. Therefore the use of centrifugal pumps could be more suitable if the exploited heat source is the exhaust gas heat, as greater volume flow rates of working fluids and higher pressure ratios could be expected. Pumps used for this application may require a double seal, with the space between the seals containing circulated refrigerant oil, in order to reduce the possibility of leakages [124].

The standard method to control the operation of an ORC unit is by varying the pump speed, which allows varying the mass flow rate of working fluid. In this regard, the choice of the pump would have a significant impact on the control of the ORC unit. In volumetric machines in part-load, the mass flow rate is imposed and varies in proportion to the rotational speed. Conversely, the head of centrifugal pumps drops monotonically with increasing volume flow rates at constant speed operation. Thereby, the mass flow rate in off-design conditions depends not only on the pump curve, but also on the part-load characteristics of the heat exchangers and the turbine. The control

problem gets more complex due to the non-linear interactions among the components. For example, Mirmobin and Sellers [125] observed pressure and flow instabilities during start-up of ORC units for marine applications. Such operational issue is due to the interaction between the pressure field within the boiler and the pump characteristic curve [125]. Using a volumetric pump allows avoiding these instabilities.

Overall, the use of volumetric pumps would be limited to ORC units operating at low temperatures in small vessels, while centrifugal pumps would be the preferred option for both jacket water and exhaust gas applications.

#### 4.4. Part-load and control

Today, most vessels are running in slow-steaming conditions to minimize fuel consumption. Therefore, WHRSs aboard ships seldom operate at the design point. Controllability and off-design performance are thus of significant importance.

Similarly to SRC plants, ORC systems may operate in sliding-pressure or constant-pressure mode [58,86,126–132]. In the former operational strategy, the turbine control valves are fully opened and the evaporating pressure decreases with decreasing load. Such mode enables the following: i) avoiding throttling losses, ii) decreasing the pump power consumption at off-design, iii) reducing the number of control variables, and iv) maximizing the heat flow extracted from the source. In the constant-pressure mode, the pressure in the evaporator is kept constant at part-load by using partial-arc or full-arc admission, if the expander is a turbine, or a throttle to keep the pressure in the boiler in part-load conditions. The main advantage of the constant-pressure mode is that the storage capacity in the high-pressure section can be exploited for rapid increase of the turbine power [133]. Moreover, a constant pressure allows reducing the thermal stresses in component materials at off-design conditions.

As for the low-pressure side, ORC units usually operate at constant condensing pressure [55,59,87,128,130,131,134,135]. As an example, Horst et al. [134] proposed this operational mode to control an ORC module for WHR from passenger cars. In this case the condensing pressure was kept constant by using an expansion tank which was connected to the ambient by means of a membrane, and the degree of subcooling was controlled by the mass flow rate of the coolant. For maritime applications, the condensing pressure can be adjusted and optimized as the temperature of the seawater varies during operation [126,135].

Fig. 15a shows the layout of the regenerated ORC unit fed by exhaust gas heat including measuring equipment and two valves on the hot and cold circuits. The ORC module has to be operated ensuring the thermal stability of the working fluid. This can be achieved by monitoring the maximum temperature in the ORC unit [126,134,135]. A variable frequency motor and a temperature transducer allow regulating  $T_4$  by varying the speed of the pump. A similar operational strategy is reported in Vetter and Wiemer [126] and Casella et al. [135]. Alternatively, the temperature  $T_{2'}$  of the feed to the boiler can be tracked to prevent sulfur corrosion in the exhaust gas piping. This last control strategy was proposed by Andreasen et al. [52] for an ORC unit recovering the exhaust gas heat of a two-stroke diesel-engine-based machinery system.

In large ships, the ORC unit using the exhaust gas heat can supply enough power to decrease the load of the main engine and shut-down the auxiliaries. In this case, the constant-pressure mode can enhance the dynamic flexibility of the ORC unit as it allows the WHRS to adapt faster to load changes. The three-way valve V1 may be used to bypass the exhaust gases during start-ups and shut-downs or if  $T_{11}$  and  $T_4$  are not within the bounds specified by the operator. The mass flow rate of the coolant can be varied using V2 to control the degree of subcooling and the condensing pressure. Note that the seawater should not be heated above a certain threshold ( $\approx 30\text{ }^\circ\text{C}$ ) to safeguard the operation of the fresh-water generator [55].

Fig. 15b shows the diagram of the simple ORC unit fed by the jacket water heat. The temperature of the heat source is relatively low. Thus, the degree of superheating is typically limited to  $5 - 10\text{ }^\circ\text{C}$  [8], and the risk of fluid decomposition is minimal. The degree of superheating should be carefully monitored to avoid blade erosion and wet losses due to the presence of liquid droplets in the turbine. The speed of the ORC pump can be varied to keep the degree of superheating constant [55,136]. At the same time, the controller should prevent the ORC unit from decreasing the temperature  $T_{11}$  below a minimum value (about  $75\text{ }^\circ\text{C}$ ) to ensure the safe operation of the fresh-water generator [55]. Another reason for controlling the jacket water outlet temperature (or the maximum heat intake of the ORC unit) is to ensure appropriate cooling of the engine cylinders, thus avoiding sulfur corrosion in the cylinders while ensuring optimal lubrication of the cylinder liners. As shown in Table 1, the power output attainable using the jacket water is not sufficient to cover the electricity demand on board. Thus, it is preferable to decouple the ORC generator and the grid by using power electronics [55].

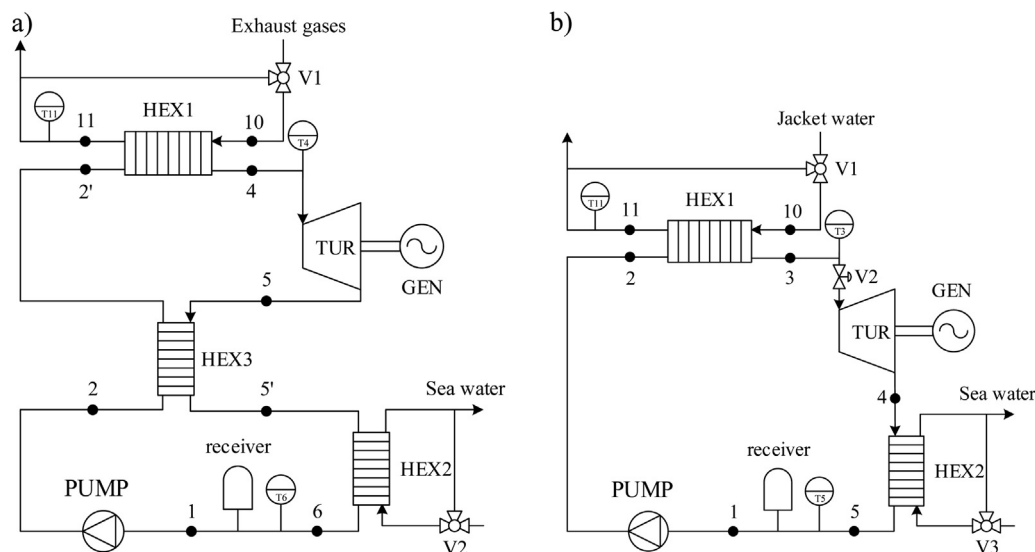

Fig. 15. Layout of the ORC unit including the measuring equipment and control valves: a) Regenerated ORC fed by the exhaust gas heat, b) simple ORC fed by the jacket water heat.

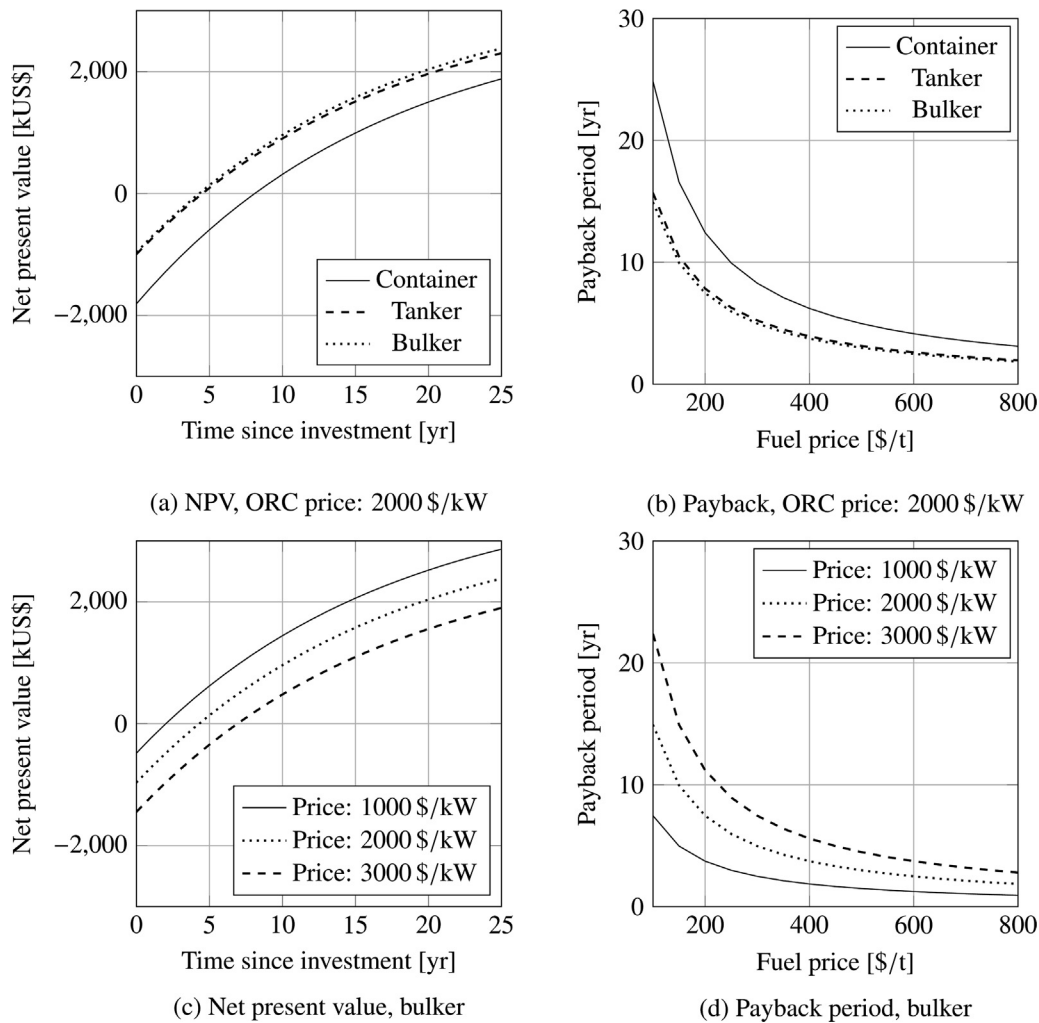

Fig. 16. Results of the economic analysis for the ORC unit fed by the heat from low-sulfur exhaust gases.

4.5. Economic feasibility

The economic feasibility of a marine WHRS depends on the expenses for the installation and operation of the unit and the income related to the fuel savings. The profitability evaluation of installing an ORC unit on the vessels analyzed in Section 3.3 was carried out using the net present value (NPV) method and the simple payback period [137]. The heat sources under consideration were the exhaust gases from the engines using low-sulfur fuel (the case with 90% turbine efficiency) and the jacket water from the HFO engines. For both cases, it was assumed that the power produced by the ORC unit is consumed by demands aboard the ships, which would otherwise be supplied from auxiliary engines operating with an average specific HFO consumption of 210 g kWh<sup>-1</sup>. Reasonable figures for the discount rate and the lifetime of the investment, namely, 6% and 25 years [138], were assumed for the calculation of the NPV.

Fig. 16a shows the NPV of the ORC unit fed by the exhaust gas heat over the years assuming a fuel price of 600 \$/t and a specific ORC unit cost of 2000 \$/kW. The fuel price is representative of HFO prices in the period 2011–2014 [139], while the specific ORC cost is representative of the values reported by Quoilin et al. [8] and Lemmens [140] for ORC units with around 500 – 1000 kW. The final NPV is around 2 MUS\$ for the three ships. The power output of the ORC unit on the container ship is larger than those of the other vessels, and therefore the investment cost is higher. However, due to the low load operation of the vessel, the fuel savings were not correspondingly high. This resulted in a longer

payback period. Fig. 16b shows that the investment is paid back (simple payback period) after 2.5 years for the oil tanker and the bulk carrier and after 4 years for the container ship, when considering a fuel price of 600 \$/t. The payback period drops below 10 years at fuel prices around 150 \$/t for the bulk carrier and the oil tanker and around 250 \$/t for the container ship. Figs. 16c and 16d illustrate the sensitivity of the NPV and the payback period to the specific cost of the ORC unit for the bulk carrier. The payback period is very sensitive to the specific ORC unit cost when the fuel prices are low. During times with low fuel prices, the lowered cost thereby has a significant impact on the economic feasibility of the ORC unit installation.

The variations of NPV for the jacket water case with a fuel price of 600 \$/t and a specific ORC cost of 4000 \$/kW are depicted in Fig. 17a. The fuel price was the same as in the previous case, while the specific cost represents ORC units with around 50 – 100 kW electrical power output [7,140]. The NPV after 25 years is the largest for the container ship at around 400 kUS\$. Fig. 17b shows that the simple payback period is around 6 years for the three ships considering a fuel price of 600 \$/t. When varying the fuel price, the shortest payback period was obtained by the container ship, contrary to the results obtained in the exhaust gases case. Figs. 17c and 17d show the sensitivity of the economic parameters to the specific cost of the ORC unit for the bulk carrier.

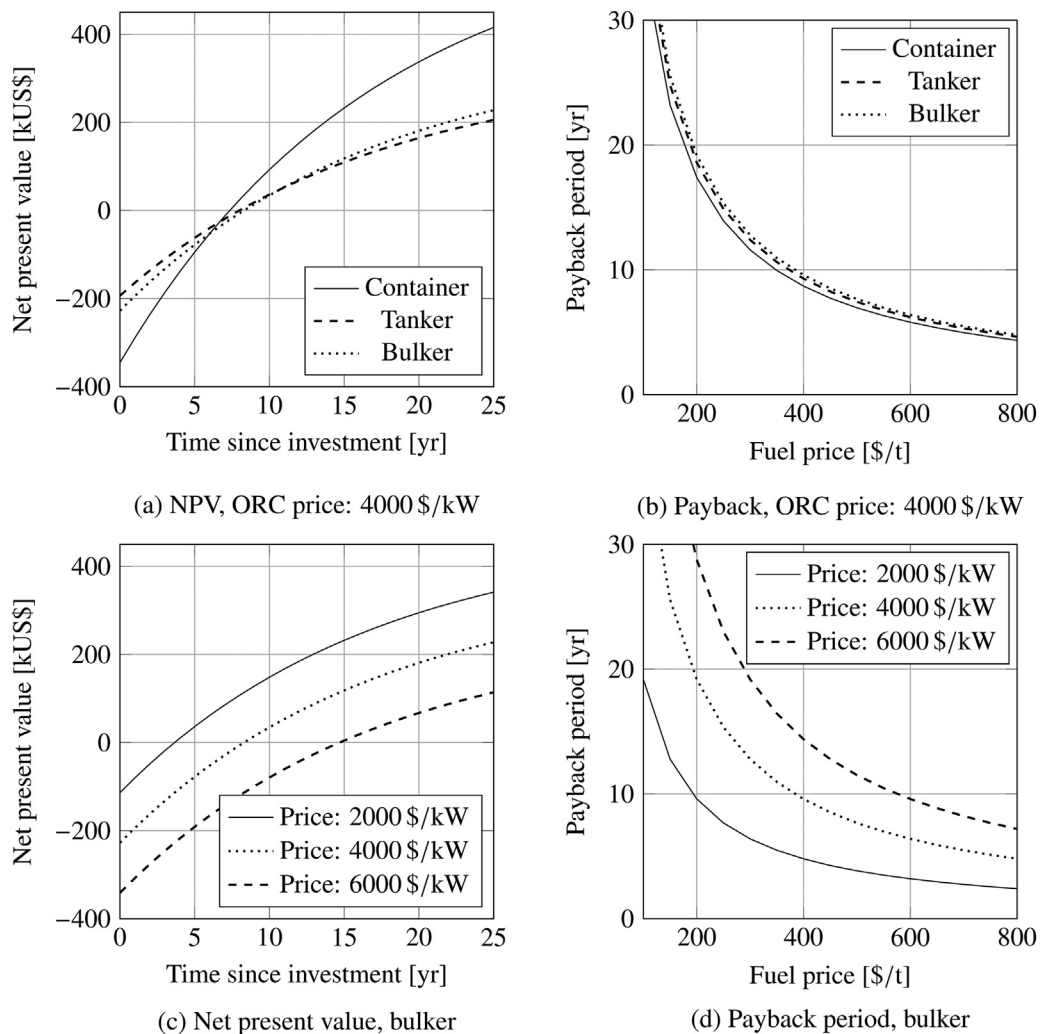

Fig. 17. Results of the economic analysis for the ORC unit fed by the heat from the jacket water.

#### 4.6. Integration on board

Large marine vessels have a number of heating and cooling demands that need to be satisfied. Typical heating requirements include space heating and heat for the fresh water generator, and, those engines using heavy fuel oil require fuel preheating and fuel tank heating. The cooling demands are those related to the cooling of the engine jacket, lubrication oil, scavenge air, and auxiliary engines.

Fig. 4 depicts a typical fresh-water loop and service steam circuit of a marine engine [141]. For the sake of clarity, only one scavenge air cooler is connected to the cooling loop. Circulation pumps, valves, other heat exchangers and bypass lines are not included in the figure.

The purpose of the service steam system is to supply heat on the ship; see the left side of Fig. 4. In the sketch, the heat demands are denoted as heating services. The service steam is produced in a boiler which utilizes the excess heat from the exhaust gases. After delivering the heat to the utilities, the excess steam is condensed in a seawater condenser. The fresh-water generator also requires thermal energy to operate; this is taken from the jacket water loop. The right side of Fig. 4 shows the fresh-water cooling circuit. The cooling loops for the lubrication oil and the jacket water are in series. The circuits supplying the cooling demand to the auxiliary engines and the scavenge air cooler are in parallel and are diverted before the jacket water cooler.

The integration of an ORC unit with the jacket water loop should not affect the operation of the fresh-water generator or impair the cooling of the cylinder liners at any loads. Likewise, the use of an ORC

unit to recover the exhaust gas heat should not impede generating service steam for heating purposes. The integration of an ORC unit for the utilization of scavenge air heat, must be complemented by an additional scavenge air cooler. Thereby, it can be ensured that the air is cooled to the lowest possible temperature acceptable for the engine so as to preserve the performance of the main engine.

The electricity supplied by the ORC unit affects the operation and, thereby, the performance of the auxiliary engines. If the remaining power is supplied to the propeller via a shaft motor, then the running point of the main engine would vary. The change in load set-point of the diesel engines has to be quantified carefully when evaluating the feasibility of the ORC technology. The option of integrating the ORC system to utilize excess heat from the auxiliary engines does also exist, and for this, similar considerations must be made.

Another measure to reduce the emissions of a diesel engine is the use of the exhaust gas recirculation (EGR), where part of the exhaust gases is directed from the exhaust gas receiver to the scavenge air receiver [142]. This technology is widely adopted by diesel engines for automotive applications. The temperature of the recirculated gases is high, thus requiring the use of an EGR cooler. This high temperature heat can be recovered effectively using the ORC technology, as demonstrated by Teng et al. [143] and Lang et al. [144] for heavy-duty diesel engines.

Another current issue of two-stroke marine engines is the damaging of cylinder liners due to cold corrosion. A possible solution is to increase the temperature of the jacket water [145]. Such design

modification allows the ORC unit recuperating the jacket water heat to attain higher energy conversion efficiencies compared to the values achievable with current engines.

Integration of ORC units on ships for WHR can be done by either direct heat exchange with the heat source or using an intermediate loop, for example an oil loop, as mentioned in Section 4.1. On ships, the existing service steam system can be used as an alternative option for integrating ORC units by placing the ORC unit in parallel with the service steam demands. In this scenario, the steam generator should be oversized in order to provide enough steam for both the steam services and the ORC unit. Heat for steam evaporation can be recovered from exhaust gases after the turbochargers and/or from the EGR stream in the case of EGR engines, while scavenge air, jacket water and lube oil heat can be used for feed water preheating. In order to achieve optimum waste heat utilization, the steam pressure should be optimized in order to reach the optimum trade-off between steam temperature and mass flow rate. At high steam pressures the saturation temperature is high and thereby the ORC unit efficiency is high; however, high steam pressures also result in less heat extraction from the waste heat sources and thereby less steam flow to the ORC unit. The integration of ORC units on the service steam system represents a practical solution to harvesting heat from multiple heat sources at different temperatures. However, this integration option generally results in lower WHR unit efficiencies due to increased heat transfer irreversibilities compared to the option of integrating the ORC unit directly with the waste heat sources.

#### 4.7. Alternative fuels

Upcoming technologies for marine machinery systems can offer new possibilities for the ORC technology aboard ships. As mentioned in Section 2, alternative low-sulfur fuels, e.g., low-sulfur MDO or MGO, biofuels, dimethylether (DME), alcohols (e.g., methanol, ethanol), hydrogen, and LNG, may replace the HFO as fuel for the main engine. The use of these alternative fuels may require modifications of the engine and/or engine tuning, which in turn may influence the availability of waste heat sources on board. This section discusses how the use of alternative fuels for propulsion may modify the results given in Section 3 with respect to the expected net power output of ORC units on board, and how their use and integration with the ORC technology can be a step forward towards sustainability in the shipping industry. However, it needs to be stressed that it is not possible to draw quantitative conclusions on how the temperature and mass flow rates of waste heat sources on board are affected by the use of alternative fluids. This is because it is common practice to tune the engines specifically for each fuel in order to minimize the energy losses from the engines and deviate as little as possible from the operating conditions of an engine using a conventional fuel, while complying with legislation regarding NO<sub>x</sub> emissions. Therefore, it would be necessary to know how the engine manufacturing industry would adapt the operation of their engines to the potential upcoming renewable fuels, in order to be able to draw more detailed conclusions about the impact of these fuels on the WHRS onboard. Since such information is not available, this section is limited to the discussion of the effects of alternative fuels on the prospects for WHR primarily in qualitative terms.

Initially, the analysis presented in Section 3 considered the case of a HFO and a low-sulfur fuel, irrespective of their nature. The use of a low-sulfur fuel allows exploiting more waste heat from the exhaust gases, as sulfuric acid condensation is not expected within the operating temperatures, and there is no demand of service steam to preheat the fuel and the fuel tanks. As for the above-mentioned fuels, only MDO and MGO contain sulfur, although in a proportion of less than 0.1% in mass. This sulfur content may generate sulfuric acid condensation only at very low temperatures, and therefore, both MDO and MGO comply with the assumptions made in Section 3 for the minimum boiler feed temperature. As a consequence, the main differentiating factor of these

fuels with regards to WHR on board comes from the distribution and temperature of the available heat sources. For instance, low-sulfur MDO is preheated in the exhaust boilers before its injection in the burner, using about 25% of the energy available in the exhaust gases [87]. Considering the average mass flow rate of exhaust gases in Ref. [87] this could imply a reduction of the exhaust gas temperature of around 80 K, which could reduce the maximum efficiency of the ORC unit. The use of biofuels consisting of vegetable oils (i.e., biodiesel) has been pointed out as a possible alternative to, or in combination with, HFOs, in order to reduce the particle and sulfur emissions without the need of engine modifications [147,148]. A possible increase of NO<sub>x</sub> emissions derived from their use may happen and may be compensated for by retuning the engine, therefore varying the engine operation conditions. However, as of today their use as shipping fuel is marginal due to their high cost and limited availability.

Regarding the use of alcohols and DME as alternative fuels, both the emissions of NO<sub>x</sub> and particles are reduced [148]. In the case of alcohols, the combustion improves due to the presence of oxygen in their molecule, leading to a decrease of the engine heat losses and of the exhaust gas temperatures [149], which could affect the maximum efficiency of the ORC unit. Although both methanol and ethanol have been suggested as potential alternative fuels for ships, so far there is no usage of ethanol on commercial vessels [149]. Methanol is widely available, can be produced both from natural gas and renewable resources, and as it is liquid at ambient temperature its storage and distribution are similar to conventional fuels. However, the use of methanol requires adaptation of the engines, larger storage tanks, and its toxicity and corrosivity requires stricter safety measures [148]. Methanol can be used in internal combustion engines blended with another fuel or in a dual-fuel engine. According to the MAN Diesel CEAS engine calculation tool [54] engines working with methanol present relatively lower flow rates of exhaust gases, which would reduce the potential for power conversion with an ORC unit. Currently, a number of companies (i.e., Stena Line, Wärtsila and MAN Diesel & Turbo) are working on adapting their diesel engines for operation with methanol as a fuel [150].

Dimethyl ether (DME), which is a liquefied gas with similar characteristics as liquefied petroleum gas, can be derived from both natural gas and biomass resources, is non-toxic, and conversely to methanol, can be directly used in diesel engines using liquefied petroleum gases. As a disadvantage, both DME and methanol, present heating values lower than MDO (29 MJ/kg and 22.7 MJ/kg, respectively, compared to approximately 45 MJ/kg), thus requiring the consumption of higher amounts of fuel, although NO<sub>x</sub> emissions are reported to be lower [152]. An additional consideration for DME and methanol, and other fuels that do not produce soot during combustion, is that the lack of soot allows for extensive use of EGR for reduction of NO<sub>x</sub> emissions without compromising the engine reliability due to soot deposition in the EGR cooler and the scavenging chamber. The use of high rates of EGR tends to increase the exhaust gas temperature without any penalty in fuel consumption of the engine. Owing to the increased exhaust gas temperatures, the potential for WHR of the exhaust gases is increased when using fuels that do produce any soot.

Hydrogen is a gaseous fuel, well-known as a renewable energy carrier, with a high heating value. However, its high self-ignition temperature makes it unfeasible for direct use in existing engines, but it is an ideal fuel if it is combined with others [151]. The main disadvantage that it presents is that the storage tanks of compressed hydrogen require 6–7 times more space those of standard HFOs, making it more challenging to integrate WHR systems on board.

Liquefied natural gas (LNG) is claimed to have the greatest potential as an alternative fuel due to its zero emissions of SO<sub>x</sub>, lower emissions of NO<sub>x</sub>, large availability worldwide, and a more competitive price compared to distillates [148]. Fig. 18 illustrates the increasing orders of LNG fueled ships registered by DNV-GL [146]. As for disadvantages, LNG requires more expensive tanks and piping, and increased port

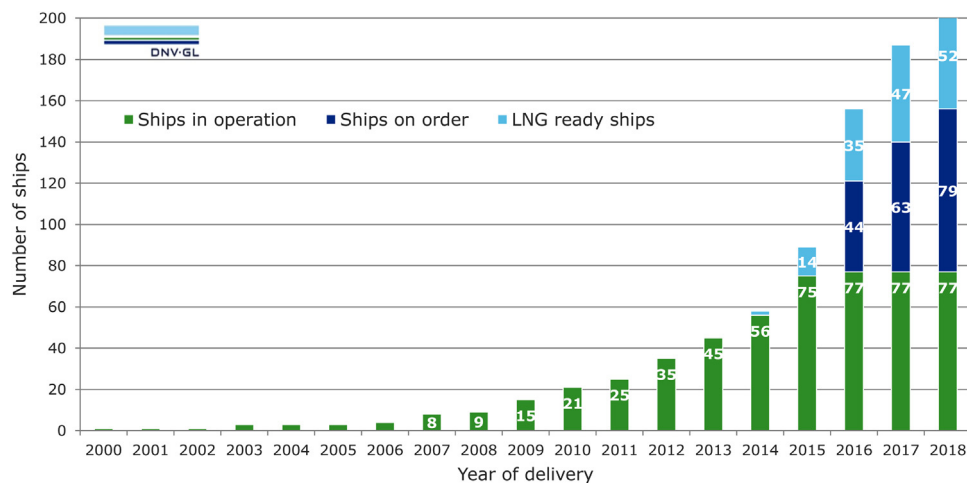

Fig. 18. LNG ships in operation and on order excluding LNG carriers [146].

times which may imply higher voyage speeds. However, LNG (similarly to methanol, DME and MGO) does not require preheating in exhaust boilers, making it a representative fuel for the analysis presented for a low-sulfur fuel in Section 3.

On LNG fueled ships, the LNG is stored at temperatures around  $-160\text{ }^{\circ}\text{C}$  and needs to be preheated prior to burning. The preheating of the LNG may represent a potential cold source which can be used on the condenser side of an ORC unit to increase the thermal efficiency of the ORC unit by reducing the condensation temperature. However, the amount of fuel flow to the engine is typically low, meaning that the use of LNG cold energy would result in ORC units with high efficiency, but low power outputs. Baldasso et al. [153] investigated the possibility of designing ORC units rejecting heat to both the seawater and the LNG cold flow, and found that this solution could increase the ORC power output by about 6% compared to the standard configuration rejecting heat only to the seawater. If the fuel flow required by the engine is higher than the boil-off gases generated by the heat transfer to the storage tank, the fuel preheating entails the evaporation of LNG. In this case, the power supplied by the ORC unit can be higher than if only the boil-off gases are exploited. Sung et al. [154] investigated the potential of utilizing the temperature difference between the boil-off gases of a LNG tanker and the exhaust gases of a 17.1 MW Wärtsilä DF50 engine using an ORC unit. They compared the performance of eight different working fluids, and found that the refrigerant R218 gave the highest net power output (49.8 kW).

#### 4.8. Commercial products

A large number of ORC suppliers offer products for WHR from on-land reciprocating engines. Quoilin et al. [8] and Ve'lez et al. [15] provided a comprehensive list of the manufacturers and their commercial units. In the present paper, only the ORC products which are tailored to the marine market are considered.

Calnetix Technologies and Mitsubishi Heavy Industries offer an ORC

unit to recuperate the jacket water heat; see Table 4. One unit was purchased and installed by A.P. Møller - Mærsk on their Arnold Mærsk container vessel in April 2016 [9]. Calnetix Technologies and Mitsubishi Heavy Industries also prospect the development of ORC units for scavenge air and exhaust gas applications [155]. In 2015, Enertime received funding from the EU to tailor their on-land ORC products to the marine market [156]. The heat source can be either the exhaust gas or the jacket water heat [157]. Their ORC system employs an axial turbine and R245fa as the working fluid [158]. Kobe Steel has recently received the approval of their ORC unit from Japan's ship classification society. One WHRS was installed aboard the coal carrier Asahi Maru. The working fluid used in the unit is R245fa, and the power output is 125 kW [159]. The class certificate reports that the design pressure of the expander is 1.99 MPa [159]. At this pressure, the fluid R245fa has a saturation temperature of  $124\text{ }^{\circ}\text{C}$ , indicating that the system is intended for scavenge air and/or exhaust gas heat recovery. The unit employs a screw expander.

Between 2011 and 2012, Opcon AB installed and tested their ORC technology for utilization of jacket water aboard the Figaro Wallenius. Their unit uses R236fa as the working fluid [160] and the expander is a Lysholm turbine.

### 5. Alternative waste heat recovery systems

In this section, a number of works studying the use of SRC units, KC plants and other relevant technologies for marine applications are reviewed. The purpose is to compare these plants with the ORC technology. The reader is referred to Shu et al. [39] and Singh and Pedersen [40] for a more comprehensive review of alternative WHR technologies for two-stroke engines on ships.

#### 5.1. Steam Rankine cycle plants

As outlined in Section 4.6, ships are typically equipped with a steam

Table 4

List of ORC manufacturers targeting the marine market.

Manufacturer	Heat source	Power [kW]	Fluid	Expander	Vessel
Calnetix Technologies	Jacket water	$\leq 125$	R245fa	Radial turbine	Arnold Mærsk <sup>b</sup>
Enertime jacket water	Exhaust gases,	100–5000	R245fa turbine	Axial	–
Kobe Steel	NA <sup>a</sup>	$\leq 125$	R245fa	Screw	Asahi Maru <sup>c</sup>
Opcon	Exhaust gases, jacket water, scavenge air, condensate	200–800	Ammonia R236fa	Lysholm turbine	Figaro Wallenius

<sup>a</sup> Information not available.

<sup>b</sup> The ORC unit was installed on board by April 2016.

<sup>c</sup> Sea trials were completed by December 2016.

boiler to supply heat on board. A natural extension to the steam boiler is to add a superheater section and a steam turbine. Several global players of the marine industry [161–164] proposed the use of dual-pressure SRC power systems promising efficiency gains of around 12%, when combining the SRC unit with an exhaust PT. This figure is confirmed by a number of research works. For example, Dimopoulos et al. [165] presented a detailed study of a SRC plant by considering the system performance at different engine loads. They showed that the WHRS allows increasing the thermal efficiency by about 5% points, corresponding to an increase in performance of 12%.

In this case, the heat sources powering the SRC unit are the exhaust gases, scavenge air, and jacket water heat. Simpler configurations were also investigated. Theotokatos and Livanos [166] presented a techno-economic analysis of a single-pressure SRC unit to recover the waste heat from two-stroke and four-stroke engines. They considered loads ranging from 50% to 100%. The WHRS was fed by the scavenge air and exhaust gas heat. On the two-stroke engine, using a SRC enables increasing the thermal efficiency of the vessel energy system by 0.8–1.4%. This improvement on the thermal efficiency can be boosted by up to 3% in the case of four-stroke engines. Hou et al. [167] systematically analyzed four WHRS configurations: 1) no WHRS, 2) PT, 3) single-pressure SRC unit, and 4) PT and single-pressure SRC unit. The application of a variable geometry power turbine was also analyzed. The electrical outputs of systems 2, 3 and 4 were found to be 4.3%, 3.5%, and 9.8% of the main engine power, respectively.

The aforementioned studies indicate that a single-pressure SRC plant can be nearly as efficient as a dual-pressure one, and that the PT is of key importance for the WHRS efficiency. Moreover, the SRC unit strongly relies on the high-temperature exhaust gas heat to remain a feasible option. Also, it should be pointed out that SRCs are, in practice, shut off when the engine loads are below 50%, which implies that the potential fuel savings with the use of SRCs would be minor considering the current slow steaming operations.

Andreasen et al. [52] carried out a comparison of the ORC and dual-pressure SRC processes for WHR on engines using high-sulfur and low-sulfur fuels. The comparison included considerations about the turbine efficiency and indicated that more efficient turbines employing few turbine stages are possible for organic fluids. In the high-sulfur fuel case, the ORC technology is challenged due to requirements for service steam production and a high boiler feed temperature. However, if it is assumed that the turbine efficiency is 10% points larger for the ORC unit than for the SRC unit, the performances are similar. For the low-sulfur fuel case, both WHR technologies produced significantly more power compared to the high-sulfur fuel case. The design power of the SRC unit increased by 18%, while it increased by 33% for the ORC unit using MM as the working fluid. A comparison between an ORC unit using cis-pentane (with 72% turbine design efficiency) and the dual-pressure SRC unit (with 62% turbine design efficiency) suggested higher performance for the ORC unit at all main engine loads.

## 5.2. Kalina cycle plants

The KC plant, with its ammonia-water mixture working fluid, is claimed to be more efficient than the SRC counterpart in various research articles. One example is the doctoral thesis by Jonsson [168] where a thermodynamic comparison of KC and SRC layouts for WHR on large marine four-stroke engines was carried out. It was concluded that the KC plant can supply 40–50% more power than a single-pressure SRC unit, and 20–25% more than a dual-pressure one.

Bombarda et al. [169] compared a KC system with an ORC unit for WHR on large marine four-stroke engines. They found that the two plants have similar power outputs. However, they pointed out that the KC unit has important drawbacks compared to the ORC counterpart: i) it has a higher complexity, ii) it requires using more bulky heat exchangers, and iii) it operates at higher working pressures. More recently, Larsen et al. [81] compared a dual-pressure SRC plant with a KC

and an ORC unit for a large two-stroke ship engine. The thermal power of the exhaust gases, scavenge air and jacket water was exploited. The results suggested that the ORC module can produce 7% more power than the SRC and KC plants. A number of qualitative aspects were also compared, suggesting that the KC system does not provide any significant advantage over the ORC and SRC plants.

For low-temperature applications, Becquin and Freund [170] presented a thermodynamic investigation of a number of ORC and KC plant layouts. The results indicate that the KC technology can convert 30–50% more power if the heat source temperatures are around 80–90 °C. Unlike Bombarda et al. [169], Becquin and Freund [170] did not find any drawbacks with respect to the HEX area. In this regard, it was found that the literature on KC plants shows contradictory results concerning the claimed advantages. For ship applications, the high toxicity of ammonia is an important drawback of the KC technology. It is also worth considering that the KC is a patented technology.

## 5.3. Other technologies

The use of other technologies for WHR on ships is currently under investigation. For instance, a new technology for WHR on ships is the one developed by Climeon AB [171]. The unit consists of an ORC-like cycle where the evaporation and condensation are replaced with desorption and absorption processes. This allows achieving high conversion efficiencies at low cost. The company has newly installed one unit aboard the cruise ship Viking Grace. The heat source of the WHRS is the high temperature jacket cooling water from the LNG main engines. The thermal efficiency of the system is 10% with an inlet temperature of the heat source of 90 °C and a seawater temperature of 20 °C [171].

Thermoelectric generators have been also recently proposed as a potential technology for marine WHR [39,172]. Nevertheless, only a few theoretical studies have been carried out, and no unit has been installed aboard ships yet. The main reason is the low energy conversion efficiencies (typically around 5%) and the high investment cost. Shu et al. [39] suggested using this technology to exploit the temperature difference between the exhaust gases and seawater. In an innovative application, Shu et al. [173] combined the use of thermoelectric generators with ORC plants using the exhaust gases of an internal combustion engine. They claimed that this electric device can be used to cover the electrical demand of the ORC pump, but at the expense of an increase in investment costs. Loupis et al. [174] evaluated a prototype WHRS based on thermoelectric generators for marine power systems. They concluded that such technology can be economically viable if energy conversion efficiencies around 6.4% are achieved.

Another option is the so-called trilateral cycle. Here the working fluid is heated in the liquid phase, and starts expanding from saturated liquid conditions [175]. Given the absence of isothermal evaporation, this feature makes this cycle ideal to harvest the heat from the exhaust gases, as they can be cooled by a temperature difference of up to 100 °C. Choi and Kim [73] studied the use of a water trilateral cycle plant fed by the exhaust gas heat of a marine engine. The system was combined with a bottoming ORC unit. Although no trilateral cycle plant is currently in operation, several works have pointed out that this cycle could attain higher thermal efficiencies than the ORC counterpart (i.e., between 35% and 15% more for heat source temperatures of 115 °C and 160 °C, respectively) [176–178]. In order to realize the trilateral cycle, further research needs to be conducted to enhance the isentropic efficiency of expanders operating in the two-phase region.

## 6. Challenges and future R&D areas

As shown in Section 3, the ORC technology can be a viable alternative to recuperate the heat from the jacket water and the exhaust gases.

The economic viability strongly depends on the fuel price and the

investment cost of the ORC unit. Given the high volatility of fuel prices, the way to enhance the economic feasibility is to decrease the specific cost of the WHRS. This can be accomplished by improving the system performance, e.g., adopting mixtures as the working fluid or supercritical cycles, while simultaneously abating the purchase cost of the components. There may be prospects for attaining the latter by employing alternative manufacturing processes and materials. A trade-off often exists between power output and total investment cost. The payback period can thus be minimized by adopting multi-objective optimization methods; see, e.g., Pierobon et al. [103]. Geometrical constraints, such as space and weight availability on ships, can also be added to the set of considerations.

At this end, the traditional design work-flow whereby one: (i) selects the fluid, (ii) designs the thermodynamic cycle, and (iii) performs the preliminary design of the heat exchangers and the turbine based on the output of the previous phase, proves to be inadequate. For instance, a thermodynamic cycle with a high expansion ratio may achieve better conversion efficiency, whilst it can result in a turbine with a high number of stages and prohibitive production costs. Similarly, a too bulky heat exchanger may not fit within the area available in the engine room. Hence, the more adequate approach is to carry out the optimization of the cycle and the components simultaneously. Pioneering configurations of the marine energy system that integrate the ORC system with other energy systems aboard, e.g., the refrigeration system for reefer containers, shall also be devised. For this purpose, Prater [179] listed three prerequisites for WHRSs: (i) minimal losses from the heat en route to the conversion unit, (ii) efficient vapor expansion, and (iii) limited system complexity. These aspects point towards the design and optimization of the engine and the WHRS as a whole. The Still engine, combining these three prerequisites, is one example of such approach [180]. Steam, generated from waste heat, is expanded under the piston to reduce compression work in a marine diesel engine. This, in turn, improves the thermal efficiency of the system. Prater [179] proposed an integrated six-stroke piston engine and a WHRS. The modelled efficiency was 56%, a significant increase from a 38% baseline. Conklin and Szybist [181] studied a six-stroke concept where water was injected directly into the cylinder, thus using the exhaust heat to produce additional power. In these examples, no costly turbine is required. More recently, Larsen et al. [182] embraced these prerequisites in a proposal to integrate the ORC expansion process into a two-stroke marine main engine design by using an engine cylinder as the expander. Thus, the need for the generator, turbine and electrical equipment could be removed and thereby entail a 50% reduction in the ORC capital costs and fuel savings up 8.3%.

In a recent study, Larsen et al. [59] compared the performance of five different main engine configurations, two of which included ORC units for exhaust heat recovery. The design and tuning of the main engine and the design of the ORC units were optimized in a multi-objective optimization considering minimization of  $\text{NO}_x$  emissions and specific fuel oil consumption. The results indicate that for the combined cycle (main engine and ORC unit) fuel savings of up to  $3.5 \text{ g kWh}^{-1}$  can be obtained if the main engine fuel consumption is increased by  $0.5\text{--}1 \text{ g kWh}^{-1}$ . Further research is required to fulfill this potential, for example, by investigating to what extent such tuning could be done in practice and what barriers exist.

With regards to the use of alternative fuels, in order to maximize the performance of the whole machinery system, its optimization and the engine design and tuning, need to be accomplished simultaneously by considering the whole energy system on board the vessel. By employing such approach, it is possible to adapt the engine design and tuning for the WHR system, and take advantage of the possibilities for integration of the fuel system with the WHR system. For the combined optimization of WHR systems and engines using alternative fuels, for which previous operational experience is scarce, accurate simulation tools need to be developed in order to predict the effects of engine tuning on the performance and the formation of  $\text{NO}_x$  emissions for different fuels. In the

case of vessels running on highly flammable gases such as natural gas or hydrogen, safety and classification requirements need to be carefully considered with respect to the placement of the ORC unit (possibly using a flammable working fluid) on board the vessel. These precautions (e.g., double piping, placement of the ORC unit in a separate gastight compartment) may result in a more expensive installation. In the case of an LNG engine, where the ORC unit could utilize the LNG as the cold source, a number of crucial aspects in addition to the safety and classification requirements would need to be addressed for its practical implementation. These include the design of expanders tailored for a high-pressure ratio, and the derivation of control strategies suitable for ORC units using the varying LNG fuel flow rate as a heat sink. Additionally, ship voyage pattern-based optimizations are relevant. Baldi et al. [60] analyzed the importance of optimizing the system considering the engine operational strategy and ship voyage speed. The optimization of an ORC unit considering only the design-point speed gives fuel savings of 7%. Conversely, the results indicate that this value can be increased to 11% when optimizing the design taking into account the ship voyage.

As for the working fluid, the main challenge is to comply with the environmental and safety requirements. For instance, the most suitable compounds to recover the exhaust gas heat are hydrocarbons. These have a high flammability risk. Research on new non-flammable fluids tailored to marine applications should be carried out considering, e.g., HFOs with a higher number of carbon atoms. For the low-temperature heat sources, the new working fluids (HFOs) with low ODP and GWP are viable alternatives. Most of them are non-toxic, and have a low or moderate flammability risk. Currently, refrigerant manufacturers are working on the development of HFO blends suitable for retrofitting HFCs, such as R410A or R134a. These fluids are expected to be commercially available in the coming years. The development of equations of state and correlations for the thermophysical property estimation of these new fluids could reduce the current uncertainty about their practical performance, clarifying their potential prospects for utilization aboard ships.

Another issue hindering the use of environmentally-friendly fluids is their high price. In this regard, the manufacturing cost seems to increase with the number of fluorine and carbon atoms that the molecules contain. Bivens and Minor [183] pointed out that the manufacturing costs of the new generation of replacements could be higher than those of HFCs. However, the cost of the fluids currently in use will increase as a consequence of supply shortages [184]. This situation will arguably drive the change towards the new generation of fluids.

## 7. Conclusions

This work presents a detailed literature survey of research works on the use of organic Rankine cycles for waste heat recovery on board ships, and provides an analysis of the potential and the challenges of using this technology in retrofitting current vessels and in new-buildings. The available waste heat and the recoverable energy were estimated for three representative operating vessels. Guidelines on the integration on board and on the selection of the optimal cycle architecture, working fluid, components, and control strategy were provided. The economic feasibility was also estimated, and the constraints imposed by the integration on board were presented. Finally some alternative WHR technologies were reviewed, and potential R&D areas in this field were enumerated.

The analysis in this paper indicates that the jacket cooling water and the exhaust gases of the engine are the most suitable heat sources for ORC systems on board ships. Particularly, waste heat recovery from the exhaust gases from engines using low-sulfur fuels can be very promising, with estimated voyage fuel savings of around 10%, although savings of up to 15% are expected, since more advanced design methods in the short term have the potential to boost the ORC performance. ORC units recovering the heat of jacket cooling water would

preferably have a simple configuration, with plate HEXs, and use HFOs or, eventually hydrocarbons, as working fluids. The units used for WHR of the exhaust gases and other high temperature sources would preferably use shell and tube HEXs and a regenerator, and hydrocarbons or siloxanes as working fluids. The ORC technology stands out over the steam Rankine cycle and the Kalina cycle because of its capacity of recovering low-temperature heat and its simpler design, and outranks the rest of waste heat recovery technologies presented due to its level of maturity. Alternative manufacturing processes and materials, advances in the design methods of the ORC unit components, and new process integrations of the units within the energy system of the ship, considering the potential future use of alternative fuels, are needed to further enhance the economic viability of ORC systems and facilitate their integration on board. New working fluids shall also be investigated in order to reduce the flammability risk associated with the ORC unit, and to comply with the increasingly restrictive regulations on their environmental impact.

## Acknowledgements

The work documented in this paper has been funded by Den Danske Maritime Fond with the project Pilot ORC, project ID: 2015-070; DTU Mekanik, Organic Recycle Unit ([www.pilotORC.mek.dtu.dk](http://www.pilotORC.mek.dtu.dk)), Innovationsfonden with the THERMCYC project ([www.thermcyc.mek.dtu.dk](http://www.thermcyc.mek.dtu.dk), project ID: 1305-00036B), and the European Union's Horizon 2020 research and innovation programme with a Marie Skłodowska-Curie Fellowship under grant agreement No 704201 ([www.nanoorc.mek.dtu.dk](http://www.nanoorc.mek.dtu.dk), project NanoORC). Some funding has also been provided by Signe och Olof Wallenius Stiftelse. The financial support is gratefully acknowledged. In addition, we thank Peter Sinding, Dampskibsselskabet NORDEN A/S, Denmark, for providing vessel load profiles, and Hans Otto Holmegaard Kristensen, Department of Mechanical Engineering, Technical University of Denmark, for providing useful information and guidance on shipping in general. Rasmus Frimann Nielsen, Mærsk, is thanked for providing information on representative load profiles for container vessels. We also thank Kim Nørby Christensen, Odense Maritime Technology, Denmark, for providing useful input regarding the estimations of the potential of installing ORC units on ships. Bent Ørdrup Nielsen, MAN Diesel & Turbo, Denmark, is thanked for being always available with knowledge on marine engines and shipping in general. Data of the world fleet and ship characteristics were retrieved from The Clarksons Research World Fleet Register dataset. Finally, the permission to publish graphical material from Alfa Laval and DNV-GL is acknowledged.

## References

- [1] International Chamber of Shipping, <[www.ics-shipping.org](http://www.ics-shipping.org)>, [accessed 6 August 2015].
- [2] World Shipping Council. The Liner Shipping Industry and Carbon Emissions Policy; 2009.
- [3] Smith TWP, Jalkanen JP, Anderson BA, Corbett JJ, Faber J, Hanayama S, O'Keefe E, Parker S, Johansson L, Aldous L, Raucci C, Traut M, Ettinger S, Nelissen D, Lee DS, Ng S, Agrawal A, Winebrake JJ, Hoen M, Chesworth S, Pandey A. Third IMO greenhouse gases study 2014, Tech. rep. London, United Kingdom: The International Maritime Organization; 2015.
- [4] Smith TWP, Jalkanen JP, Anderson BA, Corbett JJ, Faber J, Hanayama S, O'Keefe E, Parker S, Johansson L, Aldous L, Raucci C, Traut M, Ettinger S, Nelissen D, Lee DS, Ng S, Agrawal A, Winebrake JJ, Hoen M, Chesworth S, Pandey A. Reduction of GHG emissions from ships, Tech. rep. London, United Kingdom: International Maritime Organization; 2014.
- [5] IHS Maritime 360, <[www.ihs-maritime360.com](http://www.ihs-maritime360.com)>, [accessed 6 August 2015].
- [6] Det Norske Veritas. Energy management study, Tech. rep. Det Norske Veritas; 2015.
- [7] Colonna P, Casati E, Trapp C, Mathijssen T, Larjola J, Turunen-Saaresti T, Uusitalo A. Organic Rankine cycle power systems: from the concept to current technology, applications, and an outlook to the future. *ASME J Gas Eng Turbines Power* 2015;137(10):1–19.
- [8] Quoilin S, Broek MVD, Declaye S, Dewallef P, Lemort V. Techno-economic survey of organic Rankine cycle (ORC) systems. *Renew Sustain Energy Rev* 2013;22:168–86.

- [9] Technical University of Denmark, Project PilotORC [accessed 18 August 2016].
- [10] Angelino G, Gaia M, Macchi E. A review of Italian activity in the field of organic Rankine cycles. *VDI-Ber* 1984;539:465–82.
- [11] Saha B, Chakraborty B. Utilization of low-grade waste heat-to-energy technologies and policy in Indian industrial sector: a review. *Clean Technol Environ Policy* 2017;19(2):327–47.
- [12] Colonna P, Casati E, Trapp C, Mathijssen T, Larjola J, Turunen-Saaresti T, Uusitalo A. Organic Rankine cycle power systems: a review. *Proc Int Conf Power Eng (ICOPE)* 2015.
- [13] Linke P, Papadopoulos AI, Seferlis P. Systematic methods for working fluid selection and the design, integration and control of organic Rankine cycles—a review. *Energies* 2015;8(6):4755–801.
- [14] Saadatfar B, Fakhrai R, Fransson T. Waste heat recovery organic Rankine cycles in sustainable energy conversion: a state-of-the-art review. *J MacroTrends Energy Sustain* 2013;1(1):161–88.
- [15] Velez F, Segovia JJ, Martin MC, Antolin G, Chejne F, Quijano A. A technical, economical and market review of organic Rankine cycles for the conversion of low-grade heat for power generation. *Renew Sustain Energy Rev* 2012;16(6):4175–89.
- [16] Chen H, Goswami DY, Stefanakos EK. A review of thermodynamic cycles and working fluids for the conversion of low-grade heat. *Renew Sustain Energy Rev* 2010;14(9):3059–67.
- [17] Zhai H, An Q, Shi L, Lemort V, Quoilin S. Categorization and analysis of heat sources for organic Rankine cycle systems. *Renew Sustain Energy Rev* 2016;64:790–805.
- [18] Tchanché BF, Lambrinos G, Frangoudakis A, Papadakis G. Low-grade heat conversion into power using organic Rankine cycles - a review of various applications. *Renew Sustain Energy Rev* 2011;15(8):3963–79.
- [19] Ebrahimi K, Jones G, Fleischer A. A Rev challenging Issues Integr Absorpt Refrig Org Rank Cycle into A data Cent Cool Syst 2014;1047–54.
- [20] Villarini M, Bocci E, Moneti M, Di Carlo A, Micangeli A. State Art small Scale Sol Power Org Syst: A Rev Differ Typol Technol Perspect 2014;4:45:257–67.
- [21] Bronicki L, Nett CN, Nordquist J. Electricity generation from fuel cell waste heat using an Organic Rankine Cycle. *ASME 2014 Proceedings of the 12th International Conference on Fuel Cell Science, Engineering and Technology* collocated with the ASME 2014 8th International Conference on Energy Sustainability, Boston (USA), 2014, pp. V001T04A005.
- [22] Dong L, Liu H, Riffat S. Development of small-scale and micro-scale biomass-fuelled CHP systems - a literature review. *Appl Therm Eng* 2009;29(11–12):2119–26.
- [23] Zywicka G, Kaczmarczyk T, Ichnatowicz E. A review of expanders for power generation in small-scale organic Rankine cycle systems: performance and operational aspects. *Proc Inst Mech Eng, Part A: J Power Energy* 2016;230(7):669–84.
- [24] Imran M, Usman M, Park BS, Lee DH. Volumetric expanders for low grade heat and waste heat recovery applications. *Renew Sustain Energy Rev* 2016;57:1090–109.
- [25] Öhman H, Lundqvist P. Screw expanders in ORC applications, review and a new perspective, in: *Proceedings of the 3rd International Seminar on ORC Power Systems, Bruxelles, Belgium, 2015*, pp. 1–10.
- [26] Song P, Wei M, Shi L, Danish SN, Ma C. A review of scroll expanders for organic Rankine cycle systems. *Appl Therm Eng* 2014;75:54–64.
- [27] Saghatoun S, Zhuge W, Zhang Y. Review of expander selection for small-scale organic Rankine cycle. In *ASME 2014 Proceedings of the 4th Joint US-European Fluids Engineering Division Summer Meeting* collocated with the ASME 2014 12th International Conference on Nanochannels, Microchannels, and Minichannels, Chicago (USA), 2014, pp. V01BT10A041.
- [28] Bao J, Zhao L. A review of working fluid and expander selections for organic Rankine cycle. *Renew Sustain Energy Rev* 2013;24:325–42.
- [29] Modi A, Haglind F. A review of recent research on the use of zeotropic mixtures in power generation systems. *Energy Convers Manag* 2017;138:603–26.
- [30] Sarkar J, Bhattacharyya S. Potential of organic Rankine cycle technology in India: working fluid selection and feasibility study. *Energy* 2015;90:1618–25.
- [31] Lecompte S, Huisseune H, van den Broek M, Vanslambrouck B, De Paep M. Review of organic Rankine cycle (ORC) architectures for waste heat recovery. *Renew Sustain Energy Rev* 2015;47:448–61.
- [32] Ziviani D, Beyene A, Venturini M. Advances and challenges in ORC systems modeling for low grade thermal energy recovery. *Appl Energy* 2014;121:79–95.
- [33] Rahbar K, Mahmoud S, Al-Dadah RK, Moazami N, Mirhadizadeh SA. Review of organic Rankine cycle for small-scale applications. *Energy Convers Manag* 2017;134:135–55.
- [34] Tocci L, Pal T, Pasmazoglou I, Franchetti B. Small Scale Organic Rankine Cycle (ORC): a techno-economic review. *Energies* 2017;10(4):413.
- [35] Liang LH. The Economics of Slow Steaming. *Seatrade Maritime News*; 2014.
- [36] Saidur R, Rezaei M, Muzammil W, Hassan M, Paria S, Hasanuzzaman M. Technologies to recover exhaust heat from internal combustion engines. *Renew Sustain Energy Rev* 2012;16(8):5649–59.
- [37] Sprouce C, Depcik C. Review of organic Rankine cycles for internal combustion engine exhaust waste heat recovery. *Appl Therm Eng* 2013;51(1):711–22.
- [38] Wang T, Zhang Y, Peng Z, Shu G. A review of researches on thermal exhaust heat recovery with Rankine cycle. *Renew Sustain Energy Rev* 2011;15(6):2862–71.
- [39] Shu G, Liang Y, Wei H, Tian H, Zhao J, Liu L. A review of waste heat recovery on two-stroke IC engine aboard ships. *Renew Sustain Energy Rev* 2013;19:385–401.
- [40] Singh DV, Pedersen E. A review of waste heat recovery technologies for maritime applications. *Energy Convers Manag* 2016;111:315–28.
- [41] Bouman EA, Lindstad E, Riialand AI, Strømman AH. State-of-the-art technologies, measures, and potential for reducing GHG emissions from shipping – a review. *Transp Res Part D: Transp Environ* 2017;52:408–21.
- [42] Pili R, Romagnoli A, Kamossa K, Schuster A, Spliethoff H, Wieland C. Organic

- Rankine Cycles (ORC) for mobile applications—Economic feasibility in different transportation sectors. *Appl Energy* 2017;15(204):1188–97.
- [43] The Clarksons Research World Fleet Register, <www.wfr.clarksons.net>, [accessed 8 August 2016].
- [44] The International Maritime Organisation. Technical and operational measures to improve the energy efficiency of international shipping and assessment of their effect on future emissions, Tech. rep. The International Maritime Organisation; 2011.
- [45] The International Maritime Organisation. 2014 guidelines on the method of calculation of the attained energy efficiency design index (EEDI) for new ships, Tech. rep. The International Maritime Organisation; 2014.
- [46] The International Maritime Organisation. Sulphur oxides (SO<sub>x</sub>) Regulation 14, Tech. rep. The International Maritime Organisation; 2015.
- [47] The International Maritime Organisation. Nitrogen Oxides (NO<sub>x</sub>) Regulation 13, Tech. rep. The International Maritime Organisation; 2015.
- [48] The International Maritime Organisation. Amendments to the technical code on control of emission of nitrogen oxides from marine diesel engines, Tech. rep. The International Maritime Organisation; 2008.
- [49] Psarafitis HN, Kontovas CA. CO<sub>2</sub> Emission Statistics for the World Commercial Fleet. *WMU J Marit Aff* 2009;8(1):1–25.
- [50] Dokkum KV. *Ship Knowledge: A Modern Encyclopedia*, Dokmar, ISBN: 9789080633025; 2003.
- [51] ABS, <www.eagle.org>, [accessed 6 August 2015].
- [52] Andreasen JG, Meroni A, Haglind F. [547]. *A Comp Org Steam Rank Cycle Power Syst Waste Heat Recovery Large ships* 2017;10(4):1–23.
- [53] Christensen K. Private communication; 2016.
- [54] MAN Diesel & Turbo, <http://marine.man.eu/two-stroke/ceas>, [accessed 6 August 2015].
- [55] Yuksek EL, Mirmobin P. Waste heat utilization of main propulsion engine jacket water in marine application, in: *Proceedings of the 3rd International Seminar on ORC Power Systems, Bruxelles, Belgium, 2015*, pp. 1–10.
- [56] Angelino G, Gaia M, Macchi E. Medium temperature 100 kW ORC engine for total energy systems. In: Ehringer H, Hoyaux G, Pilavachi PA, editors. *Energy Conservation in Industry - Combustion. Heat Recovery and Rankine Cycle Machines*; 1983. p. 177–89.
- [57] MAN Diesel & Turbo. *Waste Heat Recovery System (WHRS) for Reduction of Fuel Consumption, Emissions and EEDI*, Tech. rep. MAN Diesel & Turbo; 2015.
- [58] Macchi E. Design criteria for turbines operating with fluids having a low speed of sound, *Von Karman Inst. for Fluid Dyn. Closed Cycle Gas Turbines*, 2; 1977.
- [59] Larsen U, Pierobon L, Baldi F, Haglind F, Ivarsson A. Development of a model for the prediction of the fuel consumption and nitrogen oxides emission trade-off for large ships. *Energy* 2015;80:545–55.
- [60] Baldi F, Larsen U, Gabrielli C. Comparison of different procedures for the optimisation of a combined Diesel engine and organic Rankine cycle system based on ship operational profile. *Ocean Eng* 2015;110:85–93.
- [61] Bronicki L. Organic Rankine cycles in geothermal power plants 25 years of Ormat experience. *GRC Trans* 2007;31:499–502.
- [62] Yang MH, Yeh RH. Thermo-economic optimization of an organic Rankine cycle system for large marine diesel engine waste heat recovery. *Energy* 2015;82:256–68.
- [63] Yang MH, Yeh RH. Thermodynamic and economic performances optimization of an organic Rankine cycle system utilizing exhaust gas of a large marine diesel engine. *Appl Energy* 2015;149:1–12.
- [64] Ahlgren F, Mondejar ME, Genrup M, Thern M. Waste heat recovery in a cruise vessel in the Baltic Sea by using an organic Rankine cycle: a case study. *ASME J Gas Eng Turbines Power* 2015;138:1–10.
- [65] Shu G, Liu P, Tian H, Wang X, Jing D. Operational profile based thermal-economic analysis on an Organic Rankine cycle using for harvesting marine engine's exhaust waste heat. *Energy Convers Manag* 2017;146:107–23.
- [66] Yang MH. Optimizations of the waste heat recovery system for a large marine diesel engine based on transcritical Rankine cycle. *Energy* 2016;113:1109–24.
- [67] Larsen U, Pierobon L, Haglind F, Gabrielli C. Design and optimisation of organic Rankine cycles for waste heat recovery in marine applications using the principles of natural selection. *Energy* 2013;55:803–12.
- [68] Bellolio Domke SA, Lemort V, Rigo P. Organic Rankine cycles systems for waste heat recovery in marine applications, in: *International conference on shipping in changing climates*, Glasgow, UK, 2015, pp. 1–11.
- [69] Sua'ez de la Fuente S, Greig AR. Making shipping greener: comparative study between organic fluids and water for Rankine cycle waste heat recovery. *J Mar Eng Technol* 2015;14(2):70–84.
- [70] Sundel T. Rankine cycle device having multiple turbo-generators, patent US7665304 B2; 2010.
- [71] Copper Development Association. *Materials for seawater pipeline systems*, Tech. rep. Copper Development Association; 1986.
- [72] De la Fuente SS, Larsen U, Pierobon L, Kærn MR, Haglind F, Greig A. Selection of cooling fluid for an organic Rankine cycle unit recovering heat on a container ship sailing in the Arctic region. *Energy* 2017;141:975–90.
- [73] Choi BC, Kim YM. Thermodynamic analysis of a dual loop heat recovery system with trilateral cycle applied to exhaust gases of internal combustion engine for propulsion of the 6800 TEU container ship. *Energy* 2013;58:404–16.
- [74] Nielsen RF, Haglind F, Larsen U. Design and modeling of an advanced marine machinery system including waste heat recovery and removal of sulphur oxides. *Energy Convers Manag* 2014;85:687–93. [2014].
- [75] Deniz C. Thermodynamic and environmental analysis of low-grade waste heat recovery system for a ship power plant. *Int J Energy Sci* 2015;5(1):23–34.
- [76] Song J, Li Y, Gu CW, Zhang L. Thermodynamic analysis and performance optimization of an ORC (organic Rankine Cycle) system for multi-strand waste heat sources in petroleum refining industry. *Energy* 2014;82:976–85.
- [77] Faisal A, Nugroho TF. Technical analysis of organic Rankine cycle system using low-temperature source to generate electricity in ship. *J Tek ITS* 2016;5(2):B394–9.
- [78] Yang MH, Yeh RH. Analyzing the optimization of an organic Rankine cycle system for recovering waste heat from a large marine engine containing a cooling water system. *Energy Convers Manag* 2014;88:999–1010.
- [79] Andreasen J, Larsen U, Haglind F. Design of organic Rankine cycles using a non-conventional optimization approach, in: *Proceedings of the 28th International Conference on Efficiency, Cost, Optimization, Simulation and Environmental Impact of Energy Systems*, Pau, France, 1–12.
- [80] Lode B. Organic Rankine cycles for waste heat recovery from diesel engines, Tech. rep. The Ship Research Institute of Norway; 1982.
- [81] Grljus'ić M, Medica V, Radica G. Calculation of efficiencies of a ship power plant operating with waste heat recovery through combined heat and power production. *Energies* 2015;8:4273–99.
- [82] Larsen U, Sigthorsson O, Haglind F. A comparison of advanced heat recovery power cycles in a combined cycle for large ships, in: *Proceedings of the 26th International Conference on Efficiency, Cost, Optimization, Simulation and Environmental Impact of Energy Systems*, Guilin, China, 2013, pp. 1–13.
- [83] Koroglu TS, Sogut OS. Advanced exergy analysis of an organic Rankine cycle waste heat recovery system of a marine power plant. *J Therm Eng* 2016;3(2):1136–48.
- [84] Hountalas DT, Katsanos C, Mavropoulos GC. Efficiency improvement of large scale 2-stroke diesel engines through the recovery of exhaust gas using a Rankine cycle. *Procedia-Social Behav Sci* 2012;48:1444–53.
- [85] Soffiati M, Frangopoulos CA, Manente G, Rech S, Lazzaretto A. Design optimization of ORC systems for waste heat recovery on board a LNG carrier. *Energy Convers Manag* 2015;92:523–34.
- [86] Kalikatzarakis M, Frangopoulos CA. Multi-criteria selection and thermo-economic optimization of an organic Rankine cycle system for a marine application. *Int J Thermodyn* 2015;18(2):133–41.
- [87] Mondejar ME, Ahlgren F, Thern M, Genrup M. Quasi-steady state simulation of an organic Rankine cycle for waste heat recovery in a passenger vessel. *Appl Energy* 2016(1–2):1–12.
- [88] Girgin I, Ezgi C. Design and thermodynamic and thermoeconomic analysis of an organic Rankine cycle for naval surface ship applications. *Energy Convers Manag* 2017;148:623–34.
- [89] Suárez de la Fuente S, Roberge D, Greig AR. Safety and CO<sub>2</sub> emissions: Implications of using organic fluids in a ship's waste heat recovery system, *Marine Policy*, 7, 5, 2017, 191–2017203).
- [90] Öhman H, Lundqvist P. Comparison and analysis of performance using low temperature power cycles. *Appl Therm Eng* 2013;52(1):160–9.
- [91] Yang MH. Payback period investigation of the organic Rankine cycle with mixed working fluids to recover waste heat from the exhaust gas of a large marine diesel engine. *Energy Convers Manag* 2018;162:189–202. [Apr 15].
- [92] Ozone Secretariat UNEP. Montreal protocol on substances that deplete the ozone layer, Tech. rep. Ozone Secretariat UNEP; 1987.
- [93] The European Union. Regulation on fluorinated greenhouse gases and repealing Regulation (EC), Tech. rep. The European Union; 2014.
- [94] The International Maritime Organisation. Revised MARPOL Annex VI - regulation 12 - Ozone Depleting Substances, Tech. Rep. June. The International Maritime Organisation; 2010.
- [95] The International Maritime Organisation. International convention for the safety of life at sea (SOLAS), Tech. rep. The International Maritime Organisation; 1974.
- [96] Guidelines on alternative design and arrangements for fire safety, Tech. rep., The International Maritime Organisation; 2001.
- [97] Rules and Regulations for the classification of ships. *Lloyd's Register*; 2017.
- [98] McLinden MO, Kazakov AF, Steven Brown J, Domanski PA. A thermodynamic analysis of refrigerants: possibilities and tradeoffs for low-GWP refrigerants. *Int J Refrig* 2014;38(1):80–92.
- [99] Liu W, Meinl D, Wieland C, Spliethoff H. Investigation of hydrofluoroolefins as potential working fluids in organic Rankine cycle for geothermal power generation. *Energy* 2014;67:106–16.
- [100] Kontomaris KK. Novel organic Rankine cycle working fluids for improved ship fuel efficiency: DR-2 (HFO-1336mzz(Z)) and DR-40a, in: *Proceedings of the International Conference on Energy and Environment in Ships*, Athens, Greece, 1–8; 2015.
- [101] Papadopoulos A, Stijepovic M, Linke P. On the systematic design and selection of optimal working fluids for organic Rankine cycles. *Appl Therm Eng* 2010;30(6–7):760–9.
- [102] Lecompte S, Huisseune H, van den Broek M, De Schampheleire S, De Paeppe M. Part load based thermo-economic optimization of the Organic Rankine Cycle (ORC) applied to a combined heat and power (CHP) system. *Appl Energy* 2013;111:871–81.
- [103] Pierobon L, Nguyen TV, Larsen U, Haglind F, Elmegaard B. Multi-objective optimization of organic Rankine cycles for waste heat recovery: application in an offshore platform. *Energy* 2013;58(0):538–49.
- [104] Sarkar J, Bhattacharyya S. Potential of organic Rankine cycle technology in India: working fluid selection and feasibility study. *Energy* 2015;90:1618–25.
- [105] MAN Diesel & Turbo. *Soot Deposits and Fires in Exhaust Gas Boilers*, Tech. rep. MAN Diesel & Turbo; 2015.
- [106] Brady M. Design aspects of once through systems for heat recovery steam generators for base load and cyclic operation. *Mater High Temp* 2001;18(4):223–9.
- [107] Coulson J, Richardson J, Backhurst J, Coulson and Richardson's Chemical Engineering. *Chemical engineering*. Oxford, Great Britain: Butterworth-

- Heinemann; 1999. [ISBN: 9780750644440].
- [108] Shah RK, Sekulić DP. *Fundamentals of Heat Exchanger Design*. Hoboken, New Jersey: John Wiley & Sons, Inc; 2003. [ISBN: 9780471321712].
- [109] *Heatric Division of Meggitt UK*, <www.heatric.com>, [accessed 6 August 2015].
- [110] Angelino G, Gaia M, Macchi E. Design, construction and testing of a hermetically sealed 100 kW organic Rankine cycle engine for medium temperature (200–400 °C) heat recovery, Tech. rep. Bruxelles, Belgium: Commission of the European communities; 1985.
- [111] Alaez SLG, Bombarda P, Invernizzi CM, Iora P, Silva P. Evaluation of ORC modules performance adopting commercial plastic heat exchangers. *Appl Energy* 2015;154:882–90.
- [112] Finney KA. Ocean thermal energy conversion. *Guelph Eng J* 2008;1(1):17–23.
- [113] Cho SY, Cho CH. An experimental study on the organic Rankine cycle to determine as to how efficiently utilize fluctuating thermal energy. *Renew Energy* 2015;80:73–9.
- [114] Kang SH. Design and experimental study of ORC (organic Rankine cycle) and radial turbine using R245fa working fluid. *Energy* 2012;41(1):514–24.
- [115] Wu Z, Pan D, Gao N, Zhu T, Xie F. Experimental testing and numerical simulation of scroll expander in a small scale organic Rankine cycle system. *Appl Therm Eng* 2015;87:529–37.
- [116] Balje O. A study on design criteria and matching of turbomachines: Part a: similarity relations and design criteria of turbines. *J Eng Power* 1962;84(1):83–102.
- [117] Csanady GT. *Theory of Turbomachines*. McGraw-Hill; 1964. [ASIN: B0007EE8UC].
- [118] Barber-Nichols, <www.barber-nichols.com>, [accessed 6 August 2015].
- [119] Boyce MP. *Gas turbine engineering handbook*. Oxford, Great Britain: Butterworth-Heinemann; 2012. [ISBN: 9780123838421].
- [120] Saravanamuttoo H, Rogers GF, Cohen H. *Gas turbine theory*. Dorset, Great Britain: Pearson Education; 2001. [ISBN: 9780132224376].
- [121] Astolfi M, Romano MC, Bombarda P, Macchi E. Binary ORC (Organic Rankine Cycles) power plants for the exploitation of medium–low temperature geothermal sources—Part B: techno-economic optimization. *Energy* 2014;66(0):435–46.
- [122] Hawkins LA, Zhu L, Blumberg EJ. Development of a 125 kW AMB expander/generator for waste heat recovery. *ASME J Gas Eng Turbines Power* 2011;133(7):1–6.
- [123] Borsukiewicz-Gozdur A. Pumping work in the organic Rankine cycle. *Appl Therm Eng* 2013;51(1):781–6.
- [124] Karassik IJ, Messina JP, Cooper P, Heald CC, Krutzsch W, Hosangadi A, Kittredge C, Fraser WH, Marscher WD, Boyadjis PA, et al. *Pump handbook 3*. New York: McGraw-Hill; 1986.
- [125] Mirmobin P, Sellers C. Advanced controls of organic Rankine cycle for highly transient fluctuations during initial startup, in: *Proceedings of the 3rd International Seminar on ORC Power Systems*, Bruxelles, Belgium, 1–9.
- [126] Vetter C, Wiemer HJ. Dynamic simulation of a supercritical ORC using low-temperature geothermal heat, in: *Proceedings of the World Geothermal Congress 2015*, Melbourne, Australia, 1–11; 2015.
- [127] Gabbriellini R. A novel design approach for small scale low enthalpy binary geothermal power plants. *Energy Convers Manag* 2012;64:263–72.
- [128] Pierobon L, Nguyen TV, Mazzucco A, Larsen U, Haglind F. Part-load performance of a wet indirectly fired gas turbine integrated with an organic Rankine cycle turbogenerator. *Energies* 2014;7(12):8294–316.
- [129] Casartelli D, Binotti M, Silva P, Macchi E, Roccaro E, Passera T. Power block off-design control strategies for indirect solar ORC cycles. *Energy Procedia* 2015;69:1220–30.
- [130] Pierobon L, Benato A, Scolari E, Haglind F, Stoppato A. Waste heat recovery technologies for offshore platforms. *Appl Energy* 2014;136:228–41.
- [131] Pierobon L, Casati E, Casella F, Haglind F, Colonna P. Design methodology for flexible energy conversion systems accounting for dynamic performance. *Energy* 2014;68:667–79.
- [132] Kopecek H, Ast G, Frey T, Huck P. Turbine inlet condition controlled organic Rankine cycle, patent US8813498 B2; 2010.
- [133] Wittchow E. *Fossil Energy*, Springer Berlin Heidelberg, ISBN: 9783540456414; 2002.
- [134] Horst TA, Tegethoff W, Eilts P, Koehler J. Prediction of dynamic Rankine Cycle waste heat recovery performance and fuel saving potential in passenger car applications considering interactions with vehicles energy management. *Energy Convers Manag* 2014;78:438–51.
- [135] Casella F, Mathijssen T, Colonna P, van Buijtenen J. Dynamic modeling of ORC power systems. *ASME J Gas Eng Turbines Power* 2012;135:1–12.
- [136] Quoilin S, Aumann R, Grill A, Schuster A, Lemort V, Spliethoff H. Dynamic modeling and optimal control strategy of waste heat recovery organic Rankine cycles. *Appl Energy* 2011;88(6):2183–90.
- [137] Van Horne JC, Wachowicz JM. *Fundamentals of Financial Management*. Harlow, Great Britain: Pearson Education; 2008. [ISBN: 9780273713630].
- [138] Gratsos G, Zachariadis P. Life cycle cost of maintaining the effectiveness of a ship's structure and environmental impact of ship design parameters: an update, Tech. rep. Hellenic chamber of shipping; 2009.
- [139] National Institute of Statistics and Economic Studies, <www.bdm.insee.fr>, [accessed 24 August 2016].
- [140] Lemmens S. Cost engineering techniques and their applicability for cost estimation of organic Rankine cycle systems. *Energies* 2016;9(7):485.
- [141] MAN Diesel & Turbo. Project guides S80ME-C9.2, Tech. rep. MAN Diesel & Turbo; 2016.
- [142] MAN Diesel & Turbo. Emission project guide, Tech. rep. MAN Diesel & Turbo; 2015.
- [143] Teng H, Regner G, Cowland C. Waste heat recovery of heavy-duty diesel engines by organic Rankine cycle part I: hybrid energy system of diesel and Rankine engines, Tech. rep., SAE Technical Paper; 2007.
- [144] Lang W, Colonna P, Almbauer R. Assessment of waste heat recovery from a heavy-duty truck engine by means of an ORC turbogenerator. *ASME J. Gas Eng. Turbines Power* 135. 2013. p. 042313.
- [145] MAN Diesel & Turbo. Service experience, Tech. rep. MAN Diesel & Turbo; 2014.
- [146] DNV-GL, <www.dnvgl.com/maritime/ing/ships.html>, [accessed 11 July 2016].
- [147] Jimenez Espadafor F, Torres Garcia M, Becerra Villanueva J, Moreno Gutierrez J. The viability of pure vegetable oil as an alternative fuel for large ships. *Transp Res Part D: Transp Environ* 2009;14(7):461–9.
- [148] McGill R, Remley W, Winther K. Alternative fuels for marine applications: a report from the IEA advanced motor Fuels implementing agreement. *Int Energy Agency* 2013.
- [149] Geng P, Cao E, Tan Q, Wei L. Effects of alternative fuels on the combustion characteristics and emission products from diesel engines: a review. *Renew Sustain Energy Rev* 2017;71:523–34.
- [150] Ellis J, Tanneberger K. Study on the use of ethyl and methyl alcohol as alternative fuels in shipping. *European Maritime Safety Agency*; 2015.
- [151] Deniz C, Zincir B. Environmental and economical assessment of alternative marine fuels. *J Clean Prod* 2016;113:438–49.
- [152] Semelsberger TA, Borup RL, Greene HL. Dimethyl ether (DME) as an alternative fuel. *J Power Sources* 2006;156(2):497–511.
- [153] Baldasso E, Andreasen JG, Meroni A, Haglind F. Performance analysis of different organic Rankine cycle configurations on board liquefied natural gas-fuelled vessels. In *ECOS 2017 In: Proceedings of the 30th International Conference on Efficiency, Cost, Optimization, Simulation and Environmental Impact of Energy Systems*; 2017.
- [154] Sung T, Yoon SY, Kim KC. A dual loop organic Rankine cycle utilizing boil-off gas in LNG tanks and exhaust of marine engine, in: *Proceedings of the 3rd International Seminar on ORC Power Systems*, Bruxelles, Belgium, 1–8.
- [155] Mitsubishi Heavy Industries. Hydrocurrent™ organic Rankine cycle module 125EJW - Compact and high-performance waste heat recovery system utilizing low temperature heat source, Tech. rep. Mitsubishi Heavy Industries Marine Machinery & Engine Co., Ltd.; 2015.
- [156] ENERTIME. ENERTIME has received a funding from the European Union under the H2020 program to implement its ORC technology in large ships, Tech. rep. ENERTIME; 2015.
- [157] ENERTIME. Energy efficiency for diesel power plants, Tech. rep. ENERTIME; 2015.
- [158] Mercator Media, <www.motorship.com/news101/engines-and-propulsion/organic-Rankine-cycle-heat-recovery-technology-read> [accessed 6 August 2015].
- [159] Kobe Steel, <www.kobelco.co.jp>, [accessed 6 August 2015].
- [160] Johansson MT, So'nderstro'm M. Electricity generation from low-temperature industrial excess heat -An opportunity for the steel industry. *Energy Effic* 2014;7(2):203–15.
- [161] MAN Diesel & Turbo. Thermo efficiency system for reduction of fuel consumption and CO<sub>2</sub> emission, Tech. rep. MAN Diesel & Turbo; 2014.
- [162] European Marine Equipment Council. *Green ship technology book*. Bruxelles, Belgium: European Marine Equipment Council; 2009.
- [163] Mitsubishi Heavy Industries, <www.mhi-global.com/products/pdf/mers.pdf>, [accessed 6 August 2015].
- [164] Wartsila Corporation, [www.smm.bzi.pl/publikacje/Emissions-1.pdf](http://www.smm.bzi.pl/publikacje/Emissions-1.pdf), [accessed: 06 August 2015].
- [165] Dimopoulos G, Georgopoulou CA, Kakalis N. Modelling and optimisation of an integrated marine combined cycle system, in: *Proceedings of the 24th International Conference on Efficiency, Cost, Optimization, Simulation and Environmental Impact of Energy Systems*, Novi Sad, Serbia, 1283–1298.
- [166] Theotokatos G, Livanos G. Techno-economical analysis of single pressure exhaust gas waste heat recovery systems in marine propulsion plants. *Proc Inst Mech Eng, Part M: J Eng Marit Environ* 2012;227(2):83–97.
- [167] Hou Z, Vlaskos I, Fusstetter K, Kahi M, Neuenschwander P. New application fields for marine waste heat systems by analysing the main design parameters, in: *Proceedings of the 25th CIMAC World Congress*, Vienna, Austria, 1–15.
- [168] Jonsson M. *Advanced power cycles with mixtures as the working fluid Ph.D. Thesis Royal Institute of Technology*; 2003.
- [169] Bombarda P, Invernizzi C, Pietra C. Heat recovery from Diesel engines: a thermodynamic comparison between Kalina and ORC cycles. *Appl Therm Eng* 2010;30:212–9.
- [170] Becquin G, Freund S. Comparative performance of advanced power cycles for low-temperature heat sources, in: *Proceedings of the 25<sup>th</sup> International Conference on Efficiency, Cost, Optimization, Simulation and Environmental Impact of Energy Systems*, Perugia, Italy, 1–17.
- [171] Climeon, <http://climeon.com/>, [accessed 6 August 2015].
- [172] Sarnacki WP, Wallace TT, Wlodkowski PA. Increasing the diesel and Brayton cycle efficiency with thermoelectric materials, in: *Proceedings of ASME International Mechanical Engineering Congress and Exposition*, Vancouver, British Columbia, 393–401; 2010.
- [173] Shu G, Zhao J, Tian H, Wei H, Liang X, Yu G, Liu L. Parametric and exergetic analysis of waste heat recovery system based on thermoelectric generator and organic rankine cycle utilizing R123. *Energy* 2012;45:806–16.
- [174] Loupis M, Papanikolaou N, Prousalidis J. Fuel consumption reduction in marine power systems through thermoelectric energy recovery, in: *Proceedings of the 2nd International MARINELIVE Conference on All Electric Ship*, Athens, Greece, 1–7.
- [175] Smith IK. Development of the trilateral flash cycle system: Part 1: Fundamental considerations. *Proc Inst Mech Eng, Part A: J Power Energy* 1993;207(3):179–94.
- [176] Brown BW, Mines GL. Flowsheet simulation of the trilateral cycle. *Geotherm Resour Counc Trans* 1998;22:373–7.

- [177] Lecompte S, van den Broek M, De Paepe M. Thermodynamic analysis of the partially evaporating trilateral cycle, in: Proceedings of the 2nd International Seminar on ORC Power Systems, Rotterdam, Netherlands, 1–4.
- [178] Zamfirescu C, Dincer I. Thermodynamic analysis of a novel ammoniawater trilateral Rankine cycle. *Thermochim Acta* 2008;477(1–2):7–15.
- [179] Prater DM. A dual cycle reciprocating engine, Tech. rep., SAE Technical Paper; 2000.
- [180] The New York Times, New British engine - surpasses diesel, [accessed 6 August 2015].
- [181] Conklin JC, Szybist JP. A highly efficient six-stroke internal combustion engine cycle with water injection for in-cylinder exhaust heat recovery. *Energy* 2010;35(4):1658–64.
- [182] Larsen U, Wronski J, Andreasen JG, Baldi F, Pierobon L. Expansion of organic Rankine cycle working fluid in a cylinder of a low-speed two-stroke ship engine. *Energy* 2017;119:1212–20.
- [183] Bivens DB, Minor BH. Fluoroethers and other next generation fluids. *Int J Refrig* 1998;21(7):567–76.
- [184] Linde Gases Division. Guide to updated EU F-gas regulation (517/2014), Tech. Rep. July, Linde Gases Division.