



CHALMERS
UNIVERSITY OF TECHNOLOGY

Vibrotactile Thresholds on the Mastoid and Forehead Position of Deaf Patients Using Radioear B71 and B81

Downloaded from: <https://research.chalmers.se>, 2026-04-05 02:56 UTC

Citation for the original published paper (version of record):

Fredén Jansson, K., Håkansson, B., Reinfeldt, S. et al (2017). Vibrotactile Thresholds on the Mastoid and Forehead Position of Deaf Patients Using Radioear B71 and B81. *Ear and Hearing*, 38(6): 714-723. <http://dx.doi.org/10.1097/AUD.0000000000000456>

N.B. When citing this work, cite the original published paper.

Vibrotactile Thresholds on the Mastoid and Forehead Position of Deaf Patients Using Radioear B71 and B81

Karl-Johan Fredén Jansson,¹ Bo Håkansson,¹ Sabine Reinfeldt,¹
 Laura Fröhlich,² and Torsten Rahne²

Objectives: The main objective of this study was to measure the vibrotactile thresholds on the mastoid process and forehead positions using patients with bilateral deafness and to compare the results from the two bone conduction vibrators Radioear B71 and B81.

Design: There is a possibility that the vibrotactile sensation on the skin makes it difficult to discriminate between sound and vibration. The risk is highest for patients who have bone conduction hearing thresholds in proximity to or worse than their vibrotactile thresholds. All measurements were performed similar to regular bone conduction threshold testing using an audiometer-driven bone conduction vibrator and pulsed warble tones, but the patients were instructed to respond only when feeling vibrations of the bone conduction vibrator instead of when hearing sound. Both the posterior forehead position and the mastoid process position on the temporal bone were tested for comparative reasons. In total, 16 patients participated in the study, 31% females and 69% males of age 29 to 77 years. All subjects were cochlear implant recipients, either uni- or bilaterally implanted. They were selected based on their audiogram data showing unmeasurable unaided hearing.

Results: The force level at which the vibrotactile thresholds were reached, increased with frequency from 125 up to 500 Hz, but remained constant for higher frequencies up to 2 kHz. A statistically significant difference was found between the 2 devices at 125 Hz at both the mastoid process and forehead position, where the vibrotactile threshold seem to be more sensitive for B71, possibly due to contribution of distortion components. There was no statistically significant difference in vibrotactile thresholds between the mastoid process and forehead position in absolute values (force level in dB re 1 μ N), but in terms of hearing levels (dB HL) there was an average difference of 10 and 9 dB for B71 and B81, respectively.

Conclusions: The results indicate that the vibrotactile thresholds can be confounded with bone conduction hearing thresholds measurements up to 500 Hz when using a standard audiometer and in particular when measuring on the forehead position.

Key words: Audiology, Bone conduction audiometry, Electromagnetic transducer, Vibrotactile thresholds, Electro-acoustics.

(*Ear & Hearing* 2017;38:714–723)

INTRODUCTION

Patients who are suffering from severe uni- or bilateral sensorineural hearing loss are sometimes rehabilitated using cochlear implants (CIs) on either one or both ears. Commonly, they do not benefit enough from using neither conventional air

(AC) nor bone conduction (BC) devices. Their hearing ability is sometimes impaired to the extent that both AC and BC hearing thresholds are worse than the maximum output level of the audiometer being used in the test. When those patients become CI recipients, their aided hearing is improved, but their residual hearing usually deteriorates due to the invasive CI surgery (Raveh et al. 2014; Zanetti et al. 2015).

Sensorineural hearing loss is measured by BC audiometry using a BC vibrator. However, when a BC vibrator generates high output levels, and especially at low frequencies, the patient may feel the vibrations rather than hear the sound due to the vibrotactile sensation in the skin. It is worth noting that “tactile” is generally used in the literature to describe the feeling of touch, but in this study, “vibrotactile” is instead used in order to refer to the ability to feel vibration, and should not be confused with the detection of the static pressure against the skin. Moreover, the vibrotactile sensation is a phenomenon confounded with bone conducted sound through the skin at frequencies where the BC and vibrotactile thresholds are likely to overlap (Boothroyd & Cawkwell 1970; Brinkmann & Richter 1983; International Organization for Standardization 8253-1 2010; Eichenauer et al. 2014). If the patient responds to a vibrotactile threshold during BC threshold testing at a frequency where the BC threshold is worse, there is a risk that the patient’s conductive hearing loss is overestimated. In a hearing aid fitting procedure, this can lead to a scenario where the patient gets a hearing aid which is not adjusted to the need, for example, giving too much gain at some frequencies. The vibrotactile sensation of the skin varies over the whole body and depends on several factors, such as frequency, age, and contact area (Verrillo 1963; Stuart et al. 2003; Wells et al. 2005; Ragert et al. 2008). The BC vibrators in this study have the same contact area of 1.75 cm² (Richter & Frank 1985; Fredén Jansson et al. 2015) and should therefore not cause any deviating results.

Another well-known reason for why it can be challenging to measure BC thresholds at low frequencies is because the commonly used Radioear B71 (Radioear Corporation, New Eagle, PA) generates high harmonic distortion at low frequencies (Dirks & Kamm 1975; Parving & Elbering 1982; Dolan & Moris 1990). It is also unknown if distortion affects the vibrotactile sensitivity. A more recently commercialized BC vibrator is the B81 which generates substantially lower distortion than B71 (Radioear B81 2017), because its motor unit is based on the balanced electromagnetic separation transducer principle (Håkansson 2003; Fredén Jansson et al. 2015). This makes it possible to investigate BC audiometry more accurately at low frequencies, for instance, the impact of vibrotactile thresholds, which is investigated in this study. For comparative reasons, both the conventional B71 and the new B81 are used for the measurements in this study.

It is common to position the BC vibrator on the mastoid process position behind the ear, but also on the posterior forehead position at some clinics (International Organization for

¹Department of Signals and Systems, Chalmers University of Technology, Göteborg, Sweden; and ²Department of Otorhinolaryngology, Head and Neck Surgery University Hospital, Halle (Saale), Germany.

Copyright © 2017 The Author(s). *Ear & Hearing* is published on behalf of the American Auditory Society, by Wolters Kluwer Health, Inc. This is an open-access article distributed under the terms of the Creative Commons Attribution-Non Commercial-No Derivatives License 4.0 (CCBY-NC-ND), where it is permissible to download and share the work provided it is properly cited. The work cannot be changed in any way or used commercially without permission from the journal.

Standardization 389-3 2016). Therefore, the forehead position was included as well, with the hypothesis that one of the two positions is more advantageous at certain frequencies when it comes to avoid measuring vibrotactile thresholds.

It was mentioned in a study by Eichenauer et al. (2014) that it is important to investigate if an audiometric BC vibrator is more likely to be limited by the vibrotactile sensitivity at low frequencies rather than distortion or maximum input voltage. If there are frequencies where the vibrotactile thresholds are reached at lower hearing levels than the maximum output level in dB HL that can be generated by the BC vibrators without exceeding a distortion of 6% (according to International Electrotechnical Commission 60645-1 2012), the vibrotactile threshold is the limiting factor. Therefore, distortion at the tactile thresholds is also investigated in this study.

Aim of Study

The aim of study is to measure the vibrotactile thresholds at the audiometric frequencies from 125 to 2000 Hz and to compare the results between one of the most commonly used audiometric BC vibrators, the Radioear B71, and the new B81, as well as against the standardized requirements on distortion and maximum output of audiometers, specified in International Electrotechnical Commission 60645-1 (2012). Both the position on the mastoid process behind the ear, where the BC vibrator is normally attached during BC audiometry, and on the forehead are investigated. An age correlation analysis of the results was also performed.

MATERIALS AND METHODS

This is a study where 16 patients who are suffering from severe bilateral sensorineural hearing loss have participated as tests

subjects, 31% were female and 69% male with mixed age from 29 to 77 years and the average age was 63 years. All test subjects were cochlear implant recipients, either uni-(62.5%) or bilaterally (37.5%) implanted. Ethical approval of the study was approved by the Ethical Review Board of the Martin-Luther-University-Halle-Wittenberg and all subjects signed a written informed consent.

Inclusion Criterion

It is important to ensure that the patients respond to vibrotactile sensation and not the perception of sound. Therefore, the inclusion criteria were to have unmeasurable AC and BC hearing thresholds.

Measurement Setup

Each patient was measured with two different types of BC vibrators; Radioear B71 and B81. Both were driven from the “free field speaker” output jack of a clinical audiometer SD-50 (Siemens AG, Erlangen, Germany). The reason for not using the regular BC vibrator output is because it is limited to the standard levels specified in International Electrotechnical Commission 60645-1 (2012) which are not high enough for reaching the vibrotactile thresholds at frequencies above 500 Hz (Boothroyd & Cawkwell 1970; Brinkmann & Richter 1983; International Organization for Standardization 8253-1 2010; Eichenauer et al. 2014). Every BC vibrator was calibrated on an artificial mastoid B&K 4930 (Brüel & Kjær Sound & Vibration Measurement A/S, Denmark) according to International Organization for Standardization 389-3 (2016). For further accuracy, the calibration was verified twice in different labs, using two different calibration services, and was found to deviate less than 1 dB for the audiometric frequencies, both before and after the study.

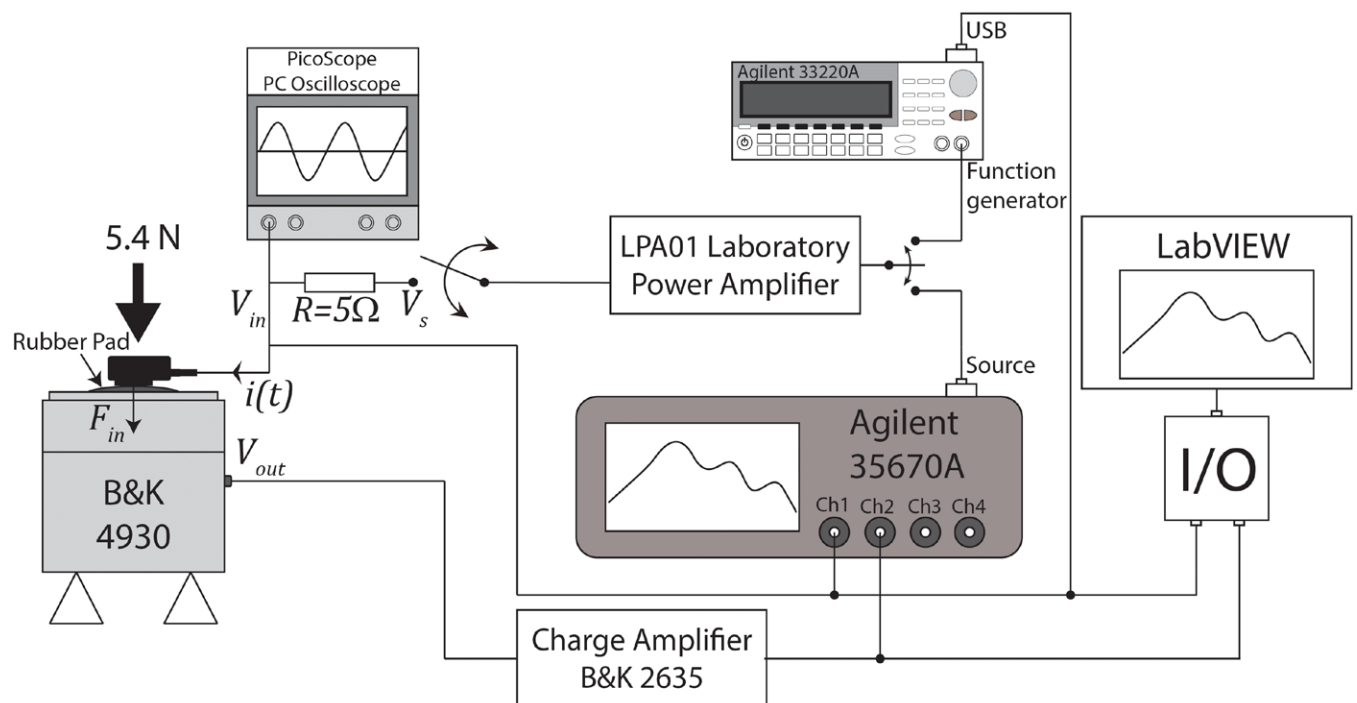

Fig. 1. The measurement setup of the instrumentation. The bone conduction vibrators were applied with a static force of 5.4 N to an artificial mastoid B&K 4930 followed by a charge amplifier B&K 2635. Signals were controlled and data collected using LabVIEW and a signal analyzer and an oscilloscope was monitoring and verifying the measurement. The LPA01 power amplifier was used to amplify the source signal and a switch was used to protect the bone conduction vibrator from power overload by shortening the operation time. A low power resistor “R” of 5 Ohms was used for overvoltage protection and to measure the current $i(t)$ to the bone conduction vibrator. The image is taken from Fredén Jansson et al. (2015).

The Vibrotactile Measurements

The measurements of vibrotactile thresholds were performed as regular BC threshold measurements, except that the patient was instructed to respond only when they felt the vibration from the BC vibrator and not when they heard the bone conducted sound. This was controlled by using CI patients with unmeasurable BC thresholds and they were asked after the measurement if they heard anything or not—the unanimous answer from all patients was “no.” The threshold determination method was descending/ascending with 1 dB increments from 5 dB below the response value until two similar values were obtained and the thresholds were measured in the order from the lowest to the highest frequency. In accordance to International Organization for Standardization 8253-1 (2010), the test tones were pulsed warble tones with a duration time of 1 sec to avoid a temperature increase of the BC vibrators from continuous tones. In a study by Burk and Wiley (2004), no significant differences were found between the hearing thresholds measured using continuous or pulsed stimuli, but listening to pulsed tones was perceived as an easier task, which supports the use of pulsed tones in this study. A temperature increase could introduce a calibration error if the frequency characteristics of the BC vibrators are temperature dependent. Measurements were carried out on both the forehead and the mastoid process part of the temporal bone behind the ear. With the free field output of the audiometer, vibrotactile thresholds were reached for the audiometric frequencies 0.125, 0.25, 0.75, 1.0, 1.5, and 2.0 kHz. Vibrotactile thresholds at higher frequencies were not measurable with the present setup and the highest measured vibrotactile threshold in BC audiometry found in the literature was 1 kHz (Martin & Wittich 1966; Boothroyd & Cawkwell 1970; Richter &

Brinkmann 1983; Eichenauer et al. 2014). However, Lamoré (1984) estimated the threshold at 2 kHz to 98 dB HL from measurements on the glabrous skin on the fingertip, and assuming that the hairy skin on the mastoid process had the same frequency dependence, but 14 dB less sensitive. The placement of the BC vibrators were therefore made carefully to maintain the same position and static force when changing BC vibrator. A steel spring headband P-3333 from Radioear (Radioear Corporation) was used to attach the BC vibrators to the head. The static force was not measured, but it was possible to see on the skin where the previous BC vibrator had been positioned. Furthermore, as anatomical structures and head size vary between patients, there will be variability in the static force between individuals when the deflection angle of the steel spring headband changes.

A statistical analysis of the results was performed using a paired two-tailed Student's *t* test ($p < 0.05$), since two dependent groups of means were compared at the time with the null-hypothesis that there is no difference between the two groups. The groups of means are dependent because the same patients have been used to test the outcome on both positions using both types of BC vibrators. A Bonferroni correction was made to handle multiple tests on the dependent groups. In total, 28 comparisons were performed; 2 positions, 2 devices, and at 7 frequencies. This resulted in a corrected *p* value of 0.0018.

Electro-Acoustic Performance

Both in the initial phase of the study and after measurements on all patients, the functionality of each BC vibrator was evaluated electro-acoustically by using the measurement setup shown in Figure 1. This was done by measuring total harmonic distortion

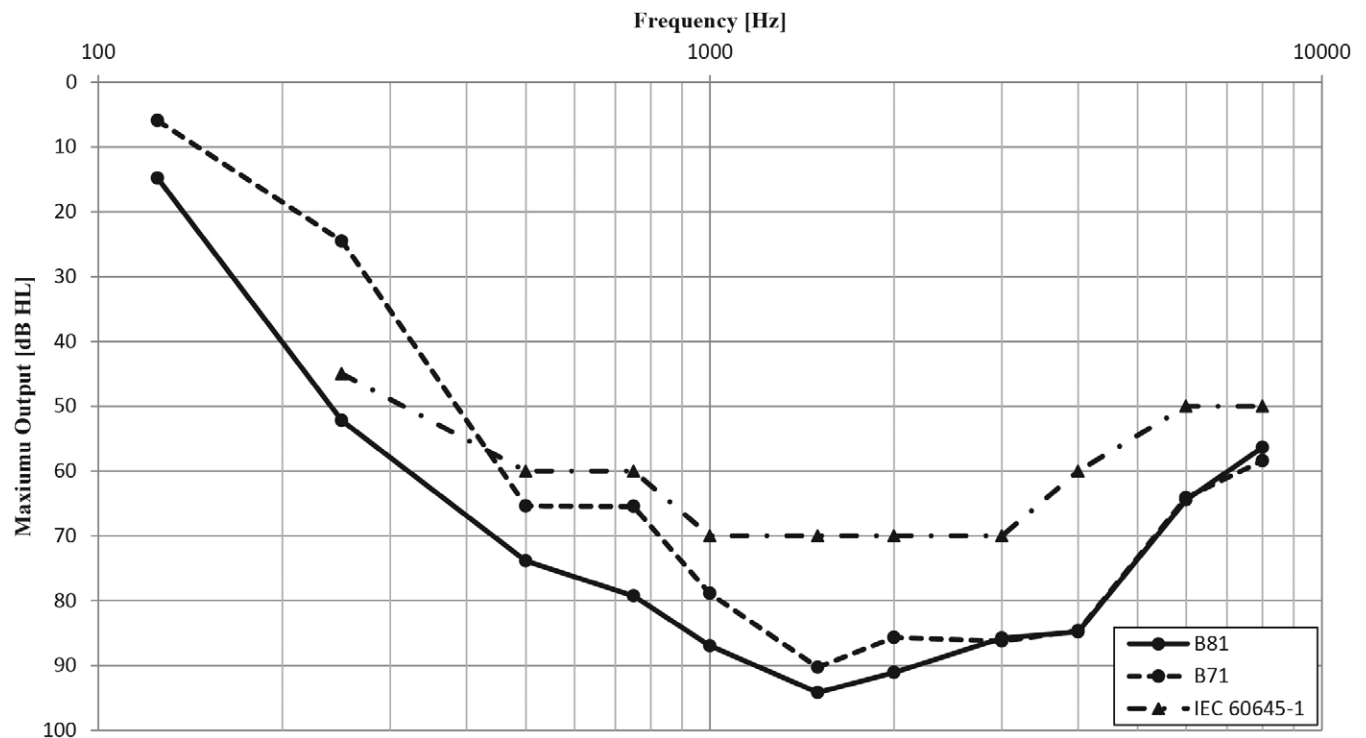

Fig. 2. The maximum output level in dB HL that can be generated by the B71 (black circles with dashed black line) and B81 (black circles with solid black line) in this study, respectively, without exceeding a total harmonic distortion of 6% or at a maximum input voltage of $6 V_{RMS}$, whichever comes first. The dashed line with triangles shows the minimum hearing level required in compliance with International Electrotechnical Commission 60645-1 (2012).

(THD), frequency response, and maximum output level in dB HL on an artificial mastoid, see the results in Figures 2–4, respectively.

Maximum Output Level

The maximum output levels that can be generated by most standard audiometers are specified as “type-1” in International Electrotechnical Commission 60645-1 (2012) and plotted as black triangles in Figure 2. At those hearing levels, the THD should be less than 6% (defined as the distortion of the standard BC vibrator B71 at 500 Hz and 60 dB HL). The maximum output levels that can be generated by the two types of BC vibrators in this study without exceeding 6% THD or an input voltage of $6 V_{\text{RMS}}$ (whichever comes first) are also shown in Figure 2. Both BC vibrators are above the standard requirements for frequencies at and above 500 Hz, while only the B81 is above at 250 Hz, and no standard requirement exists at 125 Hz where the B81 is 9 dB higher than B71.

Frequency Response

The frequency response was measured for each BC vibrator between 100 and 10,000 Hz at a constant input voltage of $1 V_{\text{RMS}}$ and the result can be seen in Figure 3.

Total Harmonic Distortion

The THD was measured for each BC vibrator for frequencies between 100 and 5000 Hz at a constant input voltage of $1 V_{\text{RMS}}$, see Figure 4. The maximum operation frequency of the artificial mastoid is 10 kHz, and THD was therefore not measured for frequencies above 5 kHz, because that would include second harmonics outside the range of the artificial mastoid. Even if it is possible to measure at higher frequencies, the artificial mastoid is not calibrated and valid above 10 kHz. As the frequency responses of the BC vibrators are very similar and they are driven with the same input voltage, the THD is assumed to be measured at the same output force level, which is important for an objective comparison.

RESULTS

Vibrotactile thresholds were detected at and below 1 kHz for all 16 test subjects and for both BC vibrators. With B71 on the

mastoid process and forehead positions, only 8 and 10 patients, respectively, responded to vibrotactile stimulation at 1.5 kHz, and 10 and 9 patients at 2 kHz, respectively. The corresponding number of patients for B81 was 7 and 14 at 1.5 kHz, and 9 and 10 at 2 kHz on mastoid process and forehead position, respectively. It was difficult to measure at those frequencies because the maximum output of the setup was reached before the thresholds were detected.

The average vibrotactile thresholds for B71 and B81 on the mastoid process and forehead position are shown in Figures 5, 6, respectively. Numerical values of the averages and SDs are given in Table 1.

When the vibrotactile thresholds were compared in terms of force levels in decibels relative to $1 \mu\text{N}$, only small differences between the two positions were found (Table 1; forehead versus mastoid process position). The average difference over all frequencies was 2 ± 1 and 2 ± 2 dB for B71 and B81, respectively, but the *t* test showed no statistically significant difference ($p < 0.0018$) at any frequency, see the statistical analysis of the results in Table 2. If any difference between the two positions is caused by hearing, it would have been approximately 8.5 dB higher (worse) on the forehead due to the difference in hearing sensitivity between the two positions (International Organization for Standardization 389-3 2016). This was not the case, which further indicates that the perception was vibrotactile rather than auditory. However, small differences can still be caused by variations in the measurement, based on test–retest variations seen when repeating a measurement at the same position and by changing between the BC vibrator positions. Other causes could be both psychological and practical factors, such as staying focused during the test or that the deflection of the steel spring headband is different for the two positions, causing a different static attachment force.

Between the two devices, there was a statistically significant difference at 125 Hz for both the mastoid process (5 dB) and the forehead (7 dB) position, which means that the vibrotactile sensation is more sensitive for B71 at that frequency, see

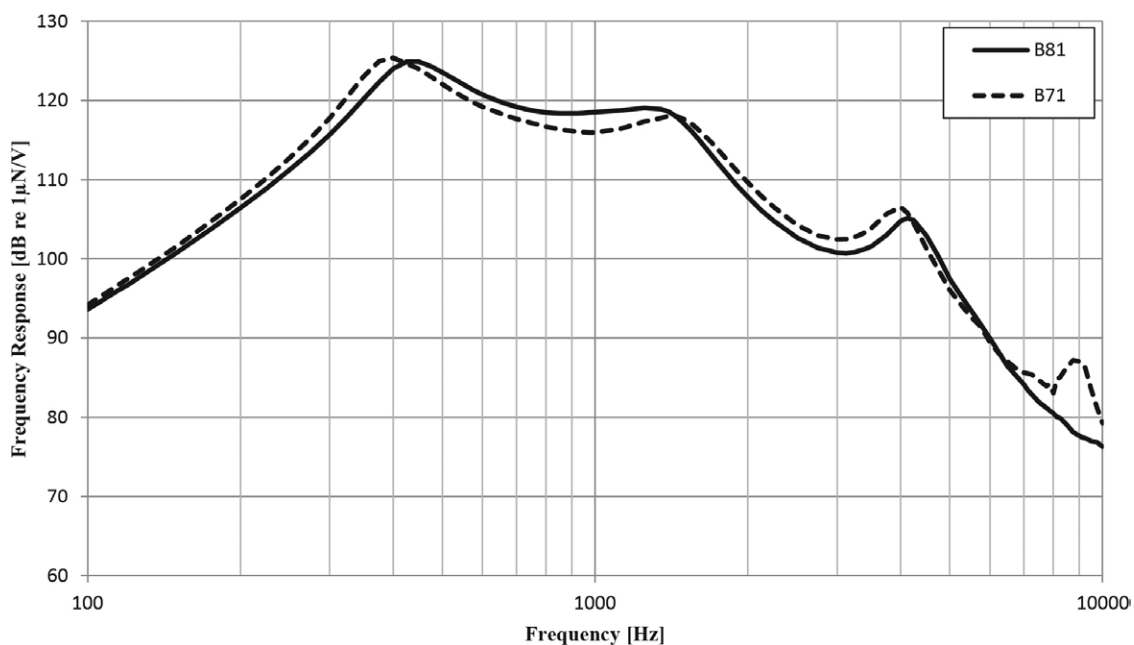

Fig. 3. The frequency responses for the B71 (dashed black line) and B81 (solid black line) used in the study measured at an input voltage of $1 V_{\text{RMS}}$ from 100 to 10,000 Hz. The magnitude is given in decibels relative to $1 \mu\text{N/V}$.

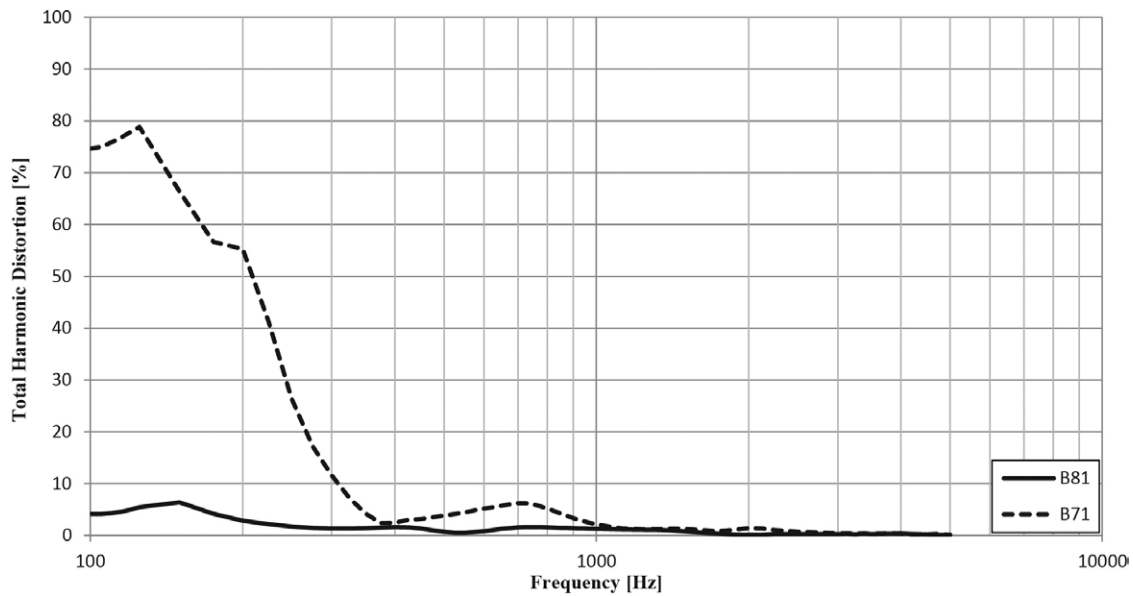

Fig. 4. The total harmonic distortion of the B71 (dashed black line) and B81 (solid black line) in the study when driven at a constant input voltage of $1 V_{RMS}$ from 100 to 5000 Hz.

Table 1. Both BC vibrators have the same surface area and were therefore expected to give similar results. If this difference is due to the high distortion of the B71, not only the fundamental frequency is stimulating the vibrotactile sensation but also there is an additional contribution to the vibrating force on the skin from higher order harmonics as well. This was further investigated by measuring the THD of the BC vibrators when they are generating the hearing levels corresponding to the average vibrotactile thresholds of the mastoid, see Figure 7 and the rightmost columns in Table 3. It was found that the THD at 125 Hz was 31.6% for B71 and only 6.3% for B81. Furthermore, it was found that the second harmonic was found 7 dB higher for B71 than B81 on the forehead, which is the same difference as between the tactile thresholds measured with the two devices. However, on the mastoid process, the difference between the second harmonics is 9 dB when the average tactile difference is 5 dB. One reason to why the difference agrees more on the

forehead might be that larger SDs were measured on the mastoid process position which indicates that the forehead position gives more stable results. Even though the distortion is higher for B71, these results do not fully support the claim that distortion is causing the difference in vibrotactile sensitivity at low frequencies, and is just an indication. For more definite results, a more substantial investigation needs to be performed by measuring the vibrotactile thresholds at different levels of distortion at low frequencies.

It was investigated how the vibrotactile thresholds vary with age among the test subjects, the results were analyzed using a linear regression calculation as a function of age. This resulted in slopes for every frequency with the unit decibels per years old for each frequency. The slopes for each frequency are given in Figure 8. From this analysis, it was found that the vibrotactile sensation deteriorates with age for frequencies up to 500 Hz at an average of 0.32 ± 0.14 dB per years older. Frequencies above

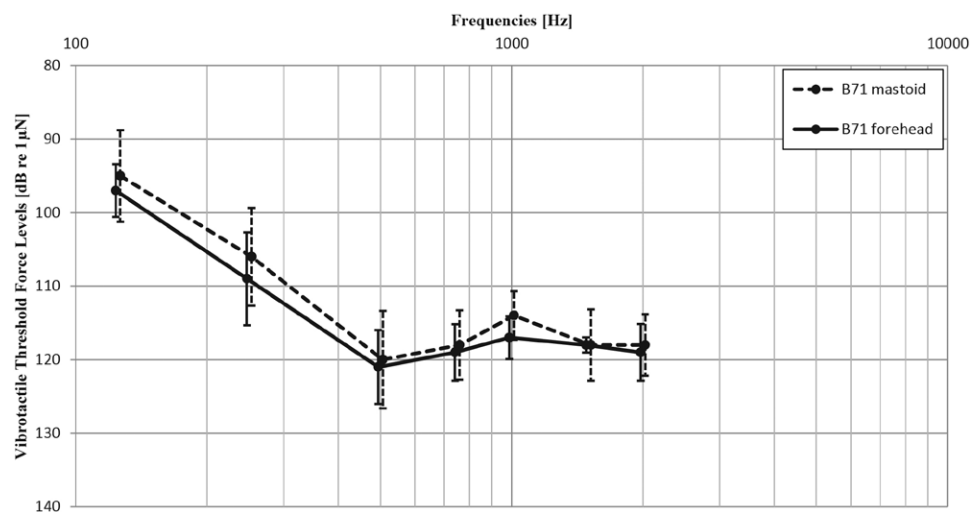

Fig. 5. The average vibrotactile thresholds on the mastoid process (black dots with dashed black line) and forehead position (black dots with solid black line) for the B71.

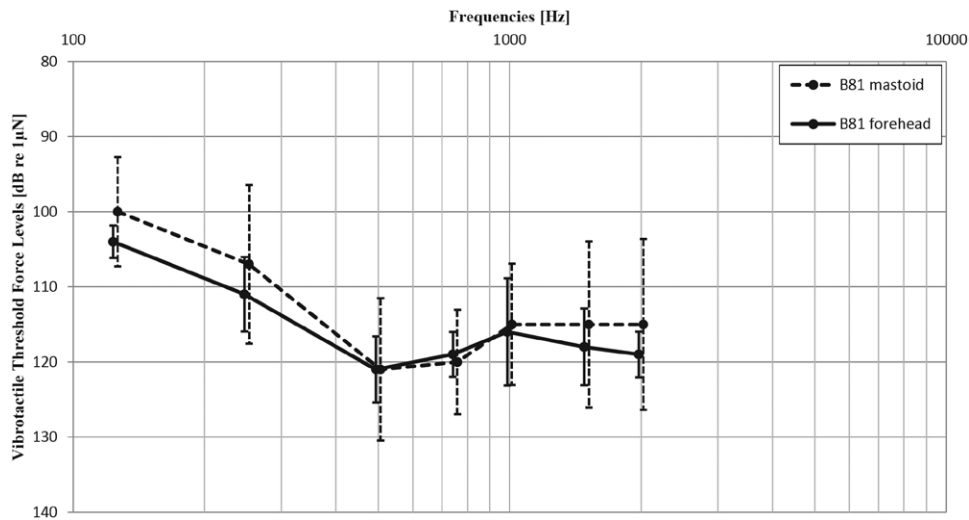

Fig. 6. The average vibrotactile thresholds on the mastoid process (black dots with dashed black line) and forehead position (black dots with solid black line) for B81.

1 kHz have been excluded from this analysis where vibrotactile thresholds were not reached for all 16 patients. It is well known that the vibrotactile sensitivity on the skin declines with increased age (Stuart et al. 2003; Wells et al. 2005; Ragert et al. 2008; Peters & Goldreich 2013). The maximum age difference of the patients included in this study was 48 years, which corresponds to a maximum loss of 15 dB (approximately 1/3 dB per year).

DISCUSSION

In the field of diagnostic audiology, it is more relevant to compare the thresholds in units of decibels in hearing level (dB HL) rather than force level (dB re 1µN). These values are illustrated as graphs in Figures 9, 10 and are given in Table 3. As specified in International Organization for Standardization 389-3 (2016), the reference equivalent threshold force level (RETFL) values for normal-hearing thresholds are different for the mastoid process and forehead position. Therefore, this difference should appear also in the vibrotactile thresholds, note the difference in Table 3. The average difference over all frequencies between the 2 positions when comparing the vibrotactile thresholds in units of dB HL was 10±3 dB for B71 and 9±4 dB for B81. A *t*-test confirmed this difference to be statistically

significant at all test frequencies for B71, but not at 125 and 2000 Hz for B81 where thresholds only from 6 patients could be compared, see Table 3. In clinical practice, the mastoid process position is more advantageous when it comes to avoid measuring vibrotactile thresholds during BC audiometry, because the thresholds on the forehead are reached at a lower hearing level than on the mastoid process position. Moreover, this is mainly due to the difference in hearing sensitivity in the two positions rather than the difference in vibrotactile sensitivity.

Regarding the clinical significance of these results, it can be seen in Figures 9, 10 that vibrotactile thresholds are within the output range of a type-1 audiometer (International Electrotechnical Commission 60645-1 2012) for frequencies up to 500 Hz, both on the forehead and mastoid process position. At higher frequencies, the vibrotactile thresholds are outside the audiometer range and should therefore not be detectable during standard BC audiometry. Audiometer type-3 has lower maximum output levels at and below 500 Hz (International Electrotechnical Commission 60645-1 2012) than type-1, which decreases the risk of measuring vibrotactile thresholds.

No masking of the ipsi- or contralateral ear was needed on the patients because they already had such a severe hearing loss on both ears. If measurements were to be done on normal-hearing subjects instead, masking would only be possible at the lower

TABLE 1. Numeric values of the average vibrotactile thresholds for B71 and B81, both for the mastoid and forehead position as well as the differences between both positions and devices

Frequency (Hz)	Vibrotactile Thresholds Mastoid (dB re 1µN)		Vibrotactile Thresholds Forehead (dB re 1µN)		Mastoid–Forehead Position (dB)		B81–B71 (dB)	
	B71	B81	B71	B81	B71	B81	Mastoid	Forehead
125	95±6	100±7	97±4	104±2	-2	-4	5*	7*
250	106±7	107±11	109±6	111±5	-3	-4	1	2
500	120±7	121±9	121±5	121±4	-1	0	1	0
750	118±5	120±7	119±4	119±3	-1	1	2	0
1000	114±3	115±8	117±3	116±7	-3	-1	1	-1
1500†	118±5	115±11	118±1	118±5	0	-3	-3	0
2000†	118±4	115±11	119±4	119±3	-1	-4	-3	0

*A statistically significant difference (*p* < 0.0018).

†Vibrotactile thresholds were not reached for all 16 patients at those frequencies.

TABLE 2. Result from the *t* test showing the *p* values when comparing the vibrotactile thresholds in force level units for the differences between both positions and devices

Frequency (Hz)	<i>p</i> Value: B81–B71 (dB)		<i>p</i> Value: Mastoid–Forehead (dB)	
	Mastoid	Forehead	B71	B81
125	0.001*	<0.001*	0.130	0.011
250	0.825	0.008	0.083	0.031
500	0.686	0.763	0.468	0.692
750	0.085	0.461	0.656	0.757
1000	0.892	0.539	0.014	0.148
1500†	0.778	0.517	0.235	0.740
2000†	0.487	0.803	0.354	0.376

*A statistically significant difference ($p < 0.0018$).

†Vibrotactile thresholds were not reached for all 16 patients at those frequencies.

frequencies. Masking at higher frequencies would require bone conducted sound and noise levels that would have been uncomfortably high for the test subject, who would therefore not be able to complete the measurement. Therefore, normal-hearing subjects were not used as test subjects in this study to avoid that problem. Although, it was found in a study by Nober (1964) that the presence of auditory masking will not affect the vibrotactile thresholds. When using CI patients, there are other things to consider, such as nerve loss in the skin around the scar from implantation. The BC vibrators were therefore never positioned on the scar. However, it was unknown if there were any surgery effects on the patients' cutaneous sensory perception around the scar that could introduce an uncertainty in the results due to damaged nerves and sensory cells. In future studies, it might be investigated how well these results apply to a population of normal-hearing subjects and the effect of using CI recipients. On the other hand, when comparing with literature, the obtained vibrotactile thresholds are at most frequencies within the range of those found in previous studies, see Table 4. The vibrotactile sensation was found to decrease with frequency, which means that patients with more profound hearing loss are likely to have BC thresholds in the proximity to their vibrotactile thresholds at the higher frequencies. None of the test subjects in this study reported any sound during the tests. However, some patients reported that it sometimes felt similar to feeling the vibrations

from their own voice while speaking. This might be caused by the fact that the vibrotactile sensation is perceived not only by sensation in the skin but also in other parts of the head. The vibrotactile thresholds obtained in the study by Eichenauer et al. (2014) were measured on normal-hearing subjects on the mastoid process position and bilaterally applied narrow band noise masking centered at the test frequency using nonoccluding earphones. They found vibrotactile thresholds that were reached at approximately 35 and 55 dB HL for 250 and 500 Hz, respectively, which is lower than the findings in this study. Furthermore, Nober (1964, 1970), who assumed the masking to not affect the threshold measurements, also measured lower (better) thresholds, see Table 4. The same masking method was used by Brinkmann and Richter (1983) and they found the thresholds 42 and 58 dB HL for 250 and 500 Hz, respectively. This is more similar to those measured in this study, but they measured only vibrotactile thresholds on the forehead and assumed those to be similar on the mastoid process position.

The only previously studies found of vibrotactile thresholds measured at 125 Hz was Brinkmann and Richter (1983) and Lamoré (1984) where the thresholds were 18 and 24 dB HL, respectively. In Lamoré, the threshold at 2 kHz was not measured, but estimated from measurements on the fingertip and assumed the threshold on the mastoid process to be 14 dB worse at that frequency. Interestingly, Martin and Wittich (1966)

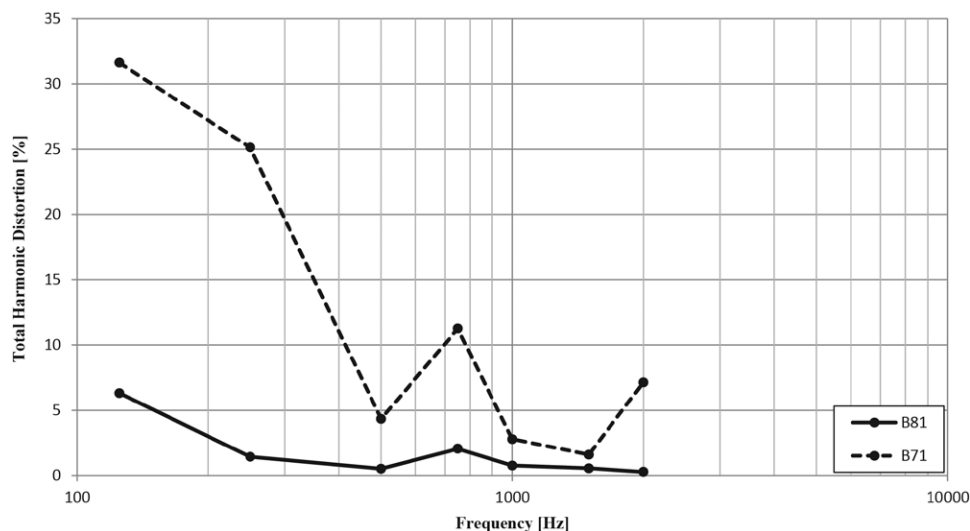

Fig. 7. The total harmonic distortion at the vibrotactile thresholds of B71 (circles with dashed black line) and B81 (circles with solid black line).

TABLE 3. The average vibrotactile thresholds expressed in the unit dB HL for B71 and B81, both for the mastoid and forehead position as well as the difference between the two positions

Frequency (Hz)	Vibrotactile Thresholds Mastoid (dB HL)		Vibrotactile Thresholds Forehead (dB HL)		Mastoid–Forehead (dB)		THD at the Mastoid Vibrotactile Thresholds (%)	
	B71	B81	B71	B81	B71	B81	B71	B81
125	13±6	17±7	8±4	14±2	5*	3	31.6	6.3
250	39±7	40±11	30±6	32±5	9*	8*	25.1	1.4
500	62±7	63±9	49±5	49±4	13*	14*	4.3	0.5
750	70±5	71±7	57±4	57±3	13*	13*	11.3	2.1
1000	72±3	72±8	66±3	66±7	6*	7*	2.8	0.8
1500†	81±5	79±11	70±1	70±5	11*	9*	1.6	0.6
2000†	87±4	84±11	76±4	76±3	11*	7	7.1	0.3

Numerical values of the total harmonic distortion of the two devices for the mastoid position when they generate the average vibrotactile threshold levels of the mastoid are also shown in the rightmost columns.

*A statistically significant difference ($p < 0.0018$).

†Vibrotactile thresholds were not reached for all 16 patients at those frequencies.

measured an average threshold of 80 dB HL on the forehead of 22 deaf children at 2 kHz, but non on the mastoid process because the audiometer was saturated. However, they mention that this value should be interpreted carefully, and at 250, 500, and 1000 Hz, they measured vibrotactile thresholds on the forehead of 40, 60, and 75 dB HL, respectively. Table 4 summarizes the vibrotactile thresholds on the mastoid process position from several studies since 1964 to 2014. The average vibrotactile thresholds on the mastoid process position of all studies in Table 4, including the findings in this study using B71 and B81, was 18 ± 5 dB HL at 125 Hz, 37 ± 6 dB HL at 250 Hz, 58 ± 6 dB HL at 500 Hz, and 76 ± 5 dB HL at 1000 Hz.

Another phenomenon that is known to affect BC audiometry is acoustically radiated noise from the B71 casing. However, this is a phenomenon that mainly occurs at high frequencies around 4 kHz (Frank & Crandell 1986) where vibrotactile thresholds are not an issue with B71. For further verification, the relative difference in acoustic radiation between B71 and B81 was measured at a vertical distance of 5 cm above the BC vibrators. They were driven on the artificial mastoid between 100 and 10,000 Hz at an input voltage of $1 V_{RMS}$, and no significant difference was observed between the devices. Other BC vibrators might be used to perform the vibrotactile threshold measurements.

However, one objective in this study was to compare B71 and B81, because they are very similar except for their performance at low frequencies, where B81 generates less distortion (Fredén Jansson et al. 2015). The Präcitronec KH70 (Grahnerc Präcitronec GmbH, Dresden, Germany) is another well-known BC vibrator, utilizing a head band that makes it difficult to attach on the forehead. Therefore, it would have been difficult to maintain the same static force as with the Radioear devices and was therefore not included in this study. Furthermore, KH70 is difficult to position on the mastoid process behind the ear without touching the pinna (Håkansson, 2003). Similar to regular BC audiometry, repositioning on the exact same position, differences in the static pressure of the two head bands and test–retest differences are factors that can cause differences in the results.

CONCLUSIONS

It was found that the vibrotactile thresholds on the mastoid process and forehead position of bilateral deaf patients can be detected during the BC audiometry for patients with more profound hearing losses and at frequencies up to 500 Hz. For higher frequencies, the risk for measuring vibrotactile thresholds is much lower and will most likely not influence hearing threshold accuracy. In summary:

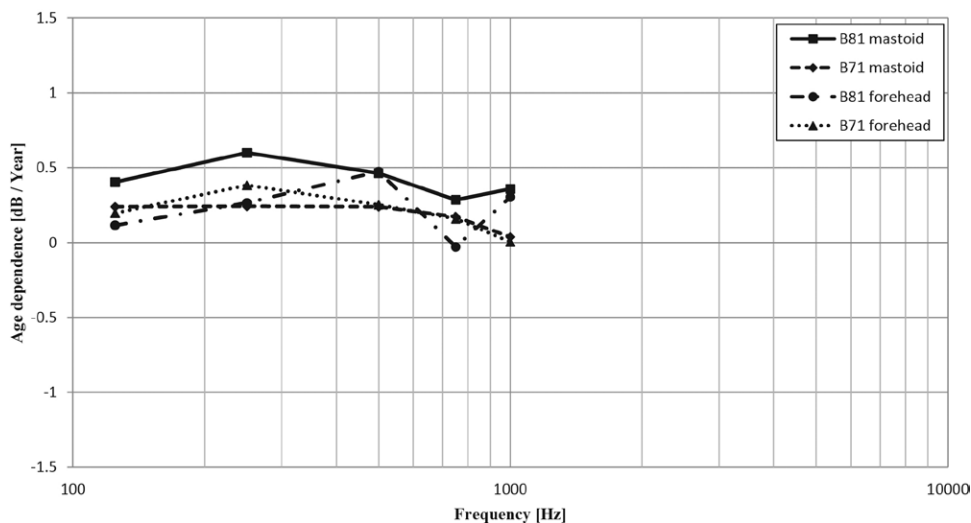

Fig. 8. Linear regression slopes of the vibrotactile thresholds as a function of age among the test subjects at each test frequency in decibels per years old.

Downloaded from http://journals.ww.com/ear-hearing by BndMfsePhKav1zEoum11QIN4a+kLhEZpshHe4XW0hC ywCX1AVhYQpIhQIH-D3D00DFRy7T7vSF14CF3V/C1y0abgqZXdtnwFKZB7wvs= on 08/03/2023

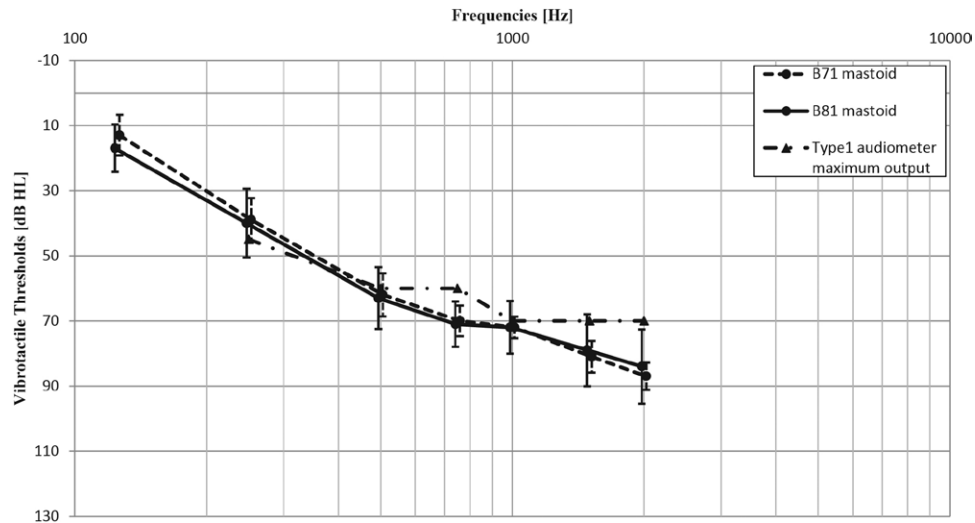

Fig. 9. The average vibrotactile thresholds on the mastoid process position for B71 (black dots with dashed black line) and B81 (black dots with solid black line) in the unit decibel hearing level (dB HL). The dashed line with triangles shows the maximum output levels in dB HL for a standard type-1 audiometer specified in International Electrotechnical Commission 60645-1 (2012).

- In terms of force level, the average difference over all frequencies between the mastoid process and forehead position was 2 ± 1 and 2 ± 2 dB for B71 and B81, respectively, but there was no statistically significant difference at any frequency.
- In terms of hearing level, the average difference over all frequencies between the mastoid process and forehead position was 10 ± 3 dB for B71 and 9 ± 4 dB for B81. Except for the frequencies 125 and 2000 Hz using B81, this difference was statistically significant for both B71 and B81 at all frequencies.
- There was a statistically significant difference between the two devices at 125 Hz for both the mastoid process and forehead position, where B71 was maximum 7 dB more sensitive to vibrotactile sensation than B81.
- The vibrotactile sensation was found to deteriorate with age for frequencies up to 500 Hz at an average of 0.32 ± 0.14 dB per years older.

The difference in vibrotactile thresholds at 125 Hz between the 2 devices is believed to be caused by the higher distortion of the B71 at that frequency, which was found to be 31.6%, and only 6.3% for B81. To fully conclude this, a more substantial investigation may be performed in the future by measuring the vibrotactile thresholds at different levels of distortion at low frequencies. To avoid any risk of measuring vibrotactile thresholds when performing BC audiometry using B71 and B81, the maximum output levels in dB HL for audiometers need to be decreased below the vibrotactile thresholds. However, this means that it would be impossible to measure BC thresholds at higher hearing levels for those frequencies. In future studies, the ability to discriminate between vibrotactile sensation and hearing should be investigated on normal-hearing subjects as well as the possibility to use masking for determine vibrotactile thresholds. The influence of the static force of the steel spring headband attaching the BC vibrators should also be

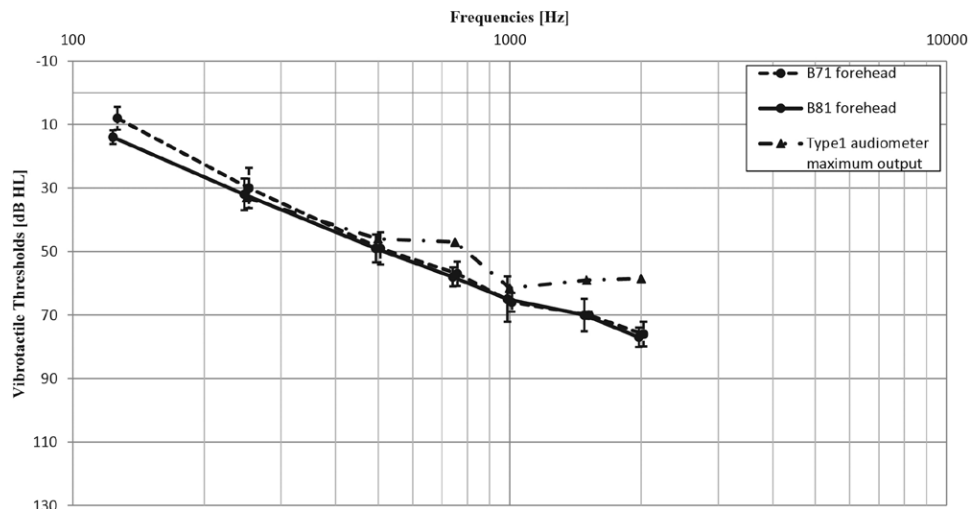

Fig. 10. The average vibrotactile thresholds on the forehead position for B71 (black dots with dashed black line) and B81 (black dots with solid black line) in the unit decibel hearing level (dB HL). The dashed line with triangles shows the maximum output levels for a standard type-1 audiometer specified in International Electrotechnical Commission 60645-1 (2012).

TABLE 4. Vibrotactile thresholds on the mastoid process position found in the literature from 1964 to 2014 and the values for B71 and B81 found in this study

Study and Device	Average Vibrotactile Thresholds on the Mastoid Position (dB HL)						
	125 Hz	250 Hz	500 Hz	750 Hz	1000 Hz	1500 Hz	2000 Hz
Nober (1964)*	—	25	50	—	—	—	—
Martin and Wittich (1966) B70A	—	45	70	—	80	—	—
Harbert and Young (1969)*	—	40	60	—	>60	—	—
Nober (1970)‡	—	32	51	—	—	—	—
Boothroyd and Cawkwell (1970)*	—	35	60	—	85	—	—
Brinkmann and Richter (1983) KH70	18	42	58	—	72	—	—
Lamoré (1984) B71	24	35	49	—	80	—	98†
Eichenauer et al. (2014) B71 & B81	—	35	55	—	75	—	—
International Organization for Standardization 8253-1 (2010)‡	—	40	60	—	70	—	—
This study B71	13	39	62	70	72	81‡	87‡
This study B81	17	40	63	71	72	79‡	84‡

*The bone vibrator being used in the study was not specified.

†The vibrotactile threshold was estimated from measurements on the fingertip at 2 kHz and not measured on the mastoid.

‡Vibrotactile thresholds were not reached for all 16 patients at those frequencies.

studied to find out how this static force affects the vibrotactile thresholds.

ACKNOWLEDGMENTS

This research was supported by HRF, the Hearing Research Foundation of Sweden. Bo Håkansson is the inventor of some balanced electromagnetic separation transducer patents which are licensed to the company manufacturing the B81 transducer.

The authors have no conflicts of interest to disclose.

Address for correspondence: Karl-Johan Fredén Jansson, Department of Signals and Systems, Chalmers University of Technology, 41296 Göteborg, Sweden. E-mail: karljohf@chalmers.se

Received June 16, 2016; accepted April 28, 2017.

REFERENCES

- Boothroyd, A., & Cawkwell, S. (1970). Vibrotactile thresholds in pure tone audiometry. *Acta Otolaryngol*, 69, 381–387.
- Brinkmann, K. & Richter, U. (1983). Determination of the normal threshold of hearing by bone conduction using different types of bone conduction vibrators. *J Audiol Technol*, 22, 62–85, 114–122.
- Burk, M. H., & Wiley, T. L. (2004). Continuous versus pulsed tones in audiometry. *Am J Audiol*, 13, 54–61.
- Dirks, D. & Kamm, C. (1975). Bone-vibrator measurements physical characteristics and behavioral thresholds. *J Speech Hear Res*, 18, 242–260.
- Dolan, T. G., & Morris, S. G. (1990). Administering audiometric speech tests via bone conduction: A comparison of transducers. *Ear Hear*, 11, 446–449.
- Eichenauer, A., Dillon, H., Clinch, B., et al. (2014). Effect of bone-conduction harmonic distortions on hearing thresholds. *J Acoust Soc Am*, 136, EL96–E102.
- Frank, T., & Crandell, C. C. (1986). Acoustic radiation produced by B-71, B-72, and KH 70 bone vibrators. *Ear Hear*, 7, 344–347.
- Fredén Jansson, K.-J., Håkansson, B., Johannsen, L., Tengstrand, T. (2015). Electro-acoustic performance of the new bone conduction vibrator Radioear B81 - a comparison with the conventional Radioear B71. *Int J Audiol*, 54:334–340.
- Håkansson, B. E. (2003). The balanced electromagnetic separation transducer a new bone conduction transducer. *J Acoust Soc Am*, 113, 818–825.
- Harbert, F., & Young, I. M. (1969). The low frequency air-bone gap in sensorineural deafness. *Ann Otol Rhinol Laryngol*, 78, 107–111.
- International Electrotechnical Commission 60645-1. (2012). *Electroacoustics – Audiometric equipment – Part 1: Equipment for pure-tone*

audiometry. Geneva: International Electrotechnical Commission; 2012-02.

International Organization for Standardization 389-3. (2016). *Acoustics – Reference zero for the calibration of audiometric equipment – Part 3: Reference equivalent threshold force levels for pure tones and bone conduction vibrators*. Geneva: International Organization for Standardization; 2016.

International Organization for Standardization 8253-1. (2010). *Acoustics – Audiometric test methods – Part 1: Basic pure tone air and bone conduction threshold audiometry*. Geneva: International Organization for Standardization; 1989-11-23.

Jansson, K. J., Håkansson, B., Johannsen, L., et al. (2015). Electro-acoustic performance of the new bone vibrator Radioear B81: A comparison with the conventional Radioear B71. *Int J Audiol*, 54, 334–340.

Lamoré, P. J. J. (1984). Vibrotactile thresholds for hairy skin and its transformation into equivalent bone-conduction loss for the mastoid. *Audiology*, 23:537–551.

Martin, F. N. & Wittich, W. W. (1966). A comparison of forehead and mastoid tactile bone conduction thresholds. *Eye Ear Nose Throat Mon*, 45:72.

Nober, E. H. (1964). Pseudoauditory bone-conduction thresholds. *J Speech Hear Disorders*, 29:469–476.

Nober, E. H. (1970). Cuticle air and bone conduction thresholds of the deaf. *Except Child*, 36:571–579.

Parving, A. & Elbering, C. (1982). High-pass masking in the classification of low-frequency hearing loss. *Scand Audiol*, 11:173–178.

Peters, R. M. & Goldreich, D. (2013). Tactile spatial acuity in childhood: Effects of age and fingertip size. *PLOS One*, 8:e84650.

Radioear B81. (2017). B-81 High output BONE TRANSDUCER. Retrieved June 21, 2017 from <http://www.radioear.us/pdfs/RadioEarB81.pdf>.

Ragert, P., Kalisch, T., Bliem, B., Franzkowiak, S., Dinse, H. R. (2008). Differential effects of vibrotactile high- and low-frequency stimulation on vibrotactile discrimination in human subjects. *BMC Neurosci*, 9, 1–9.

Raveh E, Attias J, Nageris B, Kornreich L, Ulanovski D. (2014). Pattern of hearing loss following cochlear implantation. *Eur Arch Otorhinol*, 272:2261–2266.

Richter, U. & Frank, T. (1985). Calibration of bone conduction vibrators at high frequencies. *Audiologische Akustik*, 24:52–62.

Stuart, M., Turman, A. B., Shaw, J., et al. (2003). Effects of aging on vibration detection thresholds at various body regions. *BMC Geriatr*, 3, 1.

Verrillo, R. T. (1963). Effect of contactor area on the vibrotactile threshold. *J Acoust Soc Am*, 35:1962–1966.

Wells, C., Ward, L. M., Chua, R., et al. (2005). Touch noise increases vibrotactile sensitivity in old and young. *Psychol Sci*, 16, 313–320.

Zanetti, D., Nassif, N., Redaelli De Zinis, L. O. (2015). Factors affecting residual hearing preservation in cochlear implantation. *Acta Otorhinolaryngol Ital*, 35:433–441.