



## **Low-energy buildings heat supply–Modelling of energy systems and carbon**

Downloaded from: <https://research.chalmers.se>, 2026-04-04 01:19 UTC

Citation for the original published paper (version of record):

Sandvall, A., Ahlgren, E., Ekvall, T. (2017). Low-energy buildings heat supply–Modelling of energy systems and carbon. *Energy Policy*, 111: 371-382. <http://dx.doi.org/10.1016/j.enpol.2017.09.007>

N.B. When citing this work, cite the original published paper.

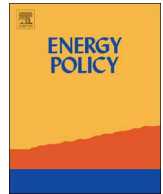

# Low-energy buildings heat supply–Modelling of energy systems and carbon emissions impacts

Akram Fakhri Sandvall<sup>a</sup>, Erik O. Ahlgren<sup>a,\*</sup>, Tomas Ekvall<sup>b</sup>

<sup>a</sup> Energy Systems Technology, Division of Energy Technology, Department of Energy and Environment, Chalmers University of Technology, SE-412 96 Gothenburg, Sweden

<sup>b</sup> Swedish Environmental Research Institute (IVL), SE- 400 14 Gothenburg, Sweden

## ARTICLE INFO

### Keywords:

Low-temperature district heating  
Fourth generation district heating  
TIMES  
Sweden  
Energy system modelling  
Dynamic impacts  
Passive houses

## ABSTRACT

Construction of new low-energy buildings (LEB) areas is attracting attention as a climate mitigation measure. Heat can be supplied to buildings in these areas through individual solutions, through a small, on-site heat network, or through a heat connection to a close-by district-heating (DH) system. The choice between these options affects the energy supply systems and their carbon emissions far beyond the LEB area. We compare the long-term systems impacts of the three heat-supply options through dynamic modelling of the energy systems. The study draws on data collected from a real LEB area in Sweden and addresses scale-dependent impacts on district heating systems. The results show that, generally, the individual and on-site options increase biomass and electricity use, respectively. This, in turn, increases carbon emissions in a broader systems perspective. The systems impacts of the large heat network option depend on the scale and supply-technologies of the DH system close to the LEB area.

## 1. Introduction

The world is rapidly becoming increasingly more urban. While in 1950 0.75 billion people (30%) were living in urban areas, in 2014 the corresponding figure was 3.9 billion (54%). This trend of urbanization is expected to continue (UN, 2014). Thus, in order to reach carbon mitigation targets, the carbon impacts of heating and cooling in new urban areas need careful consideration in particular considering the long lifetime of heating and cooling infrastructures. Today, in the European Union, the building sector accounts for 40% of the total energy consumption and 36% of the carbon dioxide (CO<sub>2</sub>) emissions (EC, 2015a).

In urban areas, various heating and cooling options may have widely different climate impacts, in particular when addressed in a systems perspective. Thus, it is the point of departure of this work that climate impacts of heating and cooling of future building areas should be addressed within a broad systems perspective since only then the full climate impact of the various heating and cooling options can be assessed. This is particularly true for district energy options being capable of improved resource efficiency by connecting to waste heat streams within the urban landscape.

Due to widely varying climatic conditions and thus varying demand for heating and cooling, and also due to large differences of the heating and cooling infrastructure in place today, the options for heating and

cooling to new building areas, and their climate impacts, differ between countries and localities. Hence, in order to provide for a better calculation accuracy, we will in this work focus on one country only. We have chosen to focus on Sweden. There are several reasons for this choice:

- The three heating and cooling options we will consider in this work are already widely applied in Sweden, and there are thus real cases, data and experience to build upon.
- There are strong plans for a huge expansion of the urban building stock (in 2015, the Board of Housing, Building and Planning (Boverket) forecasted that 700,000 new homes needed to be built in ten years (Boverket, 2016)). A large share of this is planned to be built according to low-energy buildings (LEB) standards (requiring only a small amount of space heating even during the cold seasons) (Valik and Petersson, 2015; SEA, 2012).
- The current heating sector is almost carbon neutral but future heating and cooling options might have a strong impact on the entire countries' possibilities to become carbon neutral in a few decades' time.
- There are governmental regulations for the calculation of energy use for space heating & cooling and hot tap water which might not lead to environmentally optimal solutions. (The Board of Housing, Building and Planning (Boverket) has proposed a method for

\* Corresponding author.

E-mail address: [erik.ahlgren@chalmers.se](mailto:erik.ahlgren@chalmers.se) (E.O. Ahlgren).

<http://dx.doi.org/10.1016/j.enpol.2017.09.007>

Received 4 January 2017; Received in revised form 30 August 2017; Accepted 2 September 2017

Available online 06 October 2017

0301-4215/ © 2017 The Authors. Published by Elsevier Ltd. This is an open access article under the CC BY-NC-ND license (<http://creativecommons.org/licenses/by-nc-nd/4.0/>).

**Nomenclature**

450PPM	450 ppm	IP	integer programming
BAU	business-as-usual	LDH	large district heating
Bio	Biomass	LEB	low energy buildings
CCS	carbon capture and storage	LTDH	low-temperature district heating
CHP	combined heat and power	MDH	medium district heating
CO <sub>2</sub>	carbon dioxide	MSW	municipal solid waste
DH	district heating	NG	natural gas
Eff	Efficiency	NGCC	natural gas combined cycle
EH	excess heat	NGGT	natural gas gas turbines
el	electricity	O & M	operation and maintenance
ELC_EXP	electricity generation	OIL1	light oil
ELC_IMP	electricity use	OIL5	heavy oil
EOL	end of life	PELLETS	bio pellet
ETSAP	Energy Technology System Analysis Program	RES	reference energy system
HOB	heat only boiler	SDH	small district heating
HP	heat pump	TIMES	The Integrated MARKAL-EFOM System
IEA	International Energy Agency	TPP	thermal power plant
IGCC	Integrated gasification combined cycle	UH	urban heating
		WGT	wind + gas turbine
		WOOD_CHIP	wood chip

calculation of the energy use for space heating & cooling, and hot tap water of the low-energy (near-zero energy) buildings. This method is based on a rather narrow systems boundary and only accounts for bought energy, which means that the use of free energy flows, i.e., from wind, sun, the ground, air and water are excluded from the calculation. Consequently, the proposed method promotes individual heat pumps not only in one-family buildings but also in apartment and public buildings (Boverket, 2015).)

In Sweden, the residential and service sector accounted for 40% of the total final energy use, 529 PJ (147 TWh) in 2013. About 60% of this was used in the heat sector for space heating and to provide hot tap water (SEA, 2015). Although the heat sector accounts for a large share of the total energy use, it is associated with very low CO<sub>2</sub> emissions. District heating (DH) has developed substantially since the 1960's and today accounts for over 60% of the heat market in the residential and service sectors (Frederiksen and Werner, 2013). While biomass, municipal solid waste (MSW) and industrial excess heat account for 72% of energy supply to the DH sector, fossil fuels, i.e. oil, natural gas and coal, have a share of only 8% (SDH, 2014). In addition, due to high fuel and CO<sub>2</sub> taxes on oil and natural gas, individual heat pumps are the main competitors of DH. In 2013, they supplied heat in 997,000 (52% of total) single-family and two-family detached buildings. In the same year, while DH use was 22 PJ (6 TWh), electricity and biofuels (e.g., wood chips and pellets) use in single-family and two-family detached buildings accounted for 54 PJ (15 TWh) and 40 PJ (11 TWh), respectively (SEA, 2015).

As indicated above, the choice of heating technology affects the energy systems far beyond the LEB area; also the entire DH system, the electricity system, and regional and international fuel markets are to various extents impacted. This should ideally be taken into account when deciding on directives on heat supply in new LEB areas. Investments in infrastructure have a long life, which means that there is a risk for lock-in effects into technologies for heating that are attractive today but might be a poor option in the future. To avoid such risks national directives on heat supply in new LEB areas need to take into account impacts not only in a wide but also in a long-term systems perspective in order to efficiently contribute to meeting international climate mitigation goals.

The options to supply heat to new LEB areas within or in the vicinity of urban areas can be divided into three categories: installation of a heat production device in each individual building, heating through a small on-site heat network, or through a heat connection to a DH

system in the urban area. The last option, the large heat network, assumes that there is a district heating (DH) system already in place in the urban area, which is the case in almost all urban areas in Sweden. The “on-site” option implies heat supply by a local district heating (DH) system within the LEB area, including a centralized heat production unit and a distribution network for heat distribution to each building. Similar to the “on-site” option, the “large heat network” option also includes a distribution network within the LEB area while the heat is produced in the DH system of the urban area and transmitted to the LEB area by a transmission pipeline.

Energy systems and carbon emissions (CO<sub>2</sub>) impacts of one or two of the heat supply options to energy efficient building areas have been studied before (Dalla Rosa and Christensen, 2011; Åberg, 2014; Lidberg et al., 2016; Mahapatra, 2015). Dalla Rosa and Christensen (Dalla Rosa and Christensen, 2011) compared low-temperature DH (LTDH) system with individual heat pumps in a new LEB area in Denmark and they showed that in the long-term the LTDH leads to 14.3% lower primary energy use. For Swedish cases, Åberg (2014) and Lidberg et al. (2016) presented consequences of energy savings in DH-connected multi-family buildings on current DH systems in terms of changes in fuel use, electricity generation and use and impact on global CO<sub>2</sub> emissions. Åberg (2014) modelled twelve DH systems with different DH production unit composition and different fuel use, and concluded that mainly fuel use for peak and intermediate DH load is reduced. Electricity generation is reduced when combined heat and power (CHP) is supplying the DH peak load. Lidberg et al. (2016) modelled the DH system of Borlänge and concluded that the biofuel and oil use in HOBs and the electricity input to heat pumps decreased, but that electricity generation from CHP plants would increase or decrease depending on the selected energy saving measures in the buildings. Mahapatra (2015) identified that DH supply to 180 new single- and two-family houses in Växjö, built based on Boverket's standards (Valik and Petersson, 2015), leads to less primary energy use and CO<sub>2</sub> emissions compared to individual heat pumps.

In contrast to the previous studies, in this study we will compare energy systems impacts and CO<sub>2</sub> emissions of the three heat supply options, for various types of district heating systems in a dynamic approach. The heat supply options will have a strong impact on the local energy systems but due to evolving biomass and international electricity markets, energy systems will indirectly be affected also far beyond the local scale. Thus, we will assess the impacts in a wider perspective. More specifically we account for the dynamics of the heat and electricity supply systems and for their interactions with each other and

with the buildings. We do this with an aim to assess the following three questions:

- How do fuel and electricity use and electricity generation vary between the three heat supply options?
- Which heat supply option is associated with the lowest long-term CO<sub>2</sub> emissions in the local and global energy systems?
- Is the application of a wide systems view of importance for the results and, thus, for the design of energy policies favoring carbon-lean heating options?

The analysis will focus on long-term impacts, and we will consider long-term marginal electricity generation for CO<sub>2</sub> emission calculations since changes in the local and regional electricity production can affect investment decisions elsewhere in the electricity system. Due to the very limited amount of cooling in Sweden we limit this study to an assessment of heating only.

## 2. Method

The study is carried out based on 1) creation of a range of cases to investigate, 2) dynamic energy system modelling, and 3) policy scenarios, sensitivity analysis and assumptions. The data used in the study are inspired by one real LEB area and three real DH systems (see Section 2.1). In order to be able to draw general conclusions under varying conditions, we combine these data into a hypothetical case of a new LEB area within or next to a DH system. A dynamic energy systems model, including the heat sector and part of the electricity and building sectors (see Section 2.2), is used for the calculations. Two scenarios (see Section 2.3) corresponding to different climate ambitions and one sensitivity analysis are designed and applied in order to test the robustness of the results.

### 2.1. Cases investigated

One LEB area and three DH systems are selected to generate the hypothetical cases. The LEB area is characterized by its plot ratio (i.e., the ratio of heated floor area to land area). The DH systems are characterized based on their size (measured as annual heat demand), energy sources and technologies to produce heat.

#### 2.1.1. Low-energy building area

The selected LEB area, constructed during 2011–2014, consists of 26 single-family houses, four small apartment buildings, six terraced houses, a nursing home for elderly people with 64 apartments and commercial buildings. It represents a mainly residential area with primarily single-family houses. All the buildings in the area were designed and built based on LEB requirements < 162 MJ/m<sup>2</sup>/year (< 45 kWh/m<sup>2</sup>/year) (Nielsen et al., 2014; Christensson and Eksta Bostads, 2015). The total heated area is 15,300 m<sup>2</sup>, the total annual heat demand in the area, including space heating and hot tap-water demand, is 2.72 TJ (756 MWh), and the annual heat density is 178 MJ/m<sup>2</sup> (49 kWh/m<sup>2</sup>) (Jimmefors and Östberg, 2014; Fahlén et al., 2014). The plot ratio is 0.15. The LEB area is located close to a small town (Kungsbacka) with an existing DH system in the Halland County in west Sweden.

In the modelled LEB area there is no disaggregation of the heat demand. The duration load graph for the area used as model input is shown in Fig. 1 (Jimmefors and Östberg, 2014; Fahlén et al., 2014).

#### 2.1.2. District heating systems

In order to capture the scale effects, we selected three DH systems of different size: a small-town DH (SDH) system, a medium-sized DH (MDH) system, and a large DH (LDH) system. Each of these has its own specific characteristics in terms of DH supply technologies and fuel use (see Table 1).

Our SDH system is inspired by the DH system of Kungsbacka. It has

a total annual heat supply of 0.378 PJ (105 GWh). The heat demand increases annually by approximately 14 TJ (4 GWh) due to DH network expansion (Statkraft, 2015). The SDH system currently includes a biomass combined heat-and-power (CHP) plant, biomass heat-only boilers (HOB), oil HOBs and a heat pump.

The MDH system is inspired by the DH system in the larger town Linköping and includes a biomass HOB, oil HOBs, an electric boiler, a coal CHP, oil CHPs, municipal solid waste (MSW) CHPs and a biomass CHP that meet the total annual heat demand of 4.72 PJ (1.31 TWh) (Difs et al., 2010).

The LDH system, inspired by the DH system in the city of Gothenburg, has an annual heat demand of 11.435 PJ (3.18 TWh) and includes biomass HOBs, oil HOBs, natural gas (NG) HOBs, industrial excess heat, heat pumps, an electric boiler, NG CHPs, a biomass CHP and a MSW CHP (GöteborgEnergi, 2014).

### 2.2. Dynamic energy system modelling

Energy system models can provide insights for long-term strategic energy planning. They also make possible the formalization of scattered knowledge about the complex interactions in the energy sector, and thinking in a structured way about the implications of changes to parts of the system (Pfenninger et al., 2014). A dynamic optimizing model of an energy system describes how the system should or will evolve over time to optimize a given parameter, such as system cost and CO<sub>2</sub> emissions (Serman, 1991).

For the purpose of this study we applied a local TIMES (The Integrated MARKAL (Fishbone and Abilock, 1981)-EFOM (Voort et al., 1984)System) model, TIMES\_UH (Urban Heating). In general, TIMES models (ETSAP, 2017; Gargiulo, 2009; Karlsson et al., 2015) are dynamic partial equilibrium optimization models, which can be used to optimize energy systems over a short to long-term period of time. The models are driven by an exogenously given demand for energy services, assuming a perfect foresight and applying a linear programming bottom-up approach. The TIMES model framework was developed by the International Energy Agency (IEA) implementing agreement Energy Technology System Analysis Program (ETSAP).

The TIMES\_UH model was developed and applied by Sandvall et al. (2016). It represents the heat sector only, implying that interactions between the heat sector and other sectors, i.e. the power, residential and transport sector, are exogenous. The model is driven by an exogenously given heat demand. The objective function of the model is net cost minimization. Revenues for electricity sale at exogenously assumed prices are accounted for in the calculation of the net cost. The model is a two-region model with the possibility to distribute heat between the two regions. One region consists of the LEB area and the other region consists of one of the three district heating systems (SDH, MDH or LDH). The reference energy system (RES) of the model is shown in Fig. 2.

The TIMES\_UH model divides the time span 2014–2052 into 10 time periods with shorter periods in the beginning: 2014, 2015, 2016–2017,

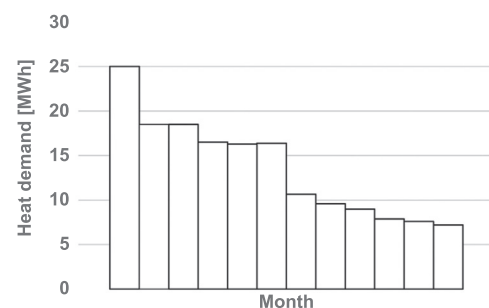

Fig. 1. The figure is showing the distribution of the annual heat demand, including hot tap water and space heating, of the 26 one-family houses in the LEB area in the form of a load duration graph (adapted from (Fahlén et al., 2014)).

**Table 1**  
Existing DH production technologies and their production capacity and end of life in the three DH systems.

Technology	SDH (Statkraft, 2015)				MDH (Difs et al., 2010)				LDH (GöteborgEnergi, 2014)			
	Heat capacity [MW]	Eff. <sup>d</sup>	EOL	Heat capacity [MW]	Eff.	EOL	Heat capacity [MW]	Eff.	EOL	Heat capacity [MW]	Eff.	EOL
<b>Heat-only plants</b>												
Biomass HOB	17.6	1.08	2022	42	0.85	2039	107	0.9	2025			
NG HOB	-	-	-	-	-	-	325	0.9	2021, 2025			
Oil HOB	34	0.9	2039	298	0.85	2039	628.5	0.9	2025, 2030			
Electric HOB	-	-	-	25	0.98	2021	8	1	2025			
Heat pump	2.8	2.3	2022	-	-	-	160	3.2	2025			
Industrial excess heat <sup>a</sup>	-	-	-	-	-	-	150	1	2052			
<b>Technology CHP plants</b>												
	Heat-to-power ratio	Electricity capacity [MW]	Eff (eI)	EOL	Heat-to-power ratio	Electricity capacity [MW]	Eff (eI)	EOL	Heat-to-power ratio	Electricity capacity [MW]	Eff (eI)	EOL
MSW CHP <sup>b,c</sup>	-	-	-	-	1.9/ 3.86	47.4/ 15.4	0.31/0.22	2052	7	20.4	0.11	2052
Biomass CHP	9	0.8	2021	2021	5.06	10.8	0.18	2024	9.23	13	0.12	2025
NG CHP <sup>c</sup>	-	-	-	-	-	-	-	-	1.2/2.8/1.12	12.9/36/ 261	0.39/0.24/ 0.43	2015, 2025
Oil CHP <sup>c</sup>	-	-	-	-	3.55/ 1.05	30/ 12	0.2/0.39	2039	-	-	-	-
Coal CHP	-	-	-	-	3.84	12	0.19	2024	-	-	-	-

Abbreviations: Efficiency (Eff), electricity (eI), End of life (EOL), Heat only Boiler (HOB), Heat only Boiler (HOB), NG (Natural Gas), MSW (municipal solid waste), and CHP (Combined Heat and Power).  
<sup>a</sup> Industrial excess heat is continuously available over the entire year.  
<sup>b</sup> Since the MSW CHP is run mainly to manage the waste, we assume investments in MSW CHP not to be affected by changes in the heat demand. However, the fuel (MSW) availability is limited to 1000 GWh/year (TekniskaVerken, 2014) and 1700 GWh/year (GöteborgEnergi, 2014) in the medium and large DH system, respectively.  
<sup>c</sup> When there are more than one plant with different heat to power ratios, the electricity generation capacity of each plant and its corresponding heat to power ratio and electric efficiency are given (separated with /).  
<sup>d</sup> Efficiencies are based on the lower heating value.

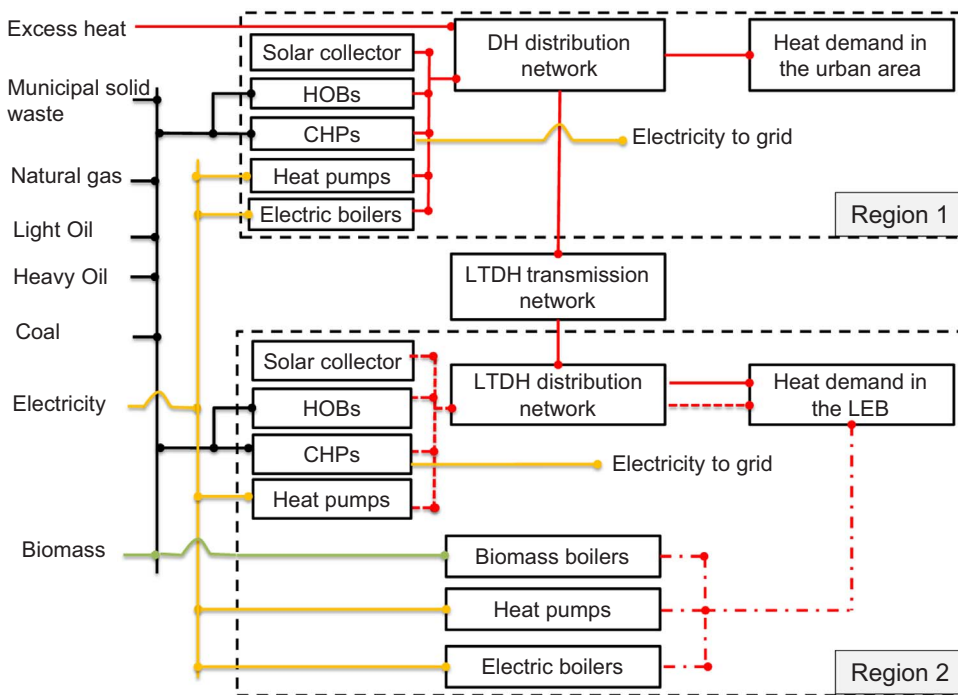

Fig. 2. The figure presents the modelled reference energy system (RES).

and 5-year periods from 2018. Each year has been divided into eight time slices, representing day and night in four different seasons: summer (6 months duration), spring/fall (3 months), winter (2 months) and cold winter (1 month). Daytime lasts 8 h, 8 h, 12 h and 16 h per day during winter, cold winter, spring/fall and summer, respectively. The LEB area is assumed to be built in 2015, and the heat demand of each building type is defined for each time slice.

### 2.2.1. Model calculations

We applied the TIMES\_UH model to calculate fuel and electricity use, electricity generation and the associated CO<sub>2</sub> emissions for each of the three heat supply options. In each scenario (see Section 2.3) we ran the model in four Modes over the entire model time span, 2014–2052, discounted to 2014 with an annual discount rate of 5% (chosen in order to represent a societal rather than a business perspective):

1. Mode 1: Individual heat supply in the buildings in the LEB area (the individual option)
2. Mode 2: DH produced and used within the LEB area (the on-site option)
3. Mode 3: DH produced for use within the nearby town
4. Mode 4: DH produced in the nearby town for use in both the town and LEB area

Modes 1 and 2 include the LEB area only, while Mode 3 includes one of the three DH systems, and Mode 4 includes the LEB area and one of the DH systems.

The annual energy flows and CO<sub>2</sub> emissions associated with heating of buildings in the LEB area are directly calculated (at each time period) for the individual and on-site options by the model (Mode 1 and Mode 2, respectively) while for the large heat network they are obtained by inserting the model results in Eq. (1):

$$X_i(\text{Large heat network}) = X_i(\text{Mode 4}) - X_i(\text{Mode 3}) \quad (1)$$

where X is the annual energy flows or CO<sub>2</sub> emissions associated with heating of buildings in the LEB area and/or in the urban area, and i represents the three DH systems.

The average annual energy flows and CO<sub>2</sub> emissions per unit of heated floor in the LEB area are calculated by Eq. (2):

$$Y = \left( \sum_{j=1}^{10} (X \text{ at period } j) * (\text{number of years in period } j) \right) / \text{total number of years/heated floor in the LEB area [m}^2] \quad (2)$$

### 2.2.2. Model assumptions

The DH systems in the TIMES\_UH model are based on data of the existing production units in the real DH systems, as described in Section 2.1.2 (Table 1). The representation of the DH systems in the model also include details on the conversion efficiency and availability of these plants, the annual heat demand and heat duration curve, and the efficiency of the DH distribution networks in different seasons.

From 2015 the model should invest in new DH production capacity in the LEB area and the close-by DH system, in a LTDH distribution network, or in individual heat production technologies in the LEB area. The available investment options are described in Table 2, Table 3 and Table 4, respectively.

In order to capture economies of scale and constraints with regards to lower size limits of advanced technologies, all investment in DH supply and distribution as well as individual heat production technologies in the LEB area can only be made at discrete capacity levels. This implies that the model investment options are representing real conversion efficiencies and cost of the specific plants sizes, i.e. that conversion efficiencies generally increase and specific cost decrease with increasing plant size. Thus, these investment options change the linear model into an integer programming (IP) model.

The heat demand of the LEB area and its annual profile is assumed to be constant during the time horizon of the study. This is based on the assumption that the houses are constructed according to low energy building standards and that they are just constructed at the start of the study. The heat demand is assumed to be inelastic, implying that it is not being affected neither by changing income of the residents nor by changing cost of heating.

The heat demand of the SDH is, as already mentioned in Section 2.1.2, assumed to increase by 14 TJ (4 GWh) annually in accordance with the plans of the municipality. The heat demand of the MDH and LDH is assumed to be constant during the entire time horizon of the study. This assumption is based on different heating demand trends: demand decreases due to global warming and due to better building

**Table 2**

Main input data on DH technologies in the LEB area, and in the small, medium and large DH systems. Assumptions based on Danish data sources (Technology Data, 2012, 2010) and on Nohlgren et al. (2014). The operation costs in this table exclude costs of fuel and electricity used in the plants. For assumptions on fuel and electricity prices, see Table 6. Data for model year 2015 and 2050 are separated with /.

Technology	Parameter	Unit	Value
<b>Heat plants</b>			
<i>(with their heat capacity)</i>			
<b>Biomass HOB</b> (0.5 MW – 50 MW)	Total efficiency <sup>a</sup>	–	1.08
	Specific investment cost <sup>b</sup>	[k€/kW <sub>heat</sub> ]	0.35 – 1.3
	Total O & M cost (25 MW – 50 MW)	[% of inv. cost/year]	6.7
	Total O & M cost (0.5 MW – 20 MW)	[€/MWh <sub>heat</sub> ]	5.4
	Lifetime	Year	20
<b>Oil and natural gas HOB</b> (0.5 MW – 20 MW)	Total efficiency	–	0.97
	Specific investment cost <sup>b</sup>	[k€/kW <sub>heat</sub> ]	0.061 – 0.13
	Total O & M cost <sup>b</sup>	[% of inv. cost/year]	0.05 – 2.0
	Lifetime	Year	35
<b>Heat pump</b> (0.5 MW – 10 MW)	Coefficient of performance (COP)	–	3.7
	Specific investment cost <sup>b</sup>	[k€/kW <sub>heat</sub> ]	0.49 – 1.1
	Total O & M cost	[% of inv. cost/year]	0.7
	Lifetime	Year	20
<b>Solar collector<sup>c</sup></b>	Specific investment cost	[k€/m <sup>2</sup> ]	0.23/0.17
	Total O & M cost	[€/MWh <sub>heat</sub> ]	0.57
	Lifetime	Year	30
<b>Combined heat and power plants</b>			
<i>(Electricity capacity)</i>			
<b>Biomass CHP</b> (0.6 MW – 100 MW)	Efficiency Electricity (Total) <sup>a,b</sup>	–	0.25 – 0.46 (1.03 – 1.05)
	Specific investment cost <sup>b</sup>	[k€/kW <sub>Electricity</sub> ]	1.37 – 7.0
	Total O & M cost <sup>b</sup> (capacities up to 70 MW)	[% of inv. cost/year]	0.7 – 3
	Total O & M cost (capacities above 70 MW)	[€/MWh <sub>Electricity</sub> ]	3.2
	Lifetime	Year	20 (below 10 MW) 30 (above 10 MW)
<b>NGCC CHP</b> (10–400 MW)	Efficiency Electricity (Total) <sup>b</sup>	–	0.48 – 0.58 (0.9 – 1.0)
	Specific investment cost <sup>b</sup>	[k€/kW <sub>Electricity</sub> ]	0.82 – 1.5
	Total O & M cost	[€/MWh <sub>Electricity</sub> ]	2.5
	Lifetime	Year	25
<b>NGGTCHP</b> (5–125 MW)	Efficiency Electricity (Total) <sup>b</sup>	–	0.42 – 0.5 (0.82 – 0.92)
	Specific investment cost <sup>b</sup>	[k€/kW <sub>Electricity</sub> ]	0.46 – 1.2
	Total O & M cost	[€/MWh <sub>Electricity</sub> ]	3.4 – 7
	Lifetime	Year	25

Abbreviations: CHP: combined heat and power; HOB: heat only boiler; NG: natural gas; MSW: municipal solid waste; CC: combined cycle; GT: gas turbine; O & M: operation and maintenance.

<sup>a</sup> Efficiencies are based on lower heating value.

<sup>b</sup> Due to the scale of economy, the larger plants have lower specific investment cost and total O & M costs. Larger CHP plants, in addition, have higher electricity efficiency.

<sup>c</sup> Collector output is 0.5 MWh/m<sup>2</sup>/year. Availability factor of the technology is 0.34, 0.2, 0.09 and 0.06 in summer, intermediate, winter and cold winter, respectively.

stock insulation as a consequence of housing refurbishment, and an increasing demand due to DH system expansions, in turn due to city growth and densification.

### 2.3. Policy scenarios and related assumptions

#### 2.3.1. Policy scenarios

The long-term impacts of the heating options depend on how the energy systems develop over time. This will depend on, for example, future fuel and electricity prices, which are highly uncertain and strongly affected by, for example, policies on energy and climate. We

develop and apply two policy scenarios to account for part of this uncertainty: 450PPM and Business as usual (BAU). The scenarios are based on the 450 ppm and New Policies scenarios, respectively, of the IEA World Energy Outlook (World Energy Outlook, 2013).

The 450PPM scenario includes ambitious climate policies in line with the Paris Agreement aiming at limiting global warming to below 2 °C (EC, 2015b). At the national level the 450PPM scenario assumes a political ambition to phase out fossil fuels in the heat sector until 2030. The less ambitious BAU scenario includes policy commitments and plans that had been announced before the Paris Agreement, including national pledges to reduce greenhouse gas emissions and plans to phase

**Table 3**

Characteristics and costs of the LTDH network (supply/return temperature: 55/25 °C) in the LEB area based on Sandvall et al. (2016).

Heat demand	Plot ratio	Distribution efficiency (Li and Svendsen, 2012; Dalla Rosa et al., 2014)	Specific investment cost <sup>a</sup>	Fixed O & M cost	Variable O & M cost	
[GJ/year]	-	Summer/Spring & fall/Winter/Cold winter	[€/kW]	[% of inv. cost/year]	[€/MWh <sub>heat</sub> ]	
LEB area	2720	0.15	0.63/0.85/0.9/0.915	2830	1.2	3.57

Abbreviation: O & M: operation and maintenance.

<sup>a</sup> The investment cost includes both the cost of DH network and substations. A lifetime of 50 years is assumed for the investments in the DH distribution network.

**Table 4**

Main input data on individual heat supply options in the LEB area, from single-family houses to nursing home. Assumptions based on data from the Danish Energy Agency (Danish Energy Agency, 2012). The wholesale prices of bio pellets and electricity are not included here but in Table 6. However, the operation costs in this table include the additional price households pay for bio pellets and electricity to cover costs of delivery etc. Assumptions on this additional cost are based on current market prices and on data from the Swedish Energy Market Inspection (EMI, 2015).

Technology (and its heat capacity)	Parameter	Unit	Value <sup>a</sup>
<b>Bio pellet boiler</b> (6 kW – 110 kW)	Efficiency	–	0.8
	Specific investment cost	[k€/kW <sub>heat</sub> ]	0.31 – 0.73
	Fixed O & M cost	[% of inv. cost/year]	0.27 – 2.1
	Variable O & M cost	[€/MWh <sub>heat</sub> ]	36
	Lifetime	Year	20
<b>Heat Pump - brine to water</b> (5–110 kW)	Coefficient of performance (COP)	–	3.3
	Specific investment cost	[k€/kW <sub>heat</sub> ]	1.77 – 4
	Total O & M cost	[% of inv. cost/year]	2 – 22.6
	Lifetime	Year	20
	Efficiency	–	1
<b>Electric boiler</b> (5–110 kW)	Specific investment cost	[k€/kW <sub>heat</sub> ]	0.7 – 0.8
	Total O & M cost	[% of inv. cost/year]	1.6 – 15
	Lifetime	Year	30

Abbreviation: O & M: operation and maintenance.

<sup>a</sup> Due to the scale of economy, the larger plants have lower specific investment cost and fixed/ total O & M costs.

out fossil fuel subsidies. Fuel prices and technology will develop over time, but the policies basically stay the same. Table 6 presents the policy and fuel price assumptions applied in the study for the two scenarios and how these are assumed to develop over time.

### 2.3.2. Sensitivity analysis

We make a sensitivity analysis within each policy scenario to investigate specifically the climate impacts of a choice of heat pumps (in line with the energy efficiency calculation advice given by the Swedish Board of Housing, Building and Planning (Boverket) as described in Section 1). The sensitivity analysis can be described as a set of two what-if scenarios (Börjeson et al., 2006):

- “OPTIMAL”, where the model selects the economically optimal investment option in the individual heat supply option, and
- “Only\_HP”, where the heat pump is the only technology available

**Table 5**

Technologies chosen for the short-term marginal electricity production in the TPP path. The same figures are also used for the calculation of the TPP path built margin carbon emissions. Conversion efficiencies are based on IEA scenarios (IEA, 2014). For parameter values, which are not constant over the whole model time period, values for different time periods between 2014 and 2052 are given (separated with /). Efficiency is not given (-) if the associated technology is not used in a time period.

Fuel input	Technology	Season	Efficiency	
			2014–2020/ 2025–2035/ 2040/2050	
			450PPM	BAU
Coal	Steam Coal_subcritical	Cold winter	0.39/0.39/-/-	0.39
	Steam Coal_supercritical	Winter	0.43/0.43/-/-	0.43
	Steam Coal_Ultra supercritical	Spring/fall	0.46/-/-/-	0.46/0.47/0.49/0.49
	IGCC	Summer	0.45/-/-/-	0.45/0.47/0.51/0.51
Natural gas	CCGT	Spring/fall	-/0.61/0.63/-	–
		Summer	-/0.61/0.63/-	–
	Gas turbine	Winter/cold winter	-/-/0.42/-	–
	CCGT + CCS	Spring/fall/summer/winter/cold winter	-/-/-/0.56	–

Abbreviations: IGCC (Integrated gasification combined cycle); CCS (carbon capture and storage); CCGT (combined cycle gas turbine).

for heating of buildings in the LEB area in the individual heat supply option.

### 2.3.3. Indirect impacts on energy markets

Our model calculates CO<sub>2</sub> emission changes associated with heating of buildings in the LEB area at different systems scales due to scenario dependent future alternative biomass utilization and electricity market developments.

Biomass is a renewable but limited source of energy. The direct net CO<sub>2</sub> emissions of biomass use is in the model equal to zero. However, since biomass is a limited resource, its use in the heating sector reduces its potential use in the transport and/or power sectors and, indirectly, thus impacts the climate impacts of these sectors. The indirect climate impact is highly uncertain and depends on what alternative use of the biomass is affected. Our study includes different possible indirect impacts in order to better capture the climate impacts of biomass use for heating. As one extreme, in the 450PPM scenario we assume that the alternative use of biomass is to displace coal in a power plant. This means that the use of biomass for heating in this scenario will be associated with emissions of 336 kg CO<sub>2</sub>/MWh fuel (Djuric Ilic and Trygg, 2014). As the other extreme, we assume no alternative use of biomass to be affected in the BAU scenario, in which the lower climate ambitions reduce the pressure to use biomass in other energy sectors. This means biomass use is assumed to be, in fact, climate neutral in the BAU scenario.

The heat sector interacts with the power sector through heat pumps, electric boilers and CHP plants. Consequently, the choice of heat production technology would in the long-term affect the investment decisions elsewhere in the electricity system (i.e., the built margin in the electricity system (Sjodin and Grönkvist, 2004)). With a European electricity system perspective, the model calculates the net CO<sub>2</sub> emissions based on the built margin. The built margin depends not only on climate policy scenarios but also on other factors that affect future electricity prices and on other considerations of the power companies. Thus, in addition to our two climate policies, 450PPM and BAU, we assume two paths for technological changes in the power sector: a “thermal power plants” (TPP) path and a “wind + gas turbines” (WGT) path. While the TPP path is economically optimized given the assumed climate policy scenarios, the WGT path reflects a case when the investment decisions are strongly affected by environmental concerns of the power companies.

With the TPP path, in 450PPM, marginal emissions of electricity are assumed to be based on combined cycle gas turbine plants until 2040. Moreover, the carbon capture and storage (CCS) technology is assumed to be available after 2040. In BAU, marginal emissions of electricity are assumed to be based on a mix of coal power plants with different efficiencies for each model time slice (Table 5).

In almost all European countries, governments strongly support investments in renewable energy sources such as wind and solar in the power system. In order to integrate these intermittent renewable energy sources, investments in flexible power plants (e.g., gas turbines) or other flexibility measures are needed to provide services and to cover demand. Thus, with the WGT path we assume wind and gas turbines with the combination of 70% and 30%, respectively, to be the long-term marginal built power generation 2025–2040 (450PPM) and 2025–2050 (BAU). In the first model time periods (2015–2020), the marginal built power generation is the same as with the TPP path. In the last time periods (2040–2050) of the 450PPM scenario, in accordance with the TPP path, CCS technology is available.

#### 2.3.4. Energy prices

The fuel and electricity price assumptions are a consequence of the climate policies (including resulting CO<sub>2</sub> charges) in the respective scenario (Table 6).

In addition to the CO<sub>2</sub> charge, both scenarios include a subsidy supporting renewable electricity generation. The subsidy level is constant at 5.6 €/GJ<sub>electricity</sub> (20 €/MWh<sub>electricity</sub>) until 2020, in line with historical values of tradable green certificates in Sweden, and thereafter linearly declines and reaches zero in 2030 (Table 6).

In the 450PPM scenario, wood chip prices correspond to the regional/local marginal cost of forest residues until 2030. After that, it is assumed that with increasing CO<sub>2</sub> charges competition for biomass between different energy sectors creates an international market for unrefined biomass, leading to increasing wood chip prices. In the BAU scenario, with lower climate ambitions, the wood chip price is assumed to be equal to the production cost and thus remain constant (Table 6).

Electricity prices are calculated based on the assumption that the variable cost of the short-term marginal technology (i.e., the sum of fuel cost, CO<sub>2</sub> charge and variable operation and maintenance cost) determines the electricity price. Since the short-term marginal technology depends on the CO<sub>2</sub> charge, the price is scenario dependent.

### 3. Results

Even without the construction of an LEB area, the DH production in the three DH systems will change over time both in terms of DH

**Table 6**

Summary of input data for the 450PPM and BAU scenarios. For the parameter values, which are not constant over the whole model time period, values for different time periods between 2014 and 2052 are given (separated with /).

	Unit	450PPM 2014/2020/2030/2040/2050	BAU 2014/2020/2030/2040/2050
<b>Policy tools</b>			
CO <sub>2</sub> charge	€/tonne	16.9/25.2/68.4/110/153	16.9/14.4/23.8/33.5/43
Renewable electricity subsidy	€/MWh	20/20/0/0/0	20/20/0/0/0
<b>Energy prices/costs<sup>a</sup></b>			
Natural gas	€/MWh	28.7/28.3/25.1/22/18.5	28.7/29.2/30.2/32/33
Fuel oil, light	€/MWh	64.2/64.7/61.8/58/54.9	64.2/66.2/70/75/80
Fuel oil, heavy	€/MWh	41.6/42/39.8/37.2/34.6	41.6/43.1/46/50/53.5
Coal	€/MWh	8.8/8.9/7.6/6/4	8.8/9.4/9.7/9.7/9.7
Wood chip	€/MWh	20/20/20/40.5/55	20
Bio pellet	€/MWh	35/44/50/59/78	35/41/45/50/53
Excess heat <sup>b</sup>	€/MWh	0.56	0.56
MSW <sup>c</sup>	€/MWh	–14.5	–14.5
<b>Electricity</b>			
Winter cold (1 month)		55.2/62.9/98/122.2/74.4	55.2/54.6/63.8/72.5/80.9
Winter (2 months)		54.3/61.4/93.2/122.2/74.4	54.3/53.7/62.1/70/77.6
Spring and fall (3 months)	€/MWh	51.3/57.9/73.1/80/74.4	51.3/50.8/57/60.8/67.5
Summer (6 months)		51.3/64.2/73.1/80/74.4	51.3/50.8/63.2/61.4/67.8

Abbreviation: municipal solid waste (MSW).

<sup>a</sup> Fuel and electricity prices are prices at the gate of DH plants. Fossil fuel prices are based on IEA World Energy Outlook (World Energy Outlook, 2013). They do not include CO<sub>2</sub> charges.

<sup>b</sup> For excess heat, the value represents an assumed minimum compensation for excess heat providers over and above the technical costs of bringing the heat to the DH system - it does not represent a market price.

<sup>c</sup> For MSW the fuel price is negative because the plant owner charges a gate fee for treating the waste (Nohlgren et al., 2014).

production technology and fuel use (Fig. 3). The investments in new DH production plants vary widely between the models. In the 450PPM scenario, heat pumps dominate investments in the SDH, heat pumps and bio-HOB being the plants selected in the MDH, while in the LDH the largest investment will be in bio-CHP. In the BAU scenario, new heat pump and bio-HOB will be combined with new oil capacity for peak production in the SDH and MDH models. In the LDH the major change compared to today's heat production mix is a new NGGT-CHP. Hence, the economically efficient investments depends, in the models, both on the climate policy scenario and on the size of the DH system.

#### 3.1. Impacts of the LEB area on energy flows

The heat-supply options in the LEB area have various impacts on the energy flows (Fig. 4). When the model is free to choose the cost-efficient technology for heating of individual houses, it selects bio-pellet boilers. When forced to use heat pumps, 75% less energy is used because the results do not include the free geothermal heat extracted with these heat pumps. Heating through a small, on-site heat network has similar effects on the energy flows, because the model in this case selects heat pumps as the cost-efficient technology.

Connecting the LEB area to a DH system can have a complex impact on investments and DH production in the model, causing the use of some energy carriers to increase while the use of other energy carriers is reduced (Fig. 4). When heating in the LEB area is provided from a DH system, the effects on the energy flows depend strongly on the DH system modelled but also on the climate policies. If the LEB area is connected to the large DH system in the 450PPM scenario, the use of natural gas CHP is greatly reduced in the model, leading to reduced electricity generation in the CHP plant (yellow dots in Fig. 4a). Instead, the use of large heat pumps increases (represented by imported electricity in Fig. 4a).

In the BAU scenario, on the other hand, the heat demand from the LEB area increases electricity generation in the natural gas-fueled CHP plant in the model of the large DH system (the yellow dots in Fig. 4b).

#### 3.2. Impacts on CO<sub>2</sub> emissions

Fig. 5 shows how heating the LEB area affects the average annual

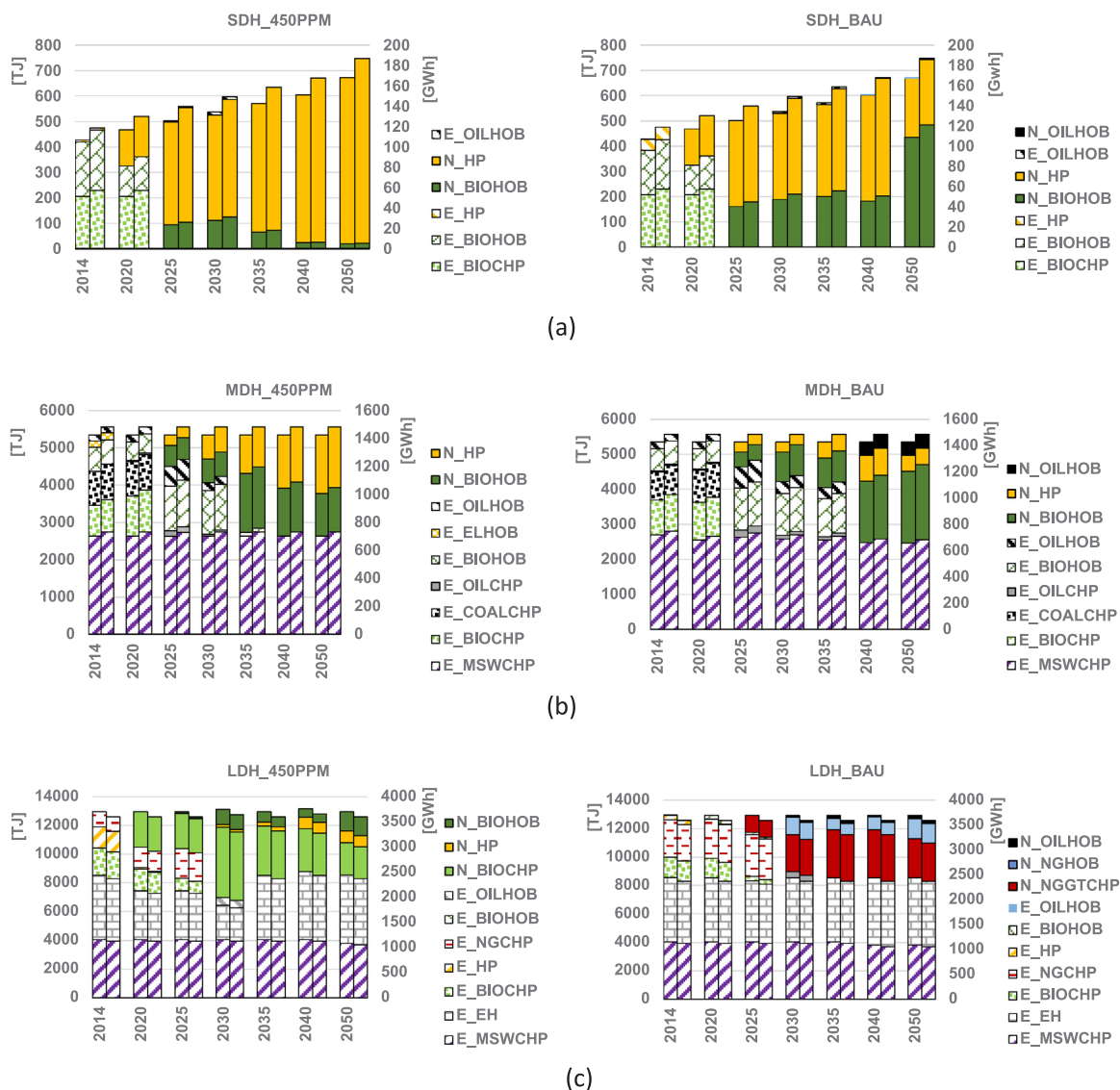

Fig. 3. Development over time of the heat production in SDH (a), MDH (b) and LDH (c), 2014–2052; 450PPM (left) and BAU (right). Abbreviations: existing (E), new (N), municipal solid waste (MSW), excess heat (EH), biomass (BIO), heat pump (HP), natural gas (NG), heat-only boiler (HOB), combined heat and power (CHP).

CO<sub>2</sub> emissions in the model. The impacts on emissions are presented with three systems perspectives:

- Impacts on local CO<sub>2</sub> emissions, i.e., emissions that occur in the LEB area or the nearby DH system,
- impacts on local emissions and on emissions associated with built marginal changes in the electricity supply (with two different paths for the development of the electricity system), and
- impacts on local emissions, on emissions associated with marginal electricity, and on emissions associated with the alternative use of biomass (in the 450PPM scenario only).

There are no local emissions of fossil CO<sub>2</sub> in our model of heating of individual buildings or through small on-site heat networks in the LEB area, because the technologies used in the model are heat pumps and bio-pellet boilers. The use of electricity and biomass is, however, associated with indirect emissions impacts from other parts of the system.

When the model is free to select bio-pellet boilers for heating of individual houses, the only net impact on CO<sub>2</sub> emissions is from the alternative use of the biomass in the 450PPM scenario. These emissions are large because the use of bio pellets is in this scenario assumed to reduce the use of biomass in coal-power plants. This can be considered the maximum climate impact associated with the use of bio pellets in Sweden.

Heat pumps in individual buildings or in the on-site heating network also have no local emissions but are allocated emissions from the marginal increase in electricity production. These emissions depend on how the electricity system evolves, which, in turn, can depend on the policy scenario. The climate impact is the greatest in the TPP path in the BAU scenario, where the marginal electricity is provided through a mix of coal-based technologies (cf. Table 5).

When heat in the LEB area is provided from a DH system in the model, the effects on the CO<sub>2</sub> emissions, just like the impacts on energy flows, depend strongly both on the DH system and on the climate

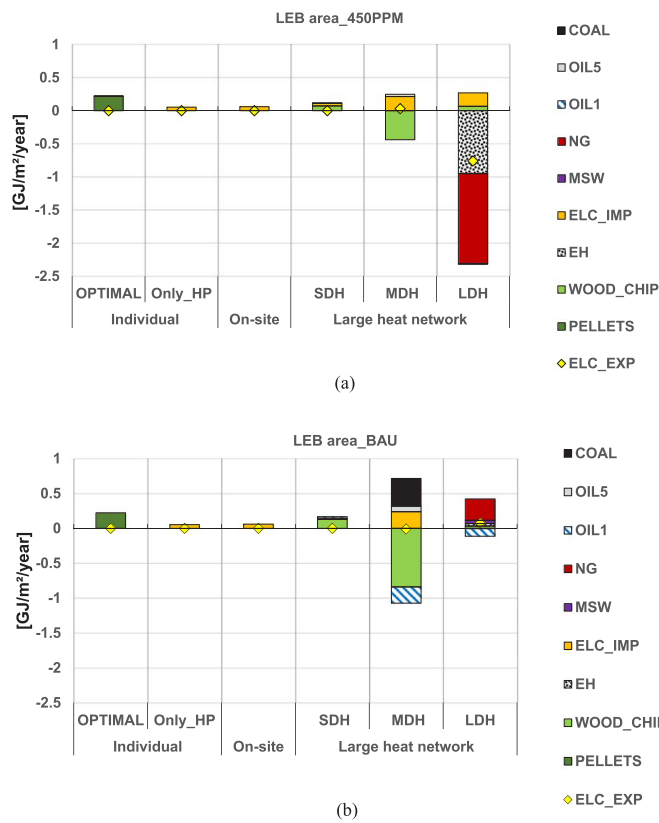

Fig. 4. Average annual fuel and electricity use and electricity generation in the individual (optimal and only-heat pump), on-site and large heat network options per unit of heated floor in the LEB area; (a) 450PPM, (b) BAU. Abbreviations: municipal solid waste (MSW), excess heat (EH), wood chip (WOOD\_CHIP), electricity generation (ELC\_EXP), electricity use (ELC\_IMP), bio pellet (PELLETS), natural gas (NG), light oil (OIL1), heavy oil (OIL5).

policies. If the LEB area is connected to the small DH system, the use of biomass and possibly electricity increases in this system (Fig. 4). This means that the climate impacts will depend on the alternative use of biomass and on the marginal electricity production, which both vary between policy scenarios (Fig. 5).

The impacts on the energy flows in the models of the medium-sized and large DH systems are complex (Fig. 4). This is also reflected in the climate impacts (Fig. 5). In the model of the MDH system, LEB heating increase electricity use. This results in increased emissions from marginal electricity production, particularly in the coal-based TPP path within the BAU scenario. On the other hand, biomass use decreases in the MDH, which means that more biomass is available for reducing CO<sub>2</sub> emissions elsewhere. In the 450PPM scenario, where this potential is used to its maximum, the alternative use of biomass is much more important than the increase in local emissions and electricity use. The yellow and blue bars in Fig. 5a show that the net total impact of LEB heating on the MDH system is a large reduction in the CO<sub>2</sub> emissions in this scenario. In the BAU scenario, however, the potential for alternative use of biomass is not utilized and the net total CO<sub>2</sub> emissions are greatly increased (Fig. 5b).

Providing LEB heating from the LDH system in the 450PPM scenario reduces the use of fossil fuel in the model of this system. This means that the local emissions are strongly reduced. On the other hand, net electricity production in this systems model is also greatly reduced, which means increased emissions from marginal electricity production.

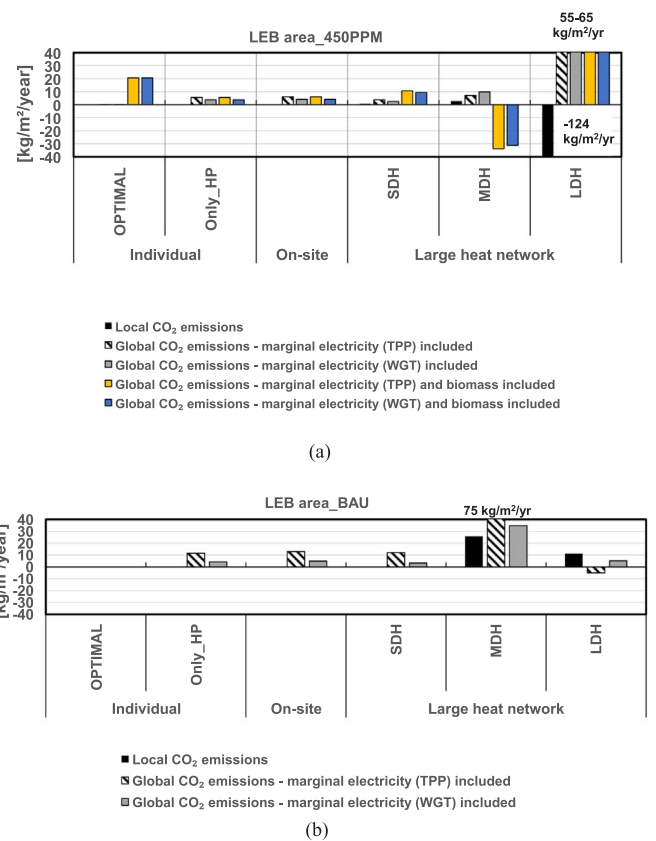

Fig. 5. Average annual local and global CO<sub>2</sub> emissions per unit of heated floor in the LEB area in the individual (optimal and only-heat pump), on-site and large heat network options; (a) 450PPM, and (b) BAU scenarios.

The total impact is a large increase in CO<sub>2</sub> emissions (Fig. 5a).

The impacts on the LDH system are less dramatic and more apparently realistic in the BAU scenario. Heating the LEB system will in this case increase the use of natural gas but also slightly increase the electricity generation in the local CHP plants. This will increase the local CO<sub>2</sub> emissions. The total climate impact will depend on what marginal electricity is substituted by the electricity from the LDH system.

#### 4. Discussion

Our results are calculated for two different policy scenarios and two paths for the development of the power supply. We do not consider any of these scenarios or paths more likely than the other. Any combination of these may occur in future. Other scenarios and paths are also possible. Thus, our study aims not to predict the actual impacts of LEB heating but instead to show the span of plausible results.

For this purpose, we applied extreme assumptions regarding the alternative use of biomass: substituting coal in the 450PPM scenario and no alternative use in the BAU scenario. The biomass could also, for example, replace diesel in the transport sector (Sandvall et al., 2015). This would have less impact on CO<sub>2</sub> emissions, and result in shorter yellow and blue bars in Fig. 5a. However, the technology for producing transport fuels from forest biomass (in bio-refineries) is still under development, whereas biomass use in coal power plants has been practiced.

The results from bio-pellet boilers (OPTIMAL individual) and the

small DH system show that the higher efficiency of boilers in the DH system more than compensates for the losses in the distribution of the heat in the DH system. Cogeneration of heat and electricity can add to the benefits of DH systems, as illustrated by the LDH results in Fig. 5b. This shows that producing and distributing heat in LTDH systems can bring environmental benefits even when heating small LEB areas. However, our results also indicate that the impacts on the DH system can be complex and that the net impact on the total CO<sub>2</sub> emissions is highly uncertain.

We applied an integer programming model of the energy system, where most new investments can only be made at discrete capacity levels. This reflects the fact that both the specific heat plant costs increase whereas conversion efficiencies decrease with decreasing scale and that advanced technologies like CHP cannot be built at very small scales. Our results indicate that capturing such economy-of-scale effects is essential in a study of a mix of small (like the individual option) and large scale (district heating) heat plants. The integer programming forces the model to better mimic real-world conditions: the construction of very small DH plants is not realistic. However, compared to linear modelling, integer programming models are associated with certain limitations, for example the risk of flip-flop events: a small change in the exogenously defined heat demand can result in a very different optimal path for the DH system in the model. Adding the relatively small annual heat demand of the LEB area to the much greater demand in the MDH and LDH systems can thus have dramatic effects in the model as illustrated both in Fig. 4 and Fig. 5. These results are due to the integer properties of the model rather than real causal relationships. A combination of linear and discrete plant-specific cost and conversion efficiency assumptions is probably a way of progress that combines the advantages of both approaches and limits the drawbacks.

On the other hand, the usual TIMES model framework assumes that decisions are made based on strict economic rationality and full knowledge about future prices etc. In reality decisions are made with limited knowledge about the future and based on a mix of motives. The information that a new LEB area will be constructed and add to the DH demand might, in the right point in the decision process, contribute to completely changing the course for the DH system. This does not mean that the dramatic results in Fig. 4 and Fig. 5 reflect the real consequences for the MDH and LDH systems in the 450PPM and BAU scenarios; however, these results serve as a reminder that also small changes can have large impacts, and that the real impacts are very difficult to predict.

## 5. Conclusions and policy implications

In this study we applied techno-economic least-cost optimization modelling to investigate the long-term, dynamic energy system and carbon emission impacts of three different options for heating a low-energy building area located in Sweden: an individual, an on-site and a large heat-network option. The latter was represented by district heating systems of three different scales. Two different climate policy scenarios were applied: a scenario representing current climate policies and a scenario in line with a 2-degree climate target.

The model selects bio-pellet boilers as the individual heating option and heat pumps as the on-site heating option. This is independent of the scenario. The model results also indicate that a small additional heat demand from low-energy buildings could have a rather complex impact on the production in a district-heating system. This impact also depends strongly both on the district-heating system and on the policy scenario.

Since the individual and on-site heat supply is likely to be associated with increased use of biomass and electricity, respectively, this in turn would increase global CO<sub>2</sub> emissions if the system perspective is expanded to include alternative use of biomass and marginal electricity generation outside of the local energy system. The actual effects of adding the extra heat demand to a specific district heating system are highly uncertain, since decisions in the DH system are made with

limited knowledge about the future and based on a mix of motives. Hence, it is not possible, based on this study, to make a general statement that district heating is better for the climate than individual or on-site solutions in low-energy building areas. However, for climate-concerned futures (the 450PPM scenario), and for LEB areas situated within or close to larger DH-systems, the wide systems approach applied to the MDH indicates much lower carbon emissions than the other heating options.

Our results confirm the view that a wide systems perspective is important to account for indirect effects of residential heating, such as effects on the electricity production and on the use of biomass in other parts of the energy system. However, our results also illustrate that these indirect effects are highly uncertain.

Thus, the results imply, for the design of heating policy aiming at reducing long-term carbon emissions, that there is not one single best heating option and also that the importance of the wide systems perspective should be taken into account in policy design. However, our study is limited to the heating sector and its rather straight-forward impact on power sector emissions through alternative use of biomass and built marginal electricity generation. Long-term carbon emissions impacts of more complex interactions between the heating sector and the electricity and transport sectors are disregarded.

Modelling both the consequences of a small additional heat demand in a larger DH system and the combination of small and large-scale plants is difficult. When we developed an integer programming model to avoid the unrealistic solution of investments in very small combined heat and power plants in the DH system, we instead got a flip-flop problem that severely affected the model results.

## Acknowledgment

The study was financed by the Swedish Energy Agency and the multi-partner 4DH project, led by Aalborg University, the J. Gust. Richert Foundation, and the Adlerbertska Research Foundation.

## References

- Åberg, M., 2014. System Effects of Improved Energy Efficiency in Swedish District-Heating Buildings, Engineering Sciences. Uppsala University, Uppsala, Sweden.
- Börjeson, L., Höjer, M., Dreborg, K.-H., Ekvall, T., Finnveden G., 2006. Scenario Types And Techniques: Towards A User's Guide Futures. 38, pp. 723–739.
- Boverket, 2015. Proposal For Swedish Implementation Of Nearly Zero-energy Buildings (Förslag till Svensk Tillämpning av Nära-nollenergieffektivitet) 2015. Karlskrona, Sweden, pp. 26.
- Boverket, 2016. National Board of Housing, Building and Planning works to invite more homes (Boverket arbetar för att fler ska erbjudas bostad). Boverket, Karlskrona, Sweden.
- Christensson, N., Eksta Bostads, A.B., 2015. Kungsbacka, Sweden.
- Dalla Rosa, A., Christensen, J.E., 2011. Low-energy district heating in energy-efficient building areas. Energy 36, 6890–6899.
- Dalla Rosa, A., Li, H., Svendsen, S., Werner, S., Persson, U., Ruehling, K., Felsmann, C., C. M, Burzynski, R., Bevilacqua, C., 2014. Toward 4th Generation District Heating: Experience and Potential of Low-Temperature District Heating, Annex X Final report, IEA DHC/CHP.
- Danish Energy Agency, 2012. Energinet.dk, Individual Heating Plants and Energy Transport, Technology Data for Energy Plants. Danish Energy Agency and Energinet.dk, Copenhagen, Denmark.
- Difs, K., Wetterlund, E., Trygg, L., Söderström, M., 2010. Biomass gasification opportunities in a district heating system. Biomass Bioenergy 34, 637–651.
- Djuric Ilic, D., Trygg, L., 2014. Economic and environmental benefits of converting industrial processes to district heating. Energy Convers. Manag. 87, 305–317.
- EC, 2015a. Eurostat Database. European Commission (EC), Brussels, Belgium.
- EC, 2015b. Climate Action. Paris agreement European Commission, Brussels.
- EMI, 2015. Electricity Network Company—Network fees and annual reports (Elnätsföretag -nättariffer och årsrapporter), Energy Market Inspection (Energimarknadsinspektionen, EMI). Eskilstuna, Sweden.
- ETSAP, 2017. Energy Technology Systems Analysis Program, <http://www.etsap.org>.
- Fahlén, E., Olsson, H., Sandberg, M., Löfås, P., Kilersjö, C., Christensson, N., J. A.P.E., 2014. Vallda Heberg - The largest passive house area in Sweden with renewable energy (Vallda Heberg—Sveriges största passivhusområde med förnybar energi), LÅGAN Report, Gothenburg, Sweden.
- Fishbone, L.G., Abilock, H., 1981. MARKAL A linear programming model for energy systems analysis: technical description of the BNL version. Int. J. Energy Res. 5, 353–375.

- Frederiksen, S., Werner, S., 2013. District Heating and Cooling, 1st ed., Studentlitteratur AB. Lund, Sweden.
- Gargiulo, M., 2009. Getting started with TIMES-VEDA, Version 2.7, Energy Technology Systems Analysis Program (ETSAP).
- GöteborgEnergi, 2014. Environmental Reports [Miljörapporter], Gothenburg, Sweden.
- IEA, 2014. Power Generation in the New Policies and 450 Scenarios. International Energy Agency (IEA), Paris, France.
- Jimmefors, H., Östberg, J., 2014. Energy performance and indoor climate investigations in the passive house residential area Vallda Heberg. Department of Civil and Environmental Engineering, Chalmers University of Technology, Gothenburg, Sweden.
- Karlsson, K.B., Petrovic, S., Næraa, R., 2015. Heat supply planning for the ecological housing community Munksögård. In: Proceedings of the 10th Conference on Sustainable Development of Energy, Water and Environment Systems (SDEWES 2015).
- Li, H., Svendsen, S., 2012. Energy and exergy analysis of low temperature district heating network. *Energy* 45, 237–246.
- Lidberg, T., Olofsson, T., Trygg, L., 2016. System impact of energy efficient building refurbishment within a district heated region. *Energy* 106, 45–53.
- Mahapatra, K., 2015. Energy use and CO<sub>2</sub> emission of new residential buildings built under specific requirements - The case of Växjö municipality. *Sweden Appl. Energy* 152, 31–38.
- Nielsen C.K. Haegermark M. Dalenbäck J.O., 2014. Analysis of a navel solar district heating. In: Proceedings of the EuroSUN 2014 International Solar Energy Society Aix-les-Bains, France.
- Nohlgren, I., Svärd, S.H., Jansson, M., Rodin, J., 2014. Electricity from new and future plants [El från nya och framtida anläggningar]. In: *Elforsk A.B., (Ed.) Swedish Energy Research Centre [Svenska Elföretagens Forsknings- och Utvecklings]*, 14(40), Stockholm, Sweden.
- Pfenninger, S., Hawkes, A., Keirstead, J., 2014. Energy systems modeling for twenty-first century energy challenges. *Renew. Sustain. Energy Rev.* 33, 74–86.
- Sandvall, A.F., Börjesson, M., Ekvall, T., Ahlgren, E.O., 2015. Modelling environmental and energy system impacts of large-scale excess heat utilisation—a regional case study. *Energy* 79, 68–79.
- Sandvall, A.F., Ahlgren, E.O., Ekvall, T., 2016. Cost-efficiency of urban heating strategies - Modelling scale effects of low-energy building heat supply. Manuscript.
- SDH, 2014. Supplied energy (Tillförd energi). Swedish District Heating, Stockholm.
- SEA, 2012. Energy Efficiency Policies and Measures in Sweden. Swedish Energy Agency (SEA), Eskilstuna, Sweden.
- SEA, 2015. Energy in Sweden 2015. Swedish Energy Agency (SEA), Eskilstuna, Sweden.
- Sjödin, J., Grönkvist, S., 2004. Emissions accounting for use and supply of electricity in the Nordic market. *Energy Policy* 32, 1555–1564.
- Statkraft, 2015. Kungsbacka District Heating, <<http://www.statkraft.com/energy-sources/Power-plants/Sweden/Kungsbacka/>> (accessed 20 May 2015).
- Sterman, J.D., 1991. A skeptic's guide to computer models. In: Barney, G.O. (Ed.), *Managing A Nation: The Microcomputer Software Catalog*. Westview Press, Boulder, CO, USA, pp. 209–229.
- Technology Data, 2010. for Energy Plants. Danish Energy Agency and Energinet.dk, Copenhagen, Denmark.
- Technology Data, 2012. for Energy Plants- Generation of Electricity and District Heating, Energy Storage and Energy Carrier Generation and Conversion. Danish Energy Agency and Energinet.dk, Copenhagen, Denmark.
- TekniskaVerken, 2014. Environmental Reports [Miljörapporter], Linköping, Sweden.
- UN, 2014. World Urbanization Prospects: The 2014 Revision Highlights (ST/ESA/SER.A/352), United Nations, Department of Economic and Social Affairs, Population Division.
- Valik, J., Petersson, A., 2015. Boverket's mandatory provisions on the amendment to the Board's building regulations (2011:6) –mandatory provisions and general recommendations (Boverkets föreskrifter om ändring i verkets byggregler (2011:6) – föreskrifter och allmänna råd, Boverkets författningssamling, Boverket, Sweden.
- Voort, E., v.d., Donni, E., Thonet, C., Bois d'Enghien, E., Dechamps, C., Guilmot, J.F., 1984. Energy Supply Modelling Package EFOM-12C Mark I, Mathematical description, EUR-8896, Commission of the European Communities. Louvain-la-Neuve, Cabay, France.
- World Energy Outlook, 2013. International Energy Agency (IEA), Paris, France.