



W-band spatial power combiner and splitter in gap waveguide technology

Downloaded from: <https://research.chalmers.se>, 2026-04-06 08:56 UTC

Citation for the original published paper (version of record):

Shah, W., Maaskant, R., Uz Zaman, A. et al (2016). W-band spatial power combiner and splitter in gap waveguide technology. 2016 IEEE Antennas and Propagation Society International Symposium, APSURSI 2016, Fajardo, Puerto Rico, 26 June - 1 July 2016: 255-256.
<http://dx.doi.org/10.1109/APS.2016.7695836>

N.B. When citing this work, cite the original published paper.

© 2016 IEEE. Personal use of this material is permitted. Permission from IEEE must be obtained for all other uses, in any current or future media, including reprinting/republishing this material for advertising or promotional purposes, or reuse of any copyrighted component of this work in other works.

W-band Spatial Power Combiner and Splitter in Gap Waveguide Technology

Waqar Ali Shah, Rob Maaskant, Ashraf Uz Zaman, Marianna Ivashina, and Per-Simon Kildal

Antenna Group, Department of Signals and Systems,
Chalmers University of Technology, Gothenburg, Sweden
waqaral@student.chalmers.se, rob.maaskant@chalmers.se, zaman@chalmers.se,
marianna.ivashina@chalmers.se, per-simon.kildal@chalmers.se

Abstract—A passive power splitter and combiner has been designed in-between two metallic ground plates using gap waveguide technology. The measured insertion loss is smaller than 2.3 dB and the return loss is larger than 10 dB over the entire W-band (75-110 GHz). The design procedure has been detailed and the simulated and measured results for the proposed structure are shown. The designed structure can be used as a passive power splitter or combiner, as a grid amplifier in a back-to-back RF chain, or as a quasi-optical beamforming component in beam steering antenna arrays.

Keywords—Gap waveguide technology; spatial power combiner; grid amplifiers.

I. INTRODUCTION

The demand to develop low loss and packaged mm-wave structures capable of delivering a significant amount of power is increasing. However, there are several challenges that must be overcome when moving up in frequency. Firstly, the insertion loss of splitters and combiner using transmission lines that are based on printed circuit board (PCB) technology increases due to both dielectric and conductor losses; the total Ohmic loss increases as the number of channels increases, see e.g. [1]. We propose to employ a novel metamaterial-based gap waveguide concept as considered in this paper, which is a low-loss dielectric-free transmission line structure [2]. Secondly, large size power splitter components give rise to cavity resonances at higher frequencies due to discontinuities at junctions and bends. These spurious modes can be removed with the aid gap waveguide packaging, as e.g. shown for series-fed amplifiers [3]. The gap waveguide technology is therefore a prime candidate to split and combine power in low loss air dielectrics and package it as a resonance-free structure [4], [5].

We have designed and measured a single layer parallel plate spatial power combiner. The proposed design forms the basis of several passive and active RF components that will be developed in future, including spatially beamformed antenna arrays [6] as well as grid amplifiers.

II. THE PROPOSED BACK-TO-BACK STRUCTURE

The proposed Back-to-Back (B2B) design is shown in Fig. 1. The structure is fed by a WR-10 rectangular waveguide to excite the horn antenna I. The horn illuminates a wall of gap waveguide pins representing an offset parabolic reflector,

similar to II, but on the opposite side (not visible). The planar wavefront emanating from the reflector is then incident on an array of ridge gap waveguides (III). The ridges are separated by gap waveguide pins creating a stop band – thus blocking all modes. This increases the ridge-to-ridge isolation (~ 20 dB per pin row), which is not the case when employing rectangular waveguides made of H-plane split blocks that can leak laterally. The field distributions in Fig. 2 further exemplify the operation principle.

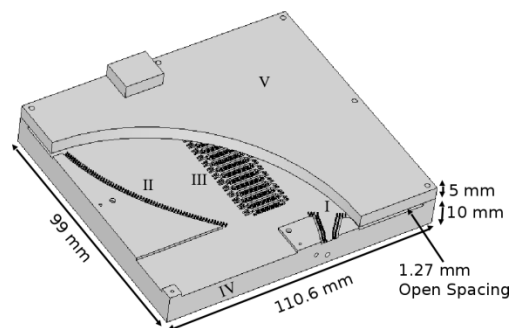

Fig. 1. The single layer B2B prototype. I: horn antenna; II: parabolically-shaped reflecting pin wall; III: array of ridge gap waveguides; IV and V: bottom and top block forming the parallel-plate waveguide region.

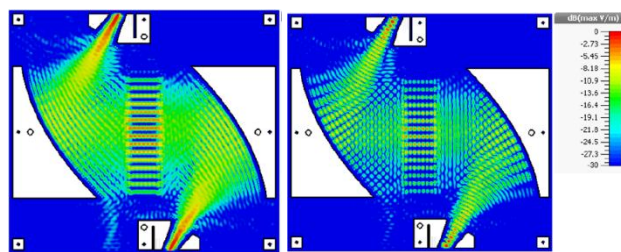

Fig. 2. (Left) Time-averaged E-field amplitude, and; (Right) instantaneous field @80 GHz inside the parallel-plate waveguide structure.

III. DESIGN STEPS

For W-band operation, the first step is to design a bed of nails exhibiting a stop band for this frequency range [7], [8], [9]. Fig. 3 shows the computed dispersion diagram of a single pin inside a unit cell employing periodic boundary conditions (CST software is used). No modes are seen to be present in the band from 70–140 GHz. The gap waveguide pin dimensions are $L = W = 0.3$ mm, $H = 0.81$ mm, and $S = 0.19$ mm. The pin period is 0.9 mm.

Next, the horn (I) and offset parabolic reflecting wall (II) are designed in gap waveguide technology with parameters (in mm): Diameter of offset reflector = 55; $\Theta_s/2 = 36.3^\circ$; Offset height = 10, and; Focal length = 32.5. Hence, $F/D = 0.59$.

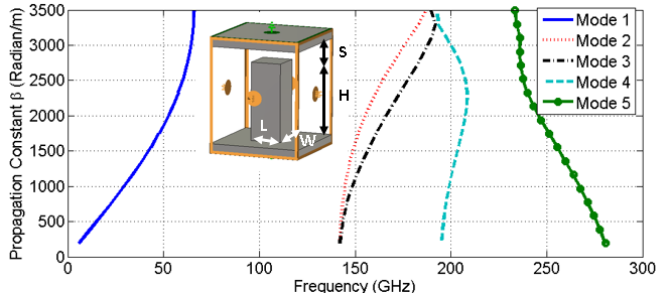

Fig. 3. Dispersion diagram of a gap waveguide pin showing the stop band.

Accordingly, a transition is designed to move from a planar wave front of the parallel-plate waveguide field emanating from the reflector aperture to an array of ridge gap waveguides, i.e., the center section in Figs. 1 and 2. Fig. 4 is a close-up of the designed transition. A fork-type transition is needed to transfer the quasi-optically beamformed parallel plate waveguide field to the array of ridge gap waveguides.

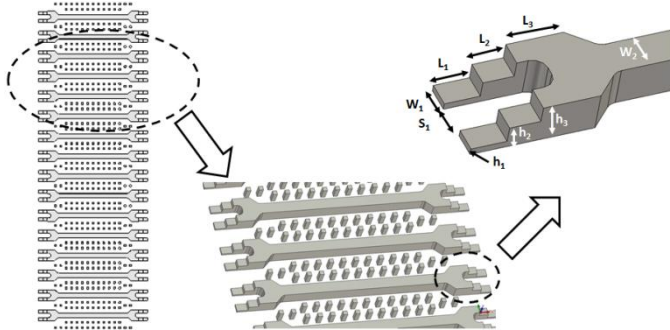

Fig. 4. The fork structure as a transition from parallel-plate waveguide fields to an array of ridge gap waveguides with (in mm) $L_1 = 0.7821$; $L_2 = 0.68$; $L_3 = 1.25$; $h_1 = 0.15$; $h_2 = 0.52$; $h_3 = 0.89$; $W_1 = 0.537$; $W_2 = 0.774$, and; $S_1 = 0.774$.

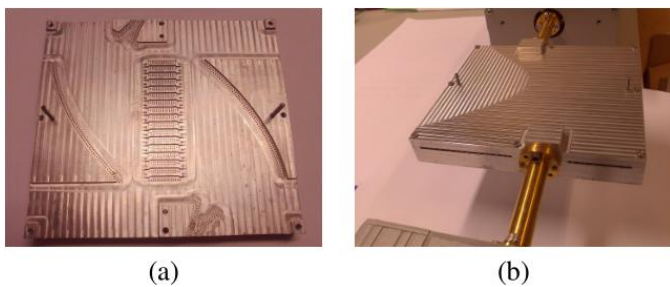

Fig. 5. (a) View of the inside of the milled prototype. (b) Measurement setup.

IV. MEASUREMENT RESULTS

An aluminum prototype was milled and designed such as to sustain a 5-10 μm RMS tolerance. It was measured by a VNA using standard WR-10 rectangular waveguide flanges, as shown in Fig. 5. The measured S_{11} remains below -10 dB over the entire W-band, but the S_{21} degraded to -2.28 dB (-1.1 dB for half of the structure, no surface treatment). This loss is partly attributed to the surface roughness, as also the simulation

indicates, where the S_{21} is seen to degrade from -0.65 dB (PEC materials) to -1.67 dB (for 15 μm surface roughness).

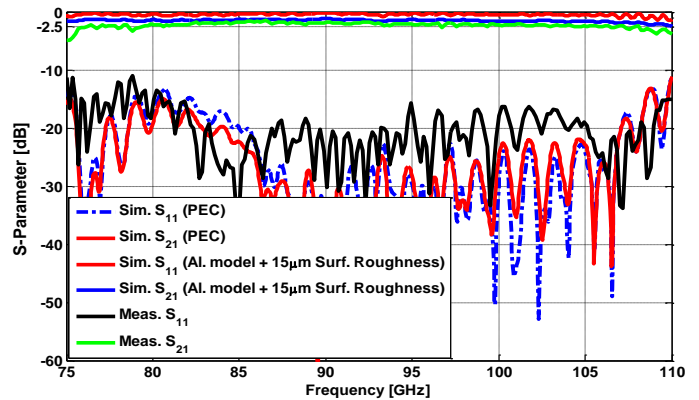

Fig. 6. Measured and simulated S-parameter results for the B2B structure.

V. CONCLUSIONS

The milled Aluminum 16-channel back-to-back gap waveguide spatial power splitter and combiner has an overall return loss larger than 10 dB and an insertion loss smaller than 2.28 dB over the entire W-band (75–110 GHz). A fork-type transition is needed to transfer the planar wavefront originating from the reflector aperture to the array of ridge gap waveguides. The novel dielectric-free structure can be used as a standalone power splitter and/or combiner, a beamformer to excite an array of slot antennas in the top ground plane by ridge gap waveguides, or as a back-to-back structure for the design of planar grid amplifiers. Future work will be focusing toward these applications.

REFERENCES

- [1] M. P. DeLisio and R. A. York, "Quasi-optical and spatial power combining," *IEEE Trans. Microw. Theory Tech.*, vol. 50, no. 3, pp. 929–936, Mar. 2002.
- [2] A. U. Zaman and P.-S. Kildal, "Wide-band slot antenna arrays with single layer corporate-feed network in ridge gap waveguide technology," *IEEE Trans. Antennas Propag.*, vol. 62, no. 6, pp. 2992–3001, Jun. 2014.
- [3] A.U. Zaman, T. Vukusic, M. Alexanderson, P.-S. Kildal, "Gap Waveguide PMC Packaging for Improved Isolation of Circuit Components in High Frequency Microwave Modules," *IEEE Transactions on Components, Packaging and Manufacturing Technology*, Vol. 4, Issue 1, p. 16 – 25, 2014.
- [4] P.-S. Kildal, E. Alfonso, A. Valero-Nogueira, and E. Rajo-Iglesias, "Local metamaterial-based waveguides in gaps between parallel metal plates," *IEEE Antennas Wireless Propag. Lett.*, vol. 8, no. 1, pp. 84–87, 2009.
- [5] A. Valero-Nogueira, E. Alfonso, J. I. Herranz, and P.-S. Kildal, "Experimental demonstration of local quasi-TEM gap modes in single hard-wall waveguides," *IEEE Microw. Wireless Compon. Lett.*, vol. 19, pp. 536–538, 2009.
- [6] E. Gandini, M. Ettore, M. Caseletti, K. Tekkouk, L. L. Coq, and R. Sauleau, "SIW slotted waveguide array with pillbox transition for mechanical beam scanning," *IEEE Antennas Wireless Propag. Lett.*, vol. 11, pp. 1572–1575, 2012.
- [7] P.-S. Kildal and A. Kishk, "EM modeling of Surfaces with STOP or GO characteristics-artificial magnetic conductors and soft and hard surfaces," *ACES Journal*, vol. 18, pp. 32–40, Mar. 2003.
- [8] P. -S. Kildal, "Three metamaterial-based gap waveguides between parallel metal plates for mm/submm waves", *Proc. 3rd Eur. Conf. Antennas Propag.*, pp. 28–32, Mar. 2009.
- [9] E. Rajo-Iglesias and P.-S. Kildal, "Numerical studies of bandwidth of parallel-plate cut-off realised by a bed of nails, corrugations and mushroom-type electromagnetic bandgap for use in gap waveguides," *IET Microwaves, Antennas & Propagation*, vol. 5, no. 3, pp. 282–289, 2011.