

CHALMERS



RADIAL HEAT FLOW FOR A PIPE IN A BOREHOLE IN GROUND USING LAPLACE SOLUTIONS. REPORT ON MATHEMATICAL BACKGROUND

JOHAN CLAESSION

RADIAL HEAT FLOW FOR A PIPE IN A BOREHOLE IN GROUND USING LAPLACE SOLUTIONS.
REPORT ON MATHEMATICAL BACKGROUND

JOHAN CLAEISSON

©JOHAN CLAEISSON, 2011
REPORT NO. 2011:4, ISSN 1652-9162
Department of Civil and Environmental Engineering
Division of Building Technology/Building Physics
CHALMERS UNIVERSITY OF TECHNOLOGY
SE-412 96 Göteborg
Sweden
Telephone +46 (0)31 772 1996

Contents

1	Considered step-response problems	5
2	Mathematical problem for a pipe in ground	8
3	The problem for the Laplace transforms	9
4	Solution for the Laplace transform.....	10
4.1	Basic solution	10
4.2	Ground thermal resistance.....	11
4.3	Thermal resistance network	12
4.4	Approximations for short and long times.....	13
5	Inversion of Laplace transforms.....	14
5.1	General formula for radial problems	14
5.2	Inversion formulas for a pipe in ground.....	16
6	Pipe, borehole annulus and ground	17
6.1	Mathematical problem for a pipe in a borehole in ground.....	17
6.2	Relations for an annular region	18
6.3	The whole thermal network.....	19
6.4	Pipe fluid temperature	20
6.5	Laplace transforms for the other quantities.....	22
6.6	Approximations for short and long times.....	22
7	Dimensionless form.....	23
7.1	Pipe in ground	23
7.2	Laplace transform and thermal network.....	24
8	Numerical solution	26
8.1	Radial heat equation	26
8.2	Steady-state solution, radial thermal resistance	27
8.3	Coordinate transformation using the radial thermal resistance	28
8.4	Equations in discretized form.....	28
8.5	Pipe in borehole in ground	30
8.6	Equations for a pipe in borehole in ground	31
8.7	Summary of formulas for a pipe in borehole in ground.....	33
8.8	Formulas for pipe in ground.....	35
	References	36

Appendix 1. Formulas for inversion of the Laplace transform	37
A1.1 Inversion formula	37
A1.2 A better integration path in the complex plane	38
A1.3 Integration around $s = 0$	39
A1.4 Inversion integral for the time derivative	40
A1.5 Time integration to obtain $f(t)$	42
Appendix 2. Formulas for an annular region	43
Appendix 3. Bessel functions	47
Appendix 4 Solutions and studies in Mathcad	49
A4.1 Laplace solution for $T_f(t)$ for a pipe in borehole in ground	49
A4.2 Numerical solution for $T_f(t)$ for a pipe in borehole in ground	49
A4.3 Comparison of Laplace and numerical solution	50
A4.4 Studies and comparisons in the Laplace domain	51
A4.5 Pipe in ground	52
A4.6 Comparison of pipe and borehole solutions	52
A4.7 Bessel functions	52
Mathcad file: Laplace solution for $T_f(t)$ for a pipe in borehole in ground	53
Mathcad file: Numerical solution for $T_f(t)$ for a pipe in borehole in ground	61
Mathcad file: Comparison of Laplace and numerical solution	70
Mathcad file: Studies and comparisons in the Laplace domain	82
Mathcad file: Pipe in ground	89
Mathcad file: Comparison of pipe and borehole solutions	94
Mathcad file: Bessel functions	97

1 Considered step-response problems

The ground, soil or rock, may be used as a heat source or sink for heating or cooling of buildings. A borehole with an inserted plastic U-pipe for the heat carrier fluid may be used as ground heat exchanger. The region between the borehole wall and the pipe is filled with grout. The basic question is what fluid temperatures $T_f(t)$ that are required in order to obtain any prescribed heat injection $Q_{inj}(t)$ (W). By definition, $Q_{inj}(t)$ is negative when heat is extracted from the ground.

The injection/extraction of heat causes a thermal process in borehole and ground that is superimposed on the undisturbed temperatures in the ground. Here we only study the superimposed process due to heat injection/extraction. This means that the undisturbed initial ground and borehole temperature is zero, and that the fluid temperature $T_f(t)$ is the excess temperature above undisturbed ground conditions.

The U-pipe is in this study replaced by a *single* equivalent central pipe in the borehole. This key simplification means that we have a radial thermal process in the plane perpendicular to the borehole axis. Adjacent boreholes may disturb the radial process after a certain number of days. Three-dimensional thermal effects will by and by influence the temperature field starting at the top and bottom of the borehole. Here, we do not consider other boreholes and axial heat flow. Our radial solutions are valid during a first period of at least a few days. A precise analysis for this first period is crucial when the borehole heat exchanger is used for both injection and extraction on a daily basis.

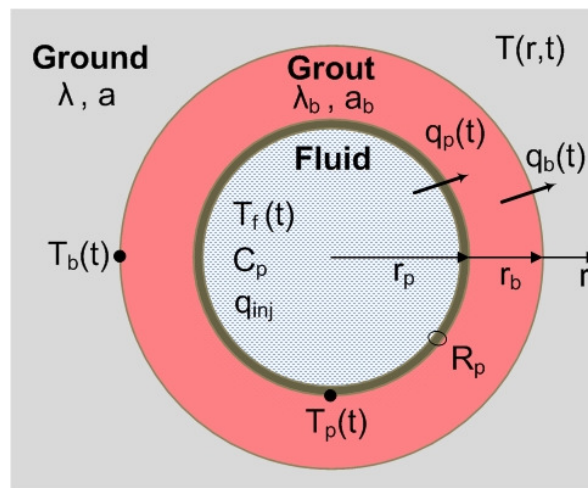

Figure 1.1 Step-response problem for a pipe in an annular borehole region in the ground.

Figure 1.1 shows the considered thermal problem. The heat carrier fluid in the equivalent pipe has the temperature $T_f(t)$. The heat capacity of the fluid in the pipe is C_p (J/(K,m)).

There is a thermal resistance R_p ((K,m)/W) (per unit pipe length) at the pipe wall. The annular grout region and the ground outside the borehole have in general different thermal properties. The fluid, grout and ground have zero initial temperature. The fluid is heated with a constant heat injection rate q_{inj} (W/m) for $t > 0$. This is the key step-response problem that is solved here. We are in particular interested in the fluid step-response temperature $T_f(t) = T_{step}(t)$ for unit heat injection $q_{inj} = 1$. This is the required fluid temperature to obtain the heat flux +1 from the initial time $t=0$.

The backfill or grout may have the same thermal properties as the ground. Figure shows this simpler case of step-response for a pipe in ground.

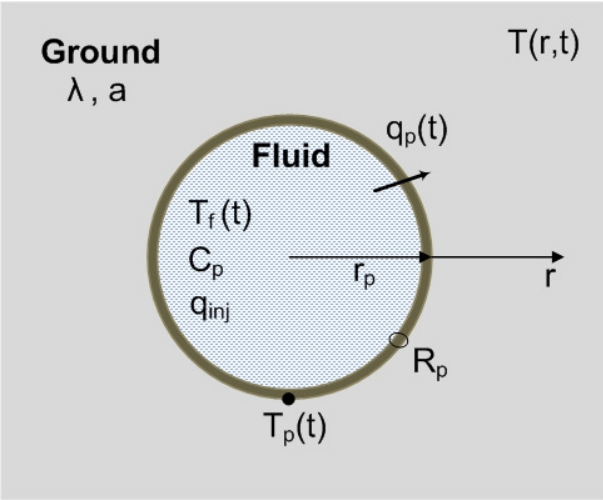

Figure 1.2 The simpler step-response problem for a pipe in the ground.

The key tool of analysis of the thermal performance of borehole heat exchangers is these so-called step-response functions. Figures 1.3-4 illustrate the reason for this.

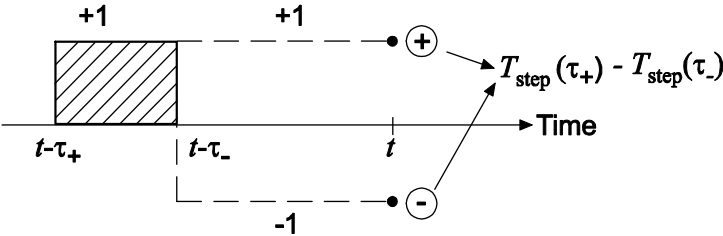

Figure 1.3 Temperature response after a unit heat-injection pulse using superposition.

Consider a unit heat-injection pulse from $t - \tau_+$ to $t - \tau_-$. The required fluid temperature at time t is obtained by superposition of a step +1 from $t - \tau_+$ and a negative step -1 from $t - \tau_-$ as indicated in Figure 1.3. The required fluid temperature is then $T_f(t) = T_{\text{step}}(\tau_+) - T_{\text{step}}(\tau_-)$. The positive step is to be taken for $t - (t - \tau_+) = \tau_+$ and the negative one for $t - (t - \tau_-) = \tau_-$.

Consider now any sequence of piecewise constant heat-injection rates q_n up to the time t , Figure 1.4. Pulse n precedes the considered time t and lies between $t - \tau_n$ to $t - \tau_{n-1}$. Here, τ_n is any increasing time series starting from zero: $\tau_0 = 0$, $\tau_{n-1} < \tau_n$. Any number of preceding pulses may be used.

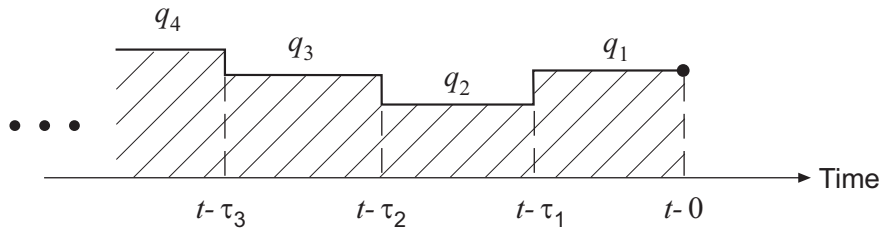

Figure 1.4 A sequence of piecewise constant heat-injection rates up to the considered time t .

The required fluid temperature is now obtained by superposition of pulse responses of the type illustrated in Figure 1.3. We have for N preceding pulses:

$$T_f(t) = \sum_{n=1}^N q_n \cdot [T_{\text{step}}(\tau_n) - T_{\text{step}}(\tau_{n-1})], \quad \tau_n > \tau_{n-1}, \quad T_{\text{step}}(\tau_0) = T_{\text{step}}(0) = 0. \quad (1.1)$$

This basic formula shows the importance of the step-response function. The difference $T_{\text{step}}(\tau_n) - T_{\text{step}}(\tau_{n-1})$ over a time interval $\tau_{n-1} < \tau < \tau_n$ is the *weighting factor* for the constant injection rate q_n over a preceding time interval from $t - \tau_n$ to $t - \tau_{n-1}$.

The results of this report are presented in a paper by Javed and Claesson, 2011. This report presents the full mathematical derivations. All solutions have been implemented in the mathematical computer program Mathcad. Seven appended calculation sheets are briefly presented in Appendix 4. Here, the solutions are studied and compared in various ways. The comparison of the fluid temperature $T_f(t)$ from the analytical Laplace solution and the numerical solution is presented in A4.3. The differences are typically of the order 0.003 K or smaller, which means the both types of solution presented in this report are indeed correct.

2 Mathematical problem for a pipe in ground

The temperature $T(r,t)$ in the ground outside a pipe with the r_p radius shall satisfy the *radial* heat conduction equation in the two-dimensional infinite plane perpendicular to the pipe axis:

$$\frac{1}{a} \cdot \frac{\partial T}{\partial t} = \nabla^2 T = \frac{\partial^2 T}{\partial r^2} + \frac{1}{r} \cdot \frac{\partial T}{\partial r}, \quad r_p \leq r < \infty. \quad (2.1)$$

Here, r is the radial distance to the center of the pipe, t time, $a = \lambda / (\rho c)$ (m^2/s) the thermal diffusivity of the ground (soil or rock) outside the pipe, λ ($\text{W}/(\text{K}\cdot\text{m})$) the thermal conductivity, ρ (kg/m^3) the density and c ($\text{J}/(\text{K}\cdot\text{kg})$) the heat capacity. The radial heat flux in the ground outside the pipe (W/m) is:

$$q(r,t) = 2\pi r \cdot (-\lambda) \cdot \frac{\partial T}{\partial r}. \quad (2.2)$$

The pipe is filled with water or another heat carrier fluid with the temperature $T_f(t)$. There is a thermal resistance R_p ($(\text{K}\cdot\text{m})/\text{W}$) (per unit pipe length) over the pipe periphery from the fluid in the pipe to the ground just outside the pipe. It includes the plastic pipe wall and the fluid boundary layer. The heat flux over this thermal resistance is equal to the radial heat flux in the ground just outside the pipe. The corresponding thermal conductance is $K_p = 1/R_p$ ($\text{W}/(\text{m}\cdot\text{K})$). The boundary condition at the pipe, $r = r_p$, is then:

$$T_f(t) - T(r_p, t) = R_p \cdot q(r_p, t). \quad (2.3)$$

We will use both thermal resistance R ($(\text{K}\cdot\text{m})/\text{W}$) and the corresponding thermal conductance $K = 1/R$ ($\text{W}/(\text{m}\cdot\text{K})$) throughout this study.

The heat injection to the fluid in the pipe is q_{inj} (W/m). The heat balance for the fluid in the pipe becomes:

$$q_{\text{inj}} = C_p \cdot \frac{dT_f}{dt} + q(r_p, t), \quad t > 0; \quad C_p = \pi r_p^2 \cdot \rho_f c_f. \quad (2.4)$$

Here, C_p ($\text{J}/(\text{K}\cdot\text{m})$) is the heat capacity of the fluid in the pipe, ρ_f (kg/m^3) the density and c_f ($\text{J}/(\text{kg}\cdot\text{K})$) the heat capacity of the fluid. The initial temperature in the pipe fluid and the ground is zero for the considered thermal response for the step heat input to the fluid in the pipe:

$$T_f(0) = 0, \quad T(r, 0) = 0, \quad r > r_p. \quad (2.5)$$

The equations (2.1)-(2.5) define the considered thermal response problem. The primary input data are:

$$r_p, \lambda, a = \frac{\lambda}{\rho c}, q_{inj}, R_p = \frac{1}{K_p}, C_p. \quad (2.6)$$

The solution to the above problem is given in the reference work of Carslaw-Jaeger, 1959 (Sections 13.5-6.). The new thing in this presentation is the introduction of a *thermal network* for the Laplace transform of the solution. The formulas in Carslaw-Jaeger tend to be rather complicated. The solutions can in the network formulation be presented in a more compact way, which hopefully contributes to a better understanding of the structure of the solutions.

It should be noted that the resistance $R_p = 1/K_p$ is the sum of the thermal resistance of the pipe wall (an annulus) and the fluid boundary layer:

$$R_p = \frac{1}{K_p} = \frac{1}{2\pi\lambda_p} \cdot \ln\left(\frac{r_p}{r_p - d_{pw}}\right) + \frac{1}{2r_p \cdot h_p}. \quad (2.7)$$

Formulas for the convective heat transfer coefficient h_p may be found in Rohsenow et al. 1985. A detailed discussion is given in Hellström 1991. Here, λ_p (W/(K,m)) the thermal conductivity and d_{pw} the thickness of the pipe wall. The boundary heat transfer coefficient h_p (W/(K,m²)) (from bulk fluid to solid wall surface) involves the pipe diameter $2r_p$ as length factor.

3 The problem for the Laplace transforms

The Laplace transforms of the fluid temperature $T_f(t)$ and the ground temperature $T(r,t)$ are given by:

$$\bar{T}_f(s) = \int_0^{\infty} e^{-s \cdot t} \cdot T_f(t) dt, \quad \bar{T}(r,s) = \int_0^{\infty} e^{-s \cdot t} \cdot T(r,t) dt. \quad (3.1)$$

Here, s is a complex-valued parameter or variable with the dimension 1/time so that $s \cdot t$ is dimensionless.

The Laplace transform of the heat equation (2.1) becomes:

$$\frac{\partial^2 \bar{T}}{\partial r^2} + \frac{1}{r} \cdot \frac{\partial \bar{T}}{\partial r} = \frac{s}{a} \cdot \bar{T}(r,s), \quad r_p \leq r < \infty. \quad (3.2)$$

Here, we use the fact that the ground temperature is zero at $t=0$. The time derivative corresponds to multiplication by s in the Laplace transform. We introduce special notations for the temperature and heat flux in the soil (or rock) at the outside of the pipe:

$$\bar{T}_p(s) = \bar{T}(r_p, s), \quad \bar{q}_p(s) = \bar{q}(r_p, s). \quad (3.3)$$

The Laplace transforms of radial heat flux (2.2) in the outside ground and at the pipe become:

$$\bar{q}(r, s) = 2\pi r \cdot (-\lambda) \cdot \frac{\partial \bar{T}}{\partial r}, \quad \bar{q}_p(s) = 2\pi r_p \cdot (-\lambda) \cdot \frac{\partial \bar{T}}{\partial r} \Big|_{r=r_p}. \quad (3.4)$$

The boundary condition (2.3) at the pipe becomes:

$$\bar{T}_f(s) - \bar{T}_p(s) = R_p \cdot \bar{q}_p(s). \quad (3.5)$$

The heat balance (2.4) for the water in the pipe becomes, since the Laplace transform of the constant q_{inj} is q_{inj}/s :

$$\frac{q_{inj}}{s} = C_p \cdot s \cdot \bar{T}_f(s) + \bar{q}_p(s). \quad (3.6)$$

The equations (3.2)-(3.6) define the thermal problem for the Laplace transforms. This is the problem to solve in the Laplace domain. The equations are to be solved for any value of the Laplace parameter s , which may assume any real or complex value. The time derivatives are replaced by multiplication by s . It should be noted that in the fluid and ground temperatures are zero at the initial time $t = 0$.

4 Solution for the Laplace transform

The solution to equations (3.2)-(3.6) is presented in this section.

4.1 Basic solution

The first step is to find solutions to the differential equation (3.2). The parameter s occurs in right-hand factor s/a ($1/m^2$) only. We may scale r with $\sqrt{s/a}$ in the two terms on the left-hand side:

$$\bar{T}(r, s) = g(z), \quad z = r \cdot \sqrt{s/a} \quad \Rightarrow \quad \frac{d^2 g}{dz^2} + \frac{1}{z} \cdot \frac{dg}{dz} - g(z) = 0. \quad (4.1)$$

This is the differential equation for modified Bessel functions (of order zero). The reference Handbook of Mathematical Functions by Abramowitz, Stegun 1964, (Section 9.6), gives a good presentation of Bessel functions. There are two independent solutions, modified Bessel functions of zero order. The Bessel functions, and relations for these used here, are presented in Appendix 3. We have the following general solution to (3.2):

$$g(z) = \bar{T}(r, s) = A(s) \cdot I_0(z) + B(s) \cdot K_0(z), \quad z = r \sqrt{s/a}. \quad (4.2)$$

The coefficients A and B are any functions of the parameter s . The function $I_0(z)$ is regular at $z = 0$ and increases exponentially with z , while the function $K_0(z)$ is infinite at $z = 0$ and decreases exponentially with z . The coefficient before $I_0(z)$ must be zero in our case since the radius extends to infinity. The general solution outside the pipe is then using (3.3):

$$\bar{T}(r, s) = \frac{K_0(r\sqrt{s/a})}{K_0(r_p\sqrt{s/a})} \cdot \bar{T}_p(s), \quad r_p \leq r < \infty. \quad (4.3)$$

4.2 Ground thermal resistance

The heat flux (3.4), right, becomes using (4.3):

$$\bar{q}_p(s) = 2\pi r_p \cdot (-\lambda) \cdot \left. \frac{\partial \bar{T}}{\partial r} \right|_{r=r_p} = 2\pi r_p \cdot (-\lambda) \cdot \frac{\sqrt{s/a} \cdot K'_0(r_p\sqrt{s/a})}{K_0(r_p\sqrt{s/a})} \cdot \bar{T}_p(s). \quad (4.4)$$

From Abramowitz-Stegun, we have the derivative: $K'_0(z) = -K_1(z)$. Here, $K_1(z)$ is a modified Bessel function of the first order. In the Laplace transform of the thermal process in the ground, $r_p \leq r < \infty$, the relation between the boundary flux and temperature at $r = r_p$ is given by a *thermal resistance* (W/(m,K)):

$$\bar{T}_p(s) - 0 = \bar{R}_g(s) \cdot \bar{q}_p(s), \quad \bar{R}_g(s) = \frac{1}{\bar{K}_g(s)} = \frac{1}{2\pi\lambda} \cdot \frac{K_0(r_p\sqrt{s/a})}{r_p\sqrt{s/a} \cdot K_1(r_p\sqrt{s/a})}. \quad (4.5)$$

The ground thermal conductance and its inverse, the thermal resistance, are functions of the complex-valued parameter s . The temperature difference between the ground at the pipe and at infinity with zero initial ground temperature is equal to a resistance times the heat flux at the pipe.

The square root $r_p\sqrt{s/a}$ occurs frequently in the formulas above. We introduce the new notation

$$\sigma_g = r_p\sqrt{s/a} = \sqrt{t_p s}, \quad t_p = r_p^2/a. \quad (4.6)$$

The ground thermal resistance may be written in the following way:

$$\bar{R}_g(s) = \frac{1}{\bar{K}_g(s)} = \frac{1}{2\pi\lambda} \cdot \frac{K_0(\sigma_g)}{\sigma_g \cdot K_1(\sigma_g)}, \quad \sigma_g = r_p\sqrt{s/a} = \sqrt{t_p s}. \quad (4.7)$$

We are in particular interested in the case when s lies on the *negative real axis*:

$$\Gamma: \quad t_p s = -u^2 + i \cdot 0, \quad 0 < u < \infty; \quad \sigma_g = \sqrt{t_p s} = i \cdot u. \quad (4.8)$$

See Figures A1.1-2. Here, the notation $+i \cdot 0$ indicates that the negative real axis is approached from above in the complex s -plane as discussed and described in Appendix 1. From formula (11.7) in Appendix 3 for Bessel functions we have for s on the negative real axis (approached from the upper side):

$$2\pi\lambda \cdot \bar{R}_g(s) \Big|_{\Gamma} = \frac{K_0(\sigma_g)}{\sigma_g \cdot K_1(\sigma_g)} \Big|_{\Gamma} = \frac{K_0(iu)}{iu \cdot K_1(iu)} = \frac{J_0(u) - i \cdot Y_0(u)}{u \cdot [J_1(u) - i \cdot Y_1(u)]}, \quad u > 0. \quad (4.9)$$

Here, $J_n(z)$ and $Y_n(z)$ are ordinary Bessel functions of order n .

4.3 Thermal resistance network

The solution is now given by the three equations (3.6), (3.5) and (4.5):

$$\frac{q_{inj}}{s} = C_p s \cdot \bar{T}_f(s) + \bar{q}_p(s) = \frac{\bar{T}_f(s) - 0}{1/(C_p s)} + \bar{q}_p(s). \quad (4.10)$$

$$\bar{T}_f(s) - \bar{T}_p(s) = R_p \cdot \bar{q}_p(s). \quad (4.11)$$

$$\bar{T}_p(s) - 0 = \bar{R}_g(s) \cdot \bar{q}_p(s). \quad (4.12)$$

The full solution is readily obtained from this linear equation system with the three unknowns $\bar{T}_f(s)$, $\bar{T}_p(s)$ and $\bar{q}_p(s)$. The three equations may be represented by a *thermal network* for the *Laplace transform* of the solution. See Figure 4.1.

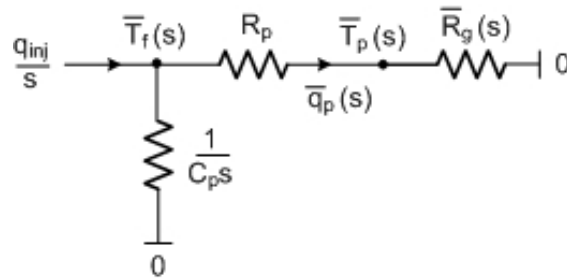

Figure 4.1 Thermal network for the Laplace transforms for a pipe in ground, (4.10)-(4.12).

Let us illustrate the effectiveness of the graphical representation. From (4.11) and (4.12) we get the relation between \bar{T}_f and \bar{T}_p :

$$\frac{\bar{T}_f(s) - \bar{T}_p(s)}{R_p} = \frac{\bar{T}_p(s) - 0}{\bar{R}_g(s)}, \quad \bar{T}_p = \frac{\bar{R}_g(s)}{R_p + \bar{R}_g(s)} \cdot \bar{T}_f(s). \quad (4.13)$$

Combining (4.12) and (4.13), we have:

$$\bar{q}_p(s) = \frac{1}{\bar{R}_g(s)} \cdot \bar{T}_p(s) = \frac{\bar{T}_f(s)}{R_p + \bar{R}_g(s)}. \quad (4.14)$$

And from (4.10) and (4.14) we get:

$$\frac{q_{inj}}{s} = C_p \cdot s \cdot \bar{T}_f(s) + \frac{\bar{T}_f(s)}{R_p + \bar{R}_g(s)} = \left[C_p \cdot s + \frac{1}{R_p + \bar{R}_g(s)} \right] \cdot \bar{T}_f(s). \quad (4.15)$$

The complete solution is now:

$$\bar{T}_f(s) = \frac{q_{inj}}{s} \cdot \frac{1}{C_p \cdot s + \frac{1}{R_p + \bar{R}_g(s)}}. \quad (4.16)$$

$$\bar{T}_p(s) = \frac{\bar{R}_g(s) \cdot \bar{T}_f(s)}{R_p + \bar{R}_g(s)}, \quad \bar{q}_p(s) = \bar{K}_g(s) \cdot \bar{T}_p(s). \quad (4.17)$$

$$\bar{T}(r, s) = \bar{T}_p(s) \cdot \frac{K_0(\sigma_g \cdot r / r_p)}{K_0(\sigma_g)}, \quad 1 \leq r / r_p < \infty. \quad (4.18)$$

In the last formula, Equation (4.3) is used. The nice thing with this thermal network, which is a graphical representation of the equations (4.10)-(4.12), is that we can use well known rules from ordinary thermal or electric networks. The pipe temperature (4.16) is directly obtained by adding thermal resistances in series and in parallel. The resistances R_p and $\bar{R}_g(s)$ lie in series and are added. The conductance $C_p \cdot s$ lies in parallel with the conductance $1/(R_p + \bar{R}_g(s))$. The inverse of the sum of these two conductances is the resistance to the right of the node for the fluid temperature.

4.4 Approximations for short and long times

Let us first consider the behavior for short times. The heat flux over the pipe wall is zero for $t=0$. The water temperature in the pipe increases linearly for very short times:

$$q(r_p, 0) = 0 \Rightarrow \frac{dT_f}{dt}(0) = \frac{q_{inj}}{C_p}; \quad T_f(t) \approx \frac{q_{inj}}{C_p} \cdot t. \quad (4.19)$$

The next approximation is to neglect the temperature increase outside the pipe wall. We get a simple exponential solution:

$$T(r_p, t) \approx 0: \quad q_{\text{inj}} \approx C_p \cdot \frac{dT_f}{dt} + \frac{T_f(t) - 0}{R_p}, \quad T_f(0) = 0 \Rightarrow \quad (4.20)$$

$$T_f(t) \approx q_{\text{inj}} \cdot R_p \left(1 - e^{-t/(C_p \cdot R_p)}\right).$$

For large times, we may use the well known line-source solution from Carslaw-Jaeger, pp.261-262. The temperature solution for a constant heat injection at $r=0$ from time $t=0$ is given by the exponential integral:

$$T_{\text{ls}}(r, t) = \frac{q_{\text{inj}}}{4\pi\lambda} \cdot E_1\left(\frac{r^2}{4at}\right) \Rightarrow T_f(t) \approx T_{\text{ls}}(r_p, t) + q_{\text{inj}} \cdot R_p. \quad (4.21)$$

In the approximation, we take the line-source solution at $r=r_p$. The temperature difference over the pipe wall, q_{inj} times the wall resistance R_p , is added to give the right-hand expression. The exponential integral is defined by:

$$E_1(x) = \int_x^{\infty} \frac{e^{-y}}{y} dy, \quad 0 < x \ll 1: \quad E_1(x) \approx \ln(1/x) - \gamma, \quad \gamma = 0.5772. \quad (4.22)$$

Here, γ is Euler's constant. The logarithmic approximation is valid for small x . We get the following approximation for large times:

$$T_f(t) \approx \frac{q_{\text{inj}}}{4\pi\lambda} \cdot \left[\ln\left(\frac{4at}{r_p^2}\right) - \gamma \right] + q_{\text{inj}} \cdot R_p, \quad t \gg \frac{r_p^2}{4a}. \quad (4.23)$$

5 Inversion of Laplace transforms

A detailed derivation of the formulas for the Laplace inversion for the considered radial problems is presented Appendix 1. Here, a summary of the formulas is given.

5.1 General formula for radial problems

The Laplace transform $\bar{f}(s)$ of a function $f(t)$, which is defined for positive times t , is given by a well known integral:

$$f(t), \quad 0 \leq t < \infty: \quad \bar{f}(s) = \int_0^{\infty} e^{-st} \cdot f(t) dt, \quad s = u + i \cdot v. \quad (5.1)$$

Here, s is a complex number. The function $f(t)$ is obtained from the Laplace transform $\bar{f}(s)$ by a general inversion integral in the complex s -plane:

$$f(t) = \frac{1}{2\pi i} \cdot \int_{\Gamma_0} e^{st} \cdot \bar{f}(s) ds; \quad \Gamma_0 : s = u_0 + i \cdot v, \quad -\infty < v < \infty. \quad (5.2)$$

The real part $\text{Re}(s) = u_0$ is to be chosen so that all singularities and poles of $\bar{f}(s)$ lie to the left of Γ_0 . A better form for the integral is normally obtained by choosing another suitable integration path in the complex plane. This is discussed in Carslaw-Jaeger, 1959, for radial problems for a pipe (Ch. 13.5-8). This is also discussed in some detail in Appendix 1.

We have for our type of Laplace transforms the general formula (9.26) in Appendix 1:

$$f(t) = \frac{2}{\pi} \cdot \int_0^{\infty} \frac{1 - e^{-u^2 \cdot t/t_0}}{u} \cdot L(u) du. \quad (5.3)$$

Here, t_0 (in seconds) is an arbitrary time constant so that $t_0 \cdot s$ and the integration variable u in (5.3)-(5.5) become dimensionless. The function $L(u)$ is defined by (9.27):

$$L(u) = \text{Im}[-\bar{f}_t(u)], \quad \bar{f}_t(u) = s \cdot \bar{f}(s) \Big|_{\Gamma}. \quad (5.4)$$

$$\Gamma : t_0 \cdot s = -u^2 + i \cdot 0, \quad \sqrt{t_0 s} = i \cdot u, \quad 0 < u < \infty. \quad (5.5)$$

The first factor in the integral (5.3) depends on the dimensionless time t/t_0 , but it is independent of the particular Laplace transform $\bar{f}(s)$. The second factor, the function $L(u)$, is independent of t and represents the particular Laplace transform for the considered case.

The above formulas require that the following conditions are fulfilled:

1. $f(0) = 0$
2. $\frac{df}{dt} \rightarrow 0, \quad t \rightarrow \infty$
3. There are no poles or singularities except at $s = 0$

These is a cut in the complex s -plane to account for \sqrt{s} . See Figure A1.1 in Appendix 1 and (9.3).

We are also interested in the derivative with respect to time. We have directly by derivation of (5.3) or from (9.23):

$$\frac{df}{dt} = f_t(t) = \frac{2}{\pi} \cdot \int_0^{\infty} \frac{u}{t_0} \cdot e^{-u^2 \cdot t/t_0} \cdot L(u) du. \quad (5.6)$$

5.2 Inversion formulas for a pipe in ground

The Laplace transform of $T_f(t)$ is given by (4.16):

$$s \cdot \bar{T}_f(s) = \frac{q_{inj}}{C_p \cdot s + \frac{1}{R_p + \bar{R}_g(s)}}. \quad (5.7)$$

The *fluid temperature* is then, (5.3):

$$T_f(t) = \frac{2}{\pi} \cdot \int_0^{\infty} \frac{1 - e^{-u^2 t/t_p}}{u} \cdot L(u) du, \quad t_0 = t_p = \frac{r_p^2}{a}. \quad (5.8)$$

The time derivative is from (5.6):

$$\frac{dT_f}{dt} = \frac{2}{\pi} \cdot \int_0^{\infty} \frac{u}{t_0} \cdot e^{-u^2 t/t_0} \cdot L(u) du. \quad (5.9)$$

Here, we choose $t_0 = t_p$. The second factor $L(u)$ is, (5.4):

$$L(u) = \text{Im} \left[\frac{-q_{inj}}{C_p \cdot s + \frac{1}{R_p + \bar{R}_g(s)}} \right]_{\Gamma}, \quad \Gamma: t_p s = -u^2, \quad \sqrt{t_p s} = i \cdot u. \quad (5.10)$$

From (4.9) we have:

$$2\pi\lambda \cdot \bar{R}_g(s) \Big|_{\Gamma} = \frac{K_0(iu)}{iu \cdot K_1(iu)} = \frac{J_0(u) - i \cdot Y_0(u)}{u \cdot [J_1(u) - i \cdot Y_1(u)]}, \quad u > 0. \quad (5.11)$$

The temperature and the heat flux in the ground at the pipe become from (4.17) and (5.7):

$$\bar{T}_p(s) = \frac{\bar{R}_g(s)}{R_p + \bar{R}_g(s)} \cdot \bar{T}_f(s), \quad \bar{q}_p(s) = \frac{1}{R_p + \bar{R}_g(s)} \cdot \bar{T}_f(s). \quad (5.12)$$

The temperature in the ground at the radius r becomes from (4.18):

$$\bar{T}(r, s) = \bar{T}_p(s) \cdot \frac{K_0(\sigma_g \cdot r / r_p)}{K_0(\sigma_g)}, \quad \sigma_g = \sqrt{t_p s}, \quad 1 \leq r / r_p < \infty. \quad (5.13)$$

6 Pipe, borehole annulus and ground

We now consider the more complicated case shown in Figure 1.2. There is an annular borehole region between the pipe with the radius r_p and the outside ground in $r > r_b$. The thermal conductivity and thermal diffusivity in the borehole $r_p < r < r_b$ are denoted by λ_b and a_b , respectively. The corresponding quantities in the ground, $r > r_b$, are denoted by λ and a .

6.1 Mathematical problem for a pipe in a borehole in ground

The temperature shall satisfy the radial heat equation in the borehole and ground regions:

$$\frac{1}{a(r)} \cdot \frac{\partial T}{\partial t} = \frac{\partial^2 T}{\partial r^2} + \frac{1}{r} \cdot \frac{\partial T}{\partial r}, \quad a(r) = \begin{cases} a_b & r_p < r < r_b \\ a & r > r_b \end{cases}. \quad (6.1)$$

The radial heat flux (W/m) is

$$q(r, t) = 2\pi r [-\lambda(r)] \cdot \frac{\partial T}{\partial r}, \quad \lambda(r) = \begin{cases} \lambda_b & r_p < r < r_b \\ \lambda & r > r_b \end{cases}. \quad (6.2)$$

The heat balance for the fluid in the pipe water is as in (2.4):

$$q_{inj} = C_p \cdot \frac{dT_f}{dt} + q(r_p, t), \quad t > 0. \quad (6.3)$$

The boundary condition (2.3) at the pipe wall is:

$$T_f(t) - T(r_p, t) = R_p \cdot q(r_p, t). \quad (6.4)$$

The heat flux at the boundary between borehole and ground must be continuous:

$$\lambda_b \cdot \left. \frac{\partial T}{\partial r} \right|_{r=r_b-0} = \lambda \cdot \left. \frac{\partial T}{\partial r} \right|_{r=r_b+0}. \quad (6.5)$$

Finally, the initial temperatures are zero:

$$T_f(0) = 0; \quad T(r, 0) = 0, \quad r > r_p. \quad (6.6)$$

The above five equations define the considered thermal response problem. The primary input data are:

$$r_p, \quad r_b, \quad \lambda_b, \quad a_b = \frac{\lambda_b}{\rho_b c_b}, \quad \lambda, \quad a = \frac{\lambda}{\rho c}, \quad q_{inj}, \quad R_p, \quad C_p. \quad (6.7)$$

The solution to the above problem is given in Carslaw-Jaeger 1959, (Sections 13.5-6) for the case $C_p = 0$.

We will as in Sections 3 and 4 study the Laplace transforms of the above equations. The transforms of (6.3) and (6.4) become in accordance with (3.6) and (3.5):

$$\frac{q_{inj}}{s} = C_p \cdot s \cdot \bar{T}_f(s) + \bar{q}_p(s), \quad \bar{q}_p(s) = \bar{q}(r_p, s). \quad (6.8)$$

$$\bar{T}_f(s) - \bar{T}_p(s) = R_p \cdot \bar{q}_p(s), \quad \bar{T}_p(s) = \bar{T}(r_p, s). \quad (6.9)$$

The annular region is analyzed in Appendix 2. The results are summarized below.

6.2 Relations for an annular region

Relations between boundary fluxes and temperatures for an annular region are analyzed in Appendix 2. The following case is considered: The temperatures at the inner and outer radii may vary in any way with time. The initial temperature is zero. We are interested in the relations between the boundary heat fluxes and the boundary temperatures. Here, we change the indices 1 and 2 of Appendix 2 to p and b, respectively. We have:

$$\begin{aligned} r_1 &\rightarrow r_p, & \lambda &\rightarrow \lambda_b, & \bar{T}_1(s) &\rightarrow \bar{T}_p(s), & \bar{K}_1(s) &\rightarrow \bar{K}_p(s), & \bar{q}_1(s) &\rightarrow \bar{q}_p(s), \\ r_2 &\rightarrow r_b, & a &\rightarrow a_b, & \bar{T}_2(s) &\rightarrow \bar{T}_b(s), & \bar{K}_2(s) &\rightarrow \bar{K}_b(s), & \bar{q}_2(s) &\rightarrow \bar{q}_b(s). \end{aligned} \quad (6.10)$$

The relations between the Laplace transforms of the boundary temperatures, $\bar{T}_p(s)$ and $\bar{T}_b(s)$, and boundary heat fluxes, $\bar{q}_p(s)$ and $\bar{q}_b(s)$, become from (10.30):

$$\begin{cases} \bar{q}_p(s) = \bar{K}_p(s) \cdot (\bar{T}_p(s) - 0) + \bar{K}_t(s) \cdot (\bar{T}_p(s) - \bar{T}_b(s)), \\ -\bar{q}_b(s) = \bar{K}_b(s) \cdot (\bar{T}_b(s) - 0) + \bar{K}_t(s) \cdot (\bar{T}_b(s) - \bar{T}_p(s)). \end{cases} \quad (6.11)$$

Here, $-\bar{q}_b(s)$ is the heat flux *into* the annulus at the outer boundary.

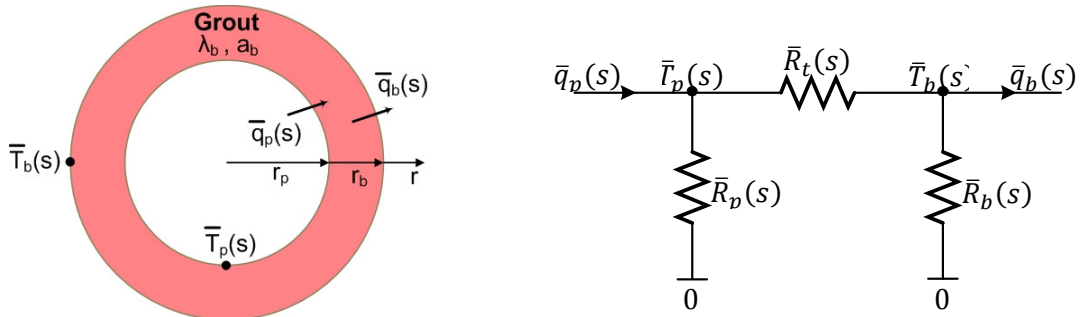

Figure 6.1 Thermal network (6.11) for the relations between the Laplace transforms of the boundary temperatures and radial heat fluxes for an annular region.

These relations between the Laplace transform of the boundary temperatures and heat fluxes may be regarded as a thermal network. Figure 6.1 shows the annular region and the

notations that are used (left), and the representation of the relations (6.11) as a thermal network for the borehole annulus (right).

The *transmittive* thermal resistance (and its inverse, the conductance) over the annular region is, (10.26)-(10.27):

$$\bar{R}_t(s) = \frac{1}{\bar{K}_t(s)} = \frac{D_0(\sigma_p, \sigma_b)}{2\pi\lambda_b}, \quad \sigma_p = r_p\sqrt{s/a_b}, \quad \sigma_b = r_b\sqrt{s/a_b}. \quad (6.12)$$

$$D_0(\sigma_p, \sigma_b) = K_0(\sigma_p)I_0(\sigma_b) - I_0(\sigma_p)K_0(\sigma_b) \quad (6.13)$$

The *absorptive* thermal resistances (and the inverse, the conductances) at the two sides $r = r_p$ and $r = r_b$ are, (10.28) and (10.29):

$$\bar{R}_p(s) = \frac{1}{\bar{K}_p(s)} = \frac{1}{2\pi\lambda_b} \cdot \frac{D_0(\sigma_p, \sigma_b)}{\sigma_p \cdot D(\sigma_p, \sigma_b) - 1}, \quad (6.14)$$

$$\bar{R}_b(s) = \frac{1}{\bar{K}_b(s)} = \frac{1}{2\pi\lambda_b} \cdot \frac{D_0(\sigma_p, \sigma_b)}{\sigma_b \cdot D(\sigma_b, \sigma_p) - 1}.$$

$$D(\sigma_p, \sigma_b) = I_1(\sigma_p)K_0(\sigma_b) + K_1(\sigma_p)I_0(\sigma_b). \quad (6.15)$$

6.3 The whole thermal network

Figure 6.2 shows the whole thermal network for the pipe with its heated fluid, the pipe wall, the borehole annulus and the infinite ground outside the borehole.

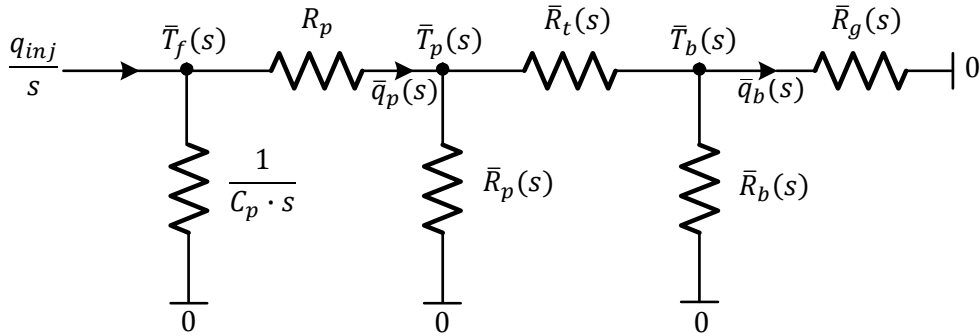

Figure 6.2 Thermal network for the Laplace transforms for pipe, borehole annulus and ground.

The network for the annular region, Figure 6.1, is inserted into the network for a pipe in ground, Figure 4.1, between the resistances R_p and $\bar{R}_g(s)$. The radius r_p is replaced by r_b , in the formula for $\bar{R}_g(s)$, (4.7):

$$\bar{R}_g(s) = \frac{1}{\bar{K}_g(s)} = \frac{1}{2\pi\lambda} \cdot \frac{K_0(\sigma_g)}{\sigma_g \cdot K_1(\sigma_g)}, \quad \sigma_g = r_b \sqrt{s/a}. \quad (6.16)$$

6.4 Pipe fluid temperature

The Laplace transform for the pipe water temperature is now readily obtained from the thermal network in Figure 6.2:

$$\bar{T}_f(s) = \frac{q_{inj}}{s} \cdot \frac{1}{C_p \cdot s + \frac{1}{R_p + \frac{1}{\bar{K}_p(s) + \frac{1}{\frac{1}{\bar{K}_t(s)} + \frac{1}{\bar{K}_b(s) + \bar{K}_g(s)}}}}}. \quad (6.17)$$

The network involves a sequence of composite resistances. We start from right in Figure 6.2. The conductances $\bar{K}_b(s)$ and $\bar{K}_g(s)$ lie in parallel and are added. The inverse of this composite conductance is added to the resistance $\bar{R}_t(s) = 1/\bar{K}_t(s)$. This composite resistance lies in parallel with $\bar{R}_p(s) = 1/\bar{K}_p(s)$ and their inverses are added. This composite resistance lie in series with the resistance of the pipe wall, R_p . The total composite resistance from R_p and rightwards lies in parallel with the thermal conductance $C_p \cdot s$.

The fluid temperature and its time derivative are from (5.3) and (5.9):

$$T_f(t) = \frac{2}{\pi} \cdot \int_0^{\infty} \frac{1 - e^{-u^2 t/t_0}}{u} \cdot L(u) du, \quad \frac{dT_f}{dt} = \frac{2}{\pi} \cdot \int_0^{\infty} \frac{u}{t_0} \cdot e^{-u^2 t/t_0} \cdot L(u) du. \quad (6.18)$$

Here, t_0 (in seconds) is an arbitrary time constant. The function $L(u)$ is defined by (5.4)-(5.5). The particular Laplace transform is given by (6.17). The Laplace transform of the fluid temperature is taken for s on the negative real axis Γ :

$$\Gamma: \quad t_0 \cdot s = -u^2, \quad \sqrt{t_0 s} = i \cdot u, \quad 0 < u < \infty. \quad (6.19)$$

We get with the notations (6.22)-(6.25) for the network components on the negative real axis Γ :

$$L(u) = \text{Im} \frac{-q_{inj}}{C_p \cdot \frac{-u^2}{t_0} + \frac{1}{R_p + \frac{1}{\bar{K}_p(u) + \frac{1}{\frac{1}{\bar{K}_t(u)} + \frac{1}{\bar{K}_b(u) + \bar{K}_g(u)}}}}}. \quad (6.20)$$

The four thermal resistances (and corresponding conductances) for the Laplace transforms, $\bar{R}_{\text{sub}}(s)$, (sub=t, p, b, g) are given by (6.12)-(6.16). On the negative real axis Γ , they become functions of the real variable u . We have from (6.12), (6.16) and (6.19):

$$\begin{aligned}\sigma_p &= iu\tau_p, & \sigma_b &= iu\tau_b, & \sigma_g &= iu\tau_g, \\ \tau_p &= \frac{r_p}{\sqrt{a_b t_0}}, & \tau_b &= \frac{r_b}{\sqrt{a_b t_0}}, & \tau_g &= \frac{r_b}{\sqrt{a t_0}}.\end{aligned}\quad (6.21)$$

The conductances become, retaining the same notation for $\bar{K}_{\text{sub}}(s)$ and $\bar{K}_{\text{sub}}(u)$, (sub=t, p, b, g):

$$\bar{K}_g(s)\Big|_{\Gamma} = 2\pi\lambda \cdot \frac{i u \tau_g \cdot K_1(i u \tau_g)}{K_0(i u \tau_g)} = \bar{K}_g(u), \quad (6.22)$$

$$\bar{K}_t(s)\Big|_{\Gamma} = \frac{2\pi\lambda_b}{D_0(iu\tau_p, iu\tau_b)} = \bar{K}_t(u), \quad (6.23)$$

$$\bar{K}_p(s)\Big|_{\Gamma} = 2\pi\lambda_b \cdot \frac{i u \tau_p \cdot D(iu\tau_p, iu\tau_b) - 1}{D_0(iu\tau_p, iu\tau_b)} = \bar{K}_p(u), \quad (6.24)$$

$$\bar{K}_b(s)\Big|_{\Gamma} = 2\pi\lambda_b \cdot \frac{i u \tau_b \cdot D(iu\tau_b, iu\tau_p) - 1}{D_0(iu\tau_p, iu\tau_b)} = \bar{K}_b(u). \quad (6.25)$$

Here, we use the functions (6.13) and (6.15):

$$D_0(\sigma_p, \sigma_b)\Big|_{\Gamma} = K_0(iu\tau_p)I_0(iu\tau_b) - I_0(iu\tau_p)K_0(iu\tau_b). \quad (6.26)$$

$$D(\sigma_p, \sigma_b)\Big|_{\Gamma} = I_1(iu\tau_p)K_0(iu\tau_b) + K_1(iu\tau_p)I_0(iu\tau_b). \quad (6.27)$$

The modified Bessel function are taken for imaginary arguments $iu\tau_{\text{sub}}$. The modified Bessel functions may then be expressed by ordinary Bessel functions. We have from (11.8) and (11.9) in Appendix 3:

$$D_0(\sigma_p, \sigma_b)\Big|_{\Gamma} = \frac{\pi}{2} \cdot [J_0(\tau_p u)Y_0(\tau_b u) - Y_0(\tau_p u)J_0(\tau_b u)]. \quad (6.28)$$

$$i \cdot D(\sigma_p, \sigma_b)\Big|_{\Gamma} = \frac{\pi}{2} \cdot [J_1(\tau_p u)Y_0(\tau_b u) - Y_1(\tau_p u)J_0(\tau_b u)]. \quad (6.29)$$

From (6.22)-(6.29), (11.7) and (6.16) we now have the final formulas for the thermal conductances and the corresponding resistances on the real negative axis:

$$\bar{K}_t(u) = \frac{1}{\bar{R}_t(u)} = \frac{4\lambda_b}{J_0(\tau_p u)Y_0(\tau_b u) - Y_0(\tau_p u)J_0(\tau_b u)}. \quad (6.30)$$

$$\bar{K}_p(u) = \frac{1}{\bar{R}_p(u)} = 4\lambda_b \cdot \frac{0.5\pi\tau_p u \cdot [J_1(\tau_p u)Y_0(\tau_b u) - Y_1(\tau_p u)J_0(\tau_b u)] - 1}{J_0(\tau_p u)Y_0(\tau_b u) - Y_0(\tau_p u)J_0(\tau_b u)} \quad (6.31)$$

$$\bar{K}_b(u) = \frac{1}{\bar{R}_b(u)} = 4\lambda_b \cdot \frac{0.5\pi\tau_b u \cdot [J_1(\tau_b u)Y_0(\tau_p u) - Y_1(\tau_b u)J_0(\tau_p u)] - 1}{J_0(\tau_p u)Y_0(\tau_b u) - Y_0(\tau_p u)J_0(\tau_b u)} \quad (6.32)$$

$$\bar{K}_g(u) = \frac{1}{\bar{R}_g(u)} = 2\pi\lambda \cdot \frac{\tau_g u \cdot [J_1(\tau_g u) - i \cdot Y_1(\tau_g u)]}{J_0(\tau_g u) - i \cdot Y_0(\tau_g u)}. \quad (6.33)$$

6.5 Laplace transforms for the other quantities

The other unknowns in the thermal network may be obtained by a sequence of heat balance equations. We have from Figure 6.2:

$$\frac{q_{inj}}{s} = C_p s \cdot [\bar{T}_f(s) - 0] + \bar{q}_p(s) \rightarrow \bar{q}_p(s). \quad (6.34)$$

$$\bar{T}_f(s) - \bar{T}_p(s) = R_p \cdot \bar{q}_p(s) \rightarrow \bar{T}_p(s). \quad (6.35)$$

$$\bar{q}_p(s) = \bar{K}_p(s) \cdot (\bar{T}_p(s) - 0) + \bar{K}_l(s) \cdot (\bar{T}_p(s) - \bar{T}_b(s)) \rightarrow \bar{T}_b(s). \quad (6.36)$$

$$-\bar{q}_b(s) = \bar{K}_b(s) \cdot (\bar{T}_b(s) - 0) + \bar{K}_l(s) \cdot (\bar{T}_b(s) - \bar{T}_p(s)) \rightarrow \bar{q}_b(s). \quad (6.37)$$

We also have the simpler relation:

$$\bar{q}_b(s) = \bar{K}_g(s) \cdot (\bar{T}_b(s) - 0). \quad (6.38)$$

The temperature in the ground outside the borehole is given by an expression of the type (4.3):

$$\bar{T}(r, s) = \frac{K_0(r\sqrt{s/a})}{K_0(r_b\sqrt{s/a})} \cdot \bar{T}_b(s) = \frac{K_0(\sigma_g \cdot r/r_b)}{K_0(\sigma_g)} \cdot \bar{T}_b(s), \quad r_b \leq r < \infty. \quad (6.39)$$

6.6 Approximations for short and long times

The approximations for short times in Section 4.4 may be used here. The water temperature in the pipe increases linearly for very short times, (4.19):

$$q(r_p, 0) = 0 \Rightarrow \frac{dT_f}{dt}(0) = \frac{q_{inj}}{C_p}; \quad T_f(t) \approx \frac{q_{inj}}{C_p} \cdot t. \quad (6.40)$$

The next approximation is to neglect the temperature increase outside the pipe wall. We get a as in (4.20) simple exponential solution:

$$T_f(t) \approx q_{\text{inj}} \cdot R_p \left(1 - e^{-t/(C_p \cdot R_p)}\right). \quad (6.41)$$

For large times, we may use again the well known line-source solution. The temperature solution for a constant heat injection at $r=0$ from time $t=0$ is given by the exponential integral:

$$T_{\text{ls}}(r, t) = \frac{q_{\text{inj}}}{4\pi\lambda} \cdot E_1\left(\frac{r^2}{4at}\right) \Rightarrow T_f(t) \approx T_{\text{ls}}(r_b, t) + q_{\text{inj}} \cdot R_{f \rightarrow b}. \quad (6.42)$$

In the approximation, we take the line-source solution at $r=r_b$. The (steady-state) temperature difference from pipe fluid to the borehole wall, i.e. q_{inj} times the thermal resistance from fluid to borehole wall, is added to give the right-hand expression. This resistance is equal to the resistance of the annular borehole or grout region, (8.11) (taking $\lambda_0 = 1$, $\lambda(r) = \lambda_b$, $r = r_b$), added to R_p . The logarithmic approximation(4.22), right, is valid for small x . We get the following approximation for large times:

$$T_f(t) \approx \frac{q_{\text{inj}}}{4\pi\lambda} \cdot \left[\ln\left(\frac{4at}{r_b^2}\right) - \gamma \right] + q_{\text{inj}} \cdot \left(R_p + \frac{1}{2\pi\lambda_b} \cdot \ln\left(\frac{r_b}{r_p}\right) \right), \quad t \gg \frac{r_b^2}{4a}. \quad (6.43)$$

7 Dimensionless form

We consider simpler case shown in Figure 1.2 with a pipe in ground.

7.1 Pipe in ground

The mathematical problem in Section 2 defined by (2.1)-(2.5) may be formulated in a *dimensionless* form. Eq. (2.1) may be written in an essentially dimensionless form:

$$\frac{r_p^2}{a} \cdot \frac{\partial T}{\partial t} = r_p^2 \cdot \left(\frac{\partial^2 T}{\partial r^2} + \frac{1}{r} \cdot \frac{\partial T}{\partial r} \right), \quad 1 \leq r/r_p < \infty. \quad (7.1)$$

The boundary condition at the pipe, (2.3), may be written:

$$T_f(t) = T(r_p, t) - 2\pi\lambda \cdot R_p \cdot r_p \cdot \left. \frac{\partial T}{\partial r} \right|_{r=r_p}. \quad (7.2)$$

The heat balance (2.4) for the fluid in the pipe may, after division by the factor $2\pi\lambda$ and the use of (2.3), left, for the heat flux at the pipe, be written:

$$\frac{q_{\text{inj}}}{2\pi\lambda} = \frac{C_p}{2\pi\lambda} \cdot \frac{dT_f}{dt} - r_p \cdot \left. \frac{\partial T}{\partial r} \right|_{r=r_p}, \quad \frac{C_p}{2\pi\lambda} = \frac{\pi r_p^2 \cdot \rho_f c_f}{2\pi \cdot \underbrace{a\rho c}_{\lambda}} = \frac{r_p^2}{a} \cdot \frac{\rho_f c_f}{2\rho c}. \quad (7.3)$$

From the three equations above we get a basic time scale, two dimensionless parameters, and a temperature factor:

$$t_p = \frac{r_p^2}{a}, \quad \mu = 2\pi\lambda \cdot R_p, \quad \sigma_f = \frac{\rho_f c_f}{2\rho c}, \quad T_{inj} = \frac{q_{inj}}{2\pi\lambda}. \quad (7.4)$$

The basic time $t_p = r_p^2 / a$ is a time scale associated with the pipe radius and the thermal diffusivity in the ground. The dimensionless quantity μ is a measure of the thermal resistance from pipe fluid to the ground at the pipe: $R_p = \mu / (2\pi\lambda)$ or $2\pi r_p \cdot R_p = r_p \cdot \mu / \lambda$. This means that a slab of ground with the thickness $\mu \cdot r_p$ has the same thermal resistance per unit area as that of the pipe ($2\pi r_p \cdot R_p$). The quantity σ_f is a measure of the volumetric heat capacity of the fluid compared to that of the ground (multiplied by two). Finally, the temperature T_{inj} (K or °C) is an overall temperature factor, which is proportional the heat injection rate q_{inj} .

Our problem is now defined by (7.1)-(7.3) and the initial condition (2.5). It involves the two dimensionless parameters μ and σ_f . The temperatures are proportional to T_{inj} , and they become functions of dimensionless time and radius:

$$T_f(t) = T_{inj} \cdot T'_f(t'), \quad T(r, t) = T_{inj} \cdot T'(r', t'), \quad t' = t / t_p, \quad r' = r / r_p. \quad (7.5)$$

Our problem in dimensionless form is now:

$$\frac{\partial T'}{\partial t'} = \frac{\partial^2 T'}{\partial r'^2} + \frac{1}{r'} \cdot \frac{\partial T'}{\partial r'}, \quad T'(r', 0) = 0, \quad 1 \leq r' < \infty. \quad (7.6)$$

$$T'_f(t') = T'(1, t') - \mu \cdot \left. \frac{\partial T'}{\partial r'} \right|_{r'=1}. \quad (7.7)$$

$$1 = \sigma_f \cdot \left. \frac{dT'_f}{dt'} - \frac{\partial T'}{\partial r'} \right|_{r'=1}, \quad t' > 0; \quad T'_f(0) = 0. \quad (7.8)$$

We note that the dimensionless heat flux becomes:

$$q(r, t) = -2\pi\lambda r \frac{\partial T}{\partial r} = -2\pi\lambda T_{inj} \cdot r' \frac{\partial T'}{\partial r'} = q_{inj} \cdot q'(r', t') \Rightarrow q'(r', t') = -r' \frac{\partial T'}{\partial r'}. \quad (7.9)$$

7.2 Laplace transform and thermal network

The Laplace transforms of the fluid temperature $T'_f(t')$ and the ground temperature $T'(r', t')$ are given by:

$$\bar{T}'_f(s') = \int_0^{\infty} e^{-s't'} \cdot T'_f(t') dt', \quad \bar{T}'(r', s') = \int_0^{\infty} e^{-s't'} \cdot T'(r', t') dt'. \quad (7.10)$$

The Laplace transform of (7.6) gives as in (4.3) the solution:

$$\bar{T}'(r', s') = \frac{K_0(r'\sqrt{s'})}{K_0(\sqrt{s'})} \cdot \bar{T}'(1, s'), \quad \bar{T}'(1, s') = \bar{T}'_p(s'), \quad 1 \leq r' < \infty. \quad (7.11)$$

The Laplace transform of the dimensionless heat flux at the pipe become:

$$\bar{q}'_p(s') = -\left. \frac{\partial \bar{T}'}{\partial r'} \right|_{r'=1} = \frac{\sqrt{s'} \cdot K_1(\sqrt{s'})}{K_0(\sqrt{s'})} \cdot \bar{T}'_p(s'). \quad (7.12)$$

We now have:

$$\bar{T}'_p(s') - 0 = \bar{R}'_g(s') \cdot \bar{q}'_p(s'); \quad \bar{R}'_g(s') = \frac{K_0(\sqrt{s'})}{\sqrt{s'} \cdot K_1(\sqrt{s'})}. \quad (7.13)$$

$$\bar{T}'_f(s') = \bar{T}'_p(s') + \mu \cdot \bar{q}'_p(s'). \quad (7.14)$$

$$\frac{1}{s'} = \sigma_f \cdot s' \cdot \bar{T}'_f(s') + \bar{q}'_p(s'). \quad (7.15)$$

Figure 7.1 shows the corresponding thermal network. It has the same structure as Figure 4.1. The heat capacity $C_p \cdot s$ is replaced by $\sigma_f \cdot s'$, the thermal resistance R_p by the dimensionless resistance μ and the resistance $\bar{R}_g(s)$ for the ground outside the pipe by the dimensionless $\bar{R}'_g(s')$.

From Figure 4.2 we have directly the Laplace transform for the dimensionless water temperature $T'_f(t)$:

$$\bar{T}'_f(s') = \frac{1}{s'} \cdot \frac{1}{\sigma_f \cdot s' + \frac{1}{\mu + \bar{R}'_g(s')}}}, \quad \bar{R}'_g(s') = \frac{K_0(\sqrt{s'})}{\sqrt{s'} \cdot K_1(\sqrt{s'})}. \quad (7.16)$$

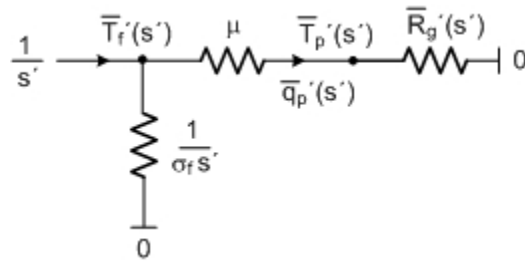

Figure 7.1 Thermal network for the Laplace transform for a pipe in the ground involving dimensionless parameters in accordance with the equations(7.13)-(7.15).

8 Numerical solution

We will in this section discuss direct numerical solution for the problem shown in Figure 1.1. The pipe lies in a borehole imbedded in an infinite ground. The step-response problem for a constant heating of the pipe fluid from time $t = 0$ is in particular studied. The simpler case with a pipe in ground, Figure 1.1, is presented in Section 8.8.

8.1 Radial heat equation

The general radial heat equation reads:

$$\rho(r)c(r) \cdot \frac{\partial T}{\partial t} = \frac{1}{r} \cdot \frac{\partial}{\partial r} \left[r \cdot \lambda(r) \cdot \frac{\partial T}{\partial r} \right], \quad r \geq r_p. \quad (8.1)$$

Here, the thermal properties ρ , c and λ may be constant, piecewise linear or any (positive) functions of r . This equation expresses a heat balance. In order to see this more clearly we rewrite the equation in the following way:

$$\rho c \cdot 2\pi r \cdot \frac{\partial T}{\partial t} = -\frac{\partial q}{\partial r}, \quad q(r,t) = -2\pi r \cdot \lambda \cdot \frac{\partial T}{\partial r}, \quad r \geq r_p. \quad (8.2)$$

The left-hand side is the rate of increase of heat content at the position r at time t . It is balanced by the radial derivative of the heat flux q (W/m). The radial heat flux intensity (W/m²) from Fourier's law is multiplied by the length of the circle at the radius r to get the total radial flux. The same factor occurs on the left-hand side of the heat balance equation.

The heat balance is discretized in the numerical solution. We consider a numerical cell in the form of an annulus, $r - 0.5\Delta r \leq r' \leq r + 0.5\Delta r$, as shown in Figure 8.1. Equation (8.2), left, is multiplied by $\Delta r \cdot \Delta t$:

$$\rho c \cdot 2\pi r \cdot \Delta r \cdot \frac{\partial T}{\partial t} \cdot \Delta t = -\frac{\partial q}{\partial r} \cdot \Delta r \cdot \Delta t. \quad (8.3)$$

Heat capacity in the annular cell (J/(mK)) is equal to the volumetric heat capacity times the area of the annular cell:

$$C_{\Delta r} = \rho c \cdot \pi \left[(r + 0.5\Delta r)^2 - (r - 0.5\Delta r)^2 \right] = \rho c \cdot 2\pi r \cdot \Delta r. \quad (8.4)$$

We use simple discrete approximations of the derivatives in (8.3):

$$\begin{aligned} \frac{\partial T}{\partial t} \cdot \Delta t &\approx T(r, t + \Delta t) - T(r, t), \\ -\frac{\partial q}{\partial r} \cdot \Delta r &\approx -[q(r + 0.5\Delta r, t) - q(r - 0.5\Delta r, t)]. \end{aligned} \quad (8.5)$$

A corresponding discrete approximations for the radial heat flux, (8.2), right is:

$$q(r + 0.5\Delta r, t) \approx -2\pi(r + 0.5\Delta r) \cdot \lambda(r + 0.5\Delta r) \cdot \frac{T(r + \Delta r, t) - T(r, t)}{\Delta r}. \quad (8.6)$$

Here, the value of the factor $r \cdot \lambda(r)$ is taken at the midpoint between r and $r + \Delta r$. A better approximation is to integrate over this interval. See Sections 8.2-3 below. By doing this we get a better approximation for the heat flux, and we will also obtain a numerically simpler form for the heat equation. See (8.16).

The heat balance for the considered cell is now from (8.3)-(8.5):

$$C_{\Delta r} \cdot [T(r, t + \Delta t) - T(r, t)] = [q(r - 0.5\Delta r, t) - q(r + 0.5\Delta r, t)] \cdot \Delta t. \quad (8.7)$$

The increase of the heat content in the cell is equal to the heat inflow through the left-hand boundary minus the right-hand outflow during the time step Δt .

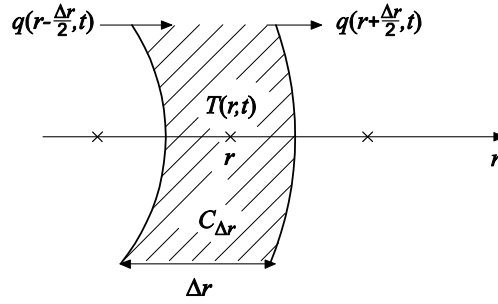

Figure 8.1 Annular cell with the heat balance (8.7).

8.2 Steady-state solution, radial thermal resistance

Let us first consider the radial steady-state solution. The radial heat flux is then constant:

$$T = T_s(r): \quad \frac{\partial T}{\partial t} = 0, \quad \frac{\partial q}{\partial r} = 0 \quad \Rightarrow \quad q(r, t) = q_s. \quad (8.8)$$

We have from (8.2), right:

$$q_s = -2\pi r \cdot \lambda(r) \cdot \frac{dT_s}{dr}, \quad -dT_s = \frac{q_s}{2\pi r \cdot \lambda(r)} dr \quad \Rightarrow \quad T_s(r_p) - T_s(r) = q_s \cdot R(r). \quad (8.9)$$

The temperature difference over the annular region from r_p to r is equal to the heat flux q_s (W/m) times the thermal resistance $R(r)$ (K/(W/m)) over the annulus. The thermal resistance is given by an integral, (8.9), center:

$$R(r) = \int_{r_p}^r \frac{1}{\lambda(r') \cdot 2\pi r'} dr', \quad \frac{dR}{dr} = \frac{1}{\lambda(r) \cdot 2\pi r}, \quad r_p \leq r < \infty. \quad (8.10)$$

8.3 Coordinate transformation using the radial thermal resistance

We now introduce essentially the radial thermal resistance, $R(r)$, as the new spatial coordinate $u = u(r)$:

$$u(r) = \lambda_0 \cdot R(r) = \int_{r_p}^r \frac{\lambda_0}{\lambda(r') \cdot 2\pi r'} dr', \quad u(r_p) = 0. \quad (8.11)$$

Here, λ_0 (W/(Km)) is a reference thermal conductivity, which may be chosen at will. The new coordinate u is then dimensionless. The radial heat flux is now:

$$\frac{du}{dr} = \frac{\lambda_0}{\lambda(r) \cdot 2\pi r} : \quad q(r,t) = -2\pi r \cdot \lambda(r) \cdot \frac{\partial T}{\partial r} = -\lambda_0 \cdot \frac{dr}{du} \cdot \frac{\partial T}{\partial r} = -\lambda_0 \cdot \frac{\partial T}{\partial u}. \quad (8.12)$$

So we have

$$q_u(u,t) = -\lambda_0 \cdot \frac{\partial T_u}{\partial u}, \quad u \geq 0. \quad (8.13)$$

Here, we denote the temperature as function of u by $T_u(u,t)$, and the radial heat flux by $q_u(u,t)$.

The heat balance (8.2) may now be transformed to a balance for $T_u(u,t)$. We use the inverse function, $r = r(u)$, to $u = u(r)$ and multiply by dr / du :

$$\rho c \cdot 2\pi r \cdot \frac{\partial T}{\partial t} \cdot \frac{dr}{du} = -\frac{\partial q}{\partial r} \cdot \frac{dr}{du} = -\frac{\partial q_u}{\partial u} = \lambda_0 \cdot \frac{\partial^2 T_u}{\partial u^2}, \quad u \geq 0. \quad (8.14)$$

The heat capacity (J/(K,m)) becomes:

$$C_u(u) = \rho c \cdot 2\pi r \cdot \frac{dr}{du} = \rho c \cdot \pi \frac{d}{du} \left[(r(u))^2 \right] = \frac{\lambda \rho c}{\lambda_0} \cdot [2\pi r(u)]^2. \quad (8.15)$$

Here, we use (8.12), left, in the last expression for the capacity. The heat equation with the new coordinate u is now:

$$C_u(u) \cdot \frac{\partial T_u}{\partial t} = -\frac{\partial q_u}{\partial u}, \quad q_u(u,t) = -\lambda_0 \cdot \frac{\partial T_u}{\partial u}, \quad u \geq 0. \quad (8.16)$$

This is the same equation as for one-dimensional heat conduction (linear heat conduction with the Cartesian coordinate x) with a *constant* thermal conductivity λ_0 . The interpolation problem in (8.6) is avoided. We use locally the exact steady-state relation.

8.4 Equations in discretized form

We use the following notations for cell n , Figure 8.2:

$$\begin{aligned}
u_{n-1}^+ &< u < u_n^+, & r_{n-1}^+ &< r < r_n^+, & n &= 1, 2, \dots, N; \\
u_n^+ &= n \cdot \Delta u, & r_n^+ &= r(n \cdot \Delta u), & n &= 0, 1, \dots, N; \\
T_{n,v} &= T_u(u_n, v \cdot \Delta t), & u_n &= (n - 0.5) \cdot \Delta u, & n &= 1, 2, \dots, N; \\
q_{n,v} &= q_u(u_n^+, v \cdot \Delta t), & n &= 0, 1, \dots, N.
\end{aligned} \tag{8.17}$$

We use a constant cell width Δu . The superscript + refers to the right-hand boundary of the numerical cell. The left-hand boundary of cell n is given by u_{n-1}^+ and r_{n-1}^+ , and the cell midpoint lies at $u = u_n$.

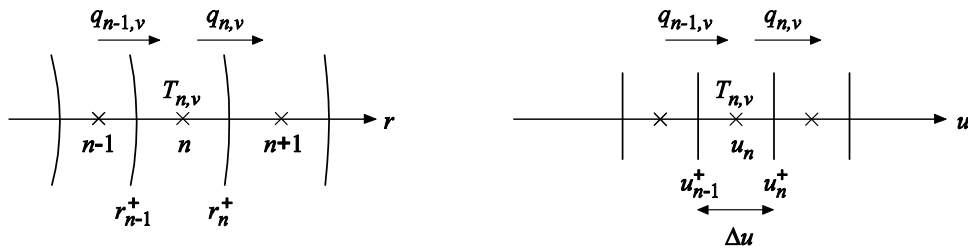

Figure 8.2. Numerical mesh (8.17) with the radial coordinate r and with the new coordinate u .

To get the heat balance for cell n , we integrate (8.16) in u :

$$\int_{(n-1) \cdot \Delta u}^{n \cdot \Delta u} C_u(u) \cdot \frac{\partial T_u}{\partial t} du = - \int_{(n-1) \cdot \Delta u}^{n \cdot \Delta u} \frac{\partial q_u}{\partial u} du = q_{n-1,v} - q_{n,v}. \tag{8.18}$$

We approximate the time derivative of the temperature in cell n by a direct finite difference:

$$\int_{(n-1) \cdot \Delta u}^{n \cdot \Delta u} C_u(u) \cdot \frac{\partial T_u}{\partial t} du \simeq \int_{(n-1) \cdot \Delta u}^{n \cdot \Delta u} C_u(u) du \cdot \frac{T_{n,v+1} - T_{n,v}}{\Delta t}. \tag{8.19}$$

The heat capacity of cell n (J/(mK)) is from (8.15), center:

$$C_n = \int_{(n-1) \cdot \Delta u}^{n \cdot \Delta u} C_u(u) du = \rho_n c_n \cdot \pi \left[(r_n^+)^2 - (r_{n-1}^+)^2 \right]. \tag{8.20}$$

Here, $\rho_n c_n$ denotes the volumetric heat capacity of cell n .

The heat balance equation is now:

$$C_n \cdot (T_{n,v+1} - T_{n,v}) \simeq (q_{n-1,v} - q_{n,v}) \cdot \Delta t. \tag{8.21}$$

The heat fluxes between cells are in general given by a conductance (W/(m,K)) times the temperature difference between the cells:

$$q_{n,v} \approx K_n \cdot (T_{n,v} - T_{n+1,v}), \quad n = 0, 1, \dots, N. \quad (8.22)$$

The thermal conductances over *internal* boundaries are all equal, (8.16), right:

$$K_n = \frac{\lambda_0}{\Delta u}, \quad n = 1, 2, \dots, N-1. \quad (8.23)$$

The boundary conductances K_0 and K_N depend on the particular boundary conditions of the considered problem.

We use explicit forward differences. There is a stability criterion which gives an upper limit for the time step Δt . If the limit is exceeded, the temperatures immediately start to oscillate and the solution “explodes”. To determine this limit, we note that the new temperature at time step $v+1$ is a linear combination of the temperature in the cell and the two adjacent cells, (8.21) and (8.22):

$$T_{n,v+1} = T_{n,v} + \frac{\Delta t}{C_n} \cdot [K_{n-1} \cdot (T_{n-1,v} - T_{n,v}) - K_n \cdot (T_{n,v} - T_{n+1,v})] \quad (8.24)$$

or

$$T_{n,v+1} = \frac{K_{n-1} \Delta t}{C_n} \cdot T_{n-1,v} + \left(1 - \frac{(K_{n-1} + K_n) \Delta t}{C_n}\right) \cdot T_{n,v} + \frac{K_n \Delta t}{C_n} \cdot T_{n+1,v}. \quad (8.25)$$

The sum of the three weight factors in (8.25) is of course 1. The iteration scheme is certainly stable if all weight factors are positive since the new temperature will lie between the three old ones. We have the general stability criterion:

$$\frac{(K_{n-1} + K_n) \Delta t}{C_n} \leq 1, \quad N = 1, \dots, N, \quad \text{or} \quad \Delta t \leq \min_{1 \leq n \leq N} \left(\frac{C_n}{K_{n-1} + K_n} \right). \quad (8.26)$$

8.5 Pipe in borehole in ground

For a pipe in a borehole in ground, we have two sets of thermal parameters:

$$\lambda(r) = \begin{cases} \lambda_b & \rho(r)c(r) = \begin{cases} \rho_b c_b & a(r) = \begin{cases} \lambda_b / (\rho_b c_b) & r_p \leq r < r_b \\ \lambda / (\rho c) & r > r_b \end{cases} \end{cases} \end{cases} \quad (8.27)$$

The coordinate relation $u(r)$ is, (8.11):

$$u(r) = \int_{r_p}^r \frac{\lambda_0}{\lambda(r') \cdot 2\pi r'} dr' = \begin{cases} \frac{\lambda_0}{2\pi \lambda_b} \cdot \ln\left(\frac{r}{r_p}\right) & r_p \leq r \leq r_b \\ u_b + \frac{\lambda_0}{2\pi \lambda} \cdot \ln\left(\frac{r}{r_b}\right) & r \geq r_b \end{cases} \quad (8.28)$$

The pipe boundary lies at $u = 0$ and the outer borehole boundary at u_b :

$$u(r_p) = 0, \quad u_b = u(r_b) = \frac{\lambda_0}{2\pi\lambda_b} \cdot \ln\left(\frac{r_b}{r_p}\right). \quad (8.29)$$

The inverse coordinate relation is obtained from (8.28):

$$r(u) = \begin{cases} r_p \cdot \exp(u \cdot 2\pi\lambda_b / \lambda_0) & 0 \leq u \leq u_b \\ r_b \cdot \exp((u - u_b) \cdot 2\pi\lambda / \lambda_0) & u \geq u_b \end{cases}. \quad (8.30)$$

The heat capacity $C_u(u)$ becomes, (8.15), right:

$$C_u(u) = \begin{cases} \frac{\lambda_b \rho_b c_b}{\lambda_0} \cdot 4\pi^2 r_p^2 \cdot \exp(u \cdot 4\pi\lambda_b / \lambda_0) & 0 \leq u < u_b \\ \frac{\lambda \rho c}{\lambda_0} \cdot 4\pi^2 r_b^2 \cdot \exp((u - u_b) \cdot 4\pi\lambda / \lambda_0) & u > u_b \end{cases}. \quad (8.31)$$

The heat capacity C_n of cell n becomes, (8.20), right:

$$C_n = \pi \left[(r_n^+)^2 - (r_{n-1}^+)^2 \right] \cdot \begin{cases} \rho_b c_b & 0 < u_n < u_b \\ \rho c & u_n > u_b \end{cases}, \quad u_n = (n - 0.5) \cdot \Delta u, \quad r_n^+ = r(u_n). \quad (8.32)$$

8.6 Equations for a pipe in borehole in ground

The heat equation using u as radial space coordinate is now, (8.16):

$$C_u(u) \cdot \frac{\partial T_u}{\partial t} = -\frac{\partial q_u}{\partial u}, \quad q_u = -\lambda_0 \cdot \frac{\partial T_u}{\partial u}, \quad 0 \leq u < \infty. \quad (8.33)$$

The boundary condition (2.3) at the pipe becomes:

$$u = 0: \quad q_u(0, t) = -\lambda_b \cdot \frac{\partial T_u}{\partial u} \Big|_{u=0} = K_p \cdot [T_f(t) - T_u(0, t)]. \quad (8.34)$$

The condition (6.5) at the boundary $r = r_b$ is automatically fulfilled when the coordinate u is used. The heat balance equation for step-response problem with heat injection to the pipe fluid is given by (2.4):

$$q_{inj} = C_p \cdot \frac{dT_f}{dt} + q_u(0, t), \quad t > 0. \quad (8.35)$$

The initial temperature in pipe fluid and ground is zero for the step-response problem:

$$T_f(0) = 0; \quad T_u(u, 0) = 0, \quad u > 0. \quad (8.36)$$

These equations (8.33)-(8.36) are reformulated in a discretized form as described in the above section. The notations of Figure 8.3 are used. We have to specify the boundary conditions. At the inner boundary there is the resistance R_p and the resistance $0.5\Delta u / \lambda_0$ from the outer pipe wall to the center of the first cell $u_1 = 0.5\Delta u$. The heat flux is zero at the outer boundary. So we have:

$$q_{0,v} = \frac{T_{0,v} - T_{1,v}}{R_p + 0.5\Delta u / \lambda_0}, \quad q_{N,v} = 0. \quad (8.37)$$

Using (8.23), we then have for the thermal conductances:

$$K_0 = \frac{1}{R_p + 0.5\Delta u / \lambda_0}, \quad K_n = \frac{\lambda_0}{\Delta u}, \quad n = 1, \dots, N-1, \quad K_N = 0. \quad (8.38)$$

In the numerical mesh, we use N_b cells in the borehole annulus and N_g cells in the ground outside the borehole:

$$u_b = N_b \cdot \Delta u, \quad u_{\max} = (N_b + N_g) \cdot \Delta u, \quad N = N_b + N_g. \quad (8.39)$$

The fluid temperature is placed in cell $n = 0$: $T_f(v \cdot \Delta t) = T_{0,v}$. Equation (8.35) becomes:

$$q_{\text{inj}} \cdot \Delta t = C_p \cdot (T_{0,v+1} - T_{0,v}) + q_{0,v} \cdot \Delta t. \quad (8.40)$$

There is a stability criterion for cell $n = 0$ as for the other cells. We have in analogy with (8.24)-(8.26):

$$T_{0,v+1} = \frac{q_i \Delta t}{C_p} + \left(1 - \frac{K_0 \Delta t}{C_p}\right) \cdot T_{0,v} + \frac{K_0 \Delta t}{C_p} \cdot T_{1,v} \Rightarrow \frac{K_0 \Delta t}{C_p} \leq 1, \quad \Delta t \leq \frac{C_p}{K_0}. \quad (8.41)$$

From (8.26) and (8.41), we have the following upper limits on the choice of time step:

$$\Delta t \leq \min_{1 \leq n \leq N} \left(\frac{C_n}{K_{n-1} + K_n} \right), \quad \Delta t \leq \frac{C_p}{K_0}. \quad (8.42)$$

The number of cells N_b in the annular borehole region is an input. The number of cells in the ground outside the borehole, N_g is chosen so the heat flux at outer boundary in the ground is zero, or negligible for the temperature development in the pipe fluid during considered time. Let t_{\max} denote the time up to which the fluid response temperature $T_f(t)$ is to be calculated.

The heat flux in the ground outside the heated pipe may be estimated with sufficient accuracy for our purpose from the solution for a continuous line source with the heat input q_{inj} (W/m) at $r = 0$ in the ground with the thermal diffusivity a and thermal conductivity λ . The solution is from Carslaw-Jaeger, pp.261-262 or from (4.21), left, and (4.22), left:

$$T_{\text{ls}}(r, t) = \frac{q_i}{4\pi\lambda} \cdot \int_{r^2/(4at)}^{\infty} \frac{e^{-y}}{y} dy, \quad q_{\text{ls}}(r, t) = q_{\text{inj}} \cdot \exp\left(-\frac{r^2}{4at}\right). \quad (8.43)$$

The heat flux $q_{\text{ls}}(r, t)$ is readily obtained from (8.2), right, by derivation with respect to r . We choose r_{max} so that the heat flux at that outer boundary is smaller than, say, $0.02 \cdot q_{\text{inj}}$:

$$q_{\text{inj}} \cdot \exp\left(-\frac{r_{\text{max}}^2}{4at_{\text{max}}}\right) \leq \underbrace{e^{-4}}_{=0.018} \cdot q_{\text{inj}} \quad \text{or} \quad r_{\text{max}} \geq \sqrt{4 \cdot 4at_{\text{max}}}. \quad (8.44)$$

The corresponding u_{max} is obtained from (8.30). So we have:

$$\begin{aligned} r_b \cdot \exp\left((u_{\text{max}} - u_b) \cdot 2\pi\lambda / \lambda_0\right) &\geq \sqrt{4 \cdot 4at_{\text{max}}} \Rightarrow \\ u_{\text{max}} - u_b = N_g \cdot \Delta u &\geq \frac{\lambda_0}{2\pi\lambda} \cdot \ln\left(\frac{4\sqrt{4at_{\text{max}}}}{r_b}\right). \end{aligned} \quad (8.45)$$

We choose N_g as the smallest integer that fulfills in above inequality:

$$N_g = 1 + \text{int}\left[\frac{\lambda_0}{\Delta u \cdot 2\pi\lambda} \cdot \ln\left(\frac{4\sqrt{4at_{\text{max}}}}{r_b}\right)\right]. \quad (8.46)$$

8.7 Summary of formulas for a pipe in borehole in ground

The following notations for cell n are used in accordance with Figures 8.2-3 and (8.17):

$$\begin{aligned} T_{0,v} &= T_f(v \cdot \Delta t), & T_{n,v} &= T_u((n-0.5) \cdot \Delta u, v \cdot \Delta t), & n &= 1, 2, \dots, N, \\ q_{n,v} &= q_u(n \cdot \Delta u, v \cdot \Delta t), & n &= 0, 1, \dots, N. \end{aligned} \quad (8.47)$$

The heat fluxes are given by (8.22):

$$q_{n,v} \simeq K_n \cdot \frac{T_{n,v} - T_{n+1,v}}{\Delta u}, \quad n = 0, 1, \dots, N. \quad (8.48)$$

The temperatures at the new time step, $t = (v+1) \cdot \Delta t$, are given by (8.21) and (8.40):

$$T_{n,v+1} = T_{n,v} + \frac{q_{n-1,v} - q_{n,v}}{C_n} \cdot \Delta t, \quad n = 1, 2, \dots, N. \quad (8.49)$$

$$T_{0,v+1} = T_{0,v} + \frac{q_{\text{inj}} - q_{0,v}}{C_p} \cdot \Delta t. \quad (8.50)$$

The initial temperature for $v=0$ are zero, (8.36):

$$T_{n,0} = 0, \quad n = 0, 1, \dots, N. \quad (8.51)$$

The above equations (8.48)-(8.51) give the numerical iterative calculation procedure. The conductances K_n , the heat capacities C_n and the time step Δt must be specified.

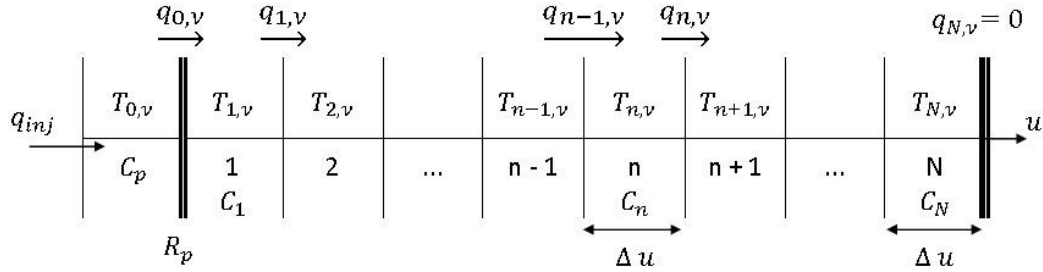

Figure 8.3. Notations for the numerical solution in Section 8.7

The input data are:

$$r_p, r_b, \lambda_b, \rho_b c_b, \lambda, \rho c, R_p, C_p, q_{inj}, N_b, t_{max}. \quad (8.52)$$

We choose $\lambda_0 = 2\pi\lambda_b$. Auxiliary data are from (8.29), (8.39) and (8.46):

$$\lambda_0 = 2\pi\lambda_b : \quad u_b = \ln\left(\frac{r_b}{r_p}\right), \quad \Delta u = \frac{u_b}{N_b}. \quad (8.53)$$

$$N_g = 1 + \text{int}\left[\frac{\lambda_b}{\Delta u \cdot \lambda} \cdot \ln\left(\frac{4\sqrt{at_{max}}}{r_b}\right)\right], \quad a = \frac{\lambda}{\rho c}, \quad N = N_b + N_g. \quad (8.54)$$

The new coordinate u is given by (8.28):

$$u(r) = \int_{r_p}^r \frac{2\pi\lambda_b}{\lambda(r') \cdot 2\pi r'} dr' = \begin{cases} \ln\left(\frac{r}{r_p}\right) & r_p \leq r \leq r_b \\ u_b + \frac{\lambda_b}{\lambda} \cdot \ln\left(\frac{r}{r_b}\right) & r \geq r_b \end{cases}. \quad (8.55)$$

The thermal conductances are given by (8.38):

$$K_0 = \frac{1}{R_p + 0.5\Delta u / (2\pi\lambda_b)}, \quad K_n = \frac{2\pi\lambda_b}{\Delta u}, \quad n = 1, \dots, N-1, \quad K_N = 0. \quad (8.56)$$

The radius as function of u is from (8.30):

$$r(u) = \begin{cases} r_p \cdot \exp(u) & 0 \leq u \leq u_b \\ r_b \cdot \exp((u - u_b) \cdot \lambda / \lambda_b) & u \geq u_b \end{cases}. \quad (8.57)$$

The right-hand boundary of cell n is, (8.32):

$$r_n^+ = r(n \cdot \Delta u), \quad n = 0, 1, \dots, N. \quad (8.58)$$

The heat capacity of cell n is from (8.32):

$$C_n = \pi \left[(r_n^+)^2 - (r_{n-1}^+)^2 \right] \cdot \begin{cases} \rho_b c_b & n = 1, \dots, N_b \\ \rho c & n = N_b + 1, \dots, N \end{cases}. \quad (8.59)$$

Finally, the time step must satisfy the inequalities (8.42):

$$\Delta t \leq \min_{1 \leq n \leq N} \left(\frac{C_n}{K_{n-1} + K_n} \right), \quad \Delta t \leq \frac{C_p}{K_0}. \quad (8.60)$$

We normally choose an even value (for example 120 seconds if the limit is 134).

8.8 Formulas for pipe in ground

The above formulas are modified somewhat in the simpler case with a pipe in ground, Figure 1.2. The iterative calculation procedure (8.47)-(8.51) is unchanged. The formulas for the conductances K_n , (8.56), and the time step Δt , (8.60), remain valid. The input data are:

$$r_p, \quad \lambda, \quad \rho c, \quad R_p, \quad C_p, \quad q_{inj}, \quad N, \quad t_{max}. \quad (8.61)$$

We choose $\lambda_0 = 2\pi\lambda$. Auxiliary data are:

$$\lambda_0 = 2\pi\lambda, \quad u_{max} = \ln \left(\frac{4\sqrt{at_{max}}}{r_p} \right), \quad \Delta u = \frac{u_{max}}{N}. \quad (8.62)$$

The new coordinate u , and the radius as function of u become:

$$u(r) = \int_{r_p}^r \frac{2\pi\lambda}{\lambda \cdot 2\pi r'} dr' = \ln \left(\frac{r}{r_p} \right), \quad r \geq r_p; \quad r(u) = r_p \cdot \exp(u), \quad u \geq 0. \quad (8.63)$$

The heat capacity of cell n is:

$$C_n = \pi \left[(r_n^+)^2 - (r_{n-1}^+)^2 \right] \cdot \rho c, \quad r_n^+ = r(n \cdot \Delta u), \quad n = 1, \dots, N; \quad r_0^+ = r_p. \quad (8.64)$$

References

Abramowitz, Stegun. 1964. Handbook of Mathematical Functions. NBS (National Bureau of Standards), Washington DC.

Carslaw, Jaeger. 1959. Conduction of Heat in Solids. Oxford Univ. Pr.

Hellström G. 1991. Ground Heat Storage. Thermal Analyses of Duct Storage Systems. Dep. of Mathematical Physics, University of Lund, Sweden. (Thesis)

Javed S., Claesson J. 2011. New Analytical and Numerical Solutions for the Short-term Analysis of Vertical Ground Heat Exchangers. ASHRAE 2011 Winter Conference, Las Vegas, USA. Jan. 29- Feb. 2, 2011.

Nehari Z. 1964. Introduction to Complex Analysis. Allen and Bacon Inc. Collage Mathematical Series, Boston.

Rohsenow W.M., Hartnett J.P., Ganic E.N. 1985. Handbook of Heat Transfer Fundamentals. Second ed. McGraw-Hill, New York.

Spiegel M. R. 1959. Laplace Transforms. Schaum Publishing Company, New York.

Appendix 1. Formulas for inversion of the Laplace transform

The discussion in this appendix involves complex-valued functions and in particular analytic functions, i.e. functions with a complex-valued derivative. Techniques from the theory of analytic functions and Laplace transforms are used. This is presented in a condensed form in Carslaw-Jaeger, 1959. General textbooks are, for example, Nehari, Complex Analysis, and Spiegel, Laplace Transforms. The presentation below presupposes a fair knowledge of these mathematical techniques. The results from Carslaw-Jaeger are given in greater detail with an emphasis on the particular complications for radial problems compared to one-dimensional linear problems (with a Cartesian x -coordinate).

A1.1 Inversion formula

The Laplace transform $\bar{f}(s)$ of a function $f(t)$, which is defined for positive times t , is given by the well known integral:

$$f(t), \quad 0 \leq t < \infty: \quad \bar{f}(s) = \int_0^{\infty} e^{-st} \cdot f(t) dt, \quad s = u + i \cdot v. \quad (9.1)$$

Here, s is a complex number with the real part u and the imaginary part v . The function $f(t)$ is obtained from the Laplace transform by a general inversion integral in the complex s -plane:

$$f(t) = \frac{1}{2\pi i} \cdot \int_{\Gamma_0} e^{st} \cdot \bar{f}(s) ds; \quad \Gamma_0: \quad s = u_0 + i \cdot v, \quad -\infty < v < \infty. \quad (9.2)$$

The path of integration in the complex plane, Γ_0 , is an infinite vertical line as shown in Figure A1.1. The real part $\text{Re}(s) = u_0$ is to be chosen so that all singularities and poles of $\bar{f}(s)$ lie to the left of Γ_0 .

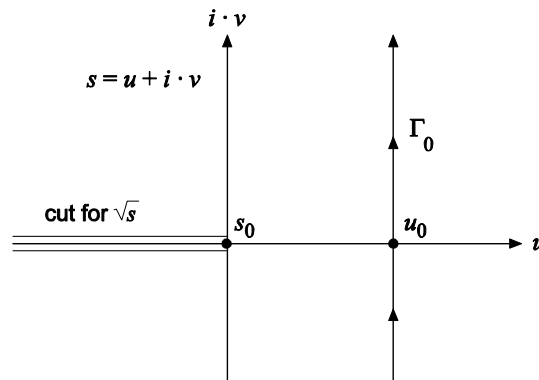

Figure A1.1 The complex s -plane with the path of integration Γ_0 in the inversion integral (9.2). There is a singularity at $s = 0$, and a cut along the negative real axis for the root \sqrt{s} .

Our Laplace transforms have a pole or singularity at $s = 0$. See for example (4.16) and (6.17). All our solutions involve \sqrt{s} , which means that there is a cut along the negative real axis, $s = u$, $-\infty < u < 0$, as shown in Figure A1.1. The value of \sqrt{s} differs on the negative real axis depending on from which side the axis is approached:

$$-\infty < u < 0: \quad \sqrt{u+0} \cdot i = i \cdot \sqrt{|u|}, \quad \sqrt{u-0} \cdot i = -i \cdot \sqrt{|u|}. \quad (9.3)$$

The value when approaching from below is the complex conjugate of the value when approaching from above.

The integral (9.2) along Γ_0 may be difficult to evaluate numerically, since the exponential in the integrand oscillates:

$$e^{s \cdot t} = e^{(u_0 + i \cdot v) \cdot t} = e^{u_0 \cdot t} \cdot e^{i \cdot v \cdot t} = e^{u_0 \cdot t} \cdot [\cos(v \cdot t) + i \cdot \sin(v \cdot t)]. \quad (9.4)$$

The cosine and sine functions change sign each time v is increased by π / t . The oscillations increase strongly when t increases. A standard way to avoid these difficulties is to use another path of integration. This technique is described in the next section.

A1.2 A better integration path in the complex plane

A better form for the integral is normally obtained by choosing another suitable integration path in the complex plane. This is discussed in Carslaw-Jaeger, 1959, for radial problems around a pipe. The technique is based in the fact that the integral of an analytic function along *any closed curve* in the complex s -plane is zero, provided that there are no poles or singularities on and inside the closed curve.

Figure A1.2 shows of the type of closed curves in the s -plane that are used for these integrals in Carslaw-Jaeger. The first part of the closed curve is the integral (9.2) in v along Γ_0 , but limited to a large finite range: $\Gamma_0^R: -R \leq v \leq R$. There are two circular arcs (and the horizontal parts for $0 < u < u_0$) with the radius $|s| = R$: Γ_R^+ and Γ_R^- , a line along the negative real axis approached from above, Γ , a small circle Γ_ε with the radius $|s| = \varepsilon$ around $s = 0$ and, finally, a line along the negative real axis approached from below, Γ_- . The direction in which the integration is performed is shown in the figure:

$$\Gamma_0^R + \Gamma_R^+ - \Gamma - \Gamma_\varepsilon + \Gamma_- + \Gamma_R^- = \Gamma_{\text{closed}}. \quad (9.5)$$

Here, a minus sign denotes that the integration is performed in the opposite direction.

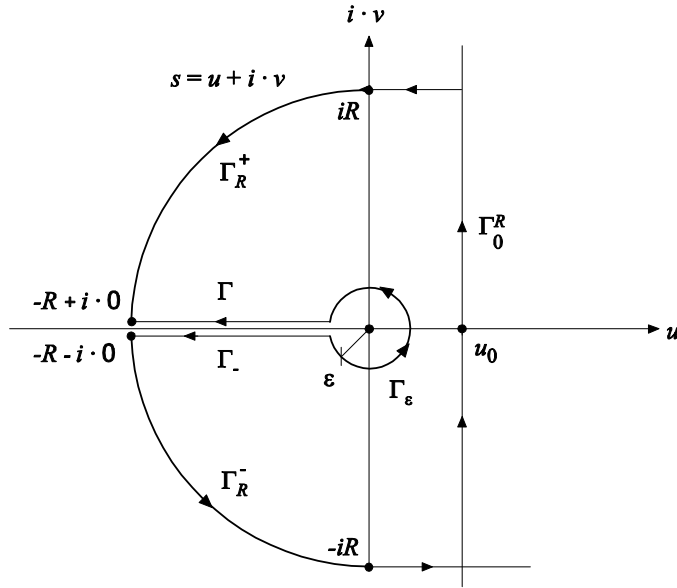

Figure A1.2 Considered closed path (9.5) for the inversion integral (9.2).

We will find that the considered Laplace transforms do not have any poles or singularities within the closed curve (9.5). This is showed for some of the cases considered in Carslaw-Jaeger or in references given there. It is always possible to calculate the values of $\bar{f}(s)$ numerically and convince oneself that the transform is regular in the enclosed region. The extension of (9.2) to the closed curve is then zero:

$$\frac{1}{2\pi i} \int_{\Gamma_{\text{closed}}} e^{s \cdot t} \cdot \bar{f}(s) ds = 0. \quad (9.6)$$

We will consider this integral in the limit $R \rightarrow \infty$ (and the limit $\varepsilon \rightarrow +0$). The integral over Γ_0^R tends to the integral (9.2) over the infinite vertical line Γ_0 . The integrals over the two circular arcs tend to zero, as is usual in this type of problems. We have:

$$R \rightarrow \infty: \int_{\Gamma_0^R} \dots ds \rightarrow \int_{\Gamma_0} \dots ds, \quad \int_{\Gamma_R^+} \dots ds \rightarrow 0, \quad \int_{\Gamma_R^-} \dots ds \rightarrow 0. \quad (9.7)$$

We now have from (9.2) and (9.5)-(9.7):

$$2\pi i \cdot f(t) = \int_{\Gamma_0} e^{s \cdot t} \cdot \bar{f}(s) ds = \int_{\Gamma} e^{s \cdot t} \cdot \bar{f}(s) ds + \int_{\Gamma_\varepsilon} e^{s \cdot t} \cdot \bar{f}(s) ds - \int_{\Gamma_-} e^{s \cdot t} \cdot \bar{f}(s) ds. \quad (9.8)$$

A1.3 Integration around $s=0$

We now consider the integral along the small circle Γ_ε . We have along this circle:

$$\Gamma_\varepsilon: \quad s = \varepsilon \cdot e^{i\phi}, \quad -\pi < \phi < \pi; \quad ds = \varepsilon \cdot i \cdot e^{i\phi} d\phi = i \cdot s d\phi \quad (9.9)$$

The integral is then:

$$\frac{1}{2\pi i} \cdot \int_{\Gamma_\varepsilon} e^{s \cdot t} \cdot \bar{f}(s) ds = \frac{1}{2\pi i} \cdot \int_{-\pi}^{\pi} e^{s \cdot t} \cdot \bar{f}(s) \cdot i \cdot s d\phi = \frac{1}{2\pi} \cdot \int_{-\pi}^{\pi} e^{s \cdot t} \cdot s \cdot \bar{f}(s) d\phi, \quad s = \varepsilon \cdot e^{i\phi}. \quad (9.10)$$

We consider the limit $\varepsilon \rightarrow +0$ and hence $s \rightarrow 0$. We need a general theorem for a limit for Laplace transforms:

$$s \cdot \bar{f}(s) = \int_0^\infty e^{-s \cdot t} \cdot f(t) \cdot s dt = [s \cdot t = t'] = \int_0^\infty e^{-t'} \cdot f\left(\frac{t'}{s}\right) dt' \Rightarrow$$

$$\lim_{s \rightarrow 0} [s \cdot \bar{f}(s)] = \int_0^\infty e^{-t'} \cdot f(\infty) dt' = f(\infty). \quad (9.11)$$

So we have in (9.10):

$$\frac{1}{2\pi i} \cdot \int_{\Gamma_\varepsilon} e^{s \cdot t} \cdot \bar{f}(s) ds \rightarrow \frac{1}{2\pi} \cdot \int_{-\pi}^{\pi} e^0 \cdot f(\infty) d\phi = f(\infty), \quad s, \varepsilon \rightarrow 0. \quad (9.12)$$

In our type of radial problems, we will find that the temperatures tend to infinity as $\ln(t)$ for large times t :

$$t \rightarrow \infty: \quad f(t) \sim A \cdot \ln(t) + B, \quad f(\infty) = \infty \quad (9.13)$$

This means that the integral (9.12) is *divergent* as the small radius ε tends to zero. The standard procedure for inversion of Laplace transforms cannot be used. But from (9.13) we have for the time derivative $f_t(t) = df / dt$:

$$t \rightarrow \infty: \quad f_t(t) = \frac{df}{dt} \sim \frac{A}{t}, \quad f_t(\infty) = 0. \quad (9.14)$$

This means that the standard inversion technique is applicable for $f_t(t) = df / dt$. This is done in the next section.

A1.4 Inversion integral for the time derivative

Following Carslaw-Jaeger, we consider the inversion for the time derivative:

$$f_t(t) = \frac{df}{dt}, \quad 0 \leq t < \infty: \quad \bar{f}_t(s) = \int_0^\infty e^{-s \cdot t} \cdot f_t(t) dt = s \cdot \bar{f}(s) \quad [f(0) = 0]. \quad (9.15)$$

The integral (9.10) applied for the time derivative becomes:

$$\frac{1}{2\pi i} \int_{\Gamma_\varepsilon} e^{s \cdot t} \cdot \bar{f}_t(s) ds = \frac{1}{2\pi i} \int_{-\pi}^{\pi} e^{s \cdot t} \cdot s \cdot \bar{f}(s) \cdot i \cdot s d\phi = \frac{1}{2\pi} \int_{-\pi}^{\pi} e^{s \cdot t} \cdot s \cdot s \cdot \bar{f}(s) d\phi. \quad (9.16)$$

In the limit $s \rightarrow 0$ we get:

$$\frac{1}{2\pi i} \int_{\Gamma_\varepsilon} e^{s \cdot t} \cdot \bar{f}_t(s) ds \rightarrow \frac{1}{2\pi} \int_{-\pi}^{\pi} 1 \cdot f_t(\infty) d\phi = 0, \quad s, \varepsilon \rightarrow 0. \quad (9.17)$$

Here, we have used (9.11) for $\bar{f}_t(s)$ and the limit (9.14):

$$\lim_{s \rightarrow 0} [s \cdot \bar{f}_t(s)] = \lim_{s \rightarrow 0} [s \cdot s \cdot \bar{f}(s)] = f_t(\infty) = 0. \quad (9.18)$$

The contribution from the integral around $s = 0$ is zero.

We now have from (9.17) and (9.8) applied to $f_t(t)$:

$$2\pi i \cdot \frac{df}{dt} = \int_{\Gamma_0} e^{s \cdot t} \cdot \bar{f}_t(s) ds = \int_{\Gamma} e^{s \cdot t} \cdot \bar{f}_t(s) ds - \int_{\Gamma_-} e^{s \cdot t} \cdot \bar{f}_t(s) ds. \quad (9.19)$$

Only the two integrals along the negative real axis remain. For the integration along the negative real axis, we choose the substitution $s = -u^2 / t_0$. Then we have:

$$\left. \begin{array}{l} \Gamma: \quad t_0 \cdot s = -u^2 + i \cdot 0, \quad \sqrt{t_0 s} = i \cdot u \\ \Gamma_-: \quad t_0 \cdot s = -u^2 - i \cdot 0, \quad \sqrt{t_0 s} = -i \cdot u \end{array} \right\}, \quad 0 < u < \infty, \quad ds = \frac{-2u}{t_0} du. \quad (9.20)$$

Here, t_0 (in seconds) is an arbitrary time constant so that $t_0 \cdot s = -u^2$ and the integration variable u become dimensionless. The integral (9.19) becomes:

$$\frac{df}{dt} = \frac{1}{2\pi i} \int_0^\infty e^{-u^2 \cdot t / t_0} \cdot \left[\bar{f}_t(s) \Big|_{\Gamma} - \bar{f}_t(s) \Big|_{\Gamma_-} \right] \cdot \frac{-2u}{t_0} du \quad (9.21)$$

The values of \sqrt{s} and $\bar{f}_t(s)$ on Γ_- is the complex conjugate of the values on Γ , (9.3). The difference is equal to the imaginary part times $2i$:

$$\bar{f}_t(s) \Big|_{\Gamma} - \bar{f}_t(s) \Big|_{\Gamma_-} = \bar{f}_t(s) \Big|_{\Gamma} - \left[\bar{f}_t(s) \Big|_{\Gamma} \right]^{\text{conjugate}} = 2i \cdot \text{Im} \left[\bar{f}_t(s) \Big|_{\Gamma} \right]. \quad (9.22)$$

We have derived the following quite general formula:

$$\frac{df}{dt} = \frac{2}{\pi} \int_0^\infty e^{-u^2 \cdot t / t_0} \cdot \frac{u}{t_0} L(u) du. \quad (9.23)$$

The function $L(u)$ is given by

$$L(u) = \text{Im}[-\bar{f}_t(u)], \quad \bar{f}_t(u) = s \bar{f}(s) \Big|_{\Gamma}, \quad (9.24)$$

$$\Gamma: t_0 \cdot s = -u^2 + i \cdot 0, \quad \sqrt{t_0 s} = i \cdot u, \quad 0 < u < \infty.$$

The remaining task is to integrate (9.23) in time to obtain $f(t)$.

A1.5 Time integration to obtain $f(t)$

Equation (9.23) is integrated over $0 \leq t' \leq t$:

$$\int_0^t e^{-u^2 \cdot t'/t_0} \cdot \frac{u}{t_0} dt' = \left[\frac{-1}{u} \cdot e^{-u^2 \cdot t'/t_0} \right]_{t'=0}^{t'=t} = \frac{1 - e^{-u^2 \cdot t/t_0}}{u}, \quad \int_0^t \frac{df}{dt'} dt' = f(t). \quad (9.25)$$

In the right-hand integral we use that $f(0) = 0$.

We have now for our type of Laplace transforms the general formula:

$$f(t) = \frac{2}{\pi} \cdot \int_0^{\infty} \frac{1 - e^{-u^2 \cdot t/t_0}}{u} \cdot L(u) du. \quad (9.26)$$

Here, t_0 (in seconds) is an arbitrary time constant so that $t_0 \cdot s$ and the integration variable u become dimensionless. The function $L(u)$ is defined by (9.24):

$$L(u) = \text{Im}[-\bar{f}_t(u)], \quad \bar{f}_t(u) = s \bar{f}(s) \Big|_{\Gamma}, \quad (9.27)$$

$$\Gamma: t_0 \cdot s = -u^2 + i \cdot 0, \quad \sqrt{t_0 s} = i \cdot u, \quad 0 < u < \infty.$$

The first factor in the integral (9.26) depends on the dimensionless time t/t_0 , and it is independent of the Laplace transform $\bar{f}(s)$. The second factor, the function $L(u)$, is independent of t and represents the particular Laplace transform for the considered case.

The two above formulas require that there are no poles or singularities except at $s = 0$. There is a cut along the negative real axis due to the root \sqrt{s} . The considered function $f(t)$ shall satisfy the conditions

$$f(0) = 0; \quad \frac{df}{dt} \rightarrow 0, \quad t \rightarrow \infty. \quad (9.28)$$

Appendix 2. Formulas for an annular region

We consider radial heat conduction in an annular region $r_1 < r < r_2$ with the thermal diffusivity a and the thermal conductivity λ . The initial temperature is zero:

$$\frac{1}{a} \cdot \frac{\partial T}{\partial t} = \frac{\partial^2 T}{\partial r^2} + \frac{1}{r} \cdot \frac{\partial T}{\partial r}, \quad T(r, 0) = 0, \quad r_1 < r < r_2. \quad (10.1)$$

The temperatures at the boundaries, $T_1(t) = T(r_1, t)$ and $T_2(t) = T(r_2, t)$, vary in any way with time. The corresponding boundary heat fluxes are: $q_1(t) = q(r_1, t)$ and $q_2(t) = q(r_2, t)$. We are interested in the relation between the boundary heat fluxes and the boundary temperatures.

The corresponding relations for the *Laplace transforms* of boundary temperatures and heat fluxes have a special symmetric structure that can be represented by a *thermal resistance network*. We will derive these relations here.

The general formulas for the Laplace transform of the temperature and its time derivative are:

$$\bar{T}(r, s) = \int_0^{\infty} e^{-st} \cdot T(r, t) dt, \quad \frac{\partial \bar{T}}{\partial t} = s \cdot \bar{T}(r, s) - \underbrace{T(r, 0)}_{=0}. \quad (10.2)$$

Derivation in time is replaced by multiplication by s in the transform. The heat equation (10.1) for the Laplace transform of the temperature becomes:

$$\frac{\partial^2 \bar{T}}{\partial r^2} + \frac{1}{r} \cdot \frac{\partial \bar{T}}{\partial r} = \frac{s}{a} \cdot \bar{T}(r, s) = \left(\sqrt{s/a}\right)^2 \cdot \bar{T}(r, s). \quad (10.3)$$

This equation is to be solved for any value of the complex-valued parameter s . The parameter s occurs in right-hand factor s/a ($1/m^2$) only. We may as in (3.2) and (4.1) scale r with $\sqrt{s/a}$ in the two terms on the left-hand side:

$$\bar{T}(r, s) = g(z), \quad z = r\sqrt{s/a} \Rightarrow \frac{d^2 g}{dz^2} + \frac{1}{z} \cdot \frac{dg}{dz} - g(z) = 0. \quad (10.4)$$

We get an ordinary differential equation for the complex variable $z = r\sqrt{s/a}$. The solutions are modified Bessel functions of zero order: $g(z) = I_0(z)$, $K_0(z)$. Both solutions are regular in the annular region which does not contain zero and infinite radius. The general solution is now:

$$\bar{T}(r, s) = A(s) \cdot I_0(r\sqrt{s/a}) + B(s) \cdot K_0(r\sqrt{s/a}), \quad r_1 \leq r \leq r_2. \quad (10.5)$$

Here, $A(s)$ and $B(s)$ are free functions of s .

The radial heat flux (W/m) and its Laplace transform are:

$$q(r,t) = 2\pi r \cdot (-\lambda) \frac{\partial T}{\partial r}, \quad \bar{q}(r,s) = 2\pi r \cdot (-\lambda) \frac{\partial \bar{T}}{\partial r}. \quad (10.6)$$

Insertion of (10.5) gives:

$$\bar{q}(r,s) = 2\pi r \cdot (-\lambda) \left[A(s) \cdot I_0'(r\sqrt{s/a}) + B(s) \cdot K_0'(r\sqrt{s/a}) \right] \cdot \sqrt{s/a}. \quad (10.7)$$

With $I_0'(z) = I_1(z)$ and $K_0'(z) = -K_1(z)$, we get:

$$\bar{q}(r,s) = 2\pi\lambda \cdot r\sqrt{s/a} \left[-A(s) \cdot I_1(r\sqrt{s/a}) + B(s) \cdot K_1(r\sqrt{s/a}) \right]. \quad (10.8)$$

The Laplace transforms of the boundary temperatures and heat fluxes are:

$$\begin{cases} \bar{T}_1(s) = \bar{T}(r_1, s) \\ \bar{T}_2(s) = \bar{T}(r_2, s), \end{cases} \quad \begin{cases} \bar{q}_1(s) = \bar{q}(r_1, s) \\ \bar{q}_2(s) = \bar{q}(r_2, s). \end{cases} \quad (10.9)$$

From (10.5) and (10.8), we get:

$$\begin{aligned} \bar{T}_1(s) &= I_0(\sigma_1) \cdot A(s) + K_0(\sigma_1) \cdot B(s), & \sigma_1 &= r_1\sqrt{s/a}, \\ \bar{T}_2(s) &= I_0(\sigma_2) \cdot A(s) + K_0(\sigma_2) \cdot B(s), & \sigma_2 &= r_2\sqrt{s/a}. \end{aligned} \quad (10.10)$$

$$\begin{aligned} \bar{q}_1(s) &= 2\pi\lambda \cdot \sigma_1 \left[-I_1(\sigma_1) \cdot A(s) + K_1(\sigma_1) \cdot B(s) \right], \\ \bar{q}_2(s) &= 2\pi\lambda \cdot \sigma_2 \left[-I_1(\sigma_2) \cdot A(s) + K_1(\sigma_2) \cdot B(s) \right]. \end{aligned} \quad (10.11)$$

In matrix form we have:

$$\begin{pmatrix} \bar{T}_1 \\ \bar{T}_2 \end{pmatrix} = \begin{pmatrix} I_0(\sigma_1) & K_0(\sigma_1) \\ I_0(\sigma_2) & K_0(\sigma_2) \end{pmatrix} \cdot \begin{pmatrix} A \\ B \end{pmatrix}. \quad (10.12)$$

$$\begin{pmatrix} \bar{q}_1 \\ \bar{q}_2 \end{pmatrix} = 2\pi\lambda \cdot \begin{pmatrix} -\sigma_1 I_1(\sigma_1) & \sigma_1 K_1(\sigma_1) \\ -\sigma_2 I_1(\sigma_2) & \sigma_2 K_1(\sigma_2) \end{pmatrix} \cdot \begin{pmatrix} A \\ B \end{pmatrix}. \quad (10.13)$$

The inverse of (10.12) may be written:

$$\begin{pmatrix} A \\ B \end{pmatrix} = \frac{1}{D_0(\sigma_1, \sigma_2)} \cdot \begin{pmatrix} -K_0(\sigma_2) & K_0(\sigma_1) \\ I_0(\sigma_2) & -I_0(\sigma_1) \end{pmatrix} \cdot \begin{pmatrix} \bar{T}_1 \\ \bar{T}_2 \end{pmatrix}. \quad (10.14)$$

$$D_0(\sigma_1, \sigma_2) = K_0(\sigma_1)I_0(\sigma_2) - I_0(\sigma_1)K_0(\sigma_2). \quad (10.15)$$

Elimination of A and B gives a relation between the boundary fluxes and temperatures:

$$\begin{pmatrix} \bar{q}_1 \\ \bar{q}_2 \end{pmatrix} = \frac{2\pi\lambda}{D_0(\sigma_1, \sigma_2)} \cdot \underbrace{\begin{pmatrix} -\sigma_1 I_1(\sigma_1) & \sigma_1 K_1(\sigma_1) \\ -\sigma_2 I_1(\sigma_2) & \sigma_2 K_1(\sigma_2) \end{pmatrix} \cdot \begin{pmatrix} -K_0(\sigma_2) & K_0(\sigma_1) \\ I_0(\sigma_2) & -I_0(\sigma_1) \end{pmatrix}}_{\mathbf{M}} \cdot \begin{pmatrix} \bar{T}_1 \\ \bar{T}_2 \end{pmatrix} \quad (10.16)$$

Matrix multiplication gives:

$$\mathbf{M} = \begin{pmatrix} \sigma_1 \cdot [I_1(\sigma_1)K_0(\sigma_2) + K_1(\sigma_1)I_0(\sigma_2)] & -\sigma_1 \cdot [I_1(\sigma_1)K_0(\sigma_1) + K_1(\sigma_1)I_0(\sigma_1)] \\ \sigma_2 \cdot [I_1(\sigma_2)K_0(\sigma_2) + K_1(\sigma_2)I_0(\sigma_2)] & -\sigma_2 \cdot [I_1(\sigma_2)K_0(\sigma_1) + K_1(\sigma_2)I_0(\sigma_1)] \end{pmatrix}. \quad (10.17)$$

The diagonal terms become:

$$\mathbf{M}_{1,1} = \sigma_1 \cdot D(\sigma_1, \sigma_2), \quad \mathbf{M}_{2,2} = -\sigma_2 \cdot D(\sigma_2, \sigma_1). \quad (10.18)$$

Here, we use the function

$$D(\sigma_1, \sigma_2) = I_1(\sigma_1)K_0(\sigma_2) + K_1(\sigma_1)I_0(\sigma_2). \quad (10.19)$$

The non-diagonal terms are:

$$\begin{aligned} \mathbf{M}_{1,2} &= -\sigma_1 \cdot [I_1(\sigma_1)K_0(\sigma_1) + K_1(\sigma_1)I_0(\sigma_1)] = -1, \\ \mathbf{M}_{2,1} &= \sigma_2 \cdot [I_1(\sigma_2)K_0(\sigma_2) + K_1(\sigma_2)I_0(\sigma_2)] = 1. \end{aligned} \quad (10.20)$$

Here, the general Wronskian relation is used:

$$I_1(z)K_0(z) + K_1(z)I_0(z) = \frac{1}{z}. \quad (10.21)$$

We have from (10.16)-(10.20):

$$\begin{aligned} \bar{q}_1 &= \frac{2\pi\lambda}{D_0(\sigma_1, \sigma_2)} \cdot \{\sigma_1 \cdot D(\sigma_1, \sigma_2) \cdot \bar{T}_1 - 1 \cdot \bar{T}_2\}, \\ \bar{q}_2 &= \frac{2\pi\lambda}{D_0(\sigma_1, \sigma_2)} \cdot \{1 \cdot \bar{T}_1 - \sigma_2 \cdot D(\sigma_2, \sigma_1) \cdot \bar{T}_2\}. \end{aligned} \quad (10.22)$$

The heat influxes to the annulus are \bar{q}_1 and $-\bar{q}_2$. We get for the boundary influxes a symmetric cross term for the temperature difference $\bar{T}_1 - \bar{T}_2$ over the annulus:

$$\bar{q}_1 = \frac{2\pi\lambda}{D_0(\sigma_1, \sigma_2)} \cdot \{[\sigma_1 \cdot D(\sigma_1, \sigma_2) - 1] \cdot \bar{T}_1 + 1 \cdot (\bar{T}_1 - \bar{T}_2)\}. \quad (10.23)$$

$$-\bar{q}_2 = \frac{2\pi\lambda}{D_0(\sigma_1, \sigma_2)} \cdot \{[\sigma_2 \cdot D(\sigma_2, \sigma_1) - 1] \cdot \bar{T}_2 + 1 \cdot (\bar{T}_2 - \bar{T}_1)\}. \quad (10.24)$$

We have derived the following relations between the boundary temperatures and influxes:

$$\begin{cases} \bar{q}_1(s) = \bar{K}_1(s) \cdot \bar{T}_1(s) + \bar{K}_t(s) \cdot (\bar{T}_1(s) - \bar{T}_2(s)) \\ -\bar{q}_2(s) = \bar{K}_2(s) \cdot \bar{T}_2(s) + \bar{K}_t(s) \cdot (\bar{T}_2(s) - \bar{T}_1(s)) \end{cases} \quad (10.25)$$

The factors before the temperatures may be interpreted as thermal conductances. The factor before the temperature difference is the *transmittive thermal conductance*:

$$\bar{K}_t(s) = \frac{2\pi\lambda}{D_0(\sigma_1, \sigma_2)}, \quad \sigma_1 = r_1\sqrt{s/a}, \quad \sigma_2 = r_2\sqrt{s/a}. \quad (10.26)$$

$$D_0(\sigma_1, \sigma_2) = K_0(\sigma_1)I_0(\sigma_2) - I_0(\sigma_1)K_0(\sigma_2). \quad (10.27)$$

The two *absorptive thermal conductances* are the factors before the boundary temperatures:

$$\bar{K}_1(s) = 2\pi\lambda \cdot \frac{\sigma_1 \cdot D(\sigma_1, \sigma_2) - 1}{D_0(\sigma_1, \sigma_2)} = \bar{K}_t(s) \cdot [\sigma_1 \cdot D(\sigma_1, \sigma_2) - 1], \quad (10.28)$$

$$\bar{K}_2(s) = 2\pi\lambda \cdot \frac{\sigma_2 \cdot D(\sigma_2, \sigma_1) - 1}{D_0(\sigma_1, \sigma_2)} = \bar{K}_t(s) \cdot [\sigma_2 \cdot D(\sigma_2, \sigma_1) - 1].$$

$$D(\sigma_1, \sigma_2) = I_1(\sigma_1)K_0(\sigma_2) + K_1(\sigma_1)I_0(\sigma_2). \quad (10.29)$$

The corresponding thermal network for the relations between the Laplace transforms of the boundary temperatures and boundary heat fluxes is now:

$$\begin{aligned} \bar{q}_1(s) &= \bar{K}_1 \cdot (\bar{T}_1(s) - 0) + \bar{K}_t \cdot (\bar{T}_1(s) - \bar{T}_2(s)), \\ -\bar{q}_2(s) &= \bar{K}_2 \cdot (\bar{T}_2(s) - 0) + \bar{K}_t \cdot (\bar{T}_2(s) - \bar{T}_1(s)). \end{aligned} \quad (10.30)$$

These relations are, with the changes (6.10) of indices, shown in Figure 6.1. The heat flux at the left-hand boundary $r = r_1$ is the sum of the absorptive flux, $\bar{K}_1 \cdot (\bar{T}_1 - 0)$, and the transmittive flux, $\bar{K}_t \cdot (\bar{T}_1 - \bar{T}_2)$. In the absorptive fluxes, we use the boundary temperature minus zero as driving temperature difference. It should be noted that the transmittive flux is the same at the two boundaries except for the sign.

The inverse of the conductances are the corresponding thermal resistances:

$$\bar{R}_t = \frac{1}{\bar{K}_t(s)}, \quad \bar{R}_1(s) = \frac{1}{\bar{K}_1(s)}, \quad \bar{R}_2(s) = \frac{1}{\bar{K}_2(s)}. \quad (10.31)$$

The relations (10.30) using thermal resistances instead of conductances are:

$$\bar{q}_1(s) = \frac{\bar{T}_1(s) - 0}{\bar{R}_1(s)} + \frac{\bar{T}_1(s) - \bar{T}_2(s)}{\bar{R}_t(s)}, \quad -\bar{q}_2(s) = \frac{\bar{T}_2(s) - 0}{\bar{R}_2(s)} + \frac{\bar{T}_2(s) - \bar{T}_1(s)}{\bar{R}_t(s)}. \quad (10.32)$$

Appendix 3. Bessel functions

Bessel functions are used extensively in this study. Here we present some basics for these functions and a number of formulas that are used in the derivations above. Good presentations of Bessel functions are found in Abramowitz, Stegun 1964, and Carslaw, Jaeger 1959.

Bessel's differential equation reads

$$\frac{d^2 g}{dz^2} + \frac{1}{z} \cdot \frac{dg}{dz} + \left(1 - \frac{n^2}{z^2}\right) g(z) = 0. \quad (11.1)$$

Here, the variable z may be complex-valued. There are two independent solutions for any value of n . The first solution, Bessel's function of the first kind of order n , $J_n(z)$, is regular at $z=0$, while the second solution, Bessel's function of the second kind of order n , $Y_n(z)$, has a singularity at $z=0$.

Bessel's modified differential equation reads

$$\frac{d^2 g}{dz^2} + \frac{1}{z} \cdot \frac{dg}{dz} - \left(1 + \frac{n^2}{z^2}\right) g(z) = 0. \quad (11.2)$$

There are again two independent solutions. The first solution, Bessel's modified function of the first kind of order n , $I_n(z)$, is regular at $z=0$, while the second solution, Bessel's modified function of the second kind of order n , $K_n(z)$, has a singularity at $z=0$.

The modified Bessel functions satisfy the so-called Wronskian relation:

$$I_1(z)K_0(z) + K_1(z)I_0(z) = \frac{1}{z}. \quad (11.3)$$

The complex-valued derivatives of the modified Bessel functions of zero order are:

$$K'_0(z) = -K_1(z), \quad I'_0(z) = I_1(z). \quad (11.4)$$

We use values of modified Bessel functions for imaginary arguments:

$$K_0(iu) = -\frac{i \cdot \pi}{2} [J_0(u) - i \cdot Y_0(u)], \quad (11.5)$$

$$K_1(iu) = -\frac{\pi}{2} \cdot [J_1(u) - i \cdot Y_1(u)], \quad u > 0.$$

$$I_0(iu) = J_0(u), \quad I_1(iu) = i \cdot J_1(u). \quad (11.6)$$

So we have:

$$\frac{K_0(iu)}{iu \cdot K_1(iu)} = \frac{J_0(u) - i \cdot Y_0(u)}{u \cdot [J_1(u) - i \cdot Y_1(u)]}, \quad u > 0. \quad (11.7)$$

Eq (6.26) involves modified Bessel functions for imaginary arguments. Using (11.5)-(11.6), we get (6.28):

$$\begin{aligned}
& K_0(iu\tau_p)I_0(iu\tau_b) - I_0(iu\tau_p)K_0(iu\tau_b) = \\
& -\frac{i\cdot\pi}{2} [J_0(u\tau_p) - i\cdot Y_0(u\tau_p)] J_0(u\tau_b) + J_0(u\tau_p) \frac{i\cdot\pi}{2} [J_0(u\tau_b) - i\cdot Y_0(u\tau_b)] = \quad (11.8) \\
& \frac{\pi}{2} \cdot [J_0(\tau_p u) Y_0(\tau_b u) - Y_0(\tau_p u) J_0(\tau_b u)]
\end{aligned}$$

Eq. (6.27) also involves modified Bessel functions for imaginary arguments. Using (11.5)-(11.6), we get (6.29):

$$\begin{aligned}
& i\cdot I_1(iu\tau_p)K_0(iu\tau_b) + i\cdot K_1(iu\tau_p)I_0(iu\tau_b) = \\
& \frac{\pi}{2} \left\{ iJ_1(u\tau_p) [J_0(u\tau_b) - i\cdot Y_0(u\tau_b)] + [-i\cdot J_1(u\tau_p) - Y_1(u\tau_p)] J_0(u\tau_b) \right\} = \quad (11.9) \\
& \frac{\pi}{2} \cdot [J_1(\tau_p u) Y_0(\tau_b u) - Y_1(\tau_p u) J_0(\tau_b u)].
\end{aligned}$$

Appendix 4 Solutions and studies in Mathcad

All solutions presented in this report have been implemented in the mathematical computer program Mathcad. Seven calculation sheets are appended on pages 53 to 101. Here, the solutions are studied and compared in various ways.

A4.1 Laplace solution for $T_f(t)$ for a pipe in borehole in ground

The Laplace solution for the fluid temperature for a pipe in a borehole in ground is studied in the first Mathcad sheet on pages 53-60.

Page 53: Definition of input data for a basic case using (2.7) for R_p . Thermal conductances from (6.21) and (6.30)-(6.33).

Page 54: $L(u)$ from (6.20) and $T_f(t)$ from (6.18). Curves for $T_f(t)$ up to $t=1000$, 10 000 and 100 000 s.

Page 55: Approximation (6.40) and (6.41) for short times, $0 < t < 600$ s. Diagram for $T_f(t)$ with logarithmic time, $10 < t < 10\,000\,000$ s (=116 days). Approximation (6.43) for large times.

Page 56: The two factors in the inversion integral (5.3) for $T_f(t)$ are $I(u, t')$, shown for a few dimensionless times $t' = t/t_0$, and $L(u)$.

Page 57: Diagrams showing $L(u)$, $I(u, 3)$ and their product to illustrate the inversion integral (5.3) for $t=3$ hours. The sum S is a numerical Riemann sum for the inversion integral.

Page 58: The integral (5.6) for the time derivative of $T_f(t)$. Diagram for times up to $t=1000$, 10 000 and 100 000 s. Approximation for short times from the derivative of (6.41).

Page 59. Comparison for $0 < t < 60$ s. Comparison for long times using the derivative of (6.43).

Page 60. Comparison for long times using the derivative of (6.43). The time factor $I_t(u, t')$ in (5.6) for the time derivative of $T_f(t)$ for a few dimensionless times.

A4.2 Numerical solution for $T_f(t)$ for a pipe in borehole in ground

The numerical solution for the fluid temperature for a pipe in a borehole is studied in the second Mathcad sheet on pages 61-69.

Page 61: Definition of input data for the basic case. We divide the annular grout region into $N_b=5$ numerical cells, and the maximum time is $t_{\max}=100$ hours. The formulas in Section 8.7 are used. We use (8.53), (8.54), (8.57) and (8.58)-(8.59). We get 16 cells in the ground and a total of $1+5+16=22$ cells. The outer boundary (with zero heat flux) in u becomes 2.79 which corresponds to the radius $r=3.88$ m.

Page 62: We use (8.56) for thermal conductances, and (8.60) to get the smallest stability time step 21.86 s. We choose the value 20 s as time step.

Page 63: Basic iteration loop which calculates the heat fluxes and temperature profile at each time step. The output is the profile after the last time step. Calculation of cell coordinates in u and r for the plots.

Page 64: Calculated temperature profiles in u for times from 100 s to 1 hour.

Page 65 : Calculated temperature profiles in r for times from 200 s to 100 hours.

Page 66: Temperature profiles near the outer boundary after 1 to 100 hours. Iteration loop to for calculation of $T_f(t)$. Here, $T_f(t) = T_0$ is saved for each time step.

Page 67: Plots of fluid temperature for $0 < t < 100$ hours and for $0 < t < 4$ hours.

Page 68: Plots of weighting function, i.e. the time derivative of the fluid temperature, for $0 < t < 4$ hours and for $0 < t < 20$ hours.

Page 69: Plots of weighting function for $0 < t < 100$ hours.

A4.3 Comparison of Laplace and numerical solution

A comparison of the fluid temperature $T_f(t)$ from the analytical Laplace solution and the numerical solution is presented in the third Mathcad sheet on pages 70-81. The formulas from the two above Mathcad sheets are used.

Page 70: Input data from the basic case for the Laplace solution. Formulas for the conductances.

Page 71: The function $L(u)$ and the inversion integral. The fluid temperature is saved as a value each minute during the first 100 hours in the vector Tf_Lap.

Page 72: Input and other data and functions for the numerical solution as in A4.2. We start with the case $N_b=5$.

Page 73: Iteration routine for the numerical solution as in A4.2. The fluid temperature is saved as a value each minute during the first 100 hours in the vector Tf_num.

Page 74 : The (overlapping) plots of Tf-Lap and Tf_num for $0 < t < 100$ and for $0 < t < 5$ hours.

Page 75: Plot of the difference between Tf_num and Tf_Lap with a value for each minute up to 100 hours. The difference increases to a maximum of 0.003 K after 0.3 hour. Then the difference decreases to zero at $t=1.8$ hours. After that the difference falls to -0.002 K for $20 < t < 100$ hours. In summary we have:

$$|T_{f_Lap}(t) - T_{f_num}(t)| < 0.003; \quad \Delta t = 20 \text{ s}, \quad N_b = 5, \quad N = 5 + 16. \quad (12.1)$$

The agreement between numerical and analytical solution is remarkably good. The error should lie in the numerical solution. The proposed numerical calculation technique seems quite good since we get such small error using $1+5+16=22$ cells only.

Pages 76-78: The numerical solution is recalculated for $N_b=3$. In this case we get:

$$|T_{f_Lap}(t) - T_{f_num}(t)| < 0.0085; \quad \Delta t = 60 \text{ s}, \quad N_b = 3, \quad N = 5 + 13. \quad (12.2)$$

Pages 78-80: The numerical solution is recalculated for $N_b=10$. In this case we get:

$$|T_{f_Lap}(t) - T_{f_num}(t)| < 0.0006; \quad \Delta t = 4 \text{ s}, \quad N_b = 10, \quad N = 10 + 31. \quad (12.3)$$

Page 81: The difference for $N_b=3, 5$ and 10 shown together for comparison for $0 < t < 5$ and $0 < t < 100$ hours.

A4.4 Studies and comparisons in the Laplace domain

The fourth Mathcad sheet on pages 82-88 presents a few studies of the solution in the Laplace domain.

Page 82: The input data of the basic example are used. The conductances in our networks are given in the report for any complex s and in particular for s on the negative real axis. We will control that we get the same results from the two sets of formulas. The direct formulas for the annulus and ground conductances at the negative axis are given by (6.30)-(6.33).

Page 83: The corresponding formulas for any s are given by (6.12)-(6.16). Here, modified Bessel function for complex arguments are required. These are given by built-in functions in Mathcad.

Page 84: Comparison of the two sets of formulas. We see that the values coincide with an error below 10^{-12} . This means that the simpler formulas (6.30)-(6.33) are indeed correct.

Page 85: The key factor $L(u)$ in the inversion integral is compared to the corresponding function from the conductances as functions of s from (6.12)-(6.16). The two curves coincide. The last formula gives the Laplace transform of the time derivative of the fluid temperature. The inversion integral is based on integration over the closed curve shown in Figure A1.2. The derivations require that there are no singularities or poles inside the closed curve.

Page 86: The two diagrams show the amplitude and argument of the Laplace transform. We see the singularity at $s=0$. The diagram for the amplitude indicates that it is *finite* in the whole complex plane except at $s=0$, which point is avoided in the closed loop, Figure A1.2. This means that there are no singularities or poles where the amplitude would become infinite inside the closed loop.

Pages 87-88: An approximation valid for small s from Taylor expansions of the involved Bessel functions. We see that the error is small for points very close to $s=0$.

A4.5 Pipe in ground

The solution for the simpler case of a pipe in ground, Figure 1.2, is presented in Section 4, and in dimensionless form in Section 7.

Page 89: Input data. $L(u)$ from (5.10)-(5.11), and inversion integral from (5.8). Plot of $L(u)$.

Pages 90-93: Dimensionless solution using (7.4) and (7.16). Plots of $L'(u, \sigma_f, \mu)$ for a few σ_f and for a few μ . Plots of dimensionless fluid temperature for these variations in σ_f and μ . A change of dimensionless pipe wall resistance μ changes the level of the asymptote for large time as shown in the graph on page 93.

A4.6 Comparison of pipe and borehole solutions

The borehole solution, taken for $\lambda_b = \lambda$, $\rho_b c_b = \rho c$, and the corresponding pipe solution shall be the same. This is controlled in the sixth Mathcad sheet on pages 94-96.

Pages 94-95: Input and formulas for the borehole solution and the pipe solution.

Page 96: Curves for $L(u)$ from the borehole solution and the corresponding function for the pipe solution (with a change due to different reference times t_0 and t_p , respectively). The difference between the curves is of the magnitude 10^{-15} . The two curves overlap completely, and the fluid temperatures become identical.

A4.7 Bessel functions

Bessel functions and some formulas for them are used in the report. The functions are plotted and the formulas are controlled in the last Mathcad sheet on pages 97-101.

Pages 97-98: Plot of ordinary and modified Bessel function ($J_n(x)=J_n(n,x)$ etc. in Mathcad).

Page 99: Control that the Bessel functions satisfy Bessel's differential equations. Control of the Wronskian relation (11.3).

Page 100: Control of the derivatives (11.4) and the formulas (11.5)-(11.7) for modified Bessel functions of imaginary arguments.

Page 101: Control of the relation from (6.26) and (6.28), and the relation from (6.27) and (6.29).

A4.1 Laplace solution for $T_f(t)$ for a pipe in borehole in ground

Step-response for borehole with pipe, annular grout and surrounding ground. Constant heat injection rate to the pipe fluid. Basic example.

J.C. Jan. 2011

Input data:

$$q_{inj} := 10 \quad \lambda_b := 1.5 \quad \rho c_b := 1550 \cdot 2000 \quad \lambda := 3.0 \quad \rho c := 2500 \cdot 750$$

$$r_p := 0.02 \cdot \sqrt{2} \quad r_b := 0.055 \quad a_b := \frac{\lambda_b}{\rho c_b} \quad a := \frac{\lambda}{\rho c} \quad C_p := \pi \cdot r_p^2 \cdot 4.18 \cdot 10^6$$

$$d_{pw} := 0.0023 \quad \lambda_p := 0.42 \quad h_p := 725 \quad R_p := \frac{1}{2 \cdot \pi \cdot \lambda_p} \cdot \ln\left(\frac{r_p}{r_p - d_{pw}}\right) + \frac{1}{2 \cdot r_p \cdot h_p}$$

$$t_0 := 3600 \quad C_p = 1.05 \times 10^4 \quad R_p = 0.06 \quad a_b = 4.84 \times 10^{-7} \quad a = 1.6 \times 10^{-6}$$

Thermal resistances:

$$\tau_p := \frac{r_p}{\sqrt{a_b \cdot t_0}} \quad \tau_b := \frac{r_b}{\sqrt{a_b \cdot t_0}} \quad \tau_g := \frac{r_b}{\sqrt{a \cdot t_0}}$$

$$Kb_t(u) := \frac{4 \cdot \lambda_b}{J_0(\tau_p \cdot u) \cdot Y_0(\tau_b \cdot u) - Y_0(\tau_p \cdot u) \cdot J_0(\tau_b \cdot u)} \quad (b = \text{bar})$$

$$Kb_p(u) := 4 \cdot \lambda_b \cdot \frac{0.5 \pi \cdot \tau_p \cdot u \cdot (J_1(\tau_p \cdot u) \cdot Y_0(\tau_b \cdot u) - Y_1(\tau_p \cdot u) \cdot J_0(\tau_b \cdot u)) - 1}{J_0(\tau_p \cdot u) \cdot Y_0(\tau_b \cdot u) - Y_0(\tau_p \cdot u) \cdot J_0(\tau_b \cdot u)}$$

$$Kb_b(u) := 4 \cdot \lambda_b \cdot \frac{0.5 \pi \cdot \tau_b \cdot u \cdot (J_1(\tau_b \cdot u) \cdot Y_0(\tau_p \cdot u) - Y_1(\tau_b \cdot u) \cdot J_0(\tau_p \cdot u)) - 1}{J_0(\tau_p \cdot u) \cdot Y_0(\tau_b \cdot u) - Y_0(\tau_p \cdot u) \cdot J_0(\tau_b \cdot u)}$$

$$Kb_g(u) := 2 \cdot \pi \cdot \lambda \cdot \frac{\tau_g \cdot u \cdot (J_1(\tau_g \cdot u) - i \cdot Y_1(\tau_g \cdot u))}{J_0(\tau_g \cdot u) - i \cdot Y_0(\tau_g \cdot u)}$$

Laplace transform and inversion integral:

$$L(u) := \text{Im} \left(\frac{-q_{inj}}{C_p \cdot \frac{-u^2}{t_0} + R_p + \frac{1}{Kb_p(u) + \frac{1}{\frac{1}{Kb_t(u)} + \frac{1}{Kb_b(u) + Kb_g(u)}}}} \right)$$

$$T_f(t) := \frac{2}{\pi} \int_0^{\infty} \frac{1 - e^{-u^2 \cdot \frac{t}{t_0}}}{u} \cdot L(u) \, du \quad T_f(0) = 0 \quad T_f(60) = 0.05 \quad T_f(600) = 0.43$$

$$T_f(3600) = 1.27 \quad T_f(10 \cdot 3600) = 2.22 \quad T_f(100 \cdot 3600) = 2.87 \quad T_f(1000 \cdot 3600) = 3.49$$

Fluid temperatures during 1000, 10 000 and 100 000 seconds

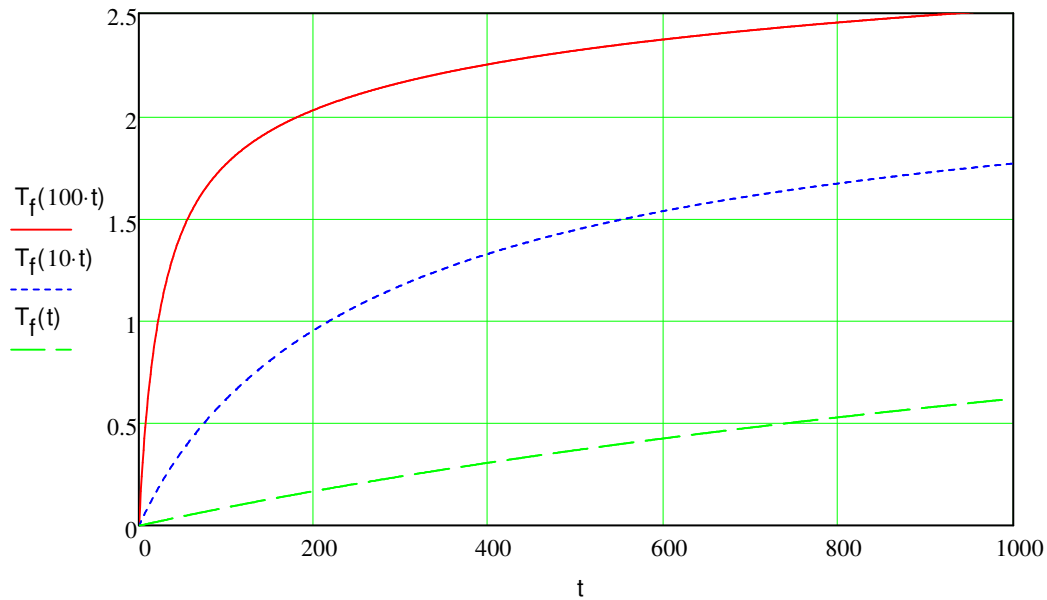

Time span in hours: $\frac{1000}{3600} = 0.28$ $\frac{10000}{3600} = 2.78$ $\frac{100000}{3600} = 27.78$

Approximation for very short times

$$T_{fs}(t) := q_{inj} \cdot R_p \cdot \left(1 - e^{-\frac{t}{C_p \cdot R_p}} \right) \quad q_{inj} \cdot R_p = 0.57 \quad C_p \cdot R_p = 593.8$$

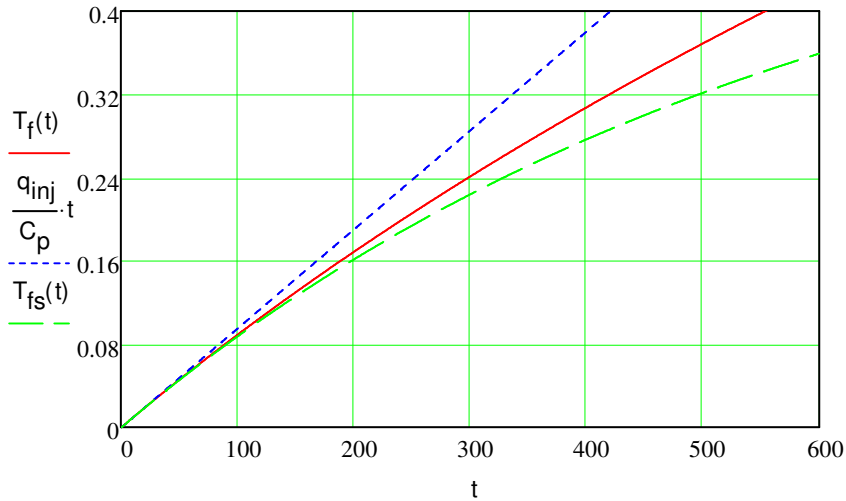

Logarithmic approximation for large times:

$$T_{fa}(t) := \frac{q_{inj}}{4 \cdot \pi \cdot \lambda} \cdot \left(\ln \left(\frac{4 \cdot a \cdot t}{r_b^2} \right) - 0.5772 \right) + q_{inj} \cdot \left(R_p + \frac{1}{2 \cdot \pi \cdot \lambda_b} \cdot \ln \left(\frac{r_b}{r_p} \right) \right) \quad \frac{10^5}{24 \cdot 3600} = 1.16$$

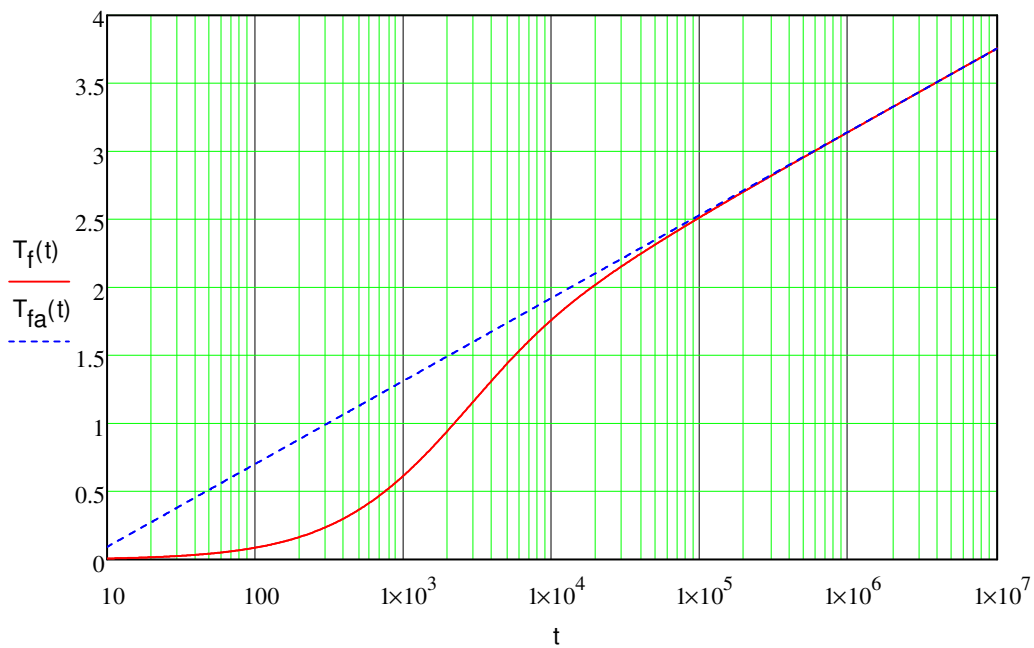

Integrand factors in inversion formula for the fluid temperature: $I(u, t')$ and $L(u)$.

$$I(u, t') := \frac{2}{\pi} \cdot \frac{1 - e^{-u^2 \cdot t'}}{u} \quad (t' \text{ time in hours, } t_0=3600)$$

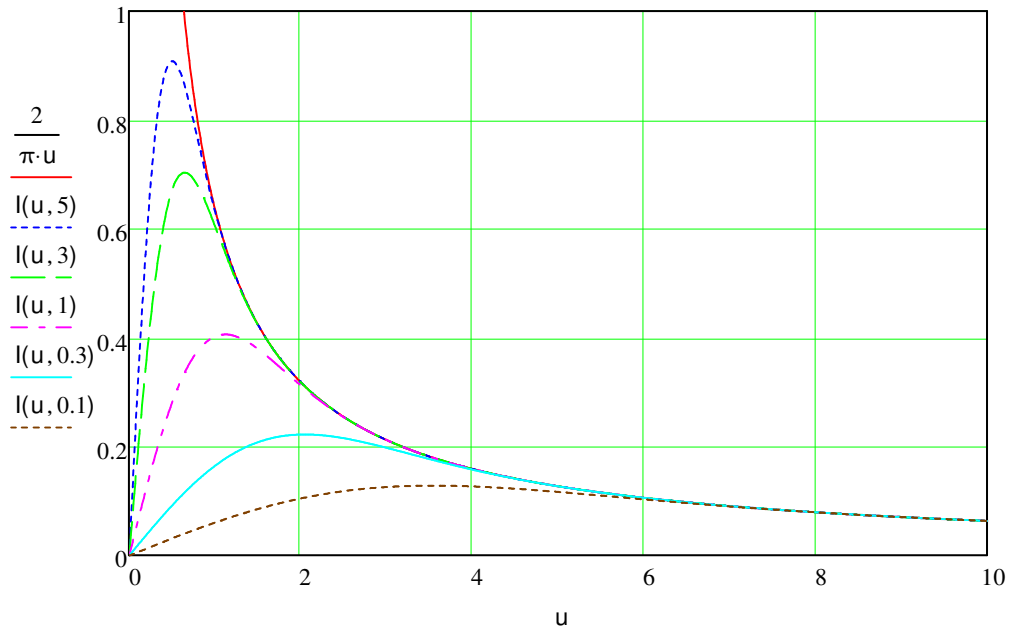

$$L(10^{-6}) = 0.83$$

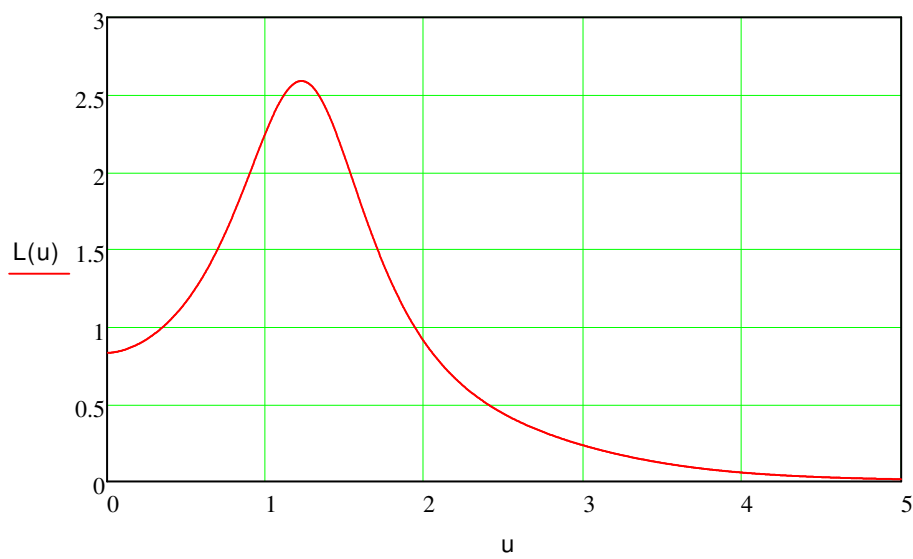

$$L(10) = 5.17 \times 10^{-4} \quad L(20) = 1.64 \times 10^{-5} \quad L(50) = 1.76 \times 10^{-7} \quad L(100) = 6.13 \times 10^{-9}$$

Inversion integral for t=3 hours

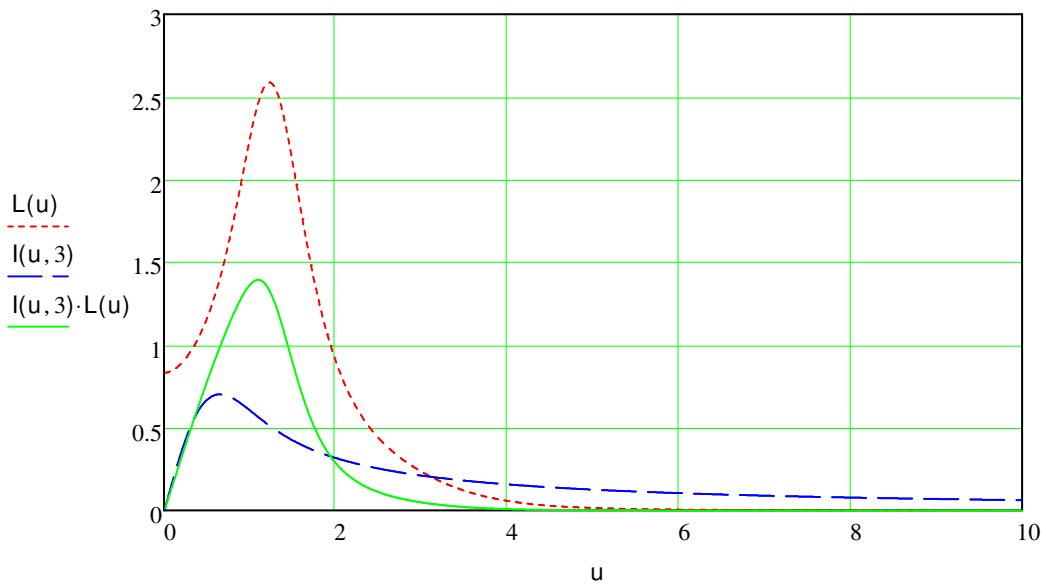
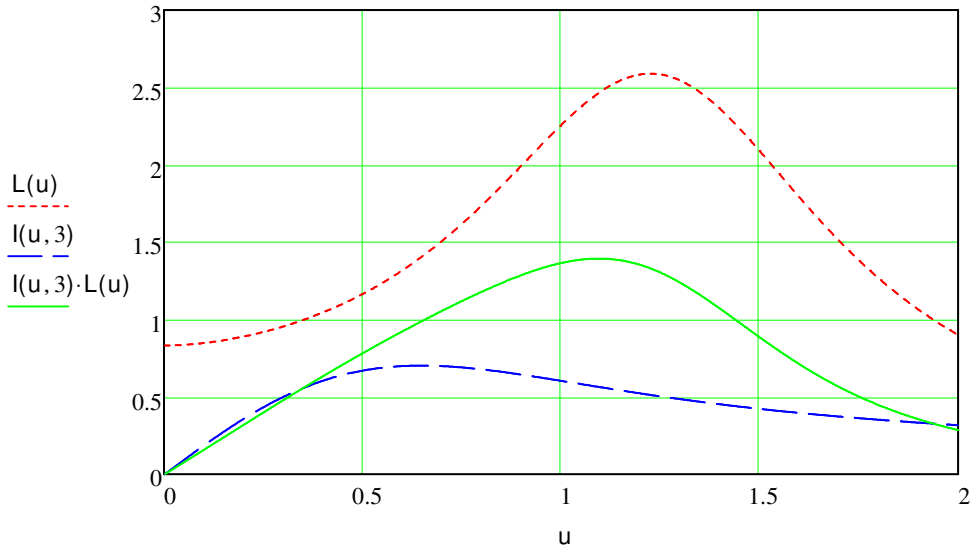

Riemann sum:
$$S := \sum_{n=1}^{1000} \left(I\left(\frac{n-0.5}{100}, 3\right) \cdot L\left(\frac{n-0.5}{100}\right) \cdot \frac{1}{100} \right)$$

$$T_f(3 \cdot 3600) = 1.8 \quad \frac{S}{T_f(3 \cdot 3600)} - 1 = -3.62 \times 10^{-5}$$

Time derivative of $T_f(t)$

$$T_{ff}(t) := \frac{2}{\pi} \cdot \int_0^{\infty} \frac{u}{t_0} \cdot e^{-u^2 \cdot \frac{t}{t_0}} \cdot L(u) \, du$$

$$T_{ff}(0) = 9.52 \times 10^{-4} \quad T_{ff}(60) = 8.79 \times 10^{-4} \quad T_{ff}(3600) = 1.49 \times 10^{-4}$$

$$T_{ff}(10 \cdot 3600) = 8.58 \times 10^{-6} \quad T_{ff}(100 \cdot 3600) = 7.51 \times 10^{-7} \quad T_{ff}(1000 \cdot 3600) = 7.39 \times 10^{-8}$$

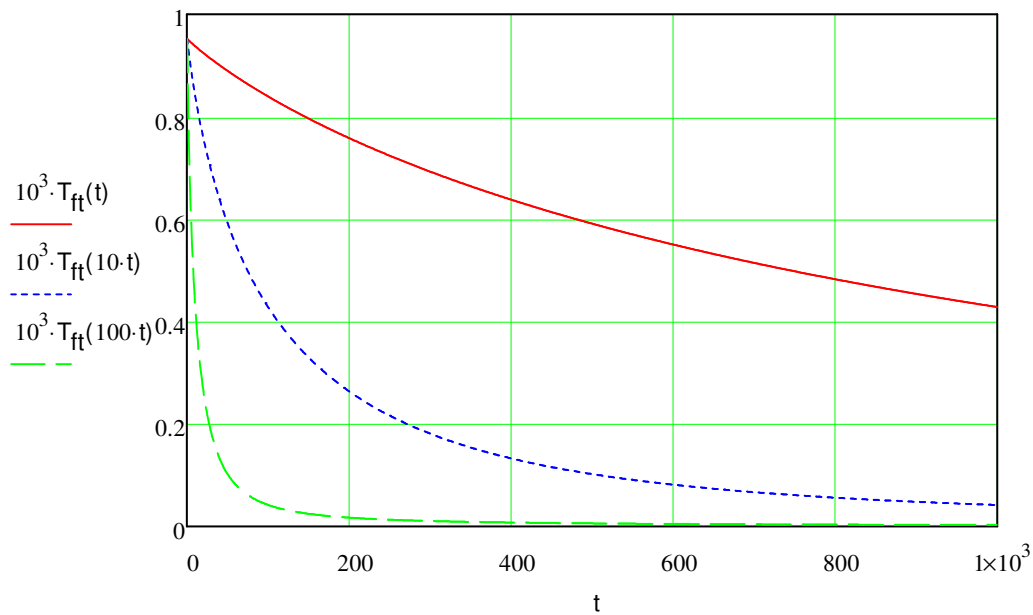

Approximation for short times

$$T_{ffs}(t) := \frac{q_{inj}}{C_p} \cdot e^{-\frac{t}{C_p \cdot R_p}} \quad \frac{q_{inj}}{C_p} = 9.52 \times 10^{-4} \quad C_p \cdot R_p = 593.8$$

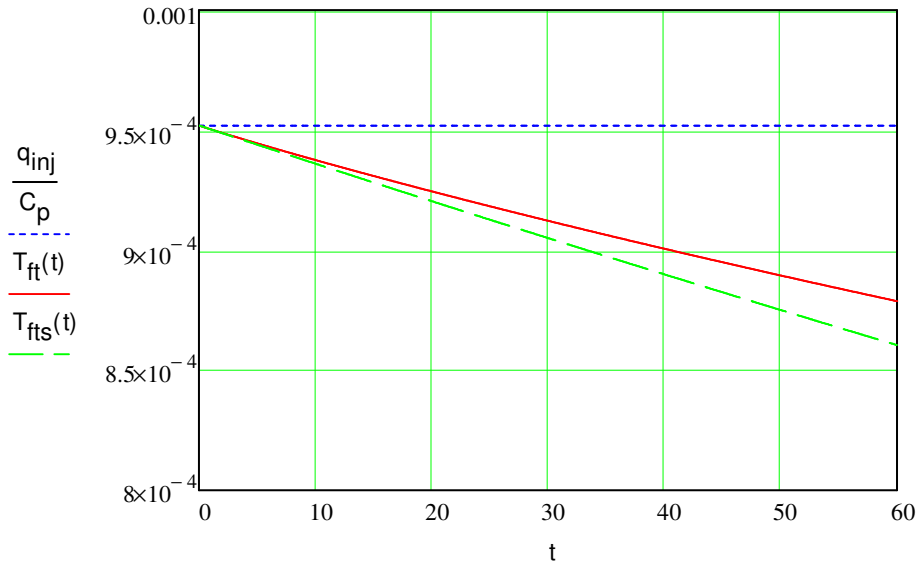

Logarithmic approximation for large times:

$$T_{fta}(t) := \frac{q_{inj}}{4 \cdot \pi \cdot \lambda} \cdot \frac{1}{t}$$

$$\frac{q_{inj}}{4 \cdot \pi \cdot \lambda} = 0.27$$

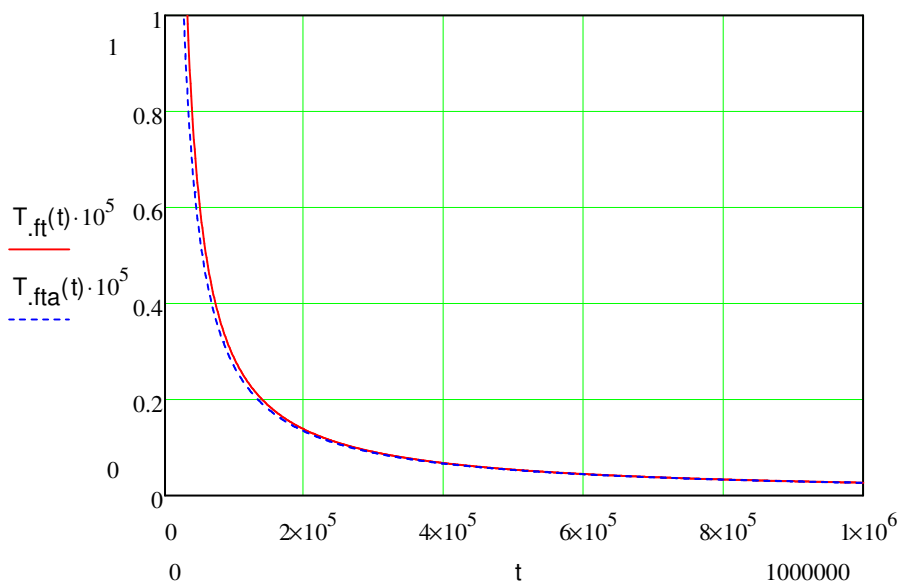

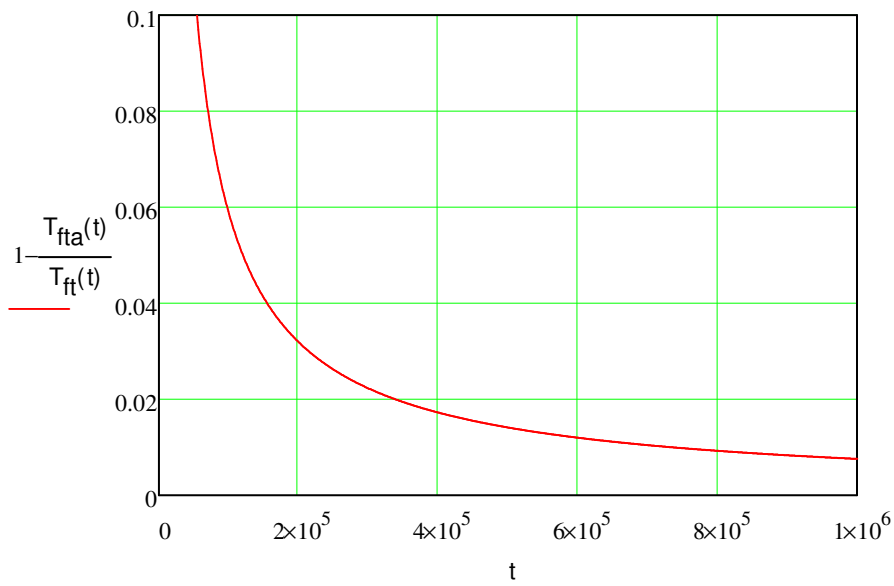

Time function in integrand of the inversion integral

$$I_t(u, t') := \frac{2}{\pi} \cdot \frac{u}{t_0} \cdot e^{-u^2 \cdot t'} \quad (t' \text{ time in hours, } t_0=3600)$$

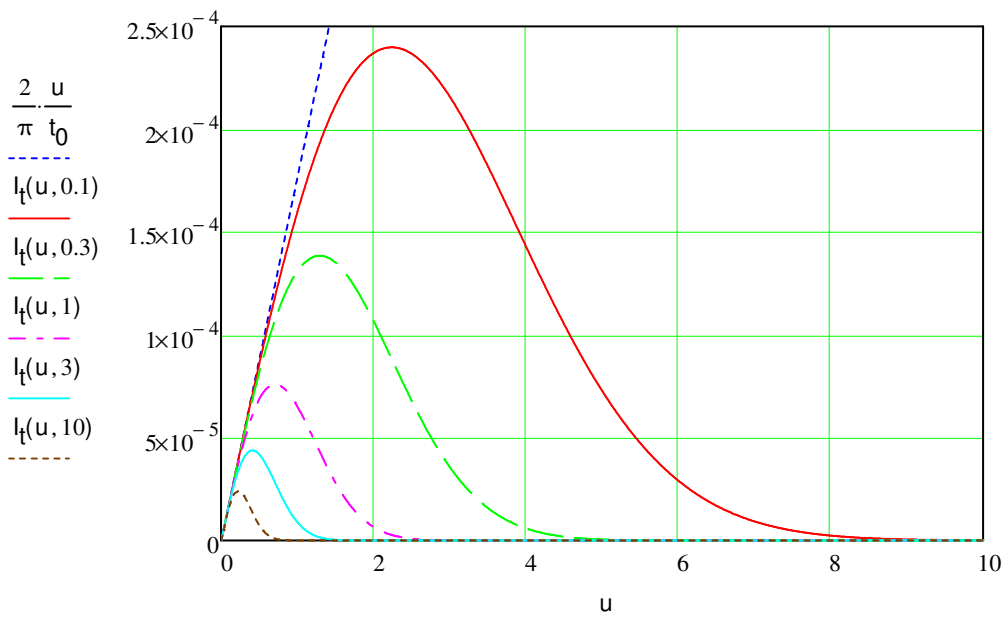

A4.2 Numerical solution for $T_f(t)$ for a pipe in borehole in ground

Pipe + borehole annulus + ground. Radial numerical solution.

J.C. Jan. 2011

Input data:

$$q_{inj} := 10 \quad \lambda_b := 1.5 \quad \rho c_b := 1550 \cdot 2000 \quad \lambda := 3.0 \quad \rho c := 2500 \cdot 750$$

$$r_p := 0.02 \cdot \sqrt{2} \quad r_b := 0.055 \quad a_b := \frac{\lambda_b}{\rho c_b} \quad a := \frac{\lambda}{\rho c} \quad C_p := \pi \cdot r_p^2 \cdot 4.18 \cdot 10^6$$

$$d_{pw} := 0.0023 \quad \lambda_p := 0.42 \quad h_p := 725 \quad R_p := \frac{1}{2 \cdot \pi \cdot \lambda_p} \cdot \ln\left(\frac{r_p}{r_p - d_{pw}}\right) + \frac{1}{2 \cdot r_p \cdot h_p}$$

$$N_b := 5 \quad t_{max} := 100 \cdot 3600$$

$$t_0 := 3600 \quad C_p = 10505.49 \quad R_p = 0.06 \quad a_b = 4.84 \times 10^{-7} \quad a = 1.6 \times 10^{-6}$$

Number of cells in the annular region and in the ground:

$$u_b := \ln\left(\frac{r_b}{r_p}\right) \quad \Delta u := \frac{u_b}{N_b} \quad N_g := 1 + \text{floor}\left(\frac{\lambda_b}{\Delta u \cdot \lambda} \cdot \ln\left(\frac{4 \cdot \sqrt{a \cdot t_{max}}}{r_b}\right)\right) \quad N := N_b + N_g \quad u_{max} := N \cdot \Delta u$$

$$u_b = 0.67 \quad \Delta u = 0.13 \quad N_g = 16 \quad N = 21 \quad u_{max} = 2.79$$

Heat capacities C_n of computational cells:

$$r_u(u) := \begin{cases} r_p \cdot e^u & \text{if } 0 \leq u \leq u_b \\ (u - u_b) \cdot \frac{\lambda}{\lambda_b} & \text{if } u > u_b \end{cases} \quad r_u(N \cdot \Delta u) = 3.88$$

$$C_n := \begin{cases} C_p & n := 1..N_b \\ \pi \cdot \left(r_u(n \cdot \Delta u)^2 - r_u(n \cdot \Delta u - \Delta u)^2 \right) \cdot \begin{cases} \rho c_b & \text{if } 1 \leq n \leq N_b \\ \rho c & \text{otherwise} \end{cases} & n := 1..N \end{cases}$$

Calculation of thermal conductances

$$K_n := \frac{1}{R_p + \frac{0.5 \cdot \Delta u}{2 \cdot \pi \cdot \lambda_b}} \quad n := 1..N - 1 \quad K_n := \frac{2 \cdot \pi \cdot \lambda_b}{\Delta u} \quad K_N := 0$$

Intrinsic time scale of the cells and stability time step:

$$n := 1..N \quad Dt_n := \frac{C_n}{K_{n-1} + K_n} \quad Dt_0 := \frac{C_0}{K_0}$$

$\Delta t_{stab} := \min(Dt) \quad \Delta t_{stab} = 21.86 \quad \Delta t := 20 \quad \text{Choice of time step!}$

Initial temperature vector including the boundary temperatures:

$$n := 0..N + 1 \quad T_n := 0$$

C =

	0
0	10505.49
1	2374.35
2	3097.93
3	4042.02
4	5273.82
5	6881.02
6	12515.35
7	21305.76
8	36270.31
9	61745.52
10	$1.05 \cdot 10^5$
11	$1.79 \cdot 10^5$
12	$3.05 \cdot 10^5$
13	$5.19 \cdot 10^5$
14	$8.83 \cdot 10^5$
15	$1.5 \cdot 10^6$
16	$2.56 \cdot 10^6$
17	$4.36 \cdot 10^6$
18	$7.41 \cdot 10^6$
19	$1.26 \cdot 10^7$
20	$2.15 \cdot 10^7$
21	$3.66 \cdot 10^7$

K =

	0
0	15.73
1	70.86
2	70.86
3	70.86
4	70.86
5	70.86
6	70.86
7	70.86
8	70.86
9	70.86
10	70.86
11	70.86
12	70.86
13	70.86
14	70.86
15	70.86
16	70.86
17	70.86
18	70.86
19	70.86
20	70.86
21	0

Dt =

	0
0	667.93
1	27.42
2	21.86
3	28.52
4	37.21
5	48.55
6	88.31
7	150.34
8	255.93
9	435.69
10	741.7
11	1262.65
12	2149.49
13	3659.24
14	6229.38
15	10604.71
16	18053.15
17	30733.15
18	52319.21
19	89066.7
20	$1.52 \cdot 10^5$
21	$5.16 \cdot 10^5$

T =

	0
0	0
1	0
2	0
3	0
4	0
5	0
6	0
7	0
8	0
9	0
10	0
11	0
12	0
13	0
14	0
15	0
16	0
17	0
18	0
19	0
20	0
21	0
22	0

Basic loop to calculate the new temperature vector after ν_{\max} time steps (or iterations) starting with an initial temperature field T:

$$\text{Tit}(T, \nu_{\max}) := \left. \begin{array}{l} T1 \leftarrow T \\ \text{for } \nu \in 1.. \nu_{\max} \\ \quad \text{for } n \in 0.. N \\ \quad \quad q_n \leftarrow K_n \cdot (T1_n - T1_{n+1}) \\ \quad \quad \text{for } n \in 1.. N \\ \quad \quad \quad T1_n \leftarrow T1_n + \frac{\Delta t}{C_n} \cdot (q_{n-1} - q_n) \\ \quad \quad T1_0 \leftarrow T1_0 + \frac{\Delta t}{C_0} \cdot (q_{\text{inj}} - q_0) \end{array} \right| T1 \quad \Delta t = 20$$

Coordinates of boundaries and cell mid-points:

$$\begin{array}{llll} u_0 := 0 & n := 1.. N & u_n := (n - 0.5) \cdot \Delta u & u_N := N \cdot \Delta u \\ r_0 := r_p & n := 1.. N & r_n := r_u(u_n) & r_{N+1} := r_u(N \cdot \Delta u) \quad r_{\max} := r_u(N \cdot \Delta u) = 3.88 \end{array}$$

A few results: $n := 0.. N + 1$

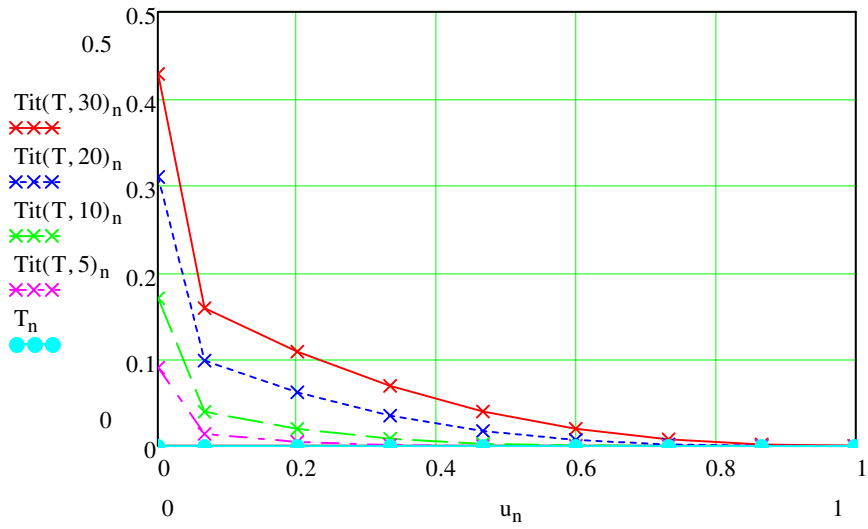

$5 \cdot \Delta t = 100$

$10 \cdot \Delta t = 200$

$20 \cdot \Delta t = 400$

$30 \cdot \Delta t = 600$

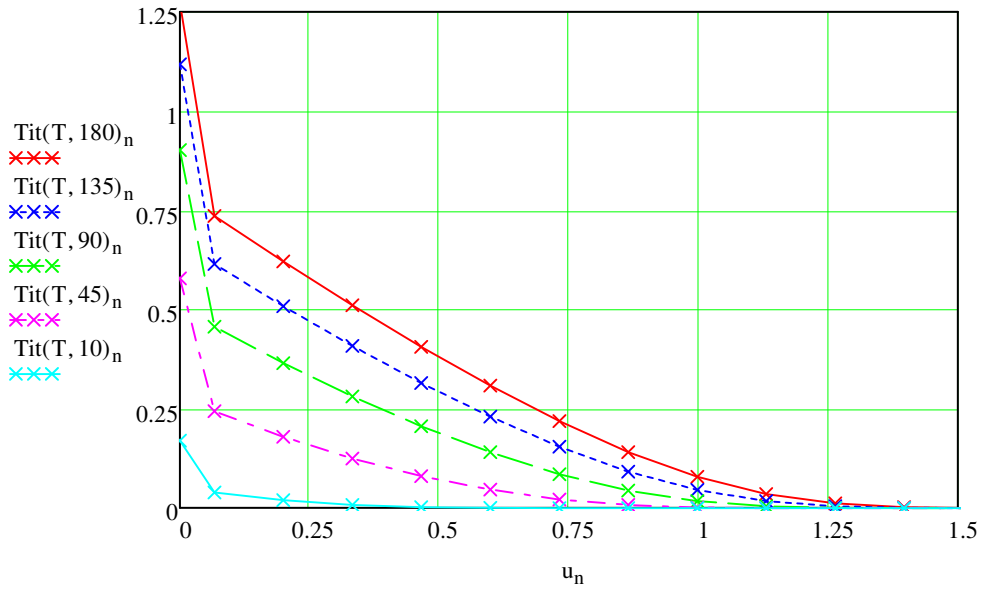

$10 \cdot \Delta t = 200$

$45 \cdot \Delta t = 900$

$90 \cdot \Delta t = 1800$

$135 \cdot \Delta t = 2700$

$180 \cdot \Delta t = 3600$

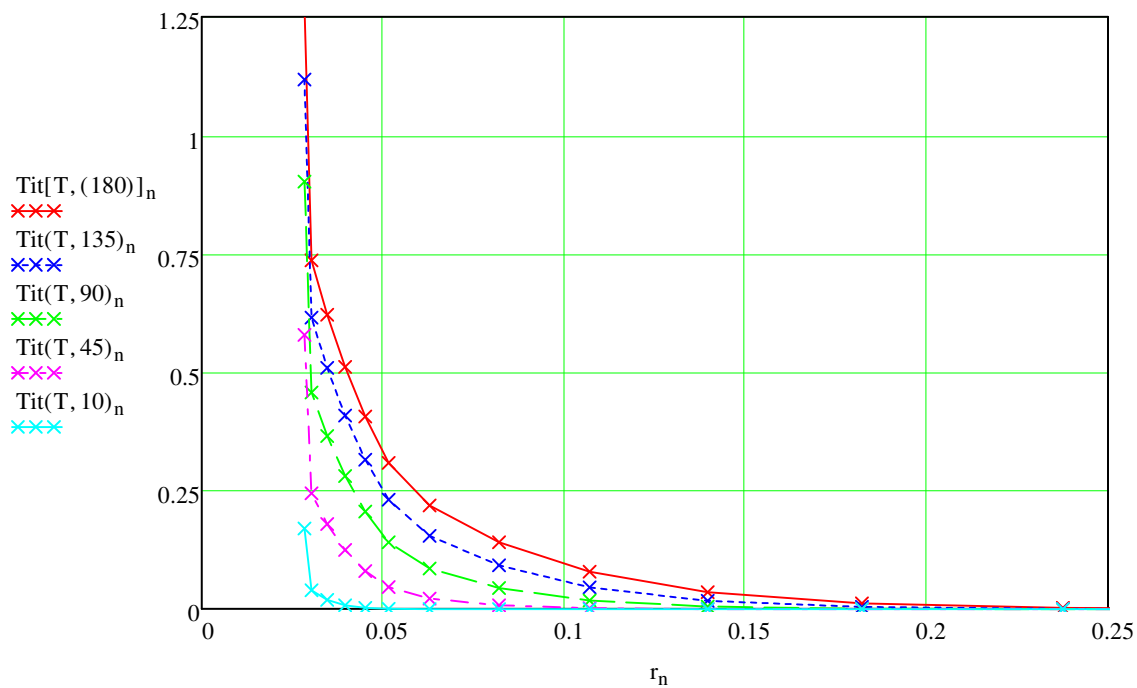

$10 \cdot \Delta t = 200$

$45 \cdot \Delta t = 900$

$90 \cdot \Delta t = 1800$

$135 \cdot \Delta t = 2700$

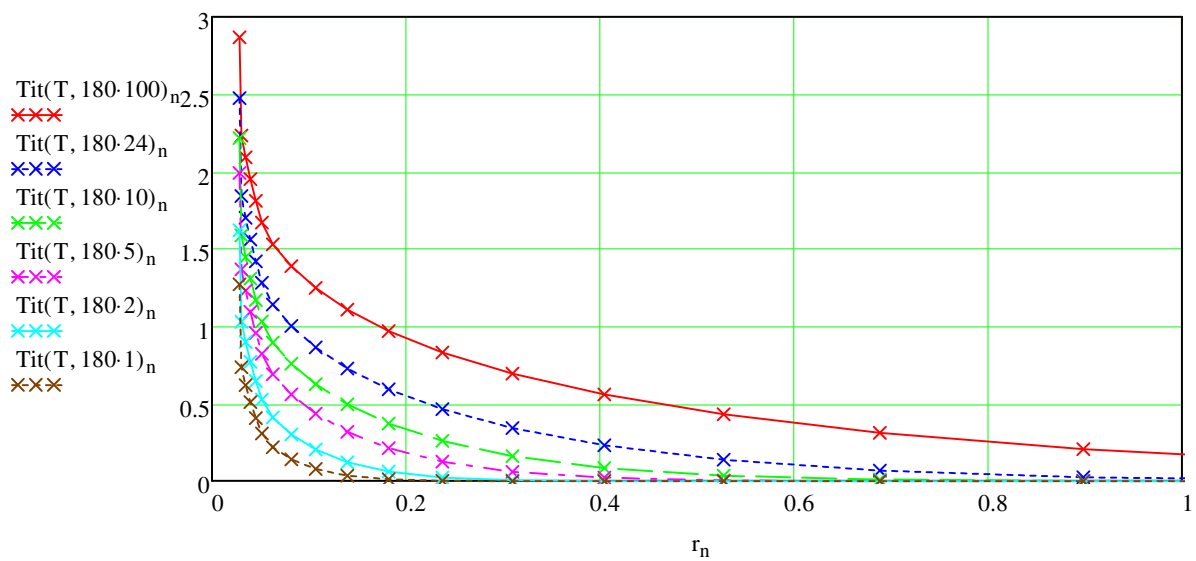

$180 \cdot \Delta t = 3600$

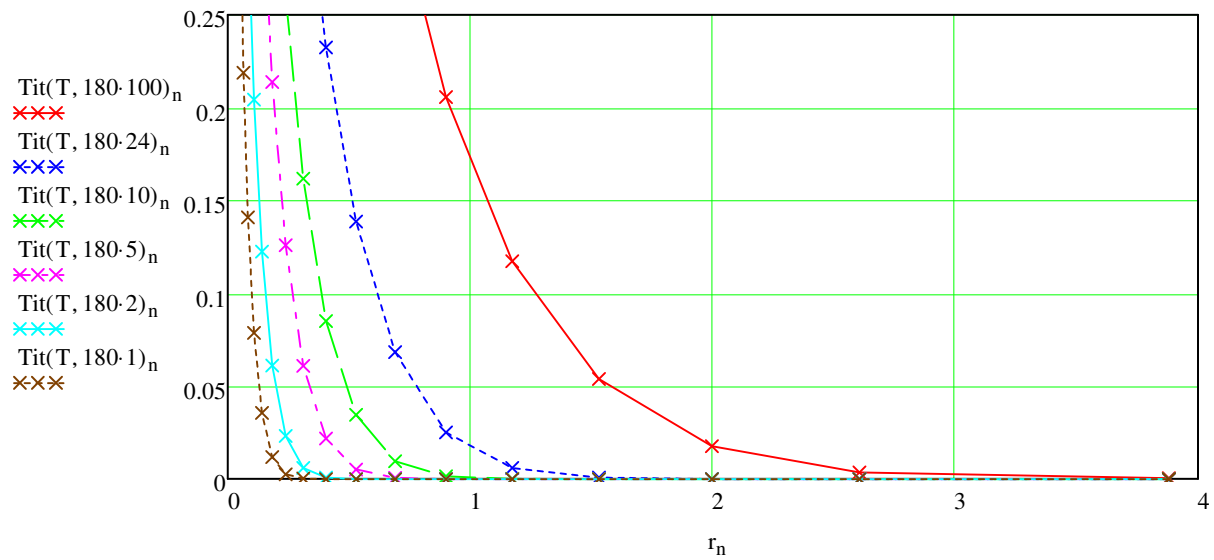

$$r_{N-1} = 2.6$$

$$r_N = 3.88$$

$$\text{Tit}(T, 180 \cdot 1)_N = 0$$

$$\text{Tit}(T, 180 \cdot 5)_N = 5.76 \times 10^{-15}$$

$$\text{Tit}(T, 180 \cdot 24)_N = 4.65 \times 10^{-8}$$

$$\text{Tit}(T, 180 \cdot 50)_N = 9.75 \times 10^{-6}$$

$$\text{Tit}(T, 180 \cdot 80)_N = 1.52 \times 10^{-4}$$

$$\text{Tit}(T, 180 \cdot 100)_N = 4.68 \times 10^{-4}$$

Printout of $T_f(t)$

$$\nu_{\max} := \text{floor}\left(\frac{t_{\max}}{\Delta t}\right)$$

$$\Delta t = 20$$

$$\nu_{\max} = 18000$$

```

Titf(T, ν_max) :=
  T1 ← T
  for ν ∈ 1..ν_max
    for n ∈ 0..N
      q_n ← K_n · (T1_n - T1_{n+1})
    for n ∈ 1..N
      T1_n ← T1_n + (Δt / C_n) · (q_{n-1} - q_n)
    T1_0 ← T1_0 + (Δt / C_0) · (q_inj - q_0)
  Tf_ν ← T1_0
  Tf

```

$$Tf := \text{Titf}(T, \nu_{\max}) \quad \nu := 0.. \nu_{\max} \quad tf_{\nu} := \frac{\Delta t \cdot \nu}{3600}$$

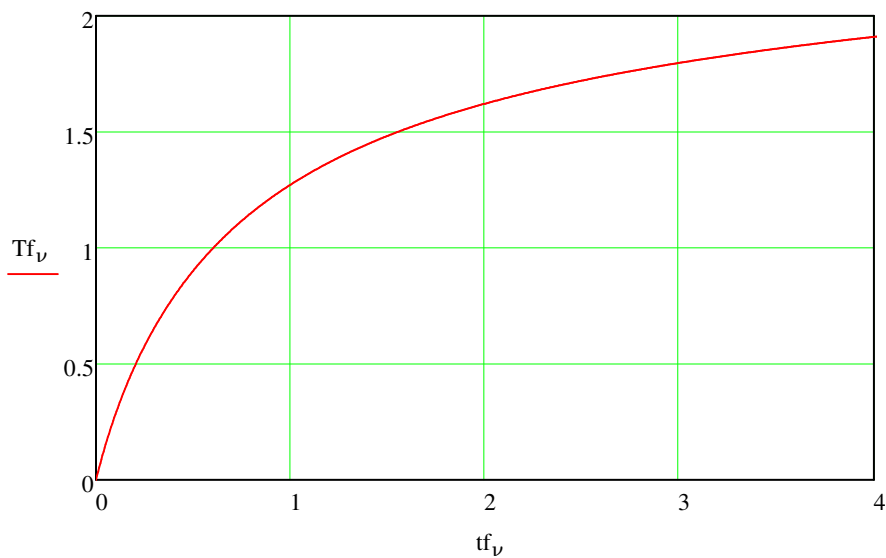
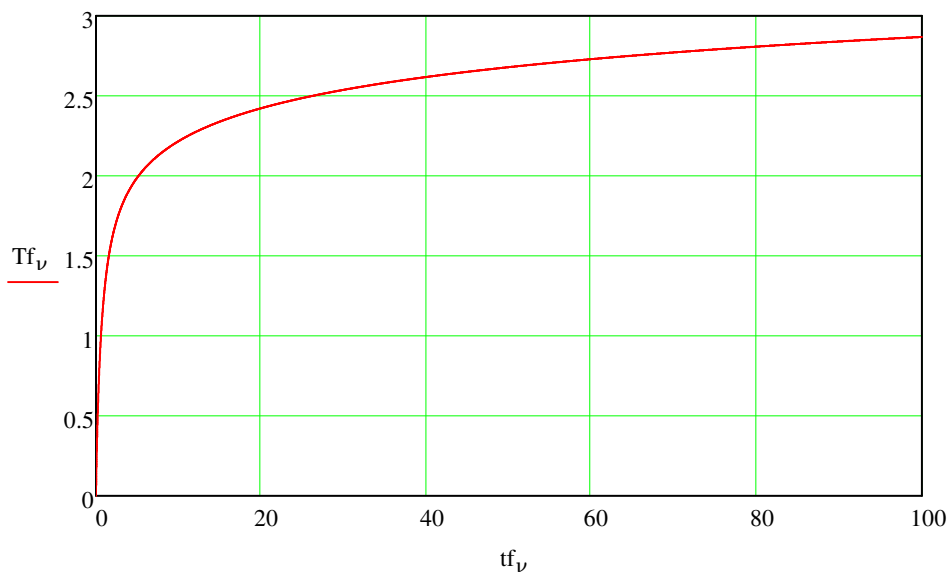

$$\nu_{\max} = 18000$$

$$r_{\max} = 3.88$$

$$\nu_1 := \text{floor}\left(\frac{0.1 \cdot 3600}{\Delta t}\right) \quad \text{Tf}_{\nu_1} = 0.2841$$

$$\nu_1 := \text{floor}\left(\frac{0.4 \cdot 3600}{\Delta t}\right) \quad \text{Tf}_{\nu_1} = 0.7905$$

$$\nu_1 := \text{floor}\left(\frac{1 \cdot 3600}{\Delta t}\right) \quad \text{Tf}_{\nu_1} = 1.2734$$

$$\nu_1 := \text{floor}\left(\frac{3 \cdot 3600}{\Delta t}\right) \quad \text{Tf}_{\nu_1} = 1.7987$$

$$\nu_1 := \text{floor}\left(\frac{10 \cdot 3600}{\Delta t}\right) \quad \text{Tf}_{\nu_1} = 2.2188$$

$$\nu_1 := \text{floor}\left(\frac{100 \cdot 3600}{\Delta t}\right) \quad \text{Tf}_{\nu_1} = 2.8702$$

Weighting function

$$\nu := 1 .. \nu_{\max} - 1$$

$$\frac{q_{\text{inj}}}{C_p} = 9.52 \times 10^{-4}$$

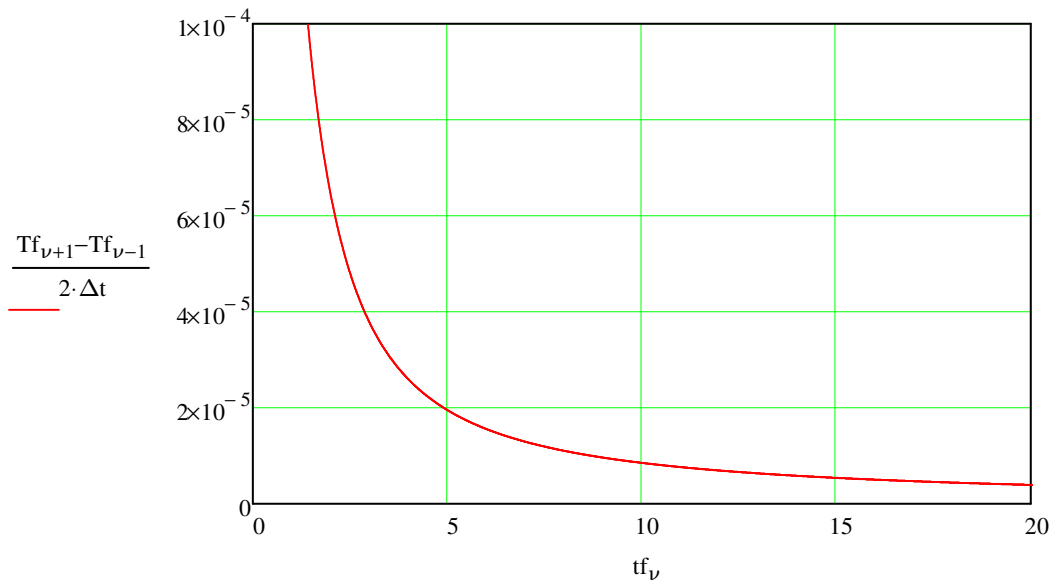
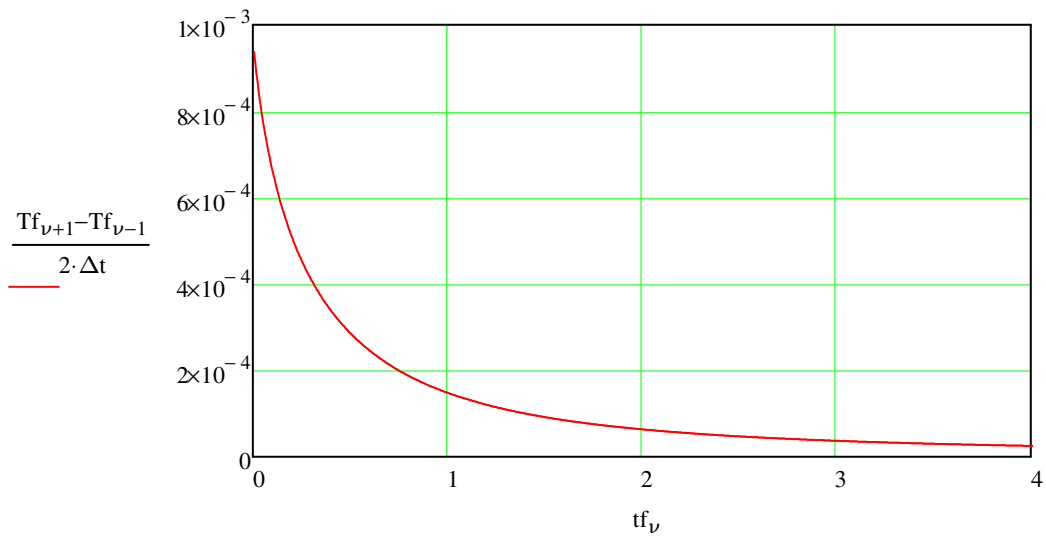

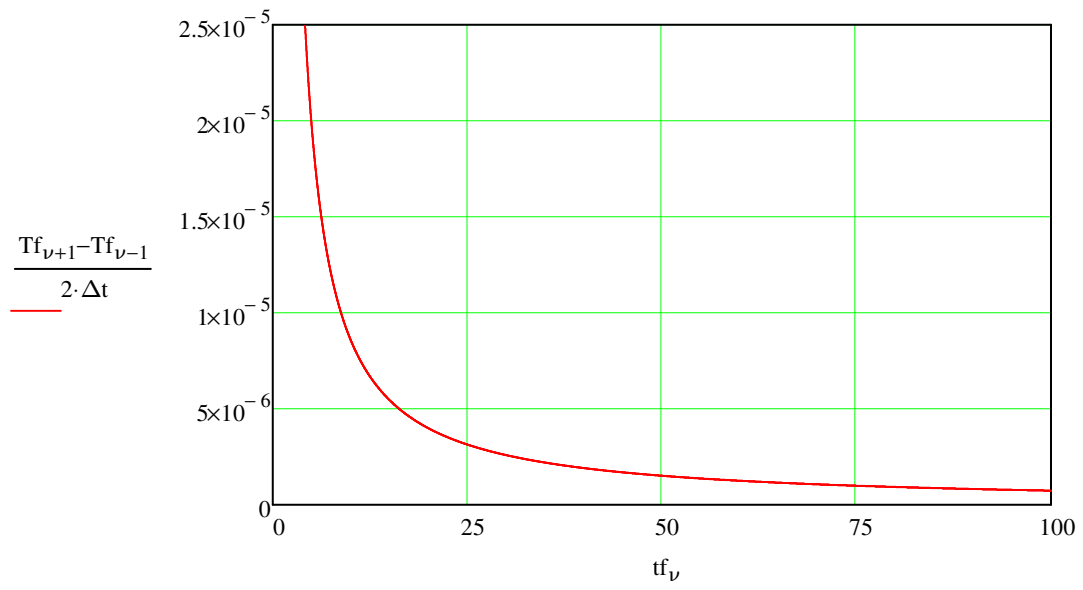

A4.3 Comparison of Laplace and numerical solution

Comparison of fluid temperature $T_f(t)$ for the basic example.

J.C. Jan. 2011

Input data:

$$q_{inj} := 10 \quad \lambda_b := 1.5 \quad \rho c_b := 1550 \cdot 2000 \quad \lambda := 3.0 \quad \rho c := 2500 \cdot 750$$

$$r_p := 0.02 \cdot \sqrt{2} \quad r_b := 0.055 \quad a_b := \frac{\lambda_b}{\rho c_b} \quad a := \frac{\lambda}{\rho c} \quad C_p := \pi \cdot r_p^2 \cdot 4.18 \cdot 10^6$$

$$d_{pw} := 0.0023 \quad \lambda_p := 0.42 \quad h_p := 725 \quad R_p := \frac{1}{2 \cdot \pi \cdot \lambda_p} \cdot \ln\left(\frac{r_p}{r_p - d_{pw}}\right) + \frac{1}{2 \cdot r_p \cdot h_p}$$

$$t_0 := 3600 \quad C_p = 1.0505 \times 10^4 \quad R_p = 0.0565 \quad a_b = 4.8387 \times 10^{-7} \quad a = 1.6 \times 10^{-6}$$

Radial Laplace solution.

$$\tau_p := \frac{r_p}{\sqrt{a_b \cdot t_0}} \quad \tau_b := \frac{r_b}{\sqrt{a_b \cdot t_0}} \quad \tau_g := \frac{r_b}{\sqrt{a \cdot t_0}}$$

$$Kb_t(u) := \frac{4 \cdot \lambda_b}{J_0(\tau_p \cdot u) \cdot Y_0(\tau_b \cdot u) - Y_0(\tau_p \cdot u) \cdot J_0(\tau_b \cdot u)} \quad (b = \text{bar})$$

$$Kb_p(u) := 4 \cdot \lambda_b \cdot \frac{0.5 \pi \cdot \tau_p \cdot u \cdot (J_1(\tau_p \cdot u) \cdot Y_0(\tau_b \cdot u) - Y_1(\tau_p \cdot u) \cdot J_0(\tau_b \cdot u)) - 1}{J_0(\tau_p \cdot u) \cdot Y_0(\tau_b \cdot u) - Y_0(\tau_p \cdot u) \cdot J_0(\tau_b \cdot u)}$$

$$Kb_b(u) := 4 \cdot \lambda_b \cdot \frac{0.5 \pi \cdot \tau_b \cdot u \cdot (J_1(\tau_b \cdot u) \cdot Y_0(\tau_p \cdot u) - Y_1(\tau_b \cdot u) \cdot J_0(\tau_p \cdot u)) - 1}{J_0(\tau_p \cdot u) \cdot Y_0(\tau_b \cdot u) - Y_0(\tau_p \cdot u) \cdot J_0(\tau_b \cdot u)}$$

$$Kb_g(u) := 2 \cdot \pi \cdot \lambda \cdot \frac{\tau_g \cdot u \cdot (J_1(\tau_g \cdot u) - i \cdot Y_1(\tau_g \cdot u))}{J_0(\tau_g \cdot u) - i \cdot Y_0(\tau_g \cdot u)}$$

$$L(u) := \text{Im} \left(\frac{-q_{inj}}{C_p \cdot \frac{-u^2}{t_0} + \frac{1}{R_p + \frac{1}{Kb_p(u) + \frac{1}{\frac{1}{Kb_t(u)} + \frac{1}{Kb_b(u) + Kb_g(u)}}}}} \right)$$

$$T_f(t) := \frac{2}{\pi} \int_0^{25} \frac{1 - e^{-u^2 \cdot \frac{t}{t_0}}}{u} \cdot L(u) \, du \quad T_f(0) = 0$$

Printout of $T_f(t)$

$$T_f(60) = 0.0548$$

$$T_f(600) = 0.4262$$

$$T_f(3600) = 1.2721$$

$$T_f(10 \cdot 3600) = 2.2206$$

$$T_f(100 \cdot 3600) = 2.8722$$

$$T_f(1000 \cdot 3600) = 3.4879$$

$$\nu_{\text{minute}_{\max}} := \frac{100 \cdot 3600}{60}$$

$$\nu_{\text{minute}_{\max}} = 6000$$

A value each minute during the first 100 hours!

$$\nu := 0 .. \nu_{\text{minute}_{\max}}$$

$$Tf_Lap_{\nu} := T_f(\nu \cdot 60)$$

$$thour_{\nu} := \frac{\nu}{60}$$

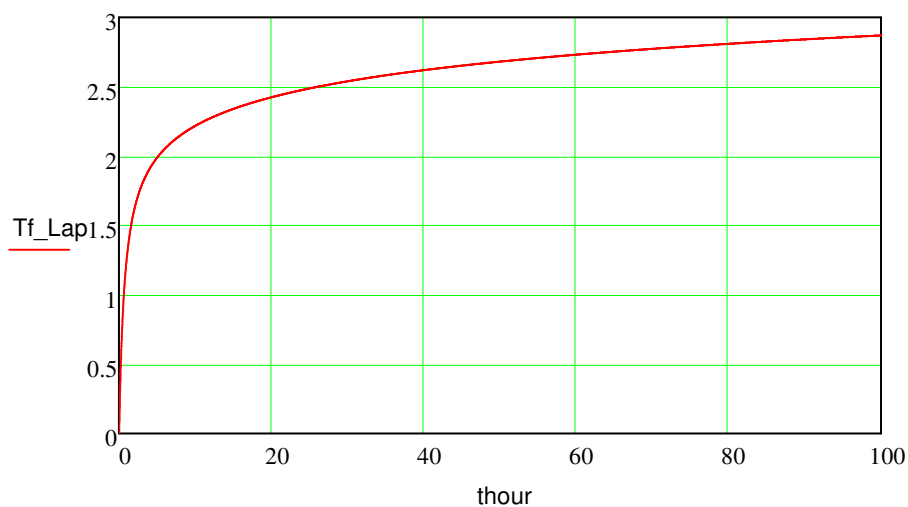

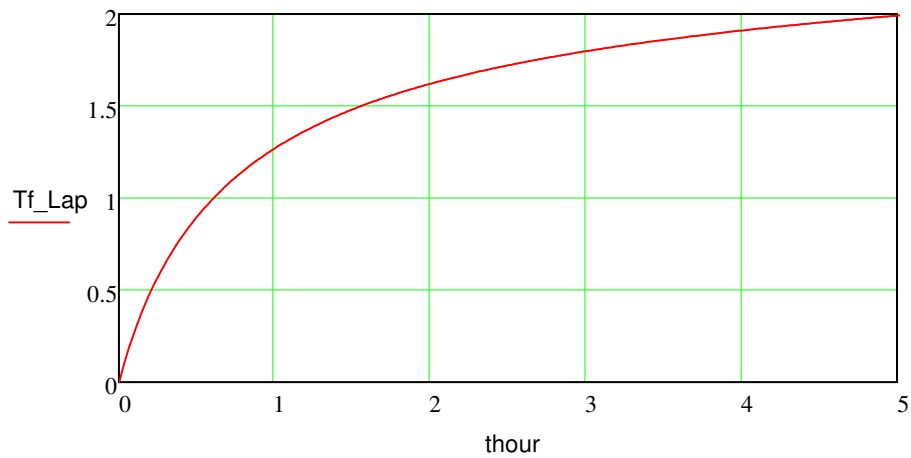

Radial numerical solution.

$$N_b := 5 \quad t_{\max} := 100 \cdot 3600$$

Other data and functions

$$u_b := \ln\left(\frac{r_b}{r_p}\right) \quad \Delta u := \frac{u_b}{N_b} \quad N_g := 1 + \text{floor}\left(\frac{\lambda_b}{\Delta u \cdot \lambda} \cdot \ln\left(\frac{4 \cdot \sqrt{a \cdot t_{\max}}}{r_b}\right)\right) \quad N := N_b + N_g$$

$$u_{\max} := N \cdot \Delta u \quad u_b = 0.665 \quad \Delta u = 0.133 \quad N_g = 16 \quad N = 21 \quad u_{\max} = 2.7931$$

$$r_u(u) := \begin{cases} r_p \cdot e^u & \text{if } 0 \leq u \leq u_b \\ r_b \cdot e^{(u-u_b) \cdot \frac{\lambda}{\lambda_b}} & \text{if } u > u_b \end{cases} \quad r_u(N \cdot \Delta u) = 3.8797$$

$$C_0 := C_p \quad n := 1..N \quad C_n := \pi \cdot \left(r_u(n \cdot \Delta u)^2 - r_u(n \cdot \Delta u - \Delta u)^2 \right) \cdot \begin{cases} \rho c_b & \text{if } 1 \leq n \leq N_b \\ \rho c & \text{otherwise} \end{cases}$$

$$K_0 := \frac{1}{R_p + \frac{0.5 \cdot \Delta u}{2 \cdot \pi \cdot \lambda_b}} \quad n := 1..N-1 \quad K_n := \frac{2 \cdot \pi \cdot \lambda_b}{\Delta u} \quad K_N := 0$$

$$n := 1..N \quad Dt_n := \frac{C_n}{K_{n-1} + K_n} \quad Dt_0 := \frac{C_0}{K_0}$$

$$\Delta t_{stab} := \min(Dt) \quad \Delta t_{stab} = 21.8595 \quad \Delta t := 20 \quad \text{Choice of time step!}$$

$$n := 0..N + 1 \quad T_n := 0$$

Printout of $T_f(t)$

$$\nu_{max} := \text{floor}\left(\frac{t_{max}}{\Delta t}\right) \quad \Delta t = 20 \quad \nu_{max} = 1.8 \times 10^4$$

$$T_{itf}(T, \nu_{max}) := \begin{array}{l} T1 \leftarrow T \\ \text{for } \nu \in 1.. \nu_{max} \\ \quad \text{for } n \in 0.. N \\ \quad \quad q_n \leftarrow K_n \cdot (T1_n - T1_{n+1}) \\ \quad \quad \text{for } n \in 1.. N \\ \quad \quad \quad T1_n \leftarrow T1_n + \frac{\Delta t}{C_n} \cdot (q_{n-1} - q_n) \\ \quad \quad T1_0 \leftarrow T1_0 + \frac{\Delta t}{C_0} \cdot (q_{inj} - q_0) \\ \quad \quad T_{f\nu} \leftarrow T1_0 \\ \text{Tf} \end{array}$$

$$Tf_num := \begin{array}{l} Tnum \leftarrow T_{itf}(T, \nu_{max}) \\ \text{for } \nu \in 0.. \nu_{minute_max} \\ \quad \nu m \leftarrow \nu \cdot \frac{\Delta t}{60} \quad \text{if } \nu \cdot \frac{\Delta t}{60} = \text{floor}\left(\nu \cdot \frac{\Delta t}{60}\right) \\ \quad Tf_num_\nu \leftarrow Tnum \cdot \frac{60}{\nu \cdot \Delta t} \\ \text{Tf_num} \end{array}$$

$$\nu_{max} = 18000$$

$$\nu_{minute_max} = 6000$$

$$\Delta t = 20 \quad \frac{60}{\Delta t} = 3$$

A value each minute!

$$Tf_num_1 = 0.0555 \quad Tf_num_{10} = 0.4289 \quad Tf_num_{60} = 1.2734$$

$$Tf_num_{10 \cdot 60} = 2.2188 \quad Tf_num_{100 \cdot 60} = 2.8702$$

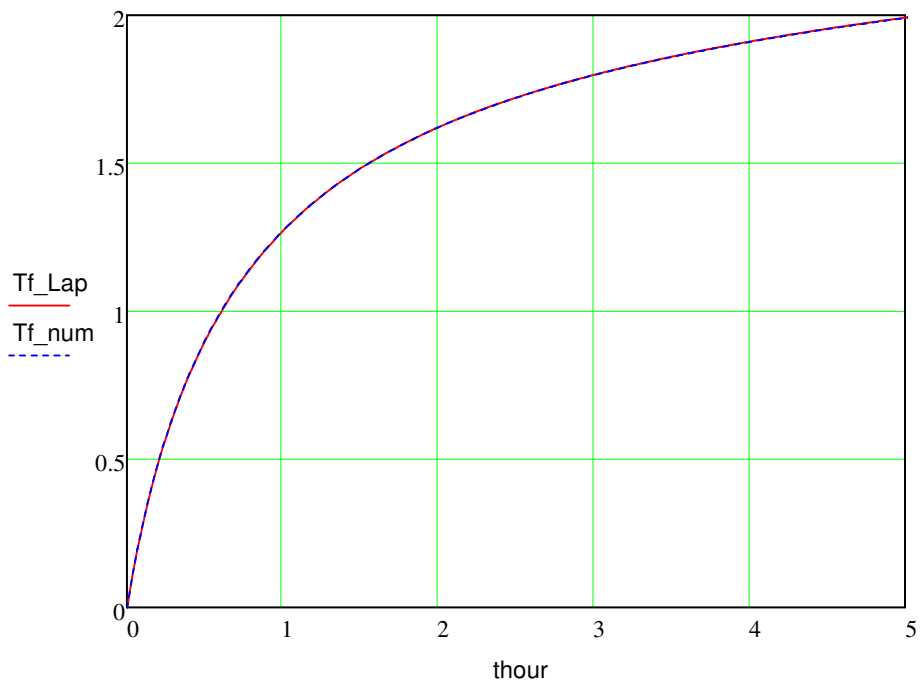
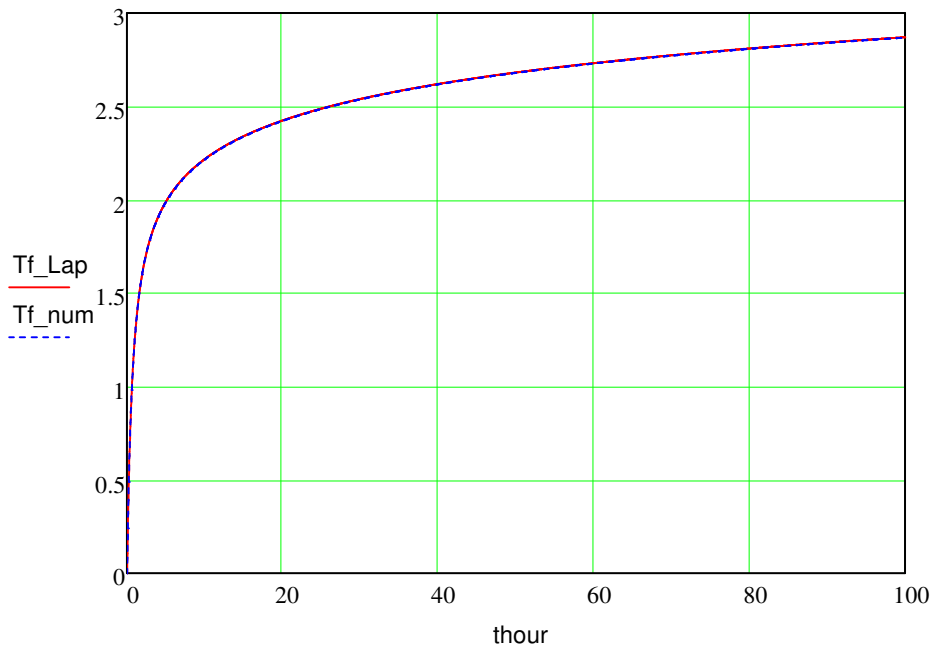

Temperature difference between Laplace and numerical solution

$Diff := Tf_num - Tf_Lap$

$N_b = 5$

$N = 21$

$\Delta t = 20$

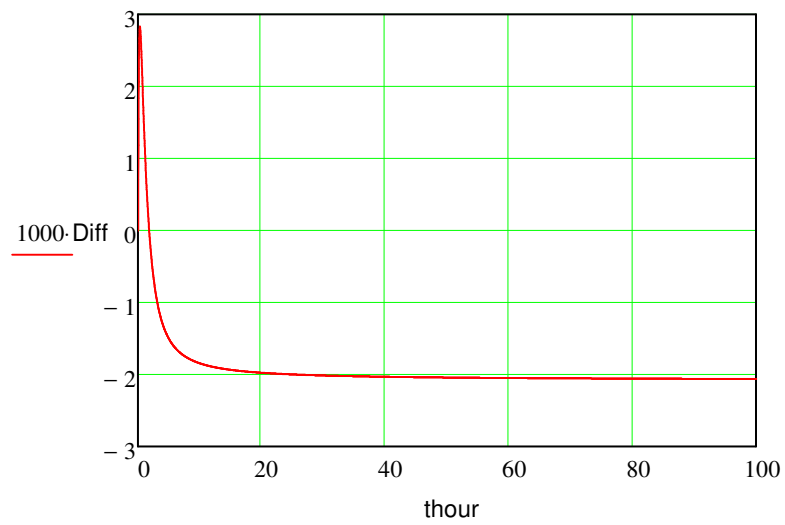
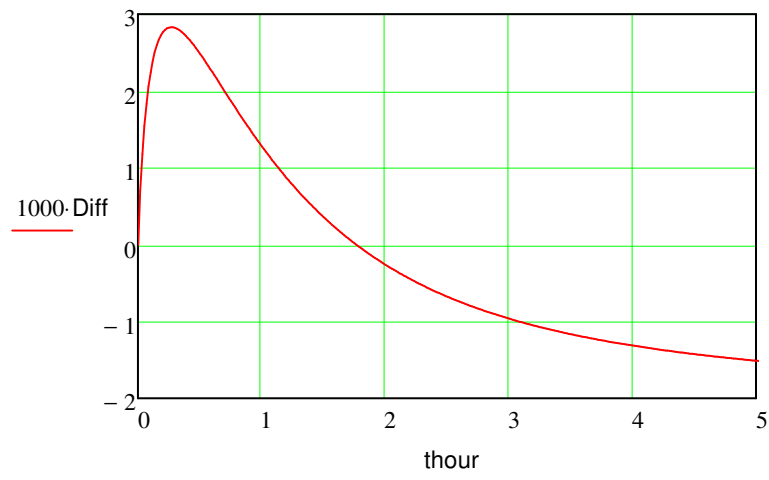
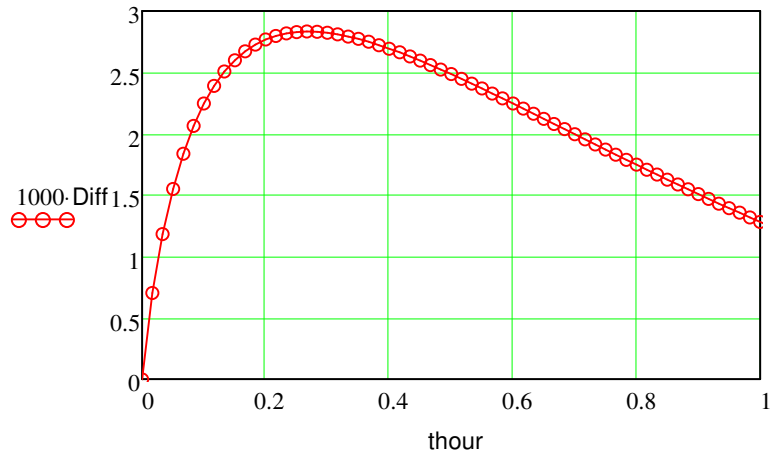

Radial numerical solution for $N_b=3$.

$$N_b := 3 \quad t_{\max} := 100 \cdot 3600$$

Other data and functions

$$u_b := \ln\left(\frac{r_b}{r_p}\right) \quad \Delta u := \frac{u_b}{N_b} \quad N_g := 1 + \text{floor}\left(\frac{\lambda_b}{\Delta u \cdot \lambda} \cdot \ln\left(\frac{4 \sqrt{a \cdot t_{\max}}}{r_b}\right)\right) \quad N := N_b + N_g$$

$$u_{\max} := N \cdot \Delta u \quad u_b = 0.665 \quad \Delta u = 0.2217 \quad N_g = 10 \quad N = 13 \quad u_{\max} = 2.8818$$

$$r_u(u) := \begin{cases} r_p \cdot e^u & \text{if } 0 \leq u \leq u_b \\ r_b \cdot e^{(u-u_b) \cdot \frac{\lambda}{\lambda_b}} & \text{if } u > u_b \end{cases} \quad r_u(N \cdot \Delta u) = 4.6325$$

$$C_0 := C_p \quad n := 1..N \quad C_n := \pi \cdot \left(r_u(n \cdot \Delta u)^2 - r_u(n \cdot \Delta u - \Delta u)^2 \right) \cdot \begin{cases} \rho c_b & \text{if } 1 \leq n \leq N_b \\ \rho c & \text{otherwise} \end{cases}$$

$$K_0 := \frac{1}{R_p + \frac{0.5 \cdot \Delta u}{2 \cdot \pi \cdot \lambda_b}} \quad n := 1..N-1 \quad K_n := \frac{2 \cdot \pi \cdot \lambda_b}{\Delta u} \quad K_N := 0$$

$$n := 1..N \quad Dt_n := \frac{C_n}{K_{n-1} + K_n} \quad Dt_0 := \frac{C_0}{K_0}$$

$$\Delta t_{\text{stab}} := \min(Dt) \quad \Delta t_{\text{stab}} = 76.0455 \quad \Delta t := 60 \quad \text{Choice of time step!}$$

$$n := 0..N+1 \quad T_n := 0$$

Printout of $T_f(t)$

$$\nu_{\max} := \text{floor}\left(\frac{t_{\max}}{\Delta t}\right) \quad \Delta t = 60 \quad \nu_{\max} = 6000$$

```

Tiff(T, νmax) :=
  T1 ← T
  for ν ∈ 1..νmax
    for n ∈ 0..N
      qn ← Kn · (T1n - T1n+1)
    for n ∈ 1..N
      T1n ← T1n +  $\frac{\Delta t}{C_n} \cdot (q_{n-1} - q_n)$ 
    T10 ← T10 +  $\frac{\Delta t}{C_0} \cdot (q_{inj} - q_0)$ 
    Tfν ← T10
  Tf

```

```

Tf_num3 :=
  Tnum ← Tiff(T, νmax)
  for ν ∈ 0..νminute_max
    νm ← ν ·  $\frac{\Delta t}{60}$  if ν ·  $\frac{\Delta t}{60} = \text{floor}\left(\nu \cdot \frac{\Delta t}{60}\right)$ 
    Tfnum_ν ← Tnum ·  $\frac{60}{\nu \cdot \frac{\Delta t}{60}}$ 
  Tf_num

```

$\nu_{\max} = 6000$
 $\nu_{\text{minute}_{\max}} = 6000$
 $\Delta t = 60 \quad \frac{60}{\Delta t} = 1$
 A value each minute!

Temperature difference between Laplace and numerical solution

Diff3 := Tf_num3 - Tf_Lap N_b = 3 N = 13 Δt = 60

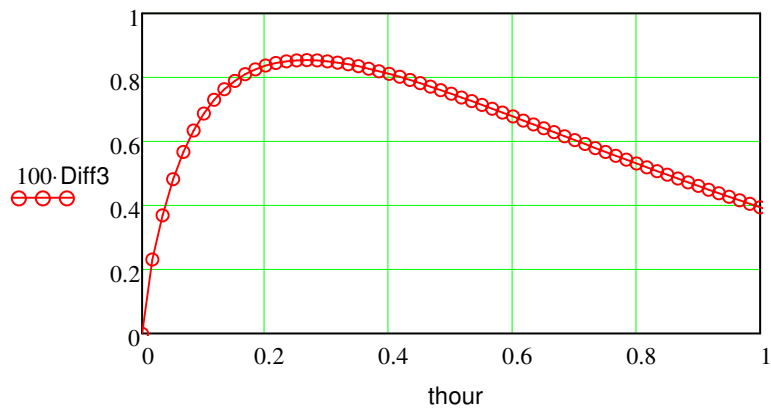

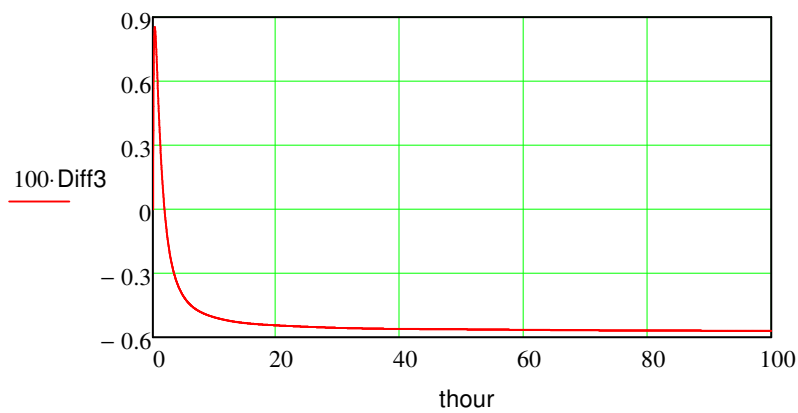
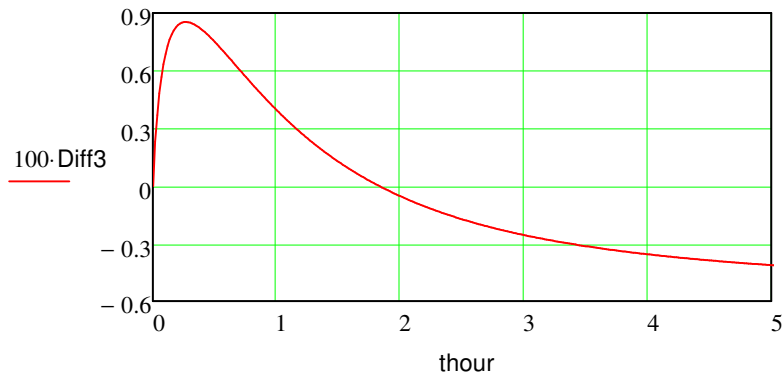

Radial numerical solution for $N_b=10$.

$N_b := 10$ $t_{max} := 100 \cdot 3600$

Other data and functions

$$u_b := \ln\left(\frac{r_b}{r_p}\right) \quad \Delta u := \frac{u_b}{N_b} \quad N_g := 1 + \text{floor}\left(\frac{\lambda_b}{\Delta u \cdot \lambda} \cdot \ln\left(\frac{4 \cdot \sqrt{a \cdot t_{max}}}{r_b}\right)\right) \quad N := N_b + N_g$$

$u_{max} := N \cdot \Delta u$ $u_b = 0.665$ $\Delta u = 0.0665$ $N_g = 31$ $N = 41$ $u_{max} = 2.7266$

$$r_u(u) := \begin{cases} r_p \cdot e^u & \text{if } 0 \leq u \leq u_b \\ r_b \cdot e^{(u-u_b) \cdot \frac{\lambda}{\lambda_b}} & \text{if } u > u_b \end{cases} \quad r_u(N \cdot \Delta u) = 3.3965$$

$$C_0 := C_p \quad n := 1..N \quad C_n := \pi \cdot \left(r_u(n \cdot \Delta u)^2 - r_u(n \cdot \Delta u - \Delta u)^2 \right) \cdot \begin{cases} \rho c_b & \text{if } 1 \leq n \leq N_b \\ \rho c & \text{otherwise} \end{cases}$$

$$K_0 := \frac{1}{R_p + \frac{0.5 \cdot \Delta u}{2 \cdot \pi \cdot \lambda_b}} \quad n := 1..N-1 \quad K_n := \frac{2 \cdot \pi \cdot \lambda_b}{\Delta u} \quad K_N := 0$$

$$n := 1..N \quad Dt_n := \frac{C_n}{K_{n-1} + K_n} \quad Dt_0 := \frac{C_0}{K_0}$$

$$\Delta t_{\text{stab}} := \min(Dt) \quad \Delta t_{\text{stab}} = 4.4666 \quad \Delta t := 4 \quad \text{Choice of time step!}$$

$$n := 0..N+1 \quad T_n := 0$$

Printout of $T_f(t)$

$$\nu_{\text{max}} := \text{floor}\left(\frac{t_{\text{max}}}{\Delta t}\right) \quad \Delta t = 4 \quad \nu_{\text{max}} = 9 \times 10^4$$

$$\text{Tiff}(T, \nu_{\text{max}}) := \begin{array}{l} T1 \leftarrow T \\ \text{for } \nu \in 1.. \nu_{\text{max}} \\ \quad \text{for } n \in 0..N \\ \quad \quad q_n \leftarrow K_n \cdot (T1_n - T1_{n+1}) \\ \quad \quad \text{for } n \in 1..N \\ \quad \quad \quad T1_n \leftarrow T1_n + \frac{\Delta t}{C_n} \cdot (q_{n-1} - q_n) \\ \quad \quad T1_0 \leftarrow T1_0 + \frac{\Delta t}{C_0} \cdot (q_{\text{inj}} - q_0) \\ \quad T1_\nu \leftarrow T1_0 \\ \text{Tf} \end{array}$$

$$\text{Tf_num10} := \begin{array}{l} Tnum \leftarrow \text{Tiff}(T, \nu_{\text{max}}) \\ \text{for } \nu \in 0.. \nu_{\text{minute_max}} \\ \quad \nu m \leftarrow \nu \cdot \frac{\Delta t}{60} \quad \text{if } \nu \cdot \frac{\Delta t}{60} = \text{floor}\left(\nu \cdot \frac{\Delta t}{60}\right) \\ \quad Tf_num_\nu \leftarrow Tnum \cdot \frac{60}{\nu \cdot \Delta t} \\ \text{Tf_num} \end{array}$$

$$\nu_{\text{max}} = 90000$$

$$\nu_{\text{minute_max}} = 6000$$

$$\Delta t = 4 \quad \frac{60}{\Delta t} = 15$$

A value each minute!

Temperature difference between Laplace and numerical solution

$\text{Diff10} := T_{f_num10} - T_{f_Lap}$ $N_b = 10$ $N = 41$ $\Delta t = 4$

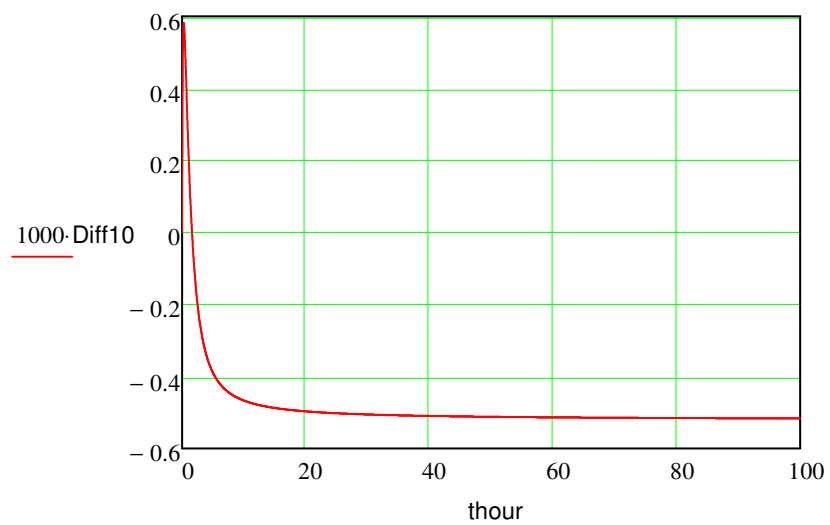
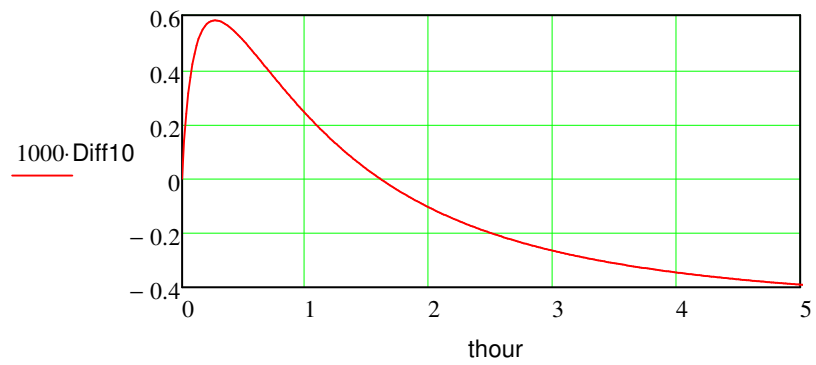
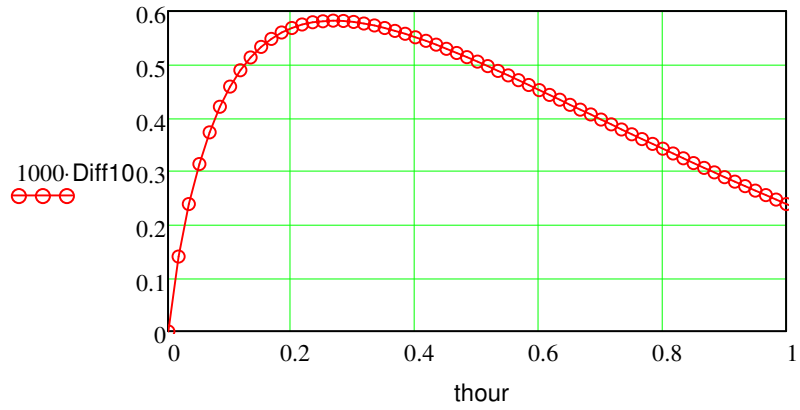

Error for 3, 5 and 10 cells in the annular borehole region

Diff3: Nb=3, N=13; Diff: Nb=5, N=21; Diff10: Nb=10, N=41;

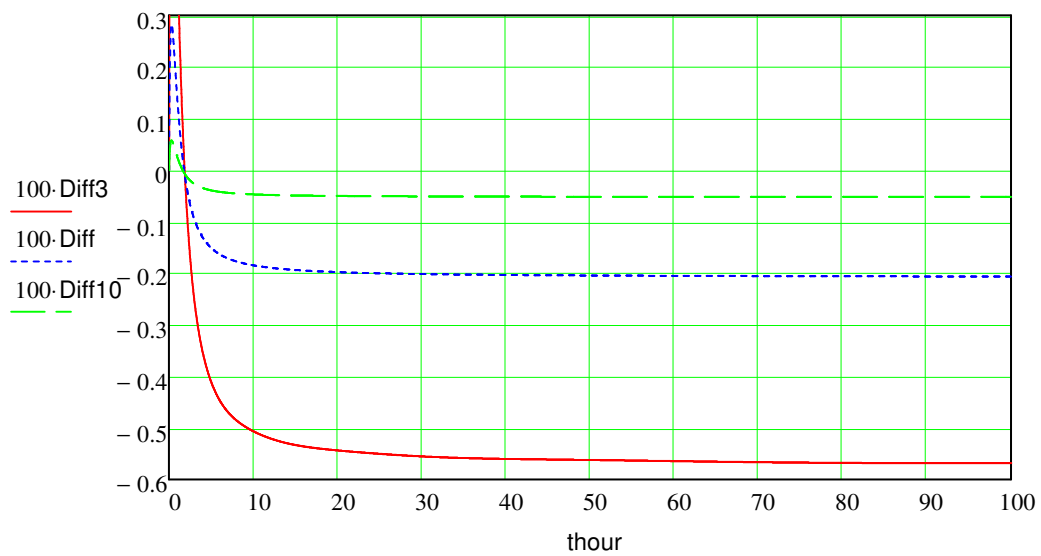
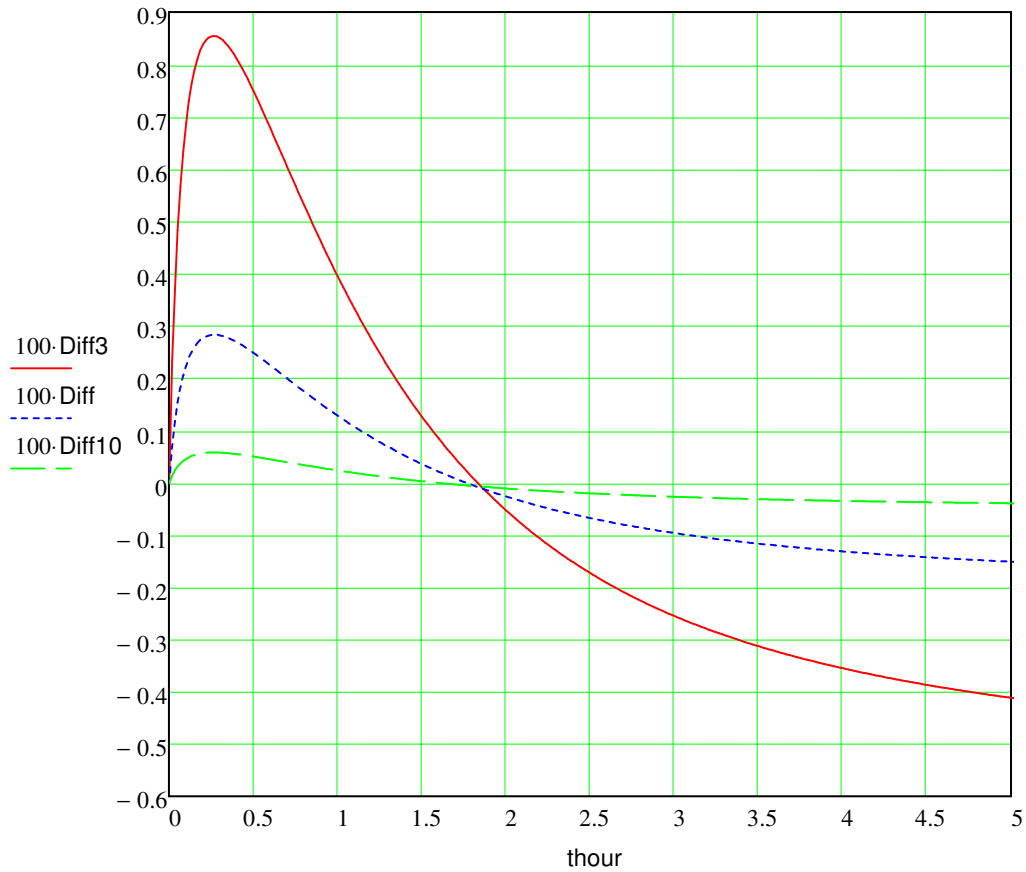

A4.4 Studies and comparisons in the Laplace domain

Step-response for borehole with pipe, annular grout and surrounding ground. Constant heat injection rate to the pipe fluid. Basic example.

Input data:

J.C. Jan. 2011

$$q_{inj} := 10 \quad \lambda_b := 1.5 \quad \rho c_b := 1550 \cdot 2000 \quad \lambda := 3.0 \quad \rho c := 2500 \cdot 750$$

$$r_p := 0.02 \cdot \sqrt{2} \quad r_b := 0.055 \quad a_b := \frac{\lambda_b}{\rho c_b} \quad a := \frac{\lambda}{\rho c} \quad C_p := \pi \cdot r_p^2 \cdot 4.18 \cdot 10^6$$

$$d_{pw} := 0.0023 \quad \lambda_p := 0.42 \quad h_p := 725 \quad R_p := \frac{1}{2 \cdot \pi \cdot \lambda_p} \cdot \ln\left(\frac{r_p}{r_p - d_{pw}}\right) + \frac{1}{2 \cdot r_p \cdot h_p}$$

$$t_0 := 3600 \quad C_p = 1.05 \times 10^4 \quad R_p = 0.06 \quad a_b = 4.84 \times 10^{-7} \quad a = 1.6 \times 10^{-6}$$

Thermal resistances:

$$\tau_p := \frac{r_p}{\sqrt{a_b \cdot t_0}} \quad \tau_b := \frac{r_b}{\sqrt{a_b \cdot t_0}} \quad \tau_g := \frac{r_b}{\sqrt{a \cdot t_0}}$$

$$Kb_t(u) := \frac{4 \cdot \lambda_b}{J_0(\tau_p \cdot u) \cdot Y_0(\tau_b \cdot u) - Y_0(\tau_p \cdot u) \cdot J_0(\tau_b \cdot u)} \quad (b = \text{bar})$$

$$Kb_p(u) := 4 \cdot \lambda_b \cdot \frac{0.5 \pi \cdot \tau_p \cdot u \cdot (J_1(\tau_p \cdot u) \cdot Y_0(\tau_b \cdot u) - Y_1(\tau_p \cdot u) \cdot J_0(\tau_b \cdot u)) - 1}{J_0(\tau_p \cdot u) \cdot Y_0(\tau_b \cdot u) - Y_0(\tau_p \cdot u) \cdot J_0(\tau_b \cdot u)}$$

$$Kb_b(u) := 4 \cdot \lambda_b \cdot \frac{0.5 \pi \cdot \tau_b \cdot u \cdot (J_1(\tau_b \cdot u) \cdot Y_0(\tau_p \cdot u) - Y_1(\tau_b \cdot u) \cdot J_0(\tau_p \cdot u)) - 1}{J_0(\tau_p \cdot u) \cdot Y_0(\tau_b \cdot u) - Y_0(\tau_p \cdot u) \cdot J_0(\tau_b \cdot u)}$$

$$Kb_g(u) := 2 \cdot \pi \cdot \lambda \cdot \frac{\tau_g \cdot u \cdot (J_1(\tau_g \cdot u) - i \cdot Y_1(\tau_g \cdot u))}{J_0(\tau_g \cdot u) - i \cdot Y_0(\tau_g \cdot u)}$$

Laplace transform and inversion integral:

$$L(u) := \text{Im} \left(\frac{-q_{inj}}{C_p \cdot \frac{-u^2}{t_0} + \frac{1}{R_p + \frac{1}{Kb_p(u) + \frac{1}{\frac{1}{Kb_t(u)} + \frac{1}{Kb_b(u) + Kb_g(u)}}}}} \right)$$

$$T_f(t) := \frac{2}{\pi} \cdot \int_0^{\infty} \frac{1 - e^{-u^2 \cdot \frac{t}{t_0}}}{u} \cdot L(u) \, du \quad T_f(0) = 0 \quad T_f(60) = 0.05 \quad T_f(600) = 0.43$$

$$T_f(3600) = 1.27 \quad T_f(10 \cdot 3600) = 2.22 \quad T_f(100 \cdot 3600) = 2.87 \quad T_f(1000 \cdot 3600) = 3.49$$

Thermal resistances (Laplace transforms):

$$\sigma_p(s) := r_p \cdot \sqrt{\frac{s}{a_b}} \quad \sigma_b(s) := r_b \cdot \sqrt{\frac{s}{a_b}} \quad \sigma_g(s) := r_b \cdot \sqrt{\frac{s}{a}}$$

Ground region outside the borehole: $K_g(s) := 2 \cdot \pi \cdot \lambda \cdot \frac{\sigma_g(s) \cdot K1(\sigma_g(s))}{K0(\sigma_g(s))}$

Borehole annulus:

$$K_t(s) := \frac{2 \cdot \pi \cdot \lambda_b}{K0(\sigma_p(s)) \cdot I0(\sigma_b(s)) - I0(\sigma_p(s)) \cdot K0(\sigma_b(s))} \quad \text{Transmittive}$$

$$K_p(s) := 2 \cdot \pi \cdot \lambda_b \cdot \frac{\sigma_p(s) \cdot (I1(\sigma_p(s)) \cdot K0(\sigma_b(s)) + K1(\sigma_p(s)) \cdot I0(\sigma_b(s))) - 1}{K0(\sigma_p(s)) \cdot I0(\sigma_b(s)) - I0(\sigma_p(s)) \cdot K0(\sigma_b(s))} \quad \text{Absorptive at } r=r_p$$

$$K_b(s) := 2 \cdot \pi \cdot \lambda_b \cdot \frac{\sigma_b(s) \cdot (I1(\sigma_b(s)) \cdot K0(\sigma_p(s)) + K1(\sigma_b(s)) \cdot I0(\sigma_p(s))) - 1}{K0(\sigma_p(s)) \cdot I0(\sigma_b(s)) - I0(\sigma_p(s)) \cdot K0(\sigma_b(s))} \quad \text{Absorptive at } r=r_b$$

Control that the conductances are the same on the negative real axis

$$u1 := 0.8 \quad s1 := \frac{-u1^2}{t_0}$$

$$Kb_p(u1) = -1.55$$

$$Kb_p(u1) - K_p(s1) = 0$$

$$Kb_b(u1) = -2.39$$

$$Kb_b(u1) - K_b(s1) = 1.73i \times 10^{-15}$$

$$Kb_t(u1) = 14.82$$

$$Kb_t(u1) - K_t(s1) = -7.11 \times 10^{-15}$$

$$Kb_g(u1) = 7.89 + 12.58i$$

$$Kb_g(u1) - K_g(s1) = -1.78i \times 10^{-15}$$

$$u1 := 0.001 \quad s1 := \frac{-u1^2}{t_0}$$

$$Kb_p(u1) = -2.36 \times 10^{-6}$$

$$Kb_p(u1) - K_p(s1) = 3.15 \times 10^{-15}$$

$$Kb_b(u1) = -3.66 \times 10^{-6}$$

$$Kb_b(u1) - K_b(s1) = 1.57 \times 10^{-15}$$

$$Kb_t(u1) = 14.17$$

$$Kb_t(u1) - K_t(s1) = 0$$

$$Kb_g(u1) = 2.45 + 0.52i$$

$$Kb_g(u1) - K_g(s1) = 0$$

$$u1 := 14 \quad s1 := \frac{-u1^2}{t_0}$$

$$Kb_p(u1) = -460.25$$

$$Kb_p(u1) - K_p(s1) = 7.96 \times 10^{-13} - 8.73i \times 10^{-13}$$

$$Kb_b(u1) = -641.31$$

$$Kb_b(u1) - K_b(s1) = 2.27 \times 10^{-13} - 1.56i \times 10^{-12}$$

$$Kb_t(u1) = 282.84$$

$$Kb_t(u1) - K_t(s1) = -3.98 \times 10^{-13} + 5.6i \times 10^{-13}$$

$$Kb_g(u1) = 9.4 + 191.47i$$

$$Kb_g(u1) - K_g(s1) = 1.79 \times 10^{-13} + 2.84i \times 10^{-14}$$

$$L_S(s) := \text{Im} \left(\frac{-q_{inj}}{C_p \cdot s + \frac{1}{R_p + \frac{1}{K_p(s) + \frac{1}{\frac{1}{K_t(s)} + \frac{1}{K_b(s) + K_g(s)}}}}} \right) \quad L(1.5) = 2.09$$

$$L_S \left(\frac{-1.5^2}{t_0} \right) = 2.09$$

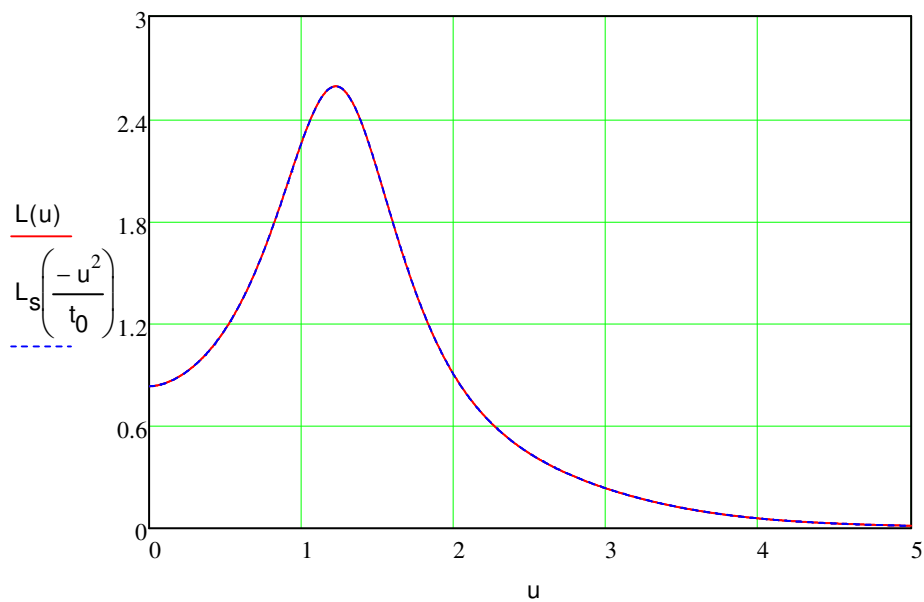

$$u1 := 1.2 \quad L(u1) - L_S \left(\frac{-u1^2}{t_0} \right) = -2.66 \times 10^{-15}$$

Laplace transform for the time derivative of $T_f(t)$

$$Tb'_f(s) := \frac{q_{inj}}{C_p \cdot s + \frac{1}{R_p + \frac{1}{K_p(s) + \frac{1}{\frac{1}{K_t(s)} + \frac{1}{K_b(s) + K_g(s)}}}}}$$

Amplitude and phase

$$A(u, v) := \left| \text{Tb}'_f(u + i \cdot v) \right| \quad B(u, v) := \frac{1}{\pi} \cdot \arg(\text{Tb}'_f(u + i \cdot v))$$

$$A(0.00001, 0) = 2.32$$

$$A(-0.0000001, 0) = 3.7$$

$$A(0, 0.00001) = 2.41$$

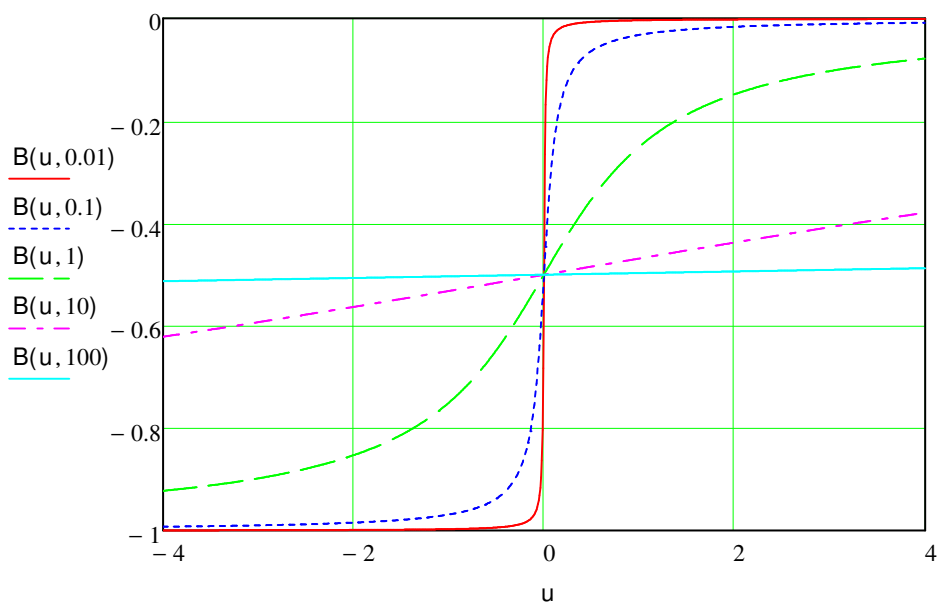
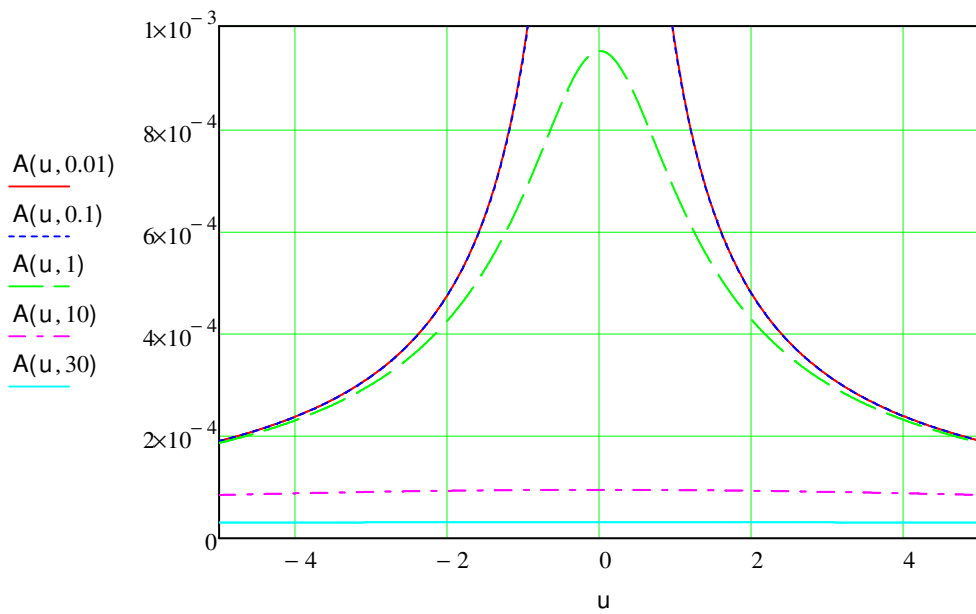

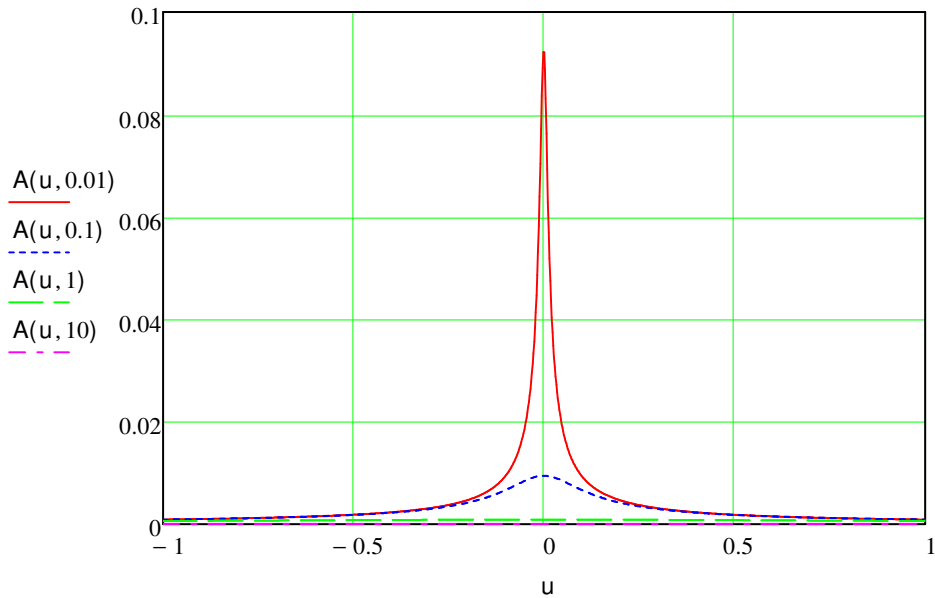

Behavior for small s:

$$\text{Appr}(s) := \frac{q_{inj}}{C_p \cdot s + \frac{1}{R_p + \frac{1}{2 \cdot \pi \cdot \lambda_b} \cdot \ln\left(\frac{r_b}{r_p}\right) + \frac{1}{2 \cdot \pi \cdot \lambda} \cdot \left(\ln\left(\frac{2 \cdot \sqrt{a}}{r_b \cdot \sqrt{s}}\right) - 0.5772\right)}}$$

$$\varepsilon := 10^{-6}$$

$$s_1 := \varepsilon$$

$$Tb'_f(s_1) = 2.98$$

$$\text{Appr}(s_1) - Tb'_f(s_1) = 0$$

$$s_1 := \varepsilon \cdot \frac{1 + i \cdot 1}{\sqrt{2}}$$

$$Tb'_f(s_1) = 2.99 - 0.21i$$

$$\text{Appr}(s_1) - Tb'_f(s_1) = 0 + 8.63i \times 10^{-4}$$

$$s_1 := \varepsilon \cdot i \cdot 1$$

$$Tb'_f(s_1) = 2.99 - 0.43i$$

$$\text{Appr}(s_1) - Tb'_f(s_1) = 6.77 \times 10^{-4} + 0i$$

$$s_1 := \varepsilon \cdot \frac{-1 + i}{\sqrt{2}}$$

$$Tb'_f(s_1) = 3 - 0.64i$$

$$\text{Appr}(s_1) - Tb'_f(s_1) = -2.95 \times 10^{-4} + 0i$$

$$s_1 := \varepsilon \cdot (-1)$$

$$Tb'_f(s_1) = 3.01 - 0.84i$$

$$\text{Appr}(s_1) - Tb'_f(s_1) = -0 + 0i$$

$$\underline{\underline{\varepsilon}} := 10^{-5}$$

$\underline{\underline{s1}} := \varepsilon$	$Tb'_f(s1) = 2.32$	$Appr(s1) - Tb'_f(s1) = 0.01$
$\underline{\underline{s1}} := \varepsilon \cdot \frac{1+i \cdot 1}{\sqrt{2}}$	$Tb'_f(s1) = 2.33 - 0.24i$	$Appr(s1) - Tb'_f(s1) = 0.01 + 0i$
$\underline{\underline{s1}} := \varepsilon \cdot i \cdot 1$	$Tb'_f(s1) = 2.36 - 0.48i$	$Appr(s1) - Tb'_f(s1) = 0 + 0.01i$
$\underline{\underline{s1}} := \varepsilon \cdot \frac{-1+i}{\sqrt{2}}$	$Tb'_f(s1) = 2.4 - 0.7i$	$Appr(s1) - Tb'_f(s1) = 0 + 0.01i$
$\underline{\underline{s1}} := \varepsilon \cdot (-1)$	$Tb'_f(s1) = 2.44 - 0.89i$	$Appr(s1) - Tb'_f(s1) = -0 + 0.01i$

$$\underline{\underline{\varepsilon}} := 10^{-4}$$

$\underline{\underline{s1}} := \varepsilon$	$Tb'_f(s1) = 1.48$	$Appr(s1) - Tb'_f(s1) = 0.02$
$\underline{\underline{s1}} := \varepsilon \cdot \frac{1+i \cdot 1}{\sqrt{2}}$	$Tb'_f(s1) = 1.49 - 0.34i$	$Appr(s1) - Tb'_f(s1) = 0.02 + 4i \times 10^{-4}$
$\underline{\underline{s1}} := \varepsilon \cdot i \cdot 1$	$Tb'_f(s1) = 1.55 - 0.69i$	$Appr(s1) - Tb'_f(s1) = 0.03 + 0i$
$\underline{\underline{s1}} := \varepsilon \cdot \frac{-1+i}{\sqrt{2}}$	$Tb'_f(s1) = 1.7 - 1.05i$	$Appr(s1) - Tb'_f(s1) = 0.04 + 0.02i$
$\underline{\underline{s1}} := \varepsilon \cdot (-1)$	$Tb'_f(s1) = 2.02 - 1.32i$	$Appr(s1) - Tb'_f(s1) = 0.03 + 0.08i$

$$\underline{\underline{\varepsilon}} := 10^{-3}$$

$\underline{\underline{s1}} := \varepsilon$	$Tb'_f(s1) = 0.52$	$Appr(s1) - Tb'_f(s1) = -0$
$\underline{\underline{s1}} := \varepsilon \cdot \frac{1+i \cdot 1}{\sqrt{2}}$	$Tb'_f(s1) = 0.48 - 0.27i$	$Appr(s1) - Tb'_f(s1) = -0 - 0.01i$
$\underline{\underline{s1}} := \varepsilon \cdot i \cdot 1$	$Tb'_f(s1) = 0.34 - 0.55i$	$Appr(s1) - Tb'_f(s1) = -0.02 - 0.02i$
$\underline{\underline{s1}} := \varepsilon \cdot \frac{-1+i}{\sqrt{2}}$	$Tb'_f(s1) = 0 - 0.87i$	$Appr(s1) - Tb'_f(s1) = -0.07 - 0.04i$
$\underline{\underline{s1}} := \varepsilon \cdot (-1)$	$Tb'_f(s1) = -0.86 - 1.07i$	$Appr(s1) - Tb'_f(s1) = -0.35 + 0.05i$

A4.5 Pipe in ground.

Step-response for a pipe in surrounding ground. Constant heat injection rate to the pipe fluid. Basic example.

J.C. Jan. 2011

Input data:

$$q_{inj} := 10 \quad \lambda := 3.0 \quad \rho c := 2500 \cdot 750 \quad r_p := 0.02 \cdot \sqrt{2} \quad a := \frac{\lambda}{\rho c}$$

$$C_p := \pi \cdot r_p^2 \cdot 4.18 \cdot 10^6 \quad d_{pw} := 0.0023 \quad \lambda_p := 0.42 \quad h_p := 725$$

$$R_p := \frac{1}{2 \cdot \pi \cdot \lambda_p} \cdot \ln\left(\frac{r_p}{r_p - d_{pw}}\right) + \frac{1}{2 \cdot r_p \cdot h_p} \quad C_p = 1.05 \times 10^4 \quad R_p = 0.06 \quad a = 1.6 \times 10^{-6}$$

Laplace solution

$$t_p := \frac{r_p^2}{a} \quad R_{bg}(u) := \frac{1}{2 \cdot \pi \cdot \lambda} \cdot \frac{J_0(u) - i \cdot Y_0(u)}{u \cdot (J_1(u) - i \cdot Y_1(u))} \quad t_p = 500$$

$$L(u) := \operatorname{Im}\left(\frac{-q_{inj}}{C_p \cdot \frac{-u^2}{t_p} + \frac{1}{R_p + R_{bg}(u)}}\right) \quad T_f(t) := \frac{2}{\pi} \cdot \int_0^{\infty} \frac{1 - e^{-u^2 \cdot \frac{t}{t_p}}}{u} \cdot L(u) \, du$$

$$T_f(0) = 0 \quad T_f(60) = 0.05 \quad T_f(600) = 0.42 \quad T_f(3600) = 1.14$$

$$T_f(10 \cdot 3600) = 1.89 \quad T_f(100 \cdot 3600) = 2.52 \quad T_f(1000 \cdot 3600) = 3.14$$

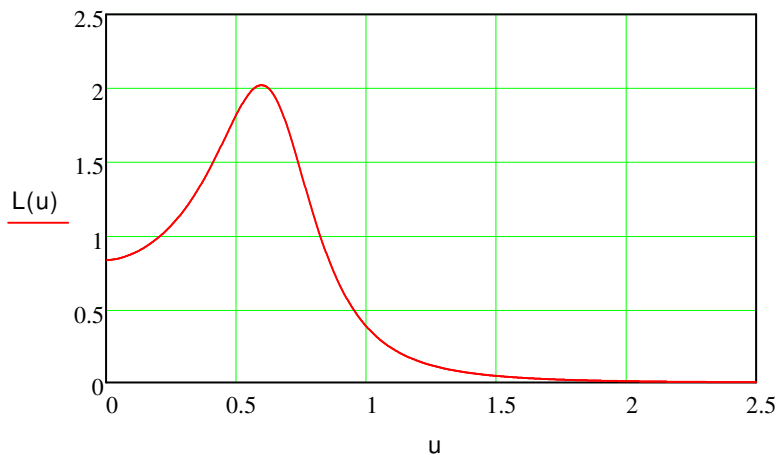

Dimensionless solution

$$\mu := 2 \cdot \pi \cdot \lambda \cdot R_p \quad \sigma_f := \frac{4.18 \cdot 10^6}{2 \cdot \rho c} \quad T_{inj} := \frac{q_{inj}}{2 \cdot \pi \cdot \lambda}$$

$$\mu = 1.07 \quad \sigma_f = 1.11 \quad T_{inj} = 0.53 \quad t_p = 500$$

$$Rb'_g(u) := \frac{J_0(u) - i \cdot Y_0(u)}{u \cdot (J_1(u) - i \cdot Y_1(u))} \quad L'(u, \sigma_f, \mu) := \operatorname{Im} \left[\frac{-1}{\sigma_f \cdot (-u^2) + \frac{1}{\mu + Rb'_g(u)}} \right]$$

$$T_f(t', \sigma_f, \mu) := \frac{2}{\pi} \cdot \int_0^{\infty} \frac{1 - e^{-u^2 \cdot t'}}{u} \cdot L'(u, \sigma_f, \mu) \, du$$

$$T_{inj} \cdot T_f(1, \sigma_f, \mu) = 0.36$$

$$T_f(t_p) = 0.36$$

$$T_{inj} \cdot T_f(1, \sigma_f, \mu) - T_f(t_p) = 0$$

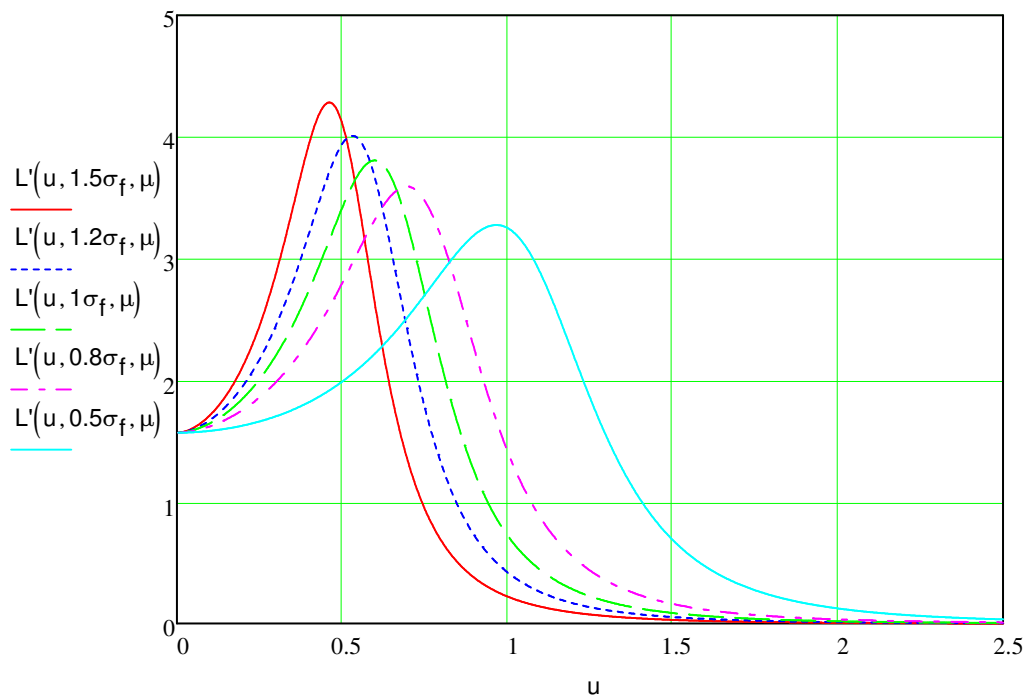

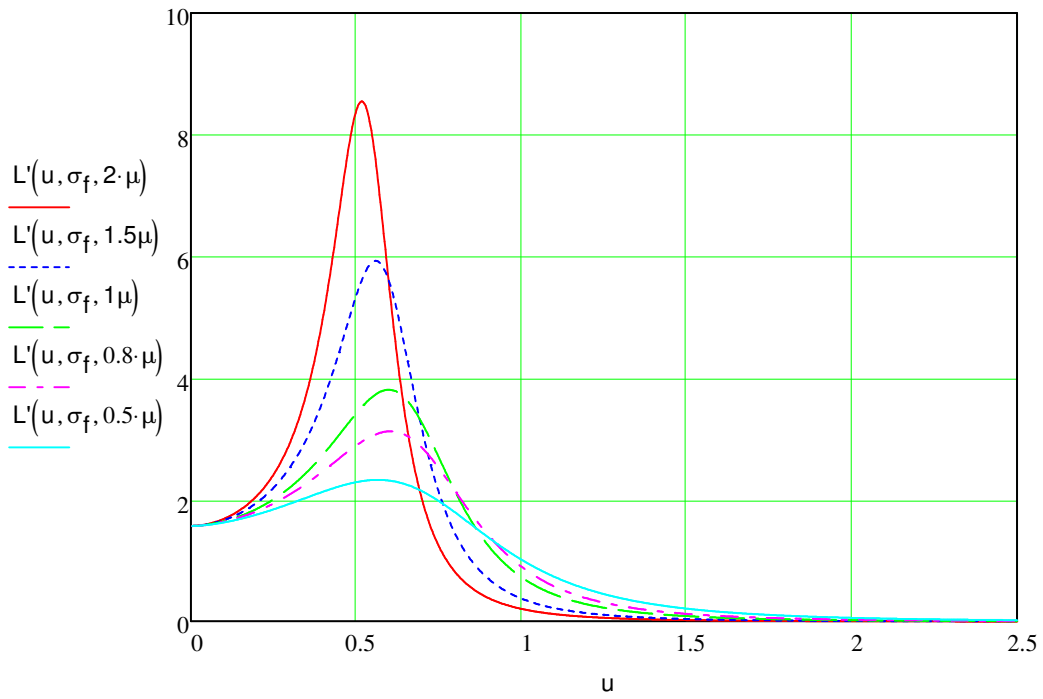

$t_p = 500$

$T_{inj} = 0.53$

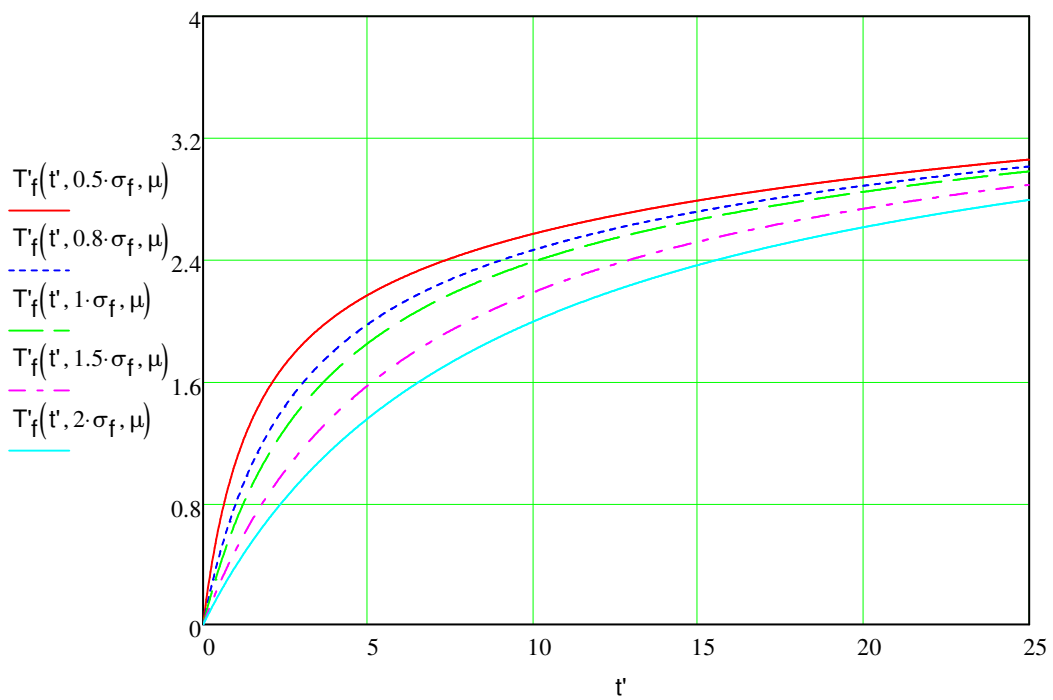

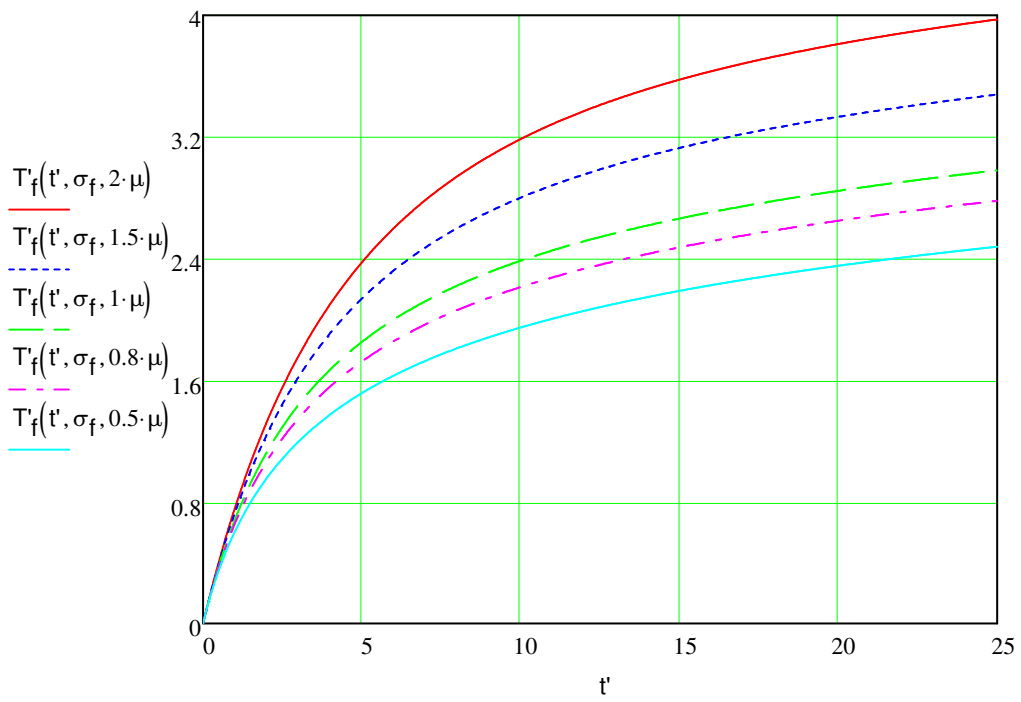
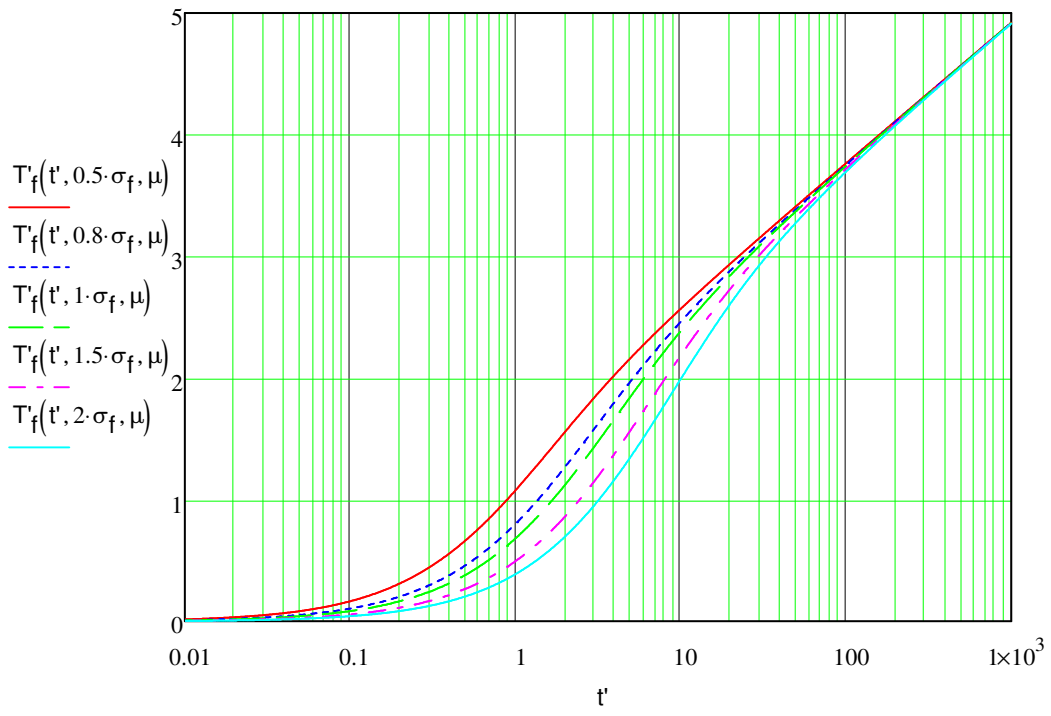

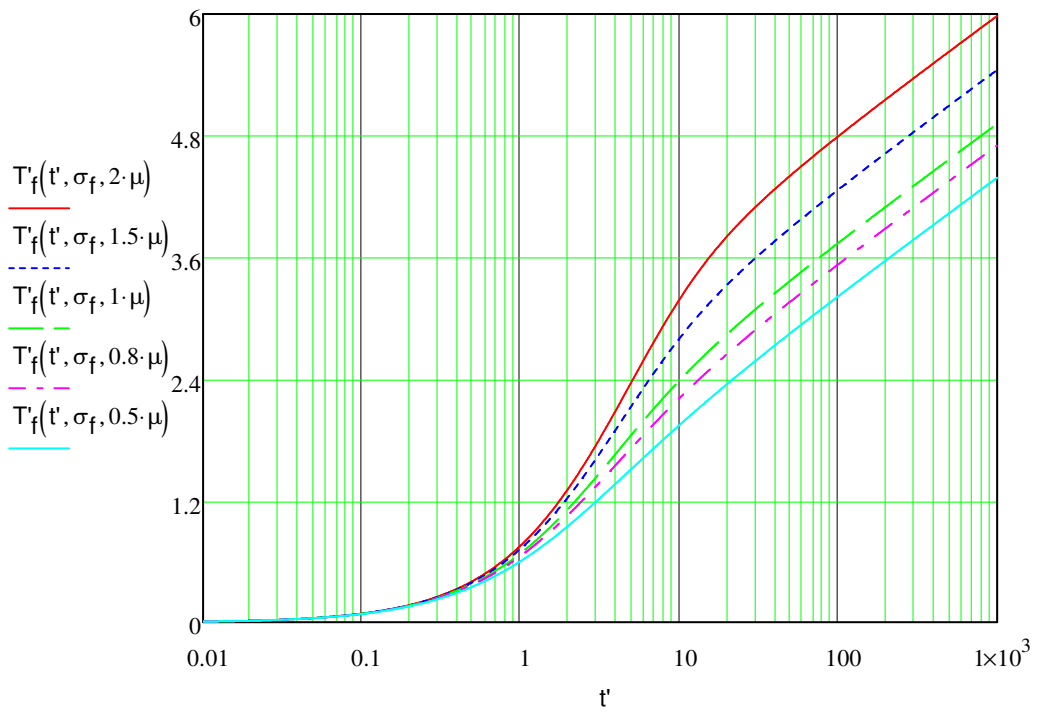

A4.6 Comparison of pipe and borehole solutions

J.C. Jan. 2011

Input data:

$$q_{inj} := 10 \quad \lambda := 3.0 \quad \rho c := 2500 \cdot 750 \quad \lambda_b := \lambda \quad \rho c_b := \rho c$$

Same thermal data for ground and borehole annulus!

$$r_p := 0.02 \cdot \sqrt{2} \quad r_b := 0.055 \quad a_b := \frac{\lambda_b}{\rho c_b} \quad a := \frac{\lambda}{\rho c} \quad C_p := \pi \cdot r_p^2 \cdot 4.18 \cdot 10^6$$

$$d_{pw} := 0.0023 \quad \lambda_p := 0.42 \quad h_p := 725 \quad R_p := \frac{1}{2 \cdot \pi \cdot \lambda_p} \cdot \ln\left(\frac{r_p}{r_p - d_{pw}}\right) + \frac{1}{2 \cdot r_p \cdot h_p}$$

$$t_0 := 3600 \quad C_p = 1.05 \times 10^4 \quad R_p = 0.06 \quad a_b = 1.6 \times 10^{-6} \quad a = 1.6 \times 10^{-6}$$

Thermal resistances:

$$\tau_p := \frac{r_p}{\sqrt{a_b \cdot t_0}} \quad \tau_b := \frac{r_b}{\sqrt{a_b \cdot t_0}} \quad \tau_g := \frac{r_b}{\sqrt{a \cdot t_0}}$$

$$Kb_t(u) := \frac{4 \cdot \lambda_b}{J_0(\tau_p \cdot u) \cdot Y_0(\tau_b \cdot u) - Y_0(\tau_p \cdot u) \cdot J_0(\tau_b \cdot u)} \quad (b = \text{bar})$$

$$Kb_p(u) := 4 \cdot \lambda_b \cdot \frac{0.5 \pi \cdot \tau_p \cdot u \cdot (J_1(\tau_p \cdot u) \cdot Y_0(\tau_b \cdot u) - Y_1(\tau_p \cdot u) \cdot J_0(\tau_b \cdot u)) - 1}{J_0(\tau_p \cdot u) \cdot Y_0(\tau_b \cdot u) - Y_0(\tau_p \cdot u) \cdot J_0(\tau_b \cdot u)}$$

$$Kb_b(u) := 4 \cdot \lambda_b \cdot \frac{0.5 \pi \cdot \tau_b \cdot u \cdot (J_1(\tau_b \cdot u) \cdot Y_0(\tau_p \cdot u) - Y_1(\tau_b \cdot u) \cdot J_0(\tau_p \cdot u)) - 1}{J_0(\tau_p \cdot u) \cdot Y_0(\tau_b \cdot u) - Y_0(\tau_p \cdot u) \cdot J_0(\tau_b \cdot u)}$$

$$Kb_g(u) := 2 \cdot \pi \cdot \lambda \cdot \frac{\tau_g \cdot u \cdot (J_1(\tau_g \cdot u) - i \cdot Y_1(\tau_g \cdot u))}{J_0(\tau_g \cdot u) - i \cdot Y_0(\tau_g \cdot u)}$$

Laplace transform and inversion integral:

$$L(u) := \operatorname{Im} \left(\frac{-q_{inj}}{C_p \cdot \frac{-u^2}{t_0} + \frac{1}{R_p + \frac{1}{Kb_p(u) + \frac{1}{\frac{1}{Kb_t(u)} + \frac{1}{Kb_b(u) + Kb_g(u)}}}}} \right)$$

$$T_f(t) := \frac{2}{\pi} \cdot \int_0^{\infty} \frac{1 - e^{-u^2 \cdot \frac{t}{t_0}}}{u} \cdot L(u) \, du \quad T_f(0) = 0 \quad T_f(60) = 0.05 \quad T_f(600) = 0.42$$

$$T_f(3600) = 1.14 \quad T_f(10 \cdot 3600) = 1.89 \quad T_f(100 \cdot 3600) = 2.52 \quad T_f(1000 \cdot 3600) = 3.14$$

Solution for pipe in the ground:

$$t_p := \frac{r_p^2}{a} \quad R_{bp_g}(u) := \frac{1}{2 \cdot \pi \cdot \lambda} \cdot \frac{J_0(u) - i \cdot Y_0(u)}{u \cdot (J_1(u) - i \cdot Y_1(u))}$$

$$L_p(u) := \operatorname{Im} \left(\frac{-q_{inj}}{C_p \cdot \frac{-u^2}{t_p} + \frac{1}{R_p + R_{bp_g}(u)}} \right) \quad T_{p_f}(t) := \frac{2}{\pi} \cdot \int_0^{\infty} \frac{1 - e^{-u^2 \cdot \frac{t}{t_p}}}{u} \cdot L_p(u) \, du$$

$$T_{p_f}(0) = 0 \quad T_{p_f}(60) = 0.05 \quad T_{p_f}(600) = 0.42$$

$$T_{p_f}(3600) = 1.14 \quad T_{p_f}(10 \cdot 3600) = 1.89 \quad T_{p_f}(100 \cdot 3600) = 2.52 \quad T_{p_f}(1000 \cdot 3600) = 3.14$$

$$T_f(3600) - T_{p_f}(3600) = 1.4 \times 10^{-12} \quad T_f(10 \cdot 3600) - T_{p_f}(10 \cdot 3600) = 6.39 \times 10^{-13}$$

Note: $u^2 \cdot \frac{t}{t_0} = \left(u \cdot \sqrt{\frac{t_p}{t_0}} \right)^2 \cdot \frac{t}{t_p}$ ■

$L(1.5) - Lp\left(1.5 \cdot \sqrt{\frac{t_p}{t_0}}\right) = 0$

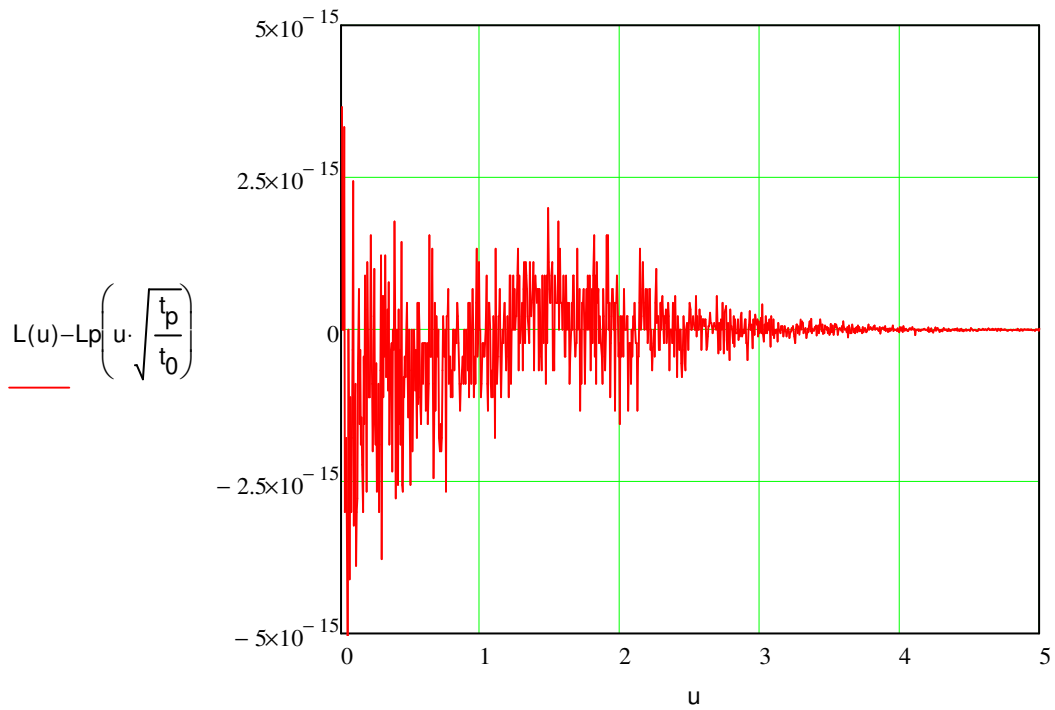
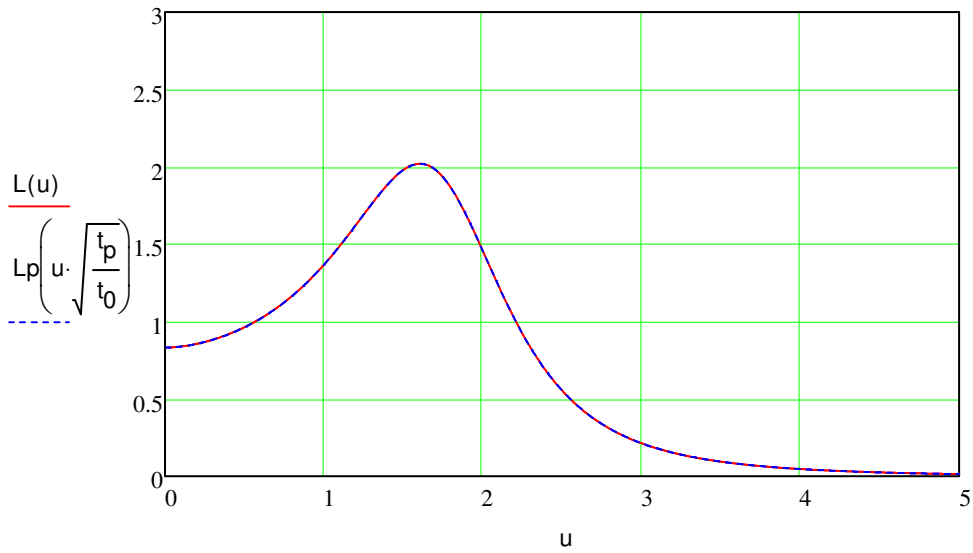

A4.7 Bessel functions

To Report on Mathematical Background

Ordinary Bessel functions

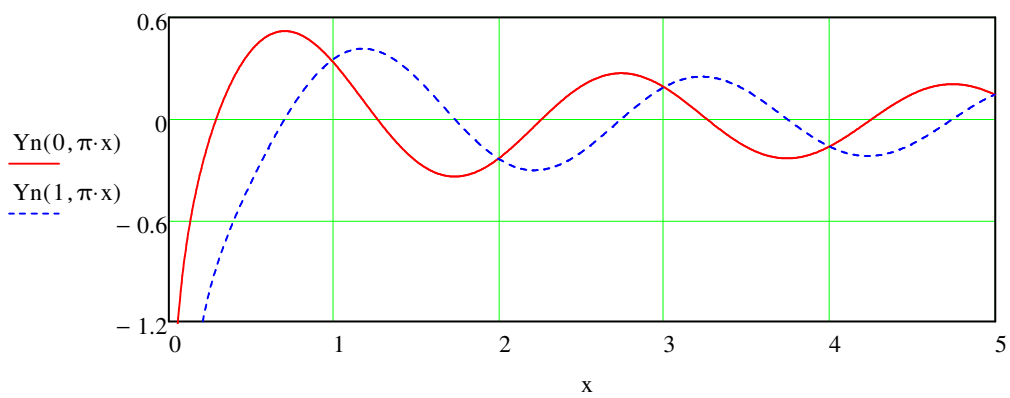
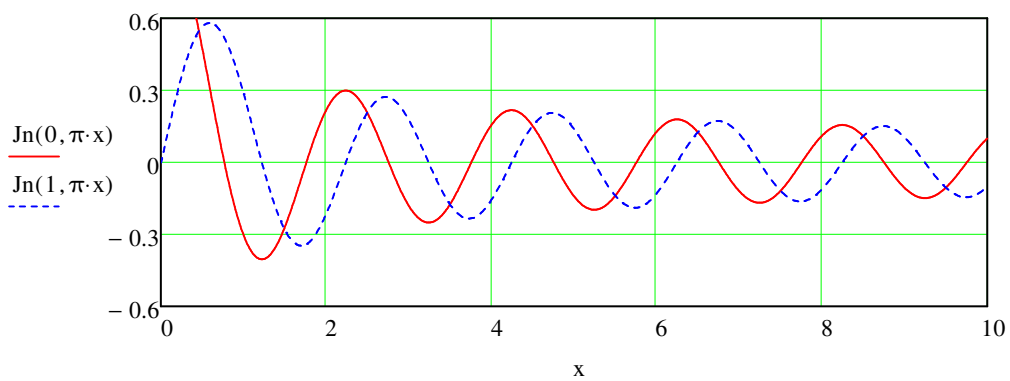
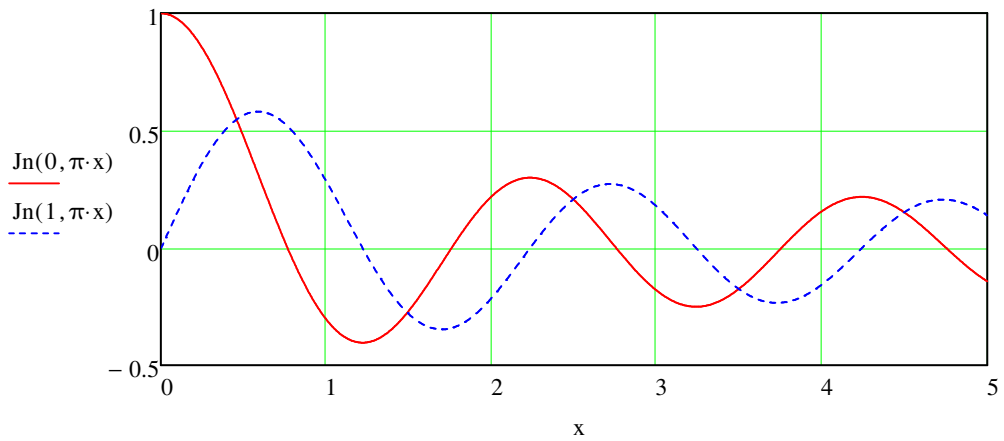

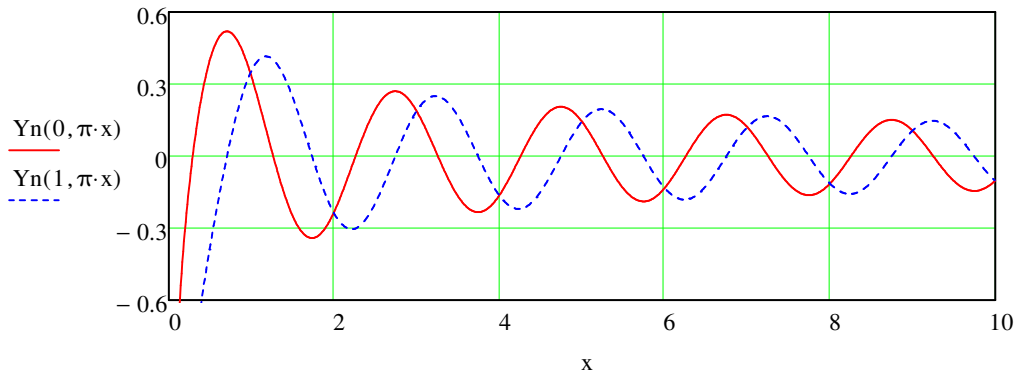

Modified Bessel functions

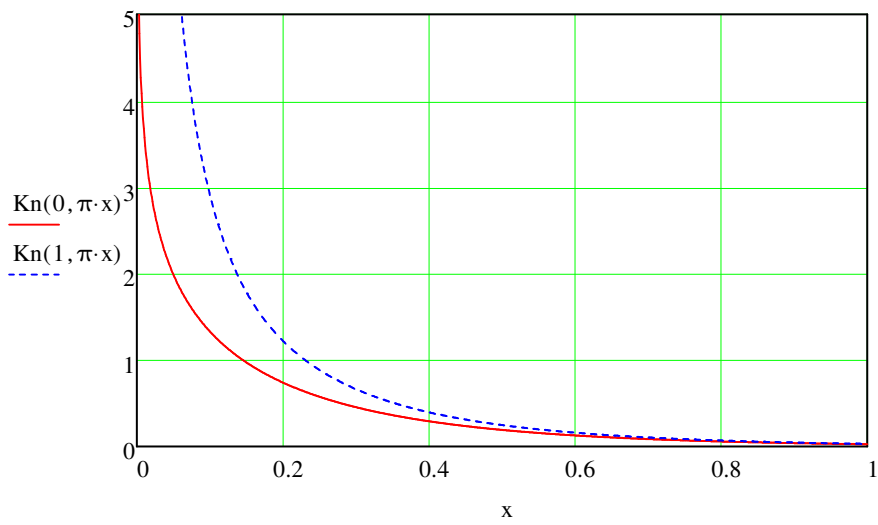
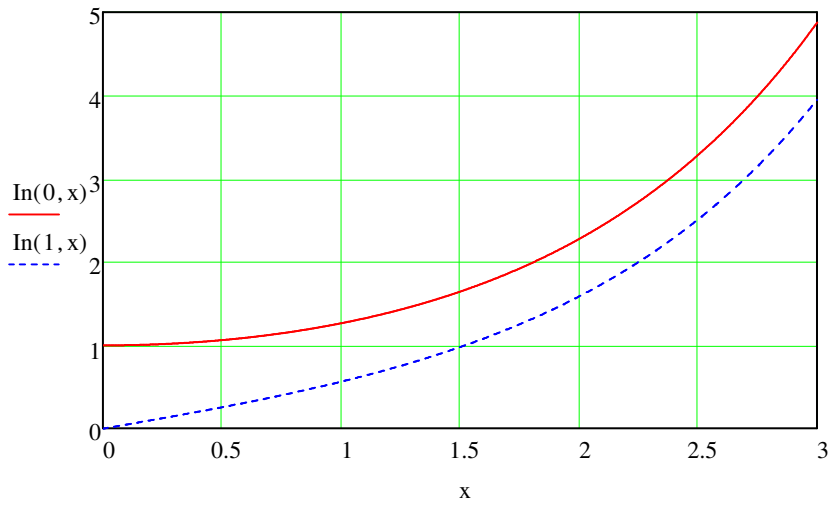

Control of Bessel's differential equation

Eq. (11.1):
$$\text{BesselJ}(n, x) := \frac{d^2}{dx^2} J_n(n, x) + \frac{1}{x} \cdot \frac{d}{dx} J_n(n, x) + \left(1 - \frac{n^2}{x^2}\right) \cdot J_n(n, x)$$

$$\text{BesselY}(n, x) := \frac{d^2}{dx^2} Y_n(n, x) + \frac{1}{x} \cdot \frac{d}{dx} Y_n(n, x) + \left(1 - \frac{n^2}{x^2}\right) \cdot Y_n(n, x)$$

Eq. (11.2):
$$\text{BesselI}(n, x) := \frac{d^2}{dx^2} I_n(n, x) + \frac{1}{x} \cdot \frac{d}{dx} I_n(n, x) - \left(1 + \frac{n^2}{x^2}\right) \cdot I_n(n, x)$$

$$\text{BesselK}(n, x) := \frac{d^2}{dx^2} K_n(n, x) + \frac{1}{x} \cdot \frac{d}{dx} K_n(n, x) - \left(1 + \frac{n^2}{x^2}\right) \cdot K_n(n, x)$$

$$n1 := 0 \quad x1 := 1.3 \quad \text{BesselJ}(n1, x1) = 1.35 \times 10^{-13} \quad \text{BesselY}(n1, x1) = -6.662 \times 10^{-13}$$

$$\text{BesselJ}(n1, x1) = 1.199 \times 10^{-14} \quad \text{BesselY}(n1, x1) = -8.842 \times 10^{-11}$$

$$n1 := 0 \quad x1 := 1.1 \quad \text{BesselI}(n1, x1) = 2.034 \times 10^{-13} \quad \text{BesselK}(n1, x1) = 1.052 \times 10^{-12}$$

$$n1 := 1 \quad x1 := 0.6 \quad \text{BesselI}(n1, x1) = 1.25 \times 10^{-13} \quad \text{BesselK}(n1, x1) = 5.154 \times 10^{-12}$$

Complex arguments

$$z1 := 1 + 2i \quad J_n(0, z1) = 1.586 - 1.392i \quad Y_n(1, z1) = -1.089 + 1.315i$$

$$I_n(0, z1) = 0.188 + 0.646i \quad K_n(1, z1) = -0.3 - 0.151i$$

Wronskian relation **Eq. (11.3):**
$$I_1(z) \cdot K_0(z) + K_1(z) \cdot I_0(z) = \frac{1}{z}$$

$$I_n(1, z1) \cdot K_n(0, z1) + K_n(1, z1) \cdot I_n(0, z1) - \frac{1}{z1} = 0$$

Derivatives **Eq. (11.4):** $K'_0(z) = -K_1(z)$ $I'_0(z) = I_1(z)$

$$K_n(1, z1) = -0.3 - 0.151i \qquad I_n(1, z1) = -0.08 + 0.791i$$

$$\Delta z1 := 10^{-6} \cdot (1 + 2i) \qquad \Delta z2 := 10^{-6} \cdot (-1 + 0.5i)$$

$$\frac{K_n(0, z1 + \Delta z1) - K_n(0, z1)}{\Delta z1} + K_n(1, z1) = -9.515 \times 10^{-8} - 4.06i \times 10^{-7}$$

$$\frac{K_n(0, z1 + \Delta z2) - K_n(0, z1)}{\Delta z2} + K_n(1, z1) = 2.031 \times 10^{-7} - 4.753i \times 10^{-8}$$

$$\frac{I_n(0, z1 + \Delta z1) - I_n(0, z1)}{\Delta z1} - I_n(1, z1) = -5.124 \times 10^{-7} + 1.156i \times 10^{-7}$$

Relations for Bessel functions:

Eq. (11.5): $K_0(iu) = -\frac{i\pi}{2} \cdot (J_0(u) - iY_0(u))$ $K_1(iu) = -\frac{\pi}{2} \cdot (J_1(u) - iY_1(u))$

Eq. (11.6): $I_0(iu) = J_0(u)$ $I_1(iu) = iJ_1(u)$

$u1 := 0.4$ $K_n(0, i \cdot u1) + \frac{i \cdot \pi}{2} \cdot (J_n(u1) - i \cdot Y_n(0, u1)) = 0$

$$K_n(1, i \cdot u1) + \frac{\pi}{2} \cdot (J_n(1, u1) - i \cdot Y_n(1, u1)) = 0$$

$$I_n(0, i \cdot u1) - J_n(0, u1) = 0 \qquad I_n(1, i \cdot u1) - i \cdot J_n(1, u1) = 0$$

Eq. (11.7): $\frac{i \cdot u \cdot K_1(i \cdot u)}{K_0(i \cdot u)} = \frac{u \cdot (J_1(u) - i \cdot Y_1(u))}{J_0(u) - i \cdot Y_0(u)}$ $0 < u < \infty$

$u1 := 2$ $\frac{i \cdot u1 \cdot K_n(1, i \cdot u1)}{K_n(0, i \cdot u1)} - \frac{u1 \cdot (J_n(1, u1) - i \cdot Y_n(1, u1))}{J_0(u1) - i \cdot Y_0(u1)} = 0$

$u1 := 0.03$ $\frac{i \cdot u1 \cdot K_n(1, i \cdot u1)}{K_n(0, i \cdot u1)} - \frac{u1 \cdot (J_n(1, u1) - i \cdot Y_n(1, u1))}{J_0(u1) - i \cdot Y_0(u1)} = 0$

$$\underline{u1} := 0.001 \quad \frac{i \cdot u1 \operatorname{Kn}(1, i \cdot u1)}{\operatorname{Kn}(0, i \cdot u1)} - \frac{u1 \cdot (\operatorname{Jn}(1, u1) - i \cdot \operatorname{Yn}(1, u1))}{\operatorname{J0}(u1) - i \cdot \operatorname{Y0}(u1)} = 0$$

$$\underline{u1} := 200 \quad \frac{i \cdot u1 \operatorname{Kn}(1, i \cdot u1)}{\operatorname{Kn}(0, i \cdot u1)} - \frac{u1 \cdot (\operatorname{Jn}(1, u1) - i \cdot \operatorname{Yn}(1, u1))}{\operatorname{J0}(u1) - i \cdot \operatorname{Y0}(u1)} = -1.083 \times 10^{-12} + 5.684i \times 10^{-14}$$

Eqs. (6.26) and (6.28):

$$\operatorname{K0}(i \cdot u \cdot \tau_p) \cdot \operatorname{I0}(i \cdot u \cdot \tau_b) - \operatorname{I0}(i \cdot u \cdot \tau_p) \cdot \operatorname{K0}(i \cdot u \cdot \tau_b) = \frac{\pi}{2} \cdot (\operatorname{J0}(\tau_p \cdot u) \cdot \operatorname{Y0}(\tau_b \cdot u) - \operatorname{Y0}(\tau_p \cdot u) \cdot \operatorname{J0}(\tau_b \cdot u)) \blacksquare$$

Eqs. (6.27) and (6.29):

$$\operatorname{I1}(i \cdot u \cdot \tau_p) \cdot \operatorname{K0}(i \cdot u \cdot \tau_b) + \operatorname{K1}(i \cdot u \cdot \tau_p) \cdot \operatorname{I0}(i \cdot u \cdot \tau_b) = \frac{\pi}{i \cdot 2} \cdot (\operatorname{J1}(\tau_p \cdot u) \cdot \operatorname{Y0}(\tau_b \cdot u) - \operatorname{Y1}(\tau_p \cdot u) \cdot \operatorname{J0}(\tau_b \cdot u)) \blacksquare$$

$$\tau_p := 0.7 \quad \tau_b := 1.26 \quad \underline{u1} := 0.3$$

$$\operatorname{Kn}(0, i \cdot u1 \cdot \tau_p) \cdot \operatorname{In}(0, i \cdot u1 \cdot \tau_b) - \operatorname{In}(0, i \cdot u1 \cdot \tau_p) \cdot \operatorname{Kn}(0, i \cdot u1 \cdot \tau_b) = 0.585$$

$$\frac{\pi}{2} \cdot (\operatorname{Jn}(0, \tau_p u1) \cdot \operatorname{Yn}(0, \tau_b u1) - \operatorname{Yn}(0, \tau_p u1) \cdot \operatorname{Jn}(0, \tau_b u1)) = 0.585$$

$$\operatorname{In}(1, i \cdot u1 \cdot \tau_p) \cdot \operatorname{Kn}(0, i \cdot u1 \cdot \tau_b) + \operatorname{Kn}(1, i \cdot u1 \cdot \tau_p) \cdot \operatorname{In}(0, i \cdot u1 \cdot \tau_b) = -4.706i$$

$$\frac{\pi}{i \cdot 2} \cdot (\operatorname{Jn}(1, \tau_p u1) \cdot \operatorname{Yn}(0, \tau_b u1) - \operatorname{Yn}(1, \tau_p u1) \cdot \operatorname{Jn}(0, \tau_b u1)) = -4.706i$$